



West Virginia Parkways Authority

REQUEST FOR QUOTATIONS

The West Virginia Parkways Authority will receive sealed proposals for the following:

FABRICATED ALUMINUM TRAFFIC CONTROL BED

Proposals will be received at the office of the WV Parkways Authority, Administration Building, 3310 Piedmont Rd., Charleston, WV until **2PM on Tuesday, August 13th, 2024.** If proposals are mailed via the U. S. Postal Service regular mail, they must be addressed to the WV Parkways Authority, P. O. Box 1469, Charleston, WV 25325. This mail is picked up by the Authority once a day between 7:00 and 8:00 a.m. However, Drop-Off, Express Mail One Day Service, Federal Express, United Parcel Service (UPS), etc. must be delivered / sent to the West Virginia Parkways Authority, 3310 Piedmont Rd., Charleston, WV 25306. Faxed or emailed bids will not be accepted.

It shall be the bidders' responsibility to determine their method of transmittal such that their bids will arrive in the Authority's office prior to the scheduled bid opening. The Authority cannot waive or excuse late receipt of a proposal which is delayed and late for any reason. Late submissions will not be accepted and will remain unopened. Any proposal received after the proposal opening date and time will be immediately disqualified in accordance with applicable law and administrative rules and regulations applicable to the Authority. Changes to the Request for Quotation may be posted at any time to our website www.wvturnpike.com under the Purchasing tab. It is the Vendors responsibility to check the website. Any addendum issued must be signed and submitted with your RFQ.

All proposals **must** be enclosed in a sealed envelope. The outside of the envelope must include the name and address of the proposer and clearly marked as follows:

Attn: Purchasing Department

RFQ: Fabricated Aluminum Traffic Control Bed (1)

Bid Opening Date: 8/13/24

Specifications are available at www.wvturnpike.com

The West Virginia Parkways Authority reserves the right to reject any and/or all proposals. Prospective vendors are responsible for all toll charges incurred while providing goods or services to the West Virginia Parkways Authority.

The WVPA is an Equal Opportunity Employer.

SECTION 1.0 INSTRUCTIONS TO VENDORS SUBMITTING BIDS: The attached documents contain a solicitation for proposals. Please read these instructions and all documents in their entirety. These instructions provide critical information about requirements that if overlooked could lead to disqualification of a Vendor's proposal. All bids must be submitted in accordance with the provisions contained in these instructions and the Solicitation. Failure to do so may result in disqualification of such Vendor's proposal.

1.1 Questions

All questions must be submitted in writing. Questions regarding this RFQ should be directed to Margaret Vickers, Director of Purchasing, Phone 304 926-1900, fax 304 926-1909 or email: mvickers@wvturnpike.com. Deadline to submit written questions: Thursday, August 8th, 2024 by 12 noon EST. Non-written discussions, conversations, or questions and answers regarding this solicitation are preliminary in nature and are nonbinding. Submitted emails should have the proposal solicitation name in the subject line. Only information issued in writing and added to the Solicitation by an official written addendum is binding. Bid Submission page, Bid Pricing Page, Purchasing Affidavit and 2nd Addendum to Master Service Subscription Agreement must be submitted with the Vendors RFQ bid proposal.

1.2 Registration

Prior to contract award, the apparent successful Vendor must be properly registered with the West Virginia Purchasing Division www.wvoasis.gov, WV Secretary of State, WV State Tax Department, as applicable, and any other entities as necessary. Each of these entities has different fees that may be applicable to their respective registration requirements.

1.3 Purchasing Affidavit

Vendors are required to sign, notarize and submit the Purchasing Affidavit stating that neither the Vendor nor related parties owe a debt to the State in excess of \$1,000.00. **The affidavit must be submitted with the Vendor's proposal.** A copy of the Purchasing Affidavit is included herewith.

1.4 Traditional Vendor Preference: Vendors that meet certain requirements are entitled to a price preference when bidding on 1) motor vehicles and 2) construction and maintenance equipment and machinery used in highway and other infrastructure projects. Vendors must request the preference in writing at the time of bid submission and provide (at the time of bid submission) all documentation necessary to prove its entitlement to the preference requested to be eligible. This preference is applied by increasing the bids of other vendors in comparison with the preference recipient.

1.5 Reciprocal Preference: The state of West Virginia applies a reciprocal preference to all solicitations for commodities and printing in accordance with W.Va. Code § 5A-3-37(b). In effect, non-resident vendors receiving a preference in their home states will see that same preference granted to West Virginia resident vendors bidding against them in West Virginia. In order to receive the reciprocal preference, vendors must identify themselves as a West Virginia vendor, provide (at the time of bid submission) all documentation required by W. Va. CSR § 148-1-6.4.d.1. to prove its status as a resident of West Virginia, and request in writing (at the time of bid submission) that reciprocal preference be applied. The required documentation must include, but is not limited to:

- A. A Certificate of Good Standing from the West Virginia Tax Division;

- B. Documentation filed with the Secretary of State showing the state of incorporation, the address of all officers, the corporate headquarters, the address of the principal place of business, and other pertinent information. Entities not required to file with the Secretary of State may provide an affidavit confirming that the headquarters or principal place of business is in West Virginia, along with a copy of a utility bill in the name of the business entity;
- C. A copy of the most recent personal property tax ticket showing taxes have been paid; and
- D. D. An affidavit confirming that the business entity has paid all applicable business taxes imposed by Chapter 11 of the West Virginia Code.

1.6 SWAM Preference: A non-resident vendor certified as a small, women owned, or minority-owned (SWAM) business, pursuant to W. Va. Code § 5A-359, shall be provided the same preference made available to any resident vendor. The SWAM rules found in W. Va. § 148 C.S.R. 22-9 further explain that a non-resident SWAM business will receive the highest preference made available to a resident vendor in the solicitation for which the SWAM business has submitted a bid. In order to obtain this preference, however, a non-resident SWAM business must identify itself as such in writing with the bid and must be properly certified under the rules governing certification pursuant in W. Va. § 148 C.S.R. 22-1 et seq.

**WEST VIRGINIA PARKWAYS AUTHORITY - MAINTENANCE DIVISION
PROCUREMENT SPECIFICATIONS**

FABRICATED ALUMINUM TRAFFIC CONTROL TRUCK BED

1.0 PURPOSE

The West Virginia Parkways Authority, hereafter “Authority”, is accepting quotations to provide aluminum traffic control truck bed for our Chevrolet one (1) ton cab & chassis, (hereinafter referred to as the “unit”) to be purchased by the Authority; to define the provisions to be contained in proposals for the sale of said unit to the Authority; establish a schedule for delivery; and establish criteria for gauging the compliance of the vendor to these specifications.

The authority anticipates purchasing approximately one (1) unit total. Quantity listed above are estimates only. It is understood and agreed that the contract shall cover quantity actually ordered for delivery during the terms of the contract, whether more or less than the quantity shown.

2.0 QUOTATION PROCEDURES

- 2.1 The current purchasing procedures regarding vendors as established by the Authority shall apply.
- 2.2 Vendors are to submit additional literature and information pertinent to their proposal as may be available.
- 2.3 Vendors may submit more than one proposal if different units are to be offered.

3.0 CONDITION OF UNITS UPON DELIVERY

- 3.1 The unit shall arrive completely assembled with no factory defects.
- 3.2 Upon delivery, the Authority will perform a complete inspection of the unit to assure that it meets the Authority’s specifications or accepted alternatives. Final processing for payment may not be initiated until the unit is certified to meet specifications.

4.0 AWARD CRITERIA

- 4.1 It is the Authority’s intent to open this procurement to a wide audience of vendors. The specifications outlined herein are general in nature describing a unit that the Authority feels best meets its needs. However, the Authority will consider any reasonable alternates to the specifications if the vendor can demonstrate that the proposed alternate is comparable in performance, quality and functionality.
- 4.2 If the vendor wishes to point out certain beneficial features of his proposed unit, he may do so in a separate document included in his quotation submittal package. In evaluating the quotations, the Authority will consider any special

or unique features not included in the technical specifications. The Authority will award the vendor that provides the best overall value to the Authority whether or not the vendor has the lowest quotation.

- 4.3 The Authority reserves the right to reject any or all proposals or to waive any non-consequential irregularities or informalities in proposals received. The Authority reserves the right to accept the proposal that will, in the Authority's judgement, best serve the interest of the Authority regardless of whether such proposal is the lowest cost submitted.

5.0 GENERAL SPECIFICATIONS

- One (1) fabricated aluminum traffic control truck bed as per attached drawings.
- Installation required. We will deliver the truck for installation.
- If the unit is picked up, vendor must load unit on the Authority's truck.

Thursday, July 13, 2023

Fla31875_WVPA_07-11-21_Formerly_459707A_VA31875_Misc_Proj.ctb and Request\MTB-1-23\Shanna92-Dier & Ben Framing.dwg

Fiscal Year	County	Sheet No.	Total Sheets
2023		2	5

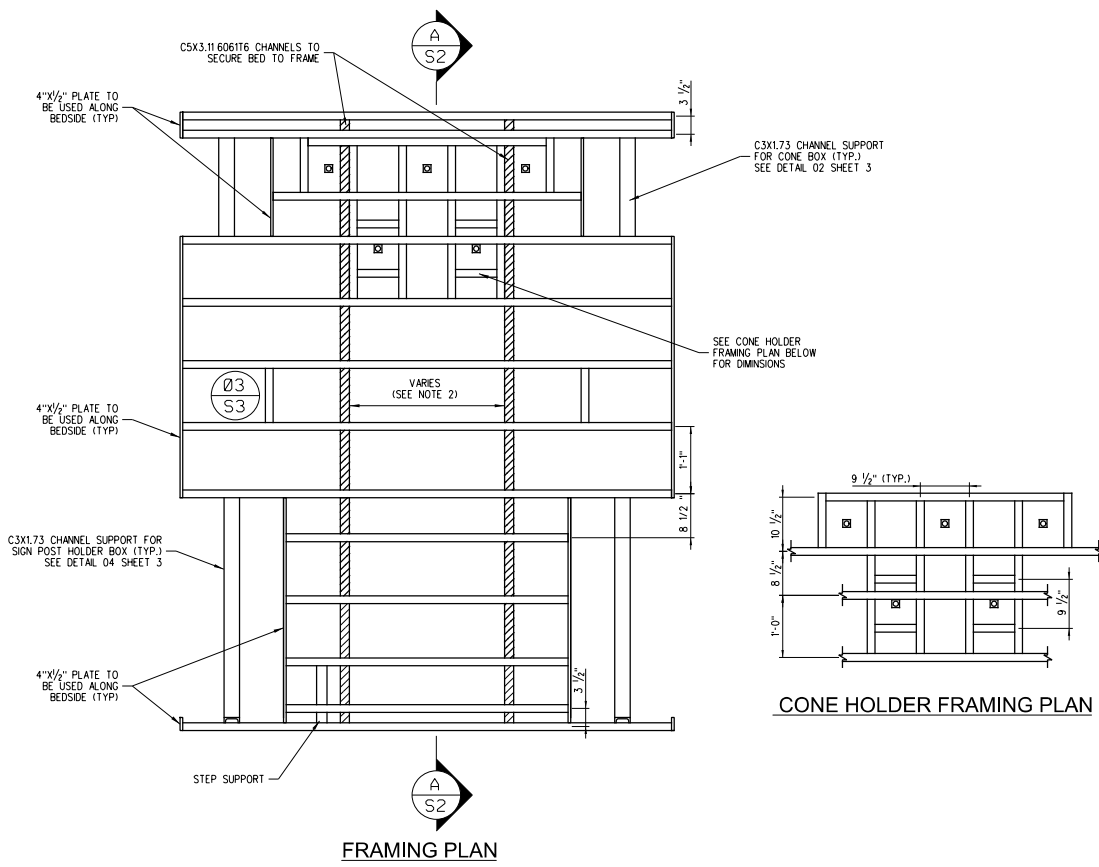

FRAMING PLAN

CONE HOLDER FRAMING PLAN

- NOTES:
- CHANNELS ON BED FRAMING ARE C3X1.73'S ON 12" CENTERS UNLESS SHOWN OTHERWISE.
 - TRUCK FRAME WIDTHS MAY VARY. C5X3.11 CHANNEL TO BE USED TO ATTACH BED TO TRUCK FRAME. CONTACT ROBERT PATTON, FLEET MANAGER AT WVPA FOR DIMENSIONS. PHONE: (304)-255-6928. EMAIL: RPATTON@WVTURNPIKE.COM OR DONNIE PRICE PHONE: (304) 920-8507 EMAIL: WELDINGSHOP@WVTURNPIKE.COM
 - MUD FLAP HOLDER TO BE FIT AROUND SIGN POST HOLDER SUPPORT CHANNEL ACCORDINGLY.
 - CONNECT ALL C3X1.73 CHANNELS TO C5X3.11 CHANNELS WITH A 4" TRIANGULAR GUSSET PLATE 3/16" THICK.
 - C3X1.73 CHANNEL CROSS BRACING FOR 1" CONE HOLDER PLATE STABILIZATION TO BE TIED INTO MAIN SUPPORT CHANNELS.
 - DOUBLE BRACING WITH 3 1/2" SPACING OF CHANNELS AT EACH END OF BED.
 - ALL SQUARE TUBE TO BE 6063T52 WITH 0.250 WALL THICKNESS, UNLESS NOTED.
 - ALL STRUCTURAL TO BE 6061T6 UNLESS NOTED.
 - CHECKER FLOOR PLATE TO BE 6061T6.
 - ALL PIPE TO BE 6061T6 SCHEDULE 40 UNLESS NOTED.

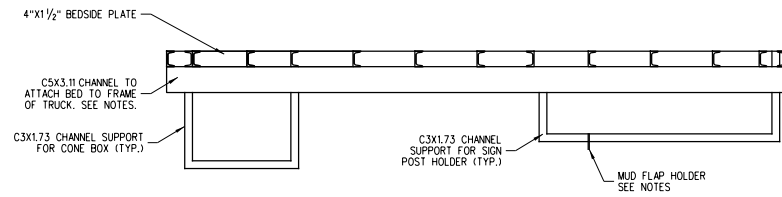

ELEVATION VIEW

- NOTES:
- MUD FLAP HOLDER TO BE FIT AROUND CHANNEL ACCORDINGLY.
 - CHANNELS ARE C3X1.73'S UNLESS OTHERWISE NOTED.
 - ONLY MAIN SUPPORT CHANNELS ARE SHOWN. CONE HOLDER CHANNELS NOT SHOWN FOR CLARITY. SEE CONE HOLDER FRAMING PLAN ABOVE FOR DIMENSIONS.

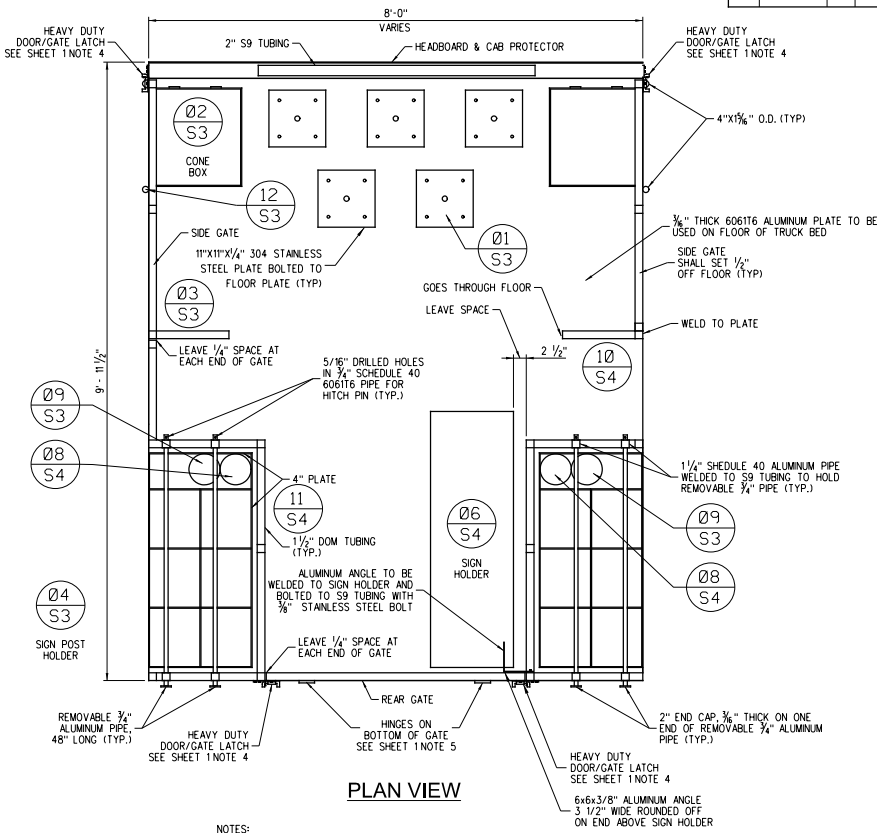

PLAN VIEW

- NOTES:
- 3/8" THICK 6061T6 ALUMINUM CHECKER PLATE TO BE FLUSH WITH 4" x 1/2" PLATE USED ALONG BEDSIDE.
 - 3/8" STAINLESS STEEL BOLTS TO BE USED TO SECURE S9 TUBING TO BED OF TRUCK. SEE DETAIL 04 ON SHEET 3 FOR LOCATIONS.
 - 3/8" STAINLESS STEEL BOLTS TO BE USED TO SECURE THE CONE HOLDER STEEL PLATES TO THE FLOOR.

SCALE: 0 1 R

REVISION NUMBER	SHEET NUMBER	REVISION	DATE	BY

HNTB HNTB CORPORATION
ENGINEERS ARCHITECTS PLANNERS

WEST VIRGINIA TURNPIKE
MOT TRUCK BED

PLAN VIEW

Thursday, July 13, 2023

Thursday, July 13, 2023

FL318187.dwg, WPA, 07-11-23, Format: IFC, Project: Mtn. Pro. and Request: MTR-1-23, Sheets: 03, Detail: Detail

Thursday, July 13, 2023
Project: Mtn. Pro. and Request: MTR-1-23, Sheets: 03, Detail: Detail

01 CONE HOLDER DETAIL

NOT TO SCALE

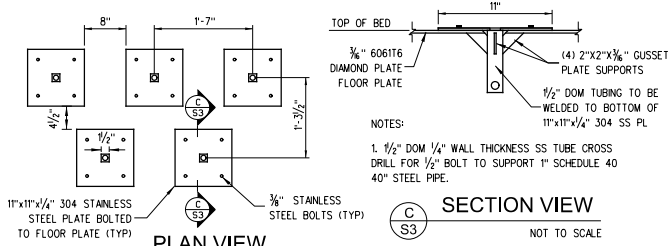

NOTES:
1. 1/2" DOM 1/4" WALL THICKNESS SS TUBE CROSS DRILL FOR 1/2" BOLT TO SUPPORT 1" SCHEDULE 40 40" STEEL PIPE.
2. 3/8" 60616 DIAMOND PLATE - FLOOR PLATE
3. (4) 2"x2"x3/8" GUSSET PLATE SUPPORTS
4. 1/2" DOM TUBING TO BE WELDED TO BOTTOM OF 11"x11"x1/4" 304 SS PL

PLAN VIEW

SECTION VIEW

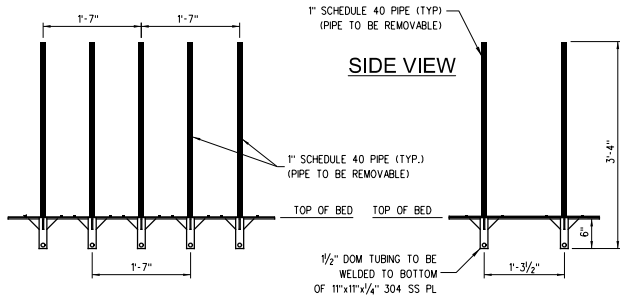

SIDE VIEW

FRONT VIEW

- NOTES:
1. TO HOLD 1" SCHEDULE 40 PIPE, 1/2" DOM TUBING TO BE WELDED TO 11"x11"x1/4" 304 SS PL AND BOLTED TO FLOOR IN 4 PLACES TO ATTACH TO C3 IN FOUR PLACES. PIPE TO FIT LOOSELY IN DOM TUBING.
 2. 1" SCHEDULE 40 STEEL PIPE, 40" LENGTH, WILL REST IN DOM TUBING AND BE REMOVABLE.
 3. 3/8" 60616 DIAMOND PLATE TO BE USED TO SUPPORT CONE HOLDERS. PLATES TO BE BOLTED TO C3x1.73 CHANNEL SUPPORTS ON BED FRAME.
 4. CENTER OF BACK ROW OF 40" SCHEDULE 40 PIPES TO BE 7 3/4" FROM FACE OF HEADBOARD.

02 CONE BOX DETAIL

NOT TO SCALE

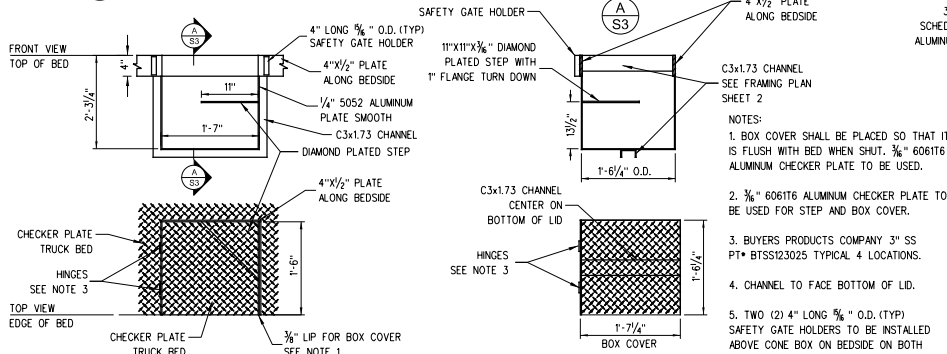

- NOTES:
1. BOX COVER SHALL BE PLACED SO THAT IT IS FLUSH WITH BED WHEN SHUT. 3/8" 60616 ALUMINUM CHECKER PLATE TO BE USED.
 2. 3/8" 60616 ALUMINUM CHECKER PLATE TO BE USED FOR STEP AND BOX COVER.
 3. BUYERS PRODUCTS COMPANY 3" SS P1* BTSS123025 TYPICAL 4 LOCATIONS.
 4. CHANNEL TO FACE BOTTOM OF LID.
 5. TWO (2) 4" LONG 3/4" O.D. (TYP) SAFETY GATE HOLDERS TO BE INSTALLED ABOVE CONE BOX ON BEDSIDE ON BOTH SIDES OF TRUCK BED.

03 GATE SUPPORT DETAIL

AS NOTED

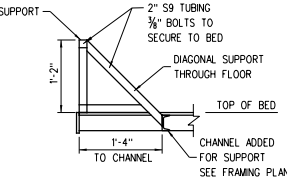

- NOTES:
1. DIAGONAL SUPPORT TO GO THROUGH FLOOR AND BE SUPPORTED AND WELDED TO CHANNEL. SEE FRAMING PLAN.
 2. CHANNEL SUPPORT IS TO BE C3x1.73'S.
 3. WELD GATE SUPPORT TO 4" PLATE.
 4. SECURE TO BED WITH 3/8" BOLTS.

04 SIGN POST HOLDER DETAIL

NOT TO SCALE

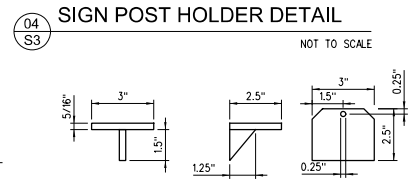

05 HEADBOARD PLATE DETAIL

AS NOTED

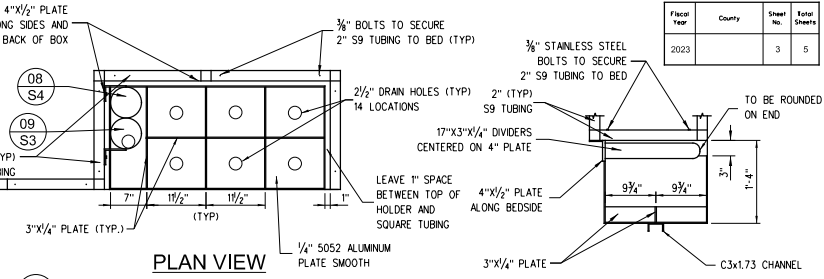
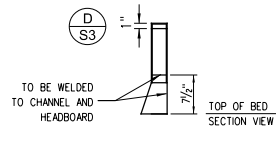

PLAN VIEW

SECTION VIEW

- NOTES:
1. DIVIDERS SHALL BE 1/4"x4" FLAT BAR 60616 AND ROUNDED ON ENDS. DIVIDERS SHALL BE WELDED TO 4" PLATE ALONG BEDSIDE.
 2. 3/8" STAINLESS STEEL BOLTS USED TO SECURE 1/2" SQUARE TUBING TO BED.
 3. MUD FLAP HOLDER TO BE PLACED 1" FROM FRONT OF BOX.

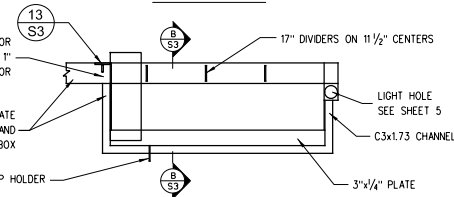

06 GATE BRACKET DETAIL

NOT TO SCALE

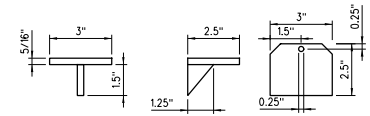

07 SAFETY GATE DETAIL

NOT TO SCALE

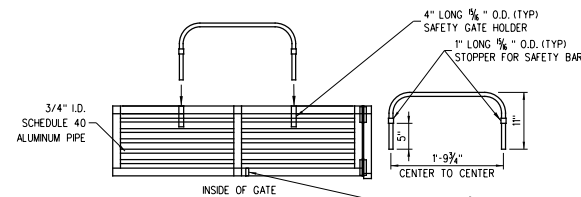

- NOTES:
1. SAFETY GATE TO BE 3/4" SOLID ROD WITH TWO (2) STOPPERS WELDED TO BAR. STOPPERS TO BE SAME SIZE AS GATE HOLDERS. SEE DIMENSIONS IN DETAIL ABOVE.
 2. SAFETY GATE HOLDERS TO BE INSTALLED IN FOUR (4) LOCATIONS. TWO (2) ABOVE CONE BOX ON BOTH SIDES OF THE TRUCK AS SHOWN IN CONE BOX DETAIL. TWO (2) TO BE INSTALLED ON THE GATE ON BOTH SIDES OF THE TRUCK.

08 FLAG HOLDER DETAIL

NOT TO SCALE

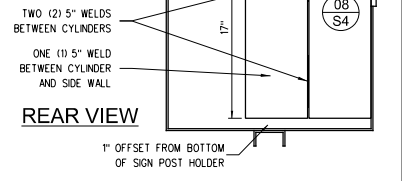

- NOTES:
1. FLAG HOLDER TO BE PLACED ON BOTH SIDES OF TRUCK

HNTB HNTB CORPORATION
ENGINEERS ARCHITECTS PLANNERS

WEST VIRGINIA TURNPIKE
MGT TRUCK BED

SPECIAL DETAILS

REVISION NUMBER	SHEET NUMBER	REVISION	DATE	BY

SCALE : 0 1 R

Thursday, July 13, 2023

F:\318192_WPA_07-1-21_Forensic_and_Requests\MTB-1-23\Sheet304 Detail Sheet.dwg

Fiscal Year	County	Sheet No.	Total Sheets
2023		4	5

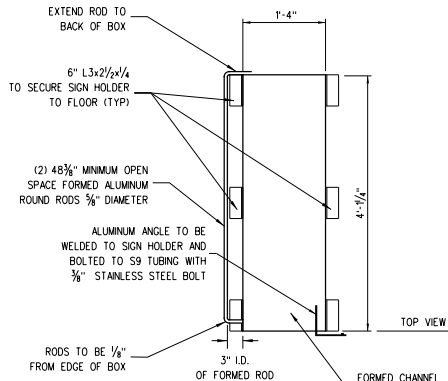

- NOTES:
- 3"x16"x3 3/8" THICK FORMED CHANNEL TO BE USED ON TOP AND BOTTOM OF SIGN HOLDER BOX.
 - 4"x1/2" THICK PLATES ON FRONT OF SIGN HOLDER BOX.
 - 4"x16"x4 3/8" THICK FORMED CHANNEL TO BE USED ON THE BACK OF SIGN HOLDER BOX.
 - ALUMINUM PLATE TO BE 5052 ALUMINUM SMOOTH 3/8" THICK. ALL REMAINING STRUCTURE TO BE 6061T6 ALUMINUM.
 - ALL 48" SIGNS NEED TO FIT AND NOT FALL OUT BUT HAVE SLACK FOR PLACEMENT AND REMOVAL.
 - TOP ANGLE TO BOTTOM ANGLE SHOULD EQUAL 48 3/8", NO LESS.
 - 1/4"x1 1/4"x1/4" ALUMINUM ANGLE, DRILL 3/8" HOLES, PLUG WELD TO FRAME.

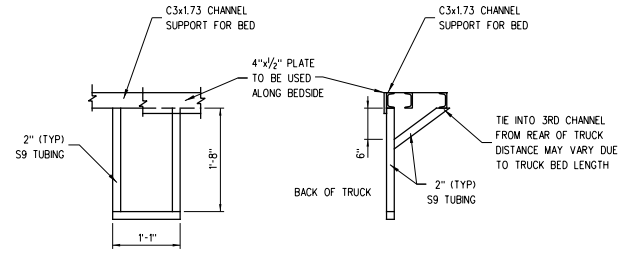

- NOTES:
- STEP TO BE SECURED TO C3X1.73 BED FRAME CHANNEL AND BACK OF 4"x1/2" BEDSIDE PLATE.
 - STEP HEIGHT TO BE 1'-8" BELOW CHANNEL AND 10" WIDE INSIDE DIMENSION.
 - STEP TO BE ALUMINUM BUSTIN STEP MATERIAL 2" WIDE X 1 1/2" HIGH. PART NO. DE0604, MODEL NO. 627.

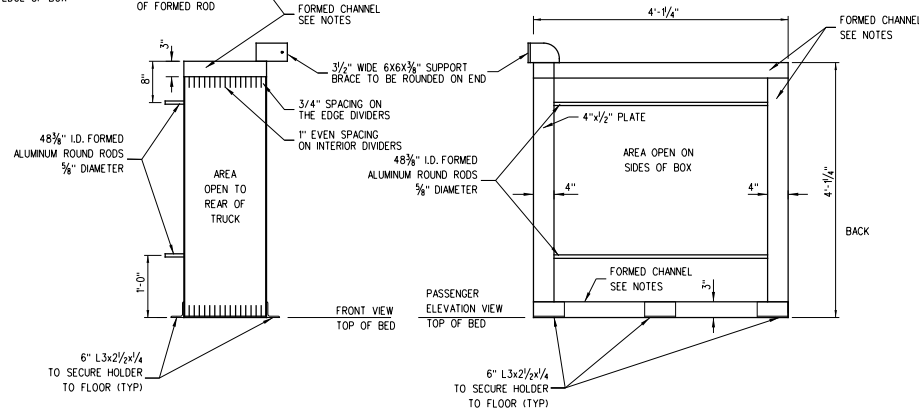

07 S4 REAR STEP DETAIL

SCALE: AS NOTED

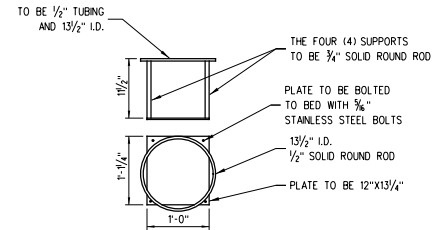

- NOTES:
- WATER COOLER HOLDER TO BE 1/2" SOLID ROUND ROD AND TO HAVE 1 3/2" INSIDE DIAMETER.
 - THE FOUR (4) SUPPORTS TO BE 3/4" SOLID ROUND ROD.
 - THE TOP OF THE HOLDER TO BE 1 1/2" ABOVE THE TOP OF PLATE.
 - PLATE TO BE FLUSH WITH THE SIDE OF BED.
 - A. PLATE TO BE BOLTED TO BED WITH FOUR (4) 3/8" STAINLESS STEEL BOLTS.
 - B. PLATE TO BE OFFSET FROM SIGN POST HOLDER 3".
 - C. PLATE DIMENSIONS 12"x13 1/4"x1/4" THICK.
 - A REPLACEMENT WATER COOLER HOLDER, IN ADDITION TO THE ONE PLACED ON THE TRUCK, TO BE BUILT WITH EACH TRUCK BED.

10 S4 WATER COOLER DETAIL

SCALE: AS NOTED

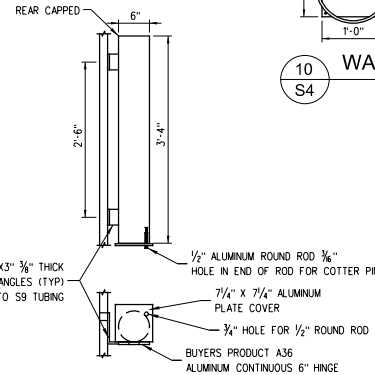

- NOTES:
- SPEED LIMIT SIGN HOLDER TO BE 6" ALUMINUM PIPE 40" LONG.
 - A. CAPPED ON END FACING FRONT OF TRUCK.
 - B. OPEN TO REAR OF TRUCK WITH ALUMINUM PLATE COVER.
 - TWO (2) 6X6X3 3/8" THICK ALUMINUM ANGLES TO CONNECT SPEED LIMIT SIGN HOLDER TO S9 TUBING. TO BE WELDED TO PIPE AND BOLTED TO S9 TUBING WITH TWO (2) 3/8" STAINLESS STEEL BOLTS AT EACH LOCATION. TO BE PLACED ON 30" CENTERS. 1 3/4" SPACE TO BE BETWEEN 6" PIPE AND ALUMINUM ANGLE.
 - WELD A 1/2" ALUMINUM ROUND ROD 4" LONG TO THE 6" PIPE.
 - A. ROUND ROD SHOULD EXTEND FROM PIPE 1" TO BE USED TO LOCK PLATE COVER ON THE END OF PIPE.
 - B. A 3/8" HOLE TO BE DRILLED THROUGH ROUND ROD AT END FOR COTTER PIN.
 - 6" HINGE TO BE BUYERS PRODUCT A36 ALUMINUM CONTINUOUS HINGE.

11 S4 SPEED LIMIT SIGN HOLDER DETAIL

SCALE: AS NOTED

06 S4 SIGN HOLDER DETAIL

SCALE: AS NOTED

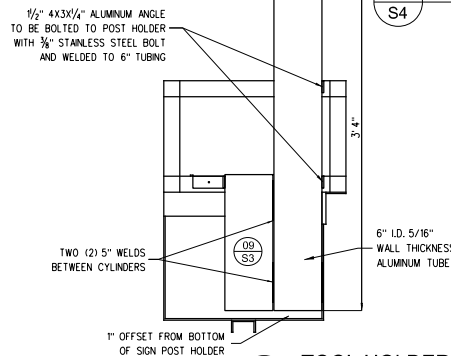

- NOTES:
- TWO (2) 6" I.D. 5/8" WALL THICKNESS ALUMINUM TUBING, ATTACHED TO FRONT OF HOLDER BOX BY 3/2" 6X6X3/8" ALUMINUM ANGLE.
 - TUBING SHALL BE OFFSET FROM WALL 3" AT THE FRONT END OF THE SIGN POST HOLDER.
 - THERE SHALL BE A 1" OFFSET FROM THE TOP OF BED TO THE BOTTOM OF THE TOOL HOLDER.
 - SEE FLAG HOLDER DETAIL FOR ADDITIONAL VIEWS.

08 S4 TOOL HOLDER DETAIL

SCALE: AS NOTED

HNTB HNTB CORPORATION
ENGINEERS ARCHITECTS PLANNERS

WEST VIRGINIA TURNPIKE
MOT TRUCK BED

SPECIAL DETAILS

SCALE: 0 1 R

REVISION NUMBER	SHEET NUMBER	REVISION	DATE	BY

Thursday, July 13, 2023 12:52 PM Project: West Virginia Turnpike and Request\MTB-1-23\Sheet304 Detail Sheet.dwg

Fiscal Year	County	Sheet No.	Total Sheets
2023		5	5

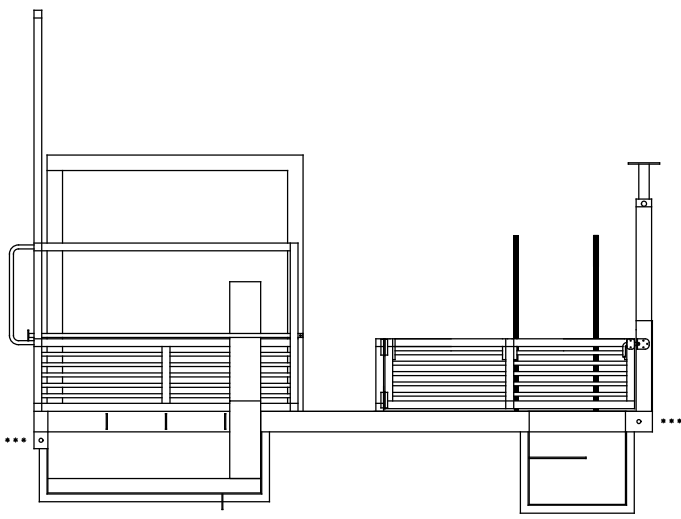

BEDSIDE ELEVATION VIEW

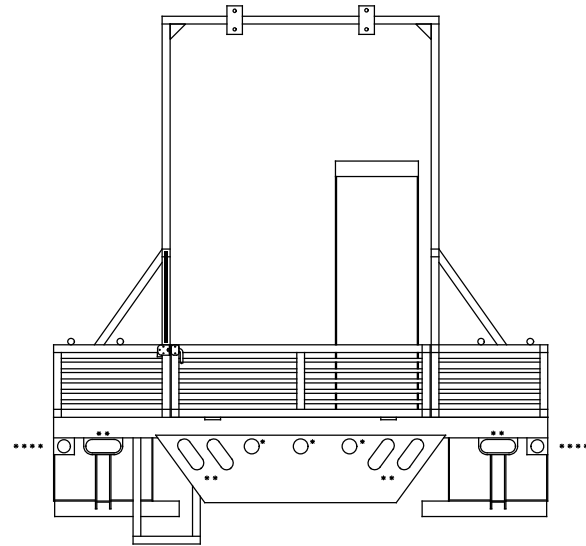

REAR ELEVATION VIEW

LIGHT HOLE SIZES

- 2 3/8" DIAMETER
- 6 3/4" DIAMETER - 2 3/8" DIAMETER EACH END
- 3/4" DIAMETER
- 2 1/2" DIAMETER (TYP)

HNTB HNTB CORPORATION
ENGINEERS ARCHITECTS PLANNERS

WEST VIRGINIA TURNPIKE
MGT TRUCK BED
LIGHTING PLAN

SCALE : 0 1 R

REVISION NUMBER	SHEET NUMBER	REVISION	DATE	BY

F:\31875.wpa_07-1-21_Formal_45970\A\31875_Misc_Projects_and_Requests\MTB-1-23\Sheet\05_Lighting_Plan.dgn
 Thursday, July 13, 2023

F:\31875.wpa_07-1-21_Formal_45970\A\31875_Misc_Projects_and_Requests\MTB-1-23\Sheet\05_Lighting_Plan.dgn
 Thursday, July 13, 2023

SUBMISSION PAGE

FABRICATED ALUMINUM TRAFFIC CONTROL TRUCK BED

BID OPENING: 8/13/24

1 UNIT – TO BE PICKED UP BY PARKWAYS AUTHORITY

PRICE _____ = TOTAL COST

SUBMITTED BY:

COMPANY NAME _____

ADDRESS _____

PHONE NUMBER _____

FAX NUMBER _____

EMAIL ADDRESS _____

COMPANY CONTACT _____

SIGNATURE _____

VENDOR REGISTRATION NUMBER _____

www.wvoasis.gov

STATE OF WEST VIRGINIA
Purchasing Division

PURCHASING AFFIDAVIT

CONSTRUCTION CONTRACTS: Under W. Va. Code § 5-22-1(i), the contracting public entity shall not award a construction contract to any bidder that is known to be in default on any monetary obligation owed to the state or a political subdivision of the state, including, but not limited to, obligations related to payroll taxes, property taxes, sales and use taxes, fire service fees, or other fines or fees.

ALL CONTRACTS: Under W. Va. Code §5A-3-10a, no contract or renewal of any contract may be awarded by the state or any of its political subdivisions to any vendor or prospective vendor when the vendor or prospective vendor or a related party to the vendor or prospective vendor is a debtor and: (1) the debt owed is an amount greater than one thousand dollars in the aggregate; or (2) the debtor is in employer default.

EXCEPTION: The prohibition listed above does not apply where a vendor has contested any tax administered pursuant to chapter eleven of the W. Va. Code, workers' compensation premium, permit fee or environmental fee or assessment and the matter has not become final or where the vendor has entered into a payment plan or agreement and the vendor is not in default of any of the provisions of such plan or agreement.

DEFINITIONS:

"Debt" means any assessment, premium, penalty, fine, tax or other amount of money owed to the state or any of its political subdivisions because of a judgment, fine, permit violation, license assessment, defaulted workers' compensation premium, penalty or other assessment presently delinquent or due and required to be paid to the state or any of its political subdivisions, including any interest or additional penalties accrued thereon.

"Employer default" means having an outstanding balance or liability to the old fund or to the uninsured employers' fund or being in policy default, as defined in W. Va. Code § 23-2c-2, failure to maintain mandatory workers' compensation coverage, or failure to fully meet its obligations as a workers' compensation self-insured employer. An employer is not in employer default if it has entered into a repayment agreement with the Insurance Commissioner and remains in compliance with the obligations under the repayment agreement.

"Related party" means a party, whether an individual, corporation, partnership, association, limited liability company or any other form or business association or other entity whatsoever, related to any vendor by blood, marriage, ownership or contract through which the party has a relationship of ownership or other interest with the vendor so that the party will actually or by effect receive or control a portion of the benefit, profit or other consideration from performance of a vendor contract with the party receiving an amount that meets or exceeds five percent of the total contract amount.

AFFIRMATION: By signing this form, the vendor's authorized signer affirms and acknowledges under penalty of law for false swearing (W. Va. Code §61-5-3) that: (1) for construction contracts, the vendor is not in default on any monetary obligation owed to the state or a political subdivision of the state, and (2) for all other contracts, that neither vendor nor any related party owe a debt as defined above and that neither vendor nor any related party are in employer default as defined above, unless the debt or employer default is permitted under the exception above.

WITNESS THE FOLLOWING SIGNATURE:

Vendor's Name: _____

Authorized Signature: _____ Date: _____

State of _____

County of _____, to-wit:

Taken, subscribed, and sworn to before me this ____ day of _____, 20__.

My Commission expires _____, 20__.

AFFIX SEAL HERE

NOTARY PUBLIC _____

Purchasing Affidavit (Revised 01/19/2018)

AGREEMENT ADDENDUM

In the event of conflict between this addendum and the agreement, this addendum shall control:

1. **DISPUTES** - Any references in the agreement to arbitration or to the jurisdiction of any court are hereby deleted.
2. **HOLD HARMLESS** - Any provision requiring the Agency to indemnify or hold harmless any party is hereby deleted in its entirety.
3. **GOVERNING LAW** - The agreement shall be governed by the laws of the State of West Virginia. This provision replaces any references to any other State's governing law.
4. **TAXES** - Provisions in the agreement requiring the Agency to pay taxes are deleted. As a State entity, the Agency is exempt from Federal, State, and local taxes and will not pay taxes for any Vendor including individuals, nor will the Agency file any tax returns or reports on behalf of Vendor or any other party.
5. **PAYMENT** - Any references to prepayment are deleted. Payment will be in arrears.
6. **INTEREST** - Any provision for interest or charges on late payments is deleted. The Agency has no statutory authority to pay interest or late fees.
7. **NO WAIVER** - Any language in the agreement requiring the Agency to waive any rights, claims or defenses is hereby deleted.
8. **FISCAL YEAR FUNDING** - Service performed under the agreement may be continued in succeeding fiscal years for the term of the agreement, contingent upon funds being appropriated by the Legislature or otherwise being available for this service. In the event funds are not appropriated or otherwise available for this service, the agreement shall terminate without penalty on June 30. After that date, the agreement becomes of no effect and is null and void. However, the Agency agrees to use its best efforts to have the amounts contemplated under the agreement included in its budget. Non-appropriation or non-funding shall not be considered an event of default.
9. **STATUTE OF LIMITATION** - Any clauses limiting the time in which the Agency may bring suit against the Vendor, lessor, individual, or any other party are deleted.
10. **SIMILAR SERVICES** - Any provisions limiting the Agency's right to obtain similar services or equipment in the event of default or non-funding during the term of the agreement are hereby deleted.
11. **FEES OR COSTS** - The Agency recognizes an obligation to pay attorney's fees or costs only when assessed by a court of competent jurisdiction. Any other provision is invalid and considered null and void.
12. **ASSIGNMENT** - Notwithstanding any clause to the contrary, the Agency reserves the right to assign the agreement to another State of West Virginia agency, board or commission upon thirty (30) days written notice to the Vendor and Vendor shall obtain the written consent of Agency prior to assigning the agreement.
13. **LIMITATION OF LIABILITY** - The Agency, as a State entity, cannot agree to assume the potential liability of a Vendor. Accordingly, any provision limiting the Vendor's liability for direct damages to a certain dollar amount or to the amount of the agreement is hereby deleted. Limitations on special, incidental or consequential damages are acceptable. In addition, any limitation is null and void to the extent that it precludes any action for injury to persons or for damages to personal property.
14. **RIGHT TO TERMINATE** - Agency shall have the right to terminate the agreement upon thirty (30) days written notice to Vendor. Agency agrees to pay Vendor for services rendered or goods received prior to the effective date of termination.
15. **TERMINATION CHARGES** - Any provision requiring the Agency to pay a fixed amount or liquidated damages upon termination of the agreement is hereby deleted. The Agency may only agree to reimburse a Vendor for actual costs incurred or losses sustained during the current fiscal year due to wrongful termination by the Agency prior to the end of any current agreement term.
16. **RENEWAL** - Any reference to automatic renewal is deleted. The agreement may be renewed only upon mutual written agreement of the parties.
17. **INSURANCE** - Any provision requiring the Agency to purchase insurance for Vendor's property is deleted. The State of West Virginia is insured through the Board of Risk and Insurance Management, and will provide a certificate of property insurance upon request.
18. **RIGHT TO NOTICE** - Any provision for repossession of equipment without notice is hereby deleted. However, the Agency does recognize a right of repossession with notice.
19. **ACCELERATION** - Any reference to acceleration of payments in the event of default or non-funding is hereby deleted.
20. **CONFIDENTIALITY** - Any provision regarding confidentiality of the terms and conditions of the agreement is hereby deleted. State contracts are public records under the West Virginia Freedom of Information Act.
21. **AMENDMENTS** - All amendments, modifications, alterations or changes to the agreement shall be in writing and signed by both parties. No amendment, modification, alteration or change may be made to this addendum without the express written approval of the Purchasing Division and the Attorney General.

ACCEPTED BY:

WEST VIRGINIA PARKWAYS AUTHORITY,
an agency of the State of West Virginia

VENDOR

Company Name: _____

Signed: _____

Signed: _____

Title: _____

Title: _____

Date: _____

Date: _____

GENERAL TERMS & CONDITIONS
REQUEST FOR QUOTATION (RFQ) AND REQUEST FOR PROPOSAL (RFP)

1. Award will be made in the best interest of the West Virginia Parkways Authority.
2. The Authority may accept or reject in part, or in whole, any proposal.
3. All quotations are governed by the West Virginia Code and the Legislative Rules of the Purchasing Division and The Authority's purchasing rules.
4. Prior to any award, the apparent successful vendor must be properly registered with the Purchasing Division and have paid the required registration fee.
5. Payment may only be made after the delivery and acceptance of goods or services.
6. Interest may be paid for late payment in accordance with the West Virginia Code.
7. Vendor preference, if applicable, will be granted upon written request in accordance with the West Virginia Code.
8. Agencies of The State of West Virginia are exempt from federal and state taxes and will not pay or reimburse such taxes.
9. The Authority's Director of Purchasing may cancel any Purchase Order/Contract upon 30 days written notice to the vendor.
10. The laws of the State of West Virginia and the Legislative Rules shall govern all rights and duties under the Contract, including without limitation the validity of this Contract.
11. Any reference to automatic renewal is hereby deleted. The Contract may be renewed only upon mutual written agreement of the parties.
12. BANKRUPTCY: In the event the vendor/contractor files for bankruptcy protection, this Contract may be deemed null and void, and terminated without further order.
13. HIPAA Business Associate Addendum - The West Virginia State Government HIPAA Business Associate Addendum (BAA), approved by the Attorney General, and available online at the Purchasing Division's web site (<http://www.state.wv.us/admin/purchase/vrc/hipaa.htm>) is hereby made part of the agreement. Provided that, the Agency meets the definition of a Covered Entity (45 CFR §160.103) and will be disclosing Protected Health Information (45 CFR §160.103) to the vendor.

INSTRUCTIONS TO VENDORS

1. Use the RFP/RFQ forms provided by the Authority.
 2. SPECIFICATIONS: Services offered must be in compliance with the provisions of the RFP/RFQ. Any deviations must be clearly indicated by the proposer in the proposal. Alternates offered by the proposer as EQUAL to those specified in the RFP/RFQ must be clearly defined. The Authority, because of the unique nature of the services to be provided under the RFP/RFQ, may decide not to accept EQUAL services under the RFP/RFQ. A proposed offering an alternate should attach complete specifications and literature to the proposal. The Purchasing Director may waive minor deviations to certain requirements.
 3. Complete all sections of the proposal form.
 4. Unit prices shall prevail in cases of discrepancy.
 5. All quotations are considered F.O.B. destination unless alternate shipping terms are clearly identified in the quotation.
 6. PROPOSAL SUBMISSION: All quotations must be delivered by the proposer to the office listed prior to the date and time of the proposal opening. Failure to deliver the proposal on time will result in disqualifications.
- Rev. 12/28/16*

WV PARKWAYS AUTHORITY
Purchasing Departmen