

Standards Committee

Meeting Agenda

Wednesday, September 11, 2024, at 9:00am

Meeting Location: 1900 Kanawha Blvd. E., Building 5, Room 820, Charleston, WV

Also meeting virtually via Google Meet. E-mail distribution includes instruction.

Call to Order

Roll Call of Attendees

Approval of Minutes of 7/3/2024 Meeting

Unfinished Business – Standards discussed at last Committee meeting.

TITLE	Champion
<p>2nd time to Committee.</p> <p><i>Standard Drainage Details.</i> Inlet and Manhole details with a 6” thickness. They have 28-day strengths of 5000 psi and include a note (12) which is their version of, “Flow of outlet pipe shall match bottom elevation of inlet.”</p> <p>No Comments have been received.</p> <p>Expected to go to vote in September.</p>	A. Gillispie

New Business

TITLE	Champion
<p>1st time to Committee.</p> <p><i>DD-202 Review Submission Checklists: PFR, FFR, FOR.</i> MS4 Coordination added to each checklist.</p> <p>Expected to go to vote in November.</p>	D. Begley

TITLE	Champion
<p>1st time to Committee.</p> <p><i>DD-202 Distribution Schedule:</i> HE added to schedule</p> <p>Note: This list isn’t required to go through the Standards Committee for updates, but we’ve included it so that others can provide input or further updates, if needed.</p>	D. Begley

TITLE	Champion
<p>1st time to Committee.</p> <p><i>DD-202 Regional Maps:</i> Maps updated with current staff.</p> <p>Note: This list isn't required to go through the Standards Committee for updates, but we've included it so that others can provide input or further updates, if needed.</p>	<p>D. Begley</p>

TITLE	Champion
<p>1st time to Committee.</p> <p><i>DD-105 Specification, Standards, Manuals, & Material Procedure Approval Process:</i> Link and Division Updates.</p> <p>Expected to go to vote in November.</p>	<p>J. Adkins</p>

Next Meeting Date: Wednesday, November 6, 2024.

Deadline for submissions: October 16, 2024.

Adjournment

**Standards Committee
Meeting Minutes
July 3, 2024**

Call to Order: The meeting was called to order by Acting Chair Dee Begley shortly after 9:00 AM.

Attendees: See Attendee List for a list of attendees.

Minutes: Minutes of the 5-1-2024 Meeting were reviewed; there were no comments on them.

Unfinished Business: Items which were discussed at prior meeting are listed below:

TITLE	Champion
<p>2nd time to Committee.</p> <p><i>Design Directive (DD)-202 Field and Office Reviews for Initial Engineering, Preliminary Engineering and Final Design. DD-202 Plan Distribution Schedule.</i></p> <p>Various personnel changes were updated.</p> <p>Note: This list isn't required to go through the Standards Committee for updates, but we've included it so that others can provide input or further updates, if needed.</p> <p>Updates were finalized and updated on the website.</p>	D. Begley
<p>2nd time to Committee.</p> <p><i>Structure Directive (SD)-1045 Foundation Types.</i> Updates the approval requirements of Intermediate Geomaterial and typos were corrected.</p> <p>Passed with a vote of 5-0.</p>	R. Scites

New Business: Items discussed for the first time at committee meeting are listed below:

TITLE	Champion
<p>1st time to Committee.</p> <p><i>Standard Drainage Details.</i> Inlet and Manhole details with a 6" thickness. They have 28-day strengths of 5000 psi and include a note (12) which is their version of, "Flow of outlet pipe shall match bottom elevation of inlet."</p> <p>No comments were received.</p>	A. Gillispie

Next Meeting: The next meeting is on Wednesday, September 11, 2024. Deadline for submissions August 21, 2024.

Adjournment: The meeting was adjourned.

Manuals Committee
Meeting Minutes
July 3, 2024

Call to Order: The meeting was called to order by Acting Chair Dee Begley shortly after conclusion of Standards Committee meeting.

Attendees: See Attendee List for a list of attendees.

Unfinished Business: Items which were discussed at prior meeting are listed below:

I. None

New Business: Items which were discussed for the first time at the committee meeting are listed below:

II. None

Next Meeting: The next meeting is on Wednesday, September 11, 2024. Deadline for submissions August 21, 2024.

Adjournment: The meeting was adjourned.

July Standards & Manuals Committee Meeting
Wednesday, July 3, 2024
Attendee List

Virtual Meeting Attendees

- | | |
|------------------------|--------------------------------------|
| 1. Dan Brayack | WVDOH – Materials Division |
| 2. Phil Brown | WVDOH – Material Division |
| 3. Gary Mullins | WVDOH – Materials Division |
| 4. Ted Whitmore | WVDOH – Traffic Engineering Division |
| 5. John Crane | CAWV |
| 6. Jason Foster | WVDOH – Chief of Development |
| 7. Jeremiah Knavenshue | MBI |
| 8. Dohn Lough | WVDOH |
| 9. Barrett Neeley | WVDOH – District 1 |
| 10. Andrew Thaxton | WVDOH – Materials |
| 11. Chris West | |
| 12. Ahmed Mongi | HDR |
| 13. Adam Gillispie | WVDOH – Materials Division |

In Person Meeting Attendees

- | | |
|-------------------|--|
| 1. Janie Adkins | WVDOH – Technical Support Division |
| 2. Deidra Begley | WVDOH – Technical Support Division |
| 3. Dakota Smith | WVDOH – Engineering Division |
| 4. David Chappell | WVDOH – Traffic Engineering |
| 5. Shawn Smith | WVDOH – Contract Administration Division |
| 6. Travis Long | WVDOH – Technical Support Division |
| 7. Elliot King | WVDOH – Executive Co-Op |

TOTAL ATTENDEES: 20

**WEST VIRGINIA DEPARTMENT OF TRANSPORTATION
DIVISION OF HIGHWAYS**

**DESIGN DIRECTIVE 105
SPECIFICATION, STANDARDS, MANUALS, AND MATERIAL PROCEDURE
APPROVAL PROCESS**

August 25, 2021

Supersedes August 1, 2019

This Design Directive outlines the procedure that has been accepted by the Division for preparing and processing proposed Specifications and Special Provisions, Standards, Manuals, and Material Procedures for approval. The Publications Section of the Technical Support Division consists of three units: Specifications, Standards, and Manuals. The Materials Control, Soils, and Testing Division is the home division of the Materials Procedures.

10. Specifications

The general processing of Specifications and Special Provisions is administered through the Technical Support Division by the Specification Engineer.

Standard Specifications will be issued periodically as the need dictates. Supplemental Specifications to accompany the Standard Specifications are issued annually on January 1st and are effective on all projects let to contract thereafter. Each new Supplemental Specification replaces the previous one and incorporates changes from all previous supplemental specifications.

A searchable version of the Standard Specifications book and Supplemental Specifications is available from the Specifications webpage, located online at <http://transportation.wv.gov/highways/contractadmin/specifications/>

<https://transportation.wv.gov/highways/TechnicalSupport/specifications/Pages/default.aspx>

10.1 Procedure for Processing Specification Changes

Permanent specifications changes to the Standard Specifications or Supplemental Specifications should be submitted electronically to DOHSpecifications@wv.gov by the 'champion'. The originating Division will prepare the specification changes in a format conforming to Design Directive 820. A brief overview of the item and background information with reason for the changes should accompany the request.

The Specifications Engineer will review all recommendations received and transmit to the Specifications Committee for action. The champion should attend all committee meetings pertaining to their respective specification. A proposed specification must be presented at two committee meetings before it can be recommended or rejected by the Specifications Committee.

10.2 Procedure for Processing Special Provisions for Individual Projects

There may be a need to use an innovative product or an experimental procedure to address unique demands of a project. Often, these items are not covered by existing

specifications, so they may require new or modified specifications to describe their material requirements, construction requirements and payment. Special Provisions (SPs) are written to address these situations.

Before drafting a SP, check with the Specifications Engineer (or ProjectWise folder: ~~Approved Project Specific Provisions (PDF)~~) to determine if a SP already exists that meets the needs of the project.

SPs are processed as outlined above in 10.1. In general, the originating Division should submit proposed SP at least six months prior to their project's PS&E submission. This provides adequate time to process and resubmit any changes that may be requested by the committee.

When time does not permit this procedure, the following procedures should be followed:

- a. The originating Division will prepare the draft Special Provision in a format conforming to Design Directive 820, coordinating with the Technical Support Division, Specifications Engineer for review, comment, assignment of an appropriate section number and/or pay item number.
- b. The originating Division will secure the approval of the Applicable Deputy State Highway Engineer and the Federal Highway Administration as appropriate for that project. The approval of the Special Provision would only apply to the specific project. The submission for approval shall follow Design Directive 202 and may only encompass the PS&E package for advertising the project.

There are Project Specific Special Provisions that require management approval prior to their use on projects. These are listed in ProjectWise subfolder title "Requires Management Approval". The Project Manager shall provide justification of why the SP is needed to the Appropriate Deputy State Highway Engineer for approval.

10.3 Specifications Committee

The Specifications Committee review and recommend actions to proposed Specifications and Special Provisions. The committee meets on call by the Specifications Engineer with regular meetings scheduled every other month and follow the Open Government Meeting Act. Details of this act are available at: <https://ethics.wv.gov/openmeetings/Pages/default.aspx>.

The Specifications Committee consists of voting and non-voting members who provide expertise to review and recommend action of the proposed Specifications and Special Provisions. The committee requests comments on the provisions in the meeting agenda; and review/discuss them during the meeting. The committee meeting agenda will designate the items that are up for approval and dependent upon comments/discussion/changes the Specifications Engineer has the right to call for a vote on the final version.

The voting members consist of one representative from each of the following Divisions:

- Contract Administration Division
- Engineering Division
- Materials Control, Soil and Testing Division
- Operations Division
- Traffic Engineering Division

A quorum of 3 voting members must exist for the meeting to be valid. A majority of the present voting members is required to pass the proposed item. The Specifications Engineer

shall have the authority to cast the deciding vote when a tie occurs. All approved specification changes will be sent to FHWA for comment and concurrence.

The non-voting members consist of one or more representatives from the following agencies: Federal Highway Administration, Contractors Association of West Virginia, ACEC – WV, Asphalt Pavement Association of West Virginia, American Concrete Pavement Association, Builders Supply Association of West Virginia, various vendors, and anyone from the Division or Industry that has knowledge of the specifications being discussed.

10.4 Coordination of Specifications, Special Provisions, and Project Plans

The Specifications, Supplemental Specifications, Special Provisions, and project plans are essential parts of the Contract; and a requirement occurring in one is as binding as though occurring in all. In case of discrepancy, Supplemental Specifications will govern over Specifications; Plans will govern over Specifications and Supplemental Specifications; Special Provisions will govern over Specifications, Supplemental Specifications, and Plans as prescribed in Section 105.4 of the Standard Specifications. Below is a graphic display of the hierarchy of contract documents; where the items shown above, govern over items below it.

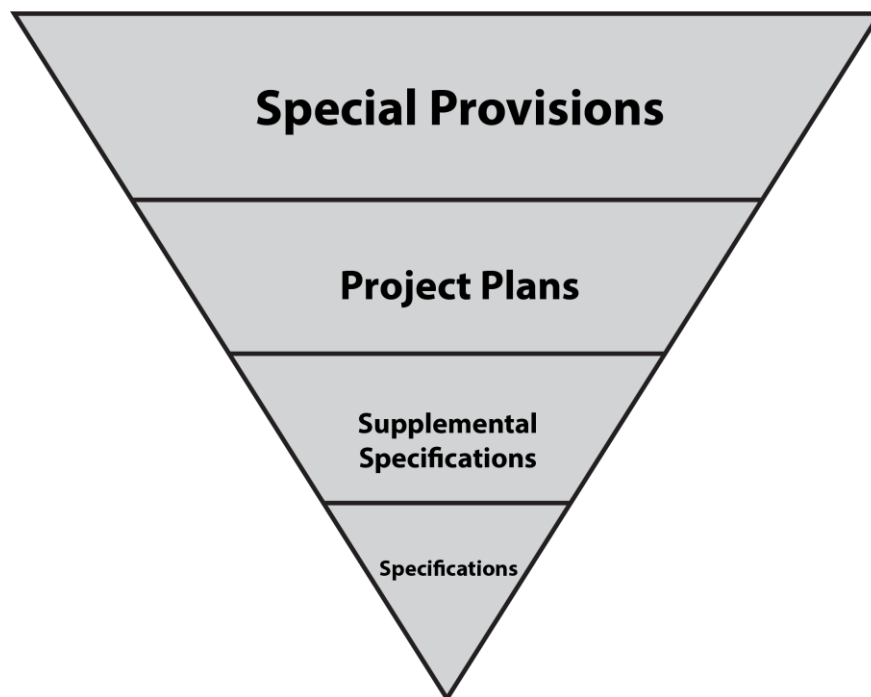

Project plans or plan notes should not be used to change specifications. The procedure outlined in this Design Directive should be utilized when this is necessary.

20. Standards and Manuals

The general processing of Standards and Manuals is administered through the Technical Support Division by the Standards Unit Leader and the Manual Unit Leader.

Standards and Manuals will be issued periodically as the need dictates. Each revised edition supersedes the previous one and incorporates changes from all previous editions.

These publications are available in electronic format on the Division of Highways' ~~Engineering~~ Division Publications webpage, located online at

~~<https://transportation.wv.gov/highways/engineering/Pages/publications.aspx>~~

<https://transportation.wv.gov/highways/TechnicalSupport/Pages/Publication-Group.aspx>

20.1 Procedure for Processing Standards or Manuals Changes

Proposed changes to any of the Division of Highways' Standards or Manuals should be submitted electronically to the Technical Support Division's Standards or Manuals Unit Leader, as appropriate. The originating Division will prepare the document changes in a format conforming to that particular document. A brief overview of the document and background information with reasons for the changes should accompany the request.

The Standards or Manuals Unit Leader will review all recommendations received and transmit them to the Standards Committee (formally known as Technical Publications Committee) or Manuals Committee for action. A proposed standard or manual or revisions to an existing document must be presented at two committee meetings before it can be recommended or rejected by the Standards or Manuals Committee, unless considered by the committee to be a minor change.

20.2 Standards Committee and Manuals Committee

The Standards or Manuals Committee will review and recommend actions to proposed standards, manuals, or revisions to existing documents. The committee meets on call by the appropriate Unit Leader with regular Standards Committee meetings scheduled every other month (and as needed) and follow the Open Government Meeting Act. Details of this act are available at: <https://ethics.wv.gov/openmeetings/Pages/default.aspx>.

The Standards and Manuals Committee consists of voting and non-voting members who provide expertise to review and recommend action of the proposed standard or manual. The committee requests comments on the standard or manual in the meeting agenda; and reviews/discusses them during the meeting. The committee meeting agenda will designate the items that are up for approval and dependent upon comments/discussion/changes the presiding unit leader has the right to call for a vote on the final version.

The voting members consist of one representative from each of the following Divisions:

- Contract Administration Division
- Engineering Division
- Materials Control, Soil and Testing Division
- Operations Division
- Traffic Engineering Division

A quorum of 3 voting members must exist for the meeting to be valid. A majority of the present voting members is required to pass the proposed item.

DD-202 PLAN DISTRIBUTION SCHEDULE

June 25, 2024

DIVISION/AGENCY	ELECTRONIC SUBMITTAL	LABEL	DESIGN REP.		CONTRACT PLAN DEVELOPMENT PROJECTS (Note 1)												Half-Size PS&E Plans
			FIELD REV.	OFFICE REV.	RW-1	PREL. FIELD REV.	RW-1 & RW-2 Comb.	SPAN ARR.	SLOPE REV.	COMB. TS&L	RW-2	FINAL FIELD REV.	RW-3	REV. RW-3 (Note 2)	FINAL OFFICE REV.	FINAL DET. BRIDGE PLANS	
FHWA (concurrency & nonexempt projects)	FHWA Area Engineers	FHWA-Area	C,X	C,X	R	C,X	R	C	C,X	C	R	C,X			C,X,S,W	C,S,W	C,X,S,W
Area Engineers	Jeffrey.Robinette@dot.gov	FHWA-R/W	N	N		N						N			N		
ROW Section	Bert.Buchanan@dot.gov	FHWA-Br.						C		C						C,S,W	C,S,W
Division Bridge Engineer	Raymond.J.Scites@wv.gov																
Engineering Division	David.P.Bodnar@wv.gov	DD	C,X	C,X		C,X		C	N	N		N	N	N	N	N	N
Roadway	Dirar.M.Ahmad@wv.gov Feras.Tolaymat@wv.gov	DDR/DDI(Road.)	C,X	C,X	R	C,X	R	C	C,X	C	R	C,X	R	R	C,X,S,W	C,S,W	C,X,S,W
PS&E	Michael.Carter@wv.gov	DDR (PS&E)															C, X, S, W
Bridge Review	Robert.L.Douglas@wv.gov	DDI						C		C		C, X			C,X,S,W	C,S,W	C, X, S, W
Bridge (If applicable)	Tim.A.Hermansdorfer@wv.gov	DDI(Br.)	C	C		C		C		C		C			C,S,W	C,S,W	C,S,W
Right-of-Way (Note 4)	Katrena.J.Parsons@wv.gov	DDR(R/W)			R	N	R				R	N	R,A	R	N		
Consultant Services	Erika.J.Carroll@wv.gov	DDC	C, N	C, N													
Initial Design	Mark.J.White@wv.gov	DDD	C, N	C, N													C
Traffic Engineering Division																	
Division Director	Ted.J.Whitmore@wv.gov	OS-Design	C	C		C						C					
Design	Rubina.Tabassum@wv.gov	OS-Design	C	C		C				C		C			C		C
Operations		OS-Operations	C	C		E						C					
Safety	Donna.J.Hardy@wv.gov	OS-Safety	C	C		C						C					
Traffic Services	Danny.G.Young@wv.gov	OS-Traffic Serv										C					
Technical Support Division																	
Geotechnical	Mark.A.Nettleton@wv.gov	DSG	C,X	C,X		C,X		C	C,X	C		C,X			C,X	C	
Environmental	Sondra.L.Mullins@wv.gov	DSN	C	C		C,X		C		C		C,X			C,X	C	C
Permitting	DOHNPDESPermitRequest@wv.gov DOH404PermitRequest@wv.gov	DSN	C	C		C		C		C		C			C	C	
Publications Section	Dee.L.Begley@wv.gov	DSP													C, N,S	C, N,S	C
Right-of-Way Division																	
Division Director	Chad.J.Toney@wv.gov	DR	N	N	N	N	N				N	N	N	N	N		
Estimator		DR-Est.	C	C		C						C,X			C		
Utilities	Sarah.L.Runyon@wv.gov	DR(Util.)	C	C		C				C		C			C		
Contract Administration Division	Shawn.A.Smith@wv.gov	FC				C,X		C		C		C,X			C,X,S,W	C,S,W	C,X,S,W
Materials Control, Soils, Testing Div.	Mike.A.Mance@wv.gov	FM													C,S	C,S	
Programming Division	Kenneth.T.Given@wv.gov	PP	C	C		C						C					C, E
Planning Division	Elwood.C.Penn@wv.gov	PR	C	C		C						C					
Chief Engineer Construction	Stephen.T.Rumbaugh@wv.gov	HF	C, N	C, N		N						N			N		N
Chief Engineer Development	Jason.C.Foster@wv.gov	HD	C, N	C, N		N						N			N		N
Chief Engineer of Environmental Compliance	Douglas.W.Kirk@wv.gov	HE	C			C		C		C		C			C	C	
Chief Engineer Operations	Joseph.M.Pack@wv.gov	HO	N	N		N			N			N			N		
Operations Division	Stephen.G.Johnson@wv.gov	OM				N						N			N		
District																	
District Engineer/Manager	Division of Highways Districts	D#-E/M	C,X	C,X		C		C		C		C			C,S,W	C,S,W	
District Development Engineer		D#-Devel	C,X	C,X		C		C		C		C					
Dist. Right-of-Way Agent		D#-R/W	C	C		C						C			C		
Dist. Bridge Eng.(If appl.)		D#-Bridge	C	C		N		C		C		N			N	C,S,W	
Dist. Const. Engineer		D#-Const.				C,X		C		C		C,X			C,X,S	C,S	
Dist. Util. Supervisor		D#-Util.				C						C			C		
Dist. Traffic Engineer		D#-Traffic	C	C								C			C		
DEP-Office of Water Resources		DEP Water Resources Map	DEP-OWR	C	C		C,X						C,X				
DNR Wildlife Resources	DNR Wildlife Resources Map	DNR-WR	2C	2C		2C,2X						2C,2X					
U. S. Army Corps of Engineers	sarah.m.workman@usace.army.mil	US-COE	C	C		C		C				C					
Railroad Company (If appl.)	Sarah.L.Runyon@wv.gov	DDR-RR	4C,4X			4C,4X				4C		4C,4X			4C,4X	4C	
Utility Companies Encountered	Utility Contact List	Util. Co. Name				C,X						C,X			C,X	C	
Other Appropriate Agencies			C	C		C						C			C	C	
MS4 Representative			C	C		C		C		C		C			C	C	
Commissioner's Office of Econ. Dev	Perry.J.Keller@wv.gov	CD	C	C		C									C	C	

NOTE 1: C = Const. plans or Design Report; R = R/W plans; N = Notification by PM; X = Cross sections; S = Project-specific special provisions; W = Working-time chart;
 E = All electronic plans in CADD format with electronic alignment files on acceptable media; A = Copy of asbestos inspection request memo to DDC+A1
 NOTE 2: Right of Way Plans (3R) shall include 1R with changes highlighted in red NOTE 3: All Corr. "H" & Rt. "9" projects contact CH(CR) for environmental agency distribution list NOTE 4: Submit in PDF format

**WEST VIRGINIA DIVISION OF HIGHWAYS
PRELIMINARY FIELD REVIEW SUBMISSION CERTIFICATION**

State Project No. _____
Federal Project No. _____
Project Name _____
County _____

Consultant _____
Project Manager _____
Submission Date _____

General Plan Requirements

_____ Construction Project Numbers Shown
_____ Line Weights Legible
_____ Contours Screened and Legible
_____ Adequate Spot Elevations Shown

Field Review Preparation

_____ Mainline Centerline Flagged at Sufficient Intervals for Field Review
_____ RW-1 Plans or RW-1 & RW-2 Combined Plans Submitted (DD-301)
_____ Value Engineering Review Required (DD-816)

Plan and Profile Sheets

_____ Alignment, Curve Data, and Superlevation Shown for Mainline and all Sideroads
_____ Stationing Shown for Mainline and all Sideroads
_____ Prel. Grades and Vertical Curve Data, Including K-Value, Shown for Mainline and all Sideroads
_____ Proposed Construction Limits Shown
_____ Property Lines Shown
_____ Disposition of all Crossroads, Railroads, and Streams or Rivers
_____ Channel Change Requirements Incorporating Natural Channel Design Features Shown
_____ Major Drainage Requirements, Including Pipe Profiles, Shown (DD-706)
_____ Major Erosion and Sediment Control Features on Plans and Cross Sections
_____ Proposed and Existing RW Limits Shown
_____ Existing Public & Private Utilities, Including Gas, Water, Septic, and Leach Fields for All Parcels, Shown (DD-303)

Typical Sections

_____ Mainline Typical
_____ Sideroad Typical
_____ Temporary Detour Typical

Cross Sections

_____ Mainline Sections at 200 foot Spacing and at Critical Locations
_____ Sideroad Sections at 200 foot Spacing and at Critical Locations
_____ Earthwork Based on Assumed Slopes
_____ Existing Topography, Including RW, Utilities, Bldg.'s, etc., Shown

Environmental Requirements

_____ Type of 404 Permit Documented (Individual or Nationwide)
_____ Certification of Familiarity with Environmental Documents
_____ List of Required Environmental Mitigations (DD-206)
_____ Listing and Explanation of Deviations to Design Report and Env. Documents
_____ Noise Mitigation or Noise Wall Justification
_____ **MS4 Coordination with Municipality**

Miscellaneous Sheets

_____ Title Sheet with Proposed Sheet Index (DD-701)
_____ Mass Diagram
_____ Interchange Geometric Layout
_____ Traffic Sketch Map (DD-802)
_____ Conceptual Maintenance of Traffic Scheme, Including Detours (DD-681)
_____ Traffic Routing Contingency Plan for Bridge/Structure Projects
_____ Property Maps, Ownership and Utility Index from RW-1 Plans (DD-301)

Boring Layout and Documents

_____ Boring Layout Shown on a Set of Topographic Plans
_____ Boring Bid Documents (Submitted after Preliminary Field Review) (DD-401)
_____ Boring Tabulation Showing all Pertinent Information (Submitted after Preliminary Field Review)

Preliminary Field Review Report

_____ Design Criteria Listing for Mainline and all Sideroads
_____ Access Point Cost Analysis (DD-307)
_____ Draft of required Design Exceptions

Miscellaneous Reports

_____ Major Drainage Calculations
_____ Geometric Calculations
_____ Total Project Construction Cost Estimate
_____ Consultant's Quality Control Markups

Notes: 1- All Lines to be initialed by Office Manager or responsible management level above the Project Manager
2- Use "NA" for any item not applicable to the project. Do not leave any items blank.

**WEST VIRGINIA DIVISION OF HIGHWAYS
FINAL FIELD REVIEW SUBMISSION CERTIFICATION**

State Project No. _____
 Federal Project No. _____
 Project Name _____
 County _____

Consultant _____
 Project Manager _____
 Submission Date _____

General Plan Requirements

_____ Construction Project Numbers Shown
 _____ Line Weights Legible
 _____ Contours Screened and Legible
 _____ Adequate Spot Elevations Shown
 _____ All Phases of Work Included in a Bid Item

Plan and Profile Sheets

_____ Alignment, Curve Data, and Superelvation Shown for Mainline and all Sideroads
 _____ Stationing Shown for Mainline and all Sideroads
 _____ Grades and Vertical Curve Data, Including K-Value, Shown for Mainline and all Sideroads
 _____ Construction Limits Shown
 _____ Property Lines Shown
 _____ Disposition of all Crossroads, Railroads, and Streams or Rivers
 _____ Channel Change Requirements Incorporating Natural Channel Design Features Shown
 _____ All Drainage Requirements Including Pipes, Pipe Profiles, Ditches, and Underdrains Shown (DD-706)
 _____ Major Erosion and Sediment Control Features on Plans and Cross Sections
 _____ Proposed and Existing RW Limits Shown
 _____ Utility Dispositions Shown (If Available)
 _____ Existing Public & Private Utilities, Including Gas, Water, Septic, and Leach Fields for All Parcels, Shown (DD-303)
 _____ Pavement/Surface Limits for All Roads
 _____ Site Plans for All Structures

Typical Sections

_____ Mainline Typical
 _____ Sideroad Typical
 _____ Pavement Edge/Shoulder Details
 _____ Pavement Design with Legend Including all Related Details
 _____ Temporary Detour Typical

Miscellaneous Sheets

_____ Title Sheet with Proposed Sheet Index (DD-701)
 _____ Summary of Quantities Showing List of Items Separated by Categories with Alternates at the End of Each Category (BAMS Format) (DD-705)
 _____ General Note Sheets (DD-704)
 _____ Quantity Tables without Quantities except Earthwork (DD-705)
 _____ Mass Diagram
 _____ Reference Point Sheet
 _____ Geometric Layout Sheet with Coordinates
 _____ Benchmarks Shown on Ref. Pt. Sheet, Geometric Layout Sheet, or Profile Sheet
 _____ Superelevation Shown for all Curves (DD-603)
 _____ Interchange Geometrics Shown
 _____ Intersection Layout Including Joint Layout
 _____ Complete Maintenance of Traffic Scheme Including Sequence of Construction (DD-681)
 _____ Traffic Routing Contingency Plan for Bridge/Structure Projects
 _____ Prel. Pavement Marking Layout (DD-682)
 _____ Preliminary Sign Layout (DD-683)
 _____ Preliminary Signal Layout
 _____ Preliminary Lighting Layout (DD-684)
 _____ All Required Ret. Wall and Culvert Details Shown
 _____ Any Required Special Detail Sheets
 _____ Property Maps, Ownership and Utility Index from RW-2 Plans (DD-301)
 _____ Completed Set of Soil Plans and Profiles Including Title Sheet (DD-402)

Cross Sections

_____ Complete Set of Mainline Cross Sections Showing Templates, Earthwork, Borings, RW Limits. Guardrail & Barriers
 _____ Complete Set of Sideroad Cross Sections Showing Templates, Earthwork, Borings, RW Limits. Guardrail & Barriers
 _____ All Drainage Features Shown
 _____ Quantity Tables Completed

**WEST VIRGINIA DIVISION OF HIGHWAYS
FINAL FIELD REVIEW SUBMISSION CERTIFICATION**

State Project No. _____

Consultant _____

Federal Project No. _____

Project Manager _____

Project Name _____

Submission Date _____

County _____

Final Field Review Report

- _____ Listing of Preliminary Field Review and Slope Review Comments and Action Taken on Each Comment
- _____ Preliminary Calculations for Turning Lane Lengths and Tapers, Intersection Sight Distances, Interchange Ramp Lengths
- _____ Completed Design Exception Reports
- _____ Completed ADA Exception Reports
- _____ Discussion of Construction Sequence Utilized in Plan Development
- _____ Listing of Proposed Project Specific Special Provisions
- _____ Discussion of Need for Incentive/Disincentive Contract Provisions (DD-708)

Miscellaneous Reports

- _____ Complete Drainage Calculations
- _____ Geometric Calculations
- _____ Geotechnical Report (Draft)
- _____ Total Project Construction Cost Estimate
- _____ Consultant's Quality Control Markups

Environmental Requirements

- _____ Type of 404 Permit Documented (Individual or Nationwide)
- _____ List of Required Environmental Mitigations (DD-206)
- _____ Certification and Listing of Adherence to Environmental Documents
- _____ Listing and Explanation of Deviations to Design Report and Env. Documents
- _____ Completed NPDES Registration Form
- _____ **MS4 Coordination with Municipality**

Value Engineering Report (If Applicable)

- _____ Listing of Comments From Value Engineering Review (DD-816)
- _____ Discussion of Actions Taken on Each Comment

Final Field Review Preparation

- _____ RW-2 Plans Submitted (DD-301)

- Notes:**
- 1- All Lines to be initialed by Office Manager or responsible management level above the Project Manager
 - 2- Use "NA" for any item not applicable to the project. Do not leave any items blank.

**WEST VIRGINIA DIVISION OF HIGHWAYS
FINAL OFFICE REVIEW SUBMISSION CERTIFICATION**

State Project No. _____
 Federal Project No. _____
 Project Name _____
 County _____

Consultant _____
 Project Manager _____
 Submission Date _____

General Plan Requirements

_____ Construction Project Numbers Shown
 _____ Line Weights Legible
 _____ Contours Screened and Legible
 _____ Adequate Spot Elevations Shown
 _____ All Phases of Work Included in a Bid Item

Plan and Profile Sheets

_____ Alignment, Curve Data, and Superlevation Shown for Mainline and all Sideroads
 _____ Stationing Shown for Mainline and all Sideroads
 _____ Grades and Vertical Curve Data, Including K-Value, Shown for Mainline and all Sideroads
 _____ Construction Limits Shown
 _____ Property Lines Shown
 _____ Disposition of all Crossroads, Railroads, and Streams or Rivers
 _____ Channel Change Requirements Incorporating Natural Channel Design Features Shown
 _____ All Drainage Requirements Including Pipes, Pipe Profiles, Ditches, and Underdrains Shown (DD-706)
 _____ Major Erosion and Sediment Control Features on Plans and Cross Sections
 _____ Drainage and Guardrail Limits/Data Noted on Plan and Profile Sheets
 _____ Proposed and Existing RW Limits Shown
 _____ Utility Dispositions Shown for all affected Utilities (If Available)
 _____ Existing Public & Private Utilities, Including Gas, Water, Septic, and Leach Fields for Residences, Shown (DD-303)
 _____ Pavement/Surface Limits for All Roads
 _____ Site Plans for All Structures
 _____ Curb Ramps and Other ADA Features

Typical Sections

_____ Mainline Typical
 _____ Sideroad Typical
 _____ Pavement Edge/Shoulder Details
 _____ Pavement Design with Legend Including all Related Details
 _____ Temporary Detour Typical

Miscellaneous Sheets

_____ Title Sheet with Proposed Sheet Index (DD-701)
 _____ Summary of Quantities Showing List of Items Separated by Categories with Alternates at the End of Each Category (BAMS Format) (DD-705)
 _____ General Note Sheets (DD-704)
 _____ Quantity Tables with all Quantities Completed (DD-705)
 _____ Mass Diagram
 _____ Reference Point Sheet
 _____ Geometric Layout Sheet with Coordinates
 _____ Benchmarks Shown on Ref. Pt. Sheet, Geometric Layout Sheet, or Profile Sheet
 _____ Superelevation Tables and Diagrams Completed for all Curves (DD-603)
 _____ Interchange Geometrics Shown
 _____ Intersection Layout Including Joint Layout
 _____ Complete Maintenance of Traffic Scheme Including Sequence of Construction (DD-681)
 _____ Traffic Routing Contingency Plan for Bridge/Structure Projects
 _____ Pavement Marking Layout (DD-682)
 _____ Sign Layout (DD-683)
 _____ Signal Layout
 _____ Lighting Layout (DD-684)
 _____ All Required Ret. Wall and Culvert Details Shown
 _____ Any Required Special Detail Sheets Including ADA Features
 _____ Property Maps, Ownership and Utility Index from Revised RW-3 Plans
 _____ Completed Set of Soil Plans and Profiles Including Title Sheet (DD-402)

Cross Sections

_____ Complete Set of Mainline Cross Sections Showing Templates, Earthwork, Borings, RW Limits. Guardrail & Barriers
 _____ Complete Set of Sideroad Cross Sections Showing Templates, Earthwork, Borings, RW Limits. Guardrail & Barriers
 _____ All Drainage Features Shown
 _____ Quantity Tables Completed

**WEST VIRGINIA DIVISION OF HIGHWAYS
FINAL OFFICE REVIEW SUBMISSION CERTIFICATION**

State Project No. _____
 Federal Project No. _____
 Project Name _____
 County _____

Consultant _____
 Project Manager _____
 Submission Date _____

Final Office Review Report

- _____ Listing of Final Field Review Comments and Action Taken on Each Comment
- _____ Final Calculations for Turning Lane Lengths and Tapers, Intersection Sight Distances, Interchange Ramp Lengths
- _____ Approved Design Exception Reports
- _____ Approved ADA Exception Reports
- _____ Discussion of Construction Sequence Utilized in Plan Development
- _____ Completed Copies of All Project Specific Special Provisions (Word Format) (DD-105, DD-820)
- _____ Complete Incentive/Disincentive Provisions
- _____ Letters Approving Proposed Relocations From Utility Companies

Environmental Requirements

- _____ List of Required Environmental Mitigations (DD-206)
- _____ Certification and Listing of Adherence to Environmental Documents
- _____ Listing and Explanation of Deviations to Design Report and Env. Documents
- _____ Copy of Transmittal Letter From DDT Submitting NPDES Registration to DEP
- _____ Completed NPDES Registration Form with all Attachments sent to DEP
- _____ **MS4 Coordination with Municipality**

Miscellaneous Reports

- _____ Complete Drainage Calculations
- _____ Computations Including Horizontal/Vertical Geometry and Quantity Calculations
- _____ Final Geotechnical Report (DD-402)
- _____ Consultant's Quality Control Markups

Corps of Engineers Permit Requirements

- _____ Plan View of all Project Areas Requiring a 404 Permit
- _____ Profile View of all Project Areas Requiring a 404 Permit
- _____ Cross Section View of all Project Areas Requiring a 404 Permit
- _____ Quantity of Material to be Placed Below "Ordinary High Water" Shown on Appropriate Sheets
- _____ Temporary Fills, Causeways, Bridges, Pipes, etc. Shown For Proposed Construction Scheme
- _____ Copy of Section 106 "Historical Clearance Document" Included
- _____ Copy of "Rare, Threatened, and Endangered Species Clearance Letter" Included
- _____ Copy of Letter Submitting Plans to Resource Agencies for Review
- _____ Copy of All Comments Received from Resource Agencies
- _____ Copy of FEMA Clearance Letter (If Applicable)
- _____ Two Copies of Completed 404 Permit Application Package Included

Supplemental Contract Information

- _____ Estimated Contract Time Chart (DD-803)
- _____ Total Project Construction Cost Estimate

Notes: 1- All Lines to be initialed by Office Manager or responsible management level above the Project Manager
 2- Use "NA" for any item not applicable to the project. Do not leave any items blank.

CONTRACT ADMINISTRATION DIVISION
REGIONAL CONSTRUCTION ENGINEERS

HANCOCK
BROOKE
OHIO
6
MARSHALL

DISTRICTS 4, 6
Michael Witherow, PE
Office:
Cell: 304-650-3041
Michael.Witherow@wv.gov

DISTRICTS 1, 2, 3
Jason Hamilton, PE
Office: 304-205-6208
Cell: 304-546-7871
Jason.G.Hamilton@wv.gov

WETZEL
MONONGALIA
TYLER
MARION
HARRISON
TAYLOR
DODDRIDGE
PRESTON

4
MINERAL
HAMPSHIRE
MORGAN
BERKELEY
JEFFERSON

WOOD
RITCHIE
WIRT
CALHOUN
JACKSON
ROANE
GILMER
LEWIS
UPSHUR
BARBOUR
TUCKER
GRANT
HARDY

DISTRICTS 5, 7, 8
Jason Tharp, PE
Office:
Cell: 304-989-2676
Jason.E.Tharp@wv.gov

7
BRAXTON
WEBSTER
POCAHONTAS

8
RANDOLPH
PENDLETON

MASON
PUTNAM
CABELL
WAYNE
LINCOLN
BOONE
MINGO
LOGAN
KANAWHA
1
2
3

CLAY
NICHOLAS
FAYETTE
GREENBRIER
RALEIGH
SUMMERS
MONROE
WYOMING
MERCER
MCDOWELL
9
10

DISTRICTS 9, 10
Matt Rowan, PE
Office: 304-558-9570
Cell: 304-590-3659
Matthew.L.Rowan@wv.gov



TECHNICAL SUPPORT DIVISION

404 NWP & NPDES

Travis Long – Director Technical Support Division

Travis.E.Long@wv.gov

304-414-6457

**Sondra Mullins – Assistant Director NEPA
Compliance**

Sondra.L.Mullins@wv.gov

304-414-6468

**All 404 NWP applications and questions shall be
submitted to: DOH404PermitRequest@wv.gov**

**All NPDES applications and questions shall be
submitted to: DOHNPDESPermitRequest@wv.gov**

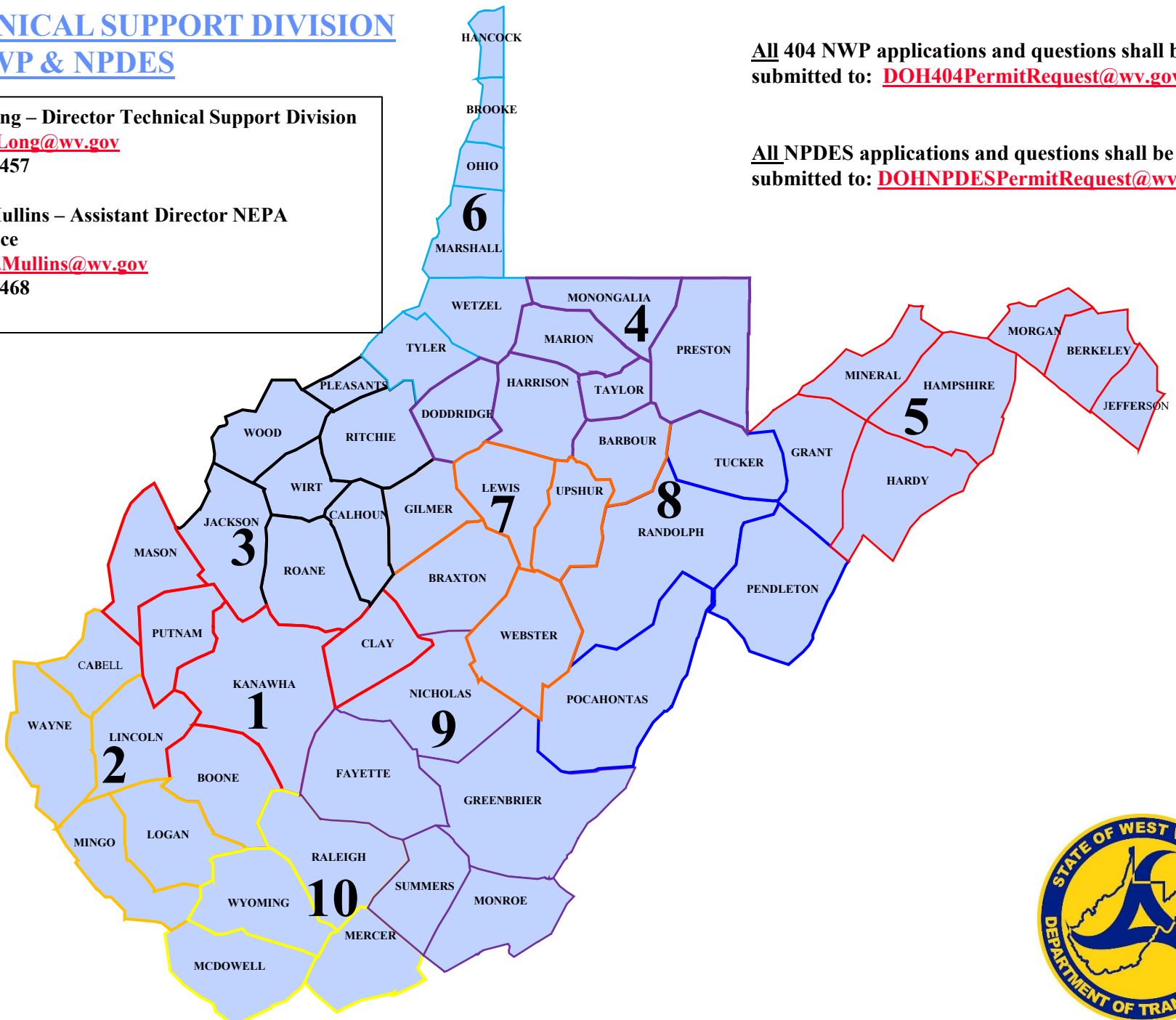

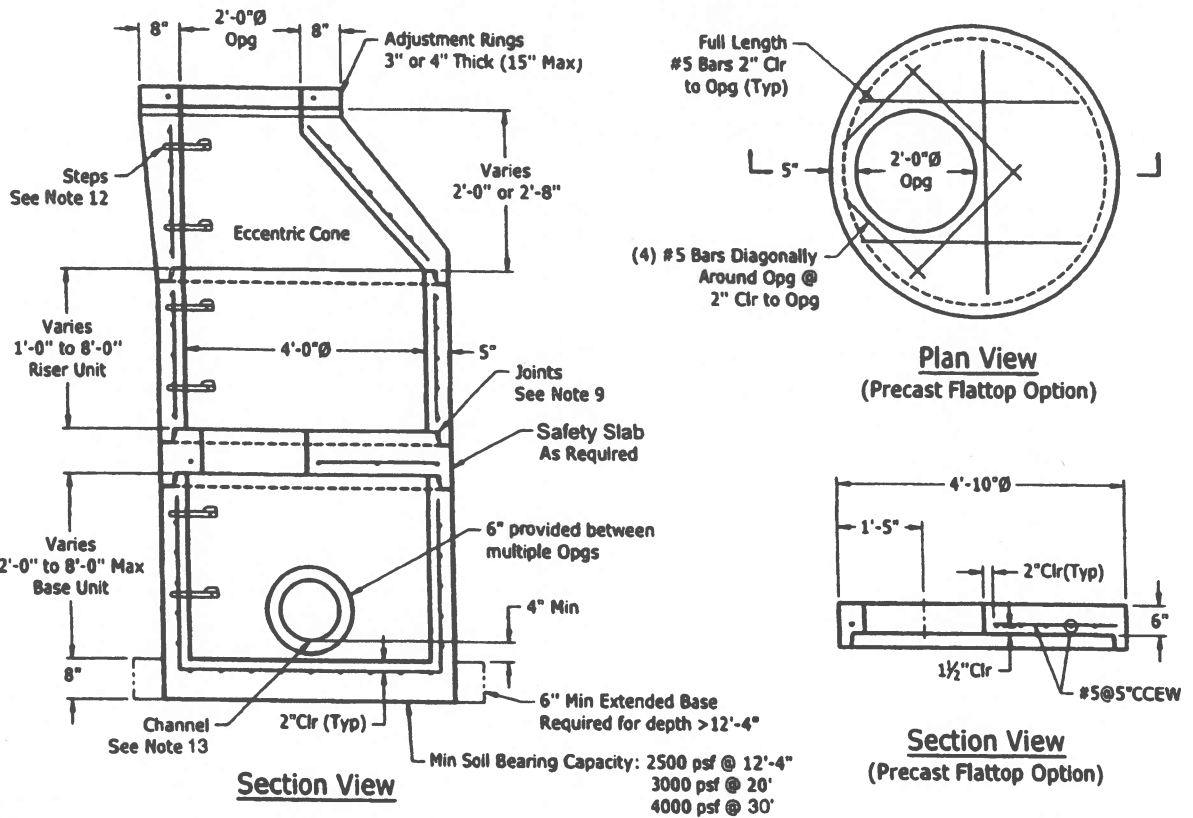

Notes:

- 1) This design is intended for precast structures produced by CP&P only.
- 2) Concrete to be 5,000 psi
- 3) Bar reinforcement conforms to ASTM A615 or A706, Grade 60 min. WWR reinforcement conforms to ASTM A1064, Grade 65 min.
- 4) Reinforcing: Walls: Min 0.12 in²/ft circumferential steel, Max Spacing 6".
Base: #4@10" OCEW (max) or WWR 4x4-W6.0xW6.0 to 20' depth; #4@8" OCEW (max) or WWR 4x4-W10.5xW10.5 to 37' depth.
- 5) Equivalent WWR may be used for rebar shown.
- 6) Manhole sections meet ASTM C478 / AASHTO M199.
- 7) Lifting devices provided for handling at manufacturer's discretion.
- 8) Grade and slope adjustments to be completed in the field by contractor.
- 9) Joints per manufacturer's design, sealed in field by contractor.
- 10) Pipe openings to be provided as required. For size, location, and invert elevations refer to construction plans.
- 11) Knockouts or holes for underdrain connections to be provided and located as directed on construction plans.
- 12) Step type to be M.A. Industries PS1-PF-DF at 16" spacing, aligned vertically.
- 13) Invert shaping to be constructed in the field by contractor, channel slopes at 2 in/ft, half depth of pipe. ⚠

WVDOT A MANHOLE
Precast 48" Ø Manhole for up to 24" Pipes

Dwg: WV-MH-48	Review Stamp	Seal for Precast Only
Orig Date: 3/27/24		
Last Rev: ---		

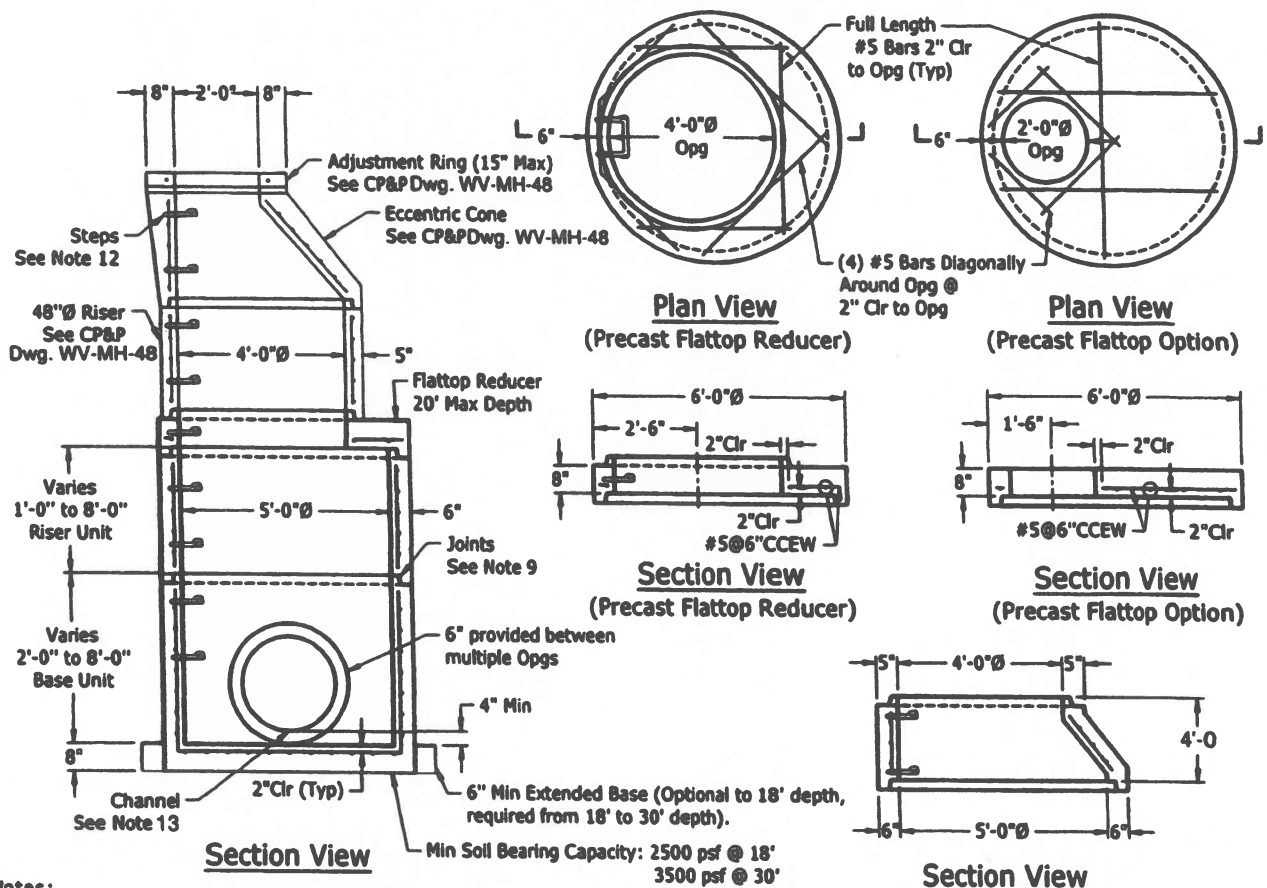

Notes:

- 1) This design is intended for precast structures produced by CP&P only.
- 2) Concrete to be 5,000 psi
- 3) Bar reinforcement conforms to ASTM A615 or A706, Grade 60 min. WWR reinforcement conforms to ASTM A1064, Grade 65 min.
- 4) Reinforcing: Walls: Min 0.15 in²/ft circumferential steel, Max Spacing 6".
 Base: #4@8" OCEW (max) or WWR 4x4-W10.5xW10.5 to 18' depth; #4@6" OCEW (max) or WWR 4x4-W10.5xW10.5 to 30' depth.
- 5) Equivalent WWR may be used for rebar shown.
- 6) Manhole sections meet ASTM C478 / AASHTO M199.
- 7) Lifting devices provided for handling at manufacturer's discretion.
- 8) Grade and slope adjustments to be completed in the field by contractor.
- 9) Joints per manufacturer's design, sealed in field by contractor.
- 10) Pipe openings to be provided as required. For size, location, and invert elevations refer to construction plans.
- 11) Knockouts or holes for underdrain connections to be provided and located as directed on construction plans.
- 12) Step type to be M.A. Industries PS1-PF-DF at 16" spacing, aligned vertically
- 13) Invert shaping to be constructed in the field by contractor, channel slopes at 2 in/ft, half depth of pipe.

VDOT A MANHOLE
Precast 60" Ø Manhole for up to 36" Pipes

Dwg: WV-MH-60	Review Stamp	Seal for Precast Only
Orig Date: 3/27/24		
Last Rev: ---		
<p align="center">Concrete Pipe & Precast, LLC 800.999.2278 10364 Design Road Ashland, VA 23005</p>		

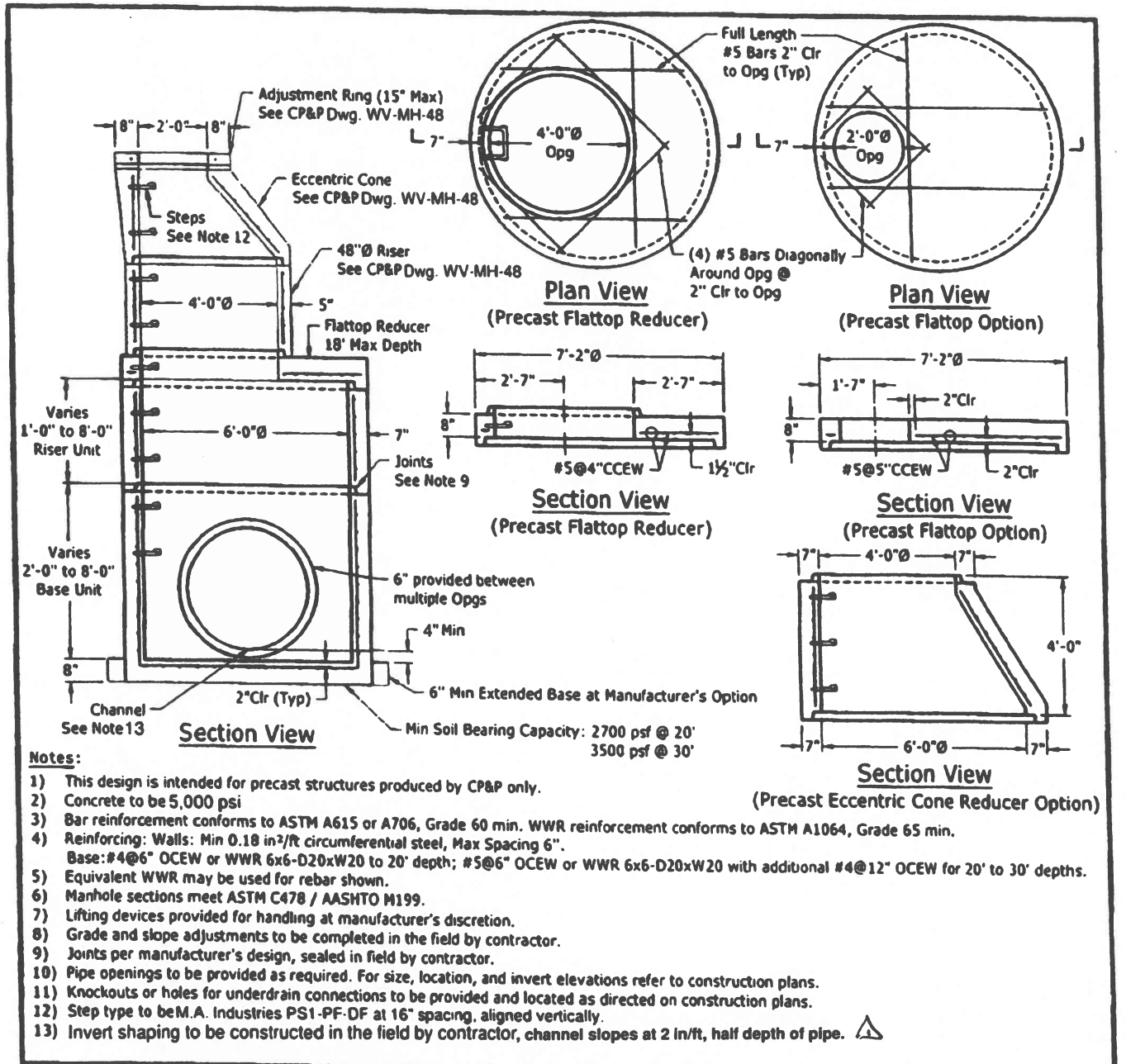

WVDOT A MANHOLE
Precast 72" Ø Manhole for up to 48" Pipes

Dwg:	WV-MH-72
Orig Date:	3/27/24
Last Rev:	---

Review Stamp

Seal for Precast Only

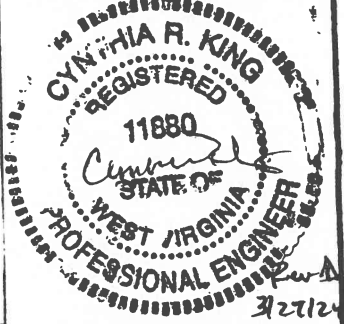
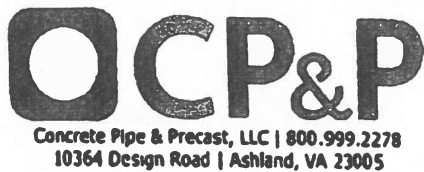

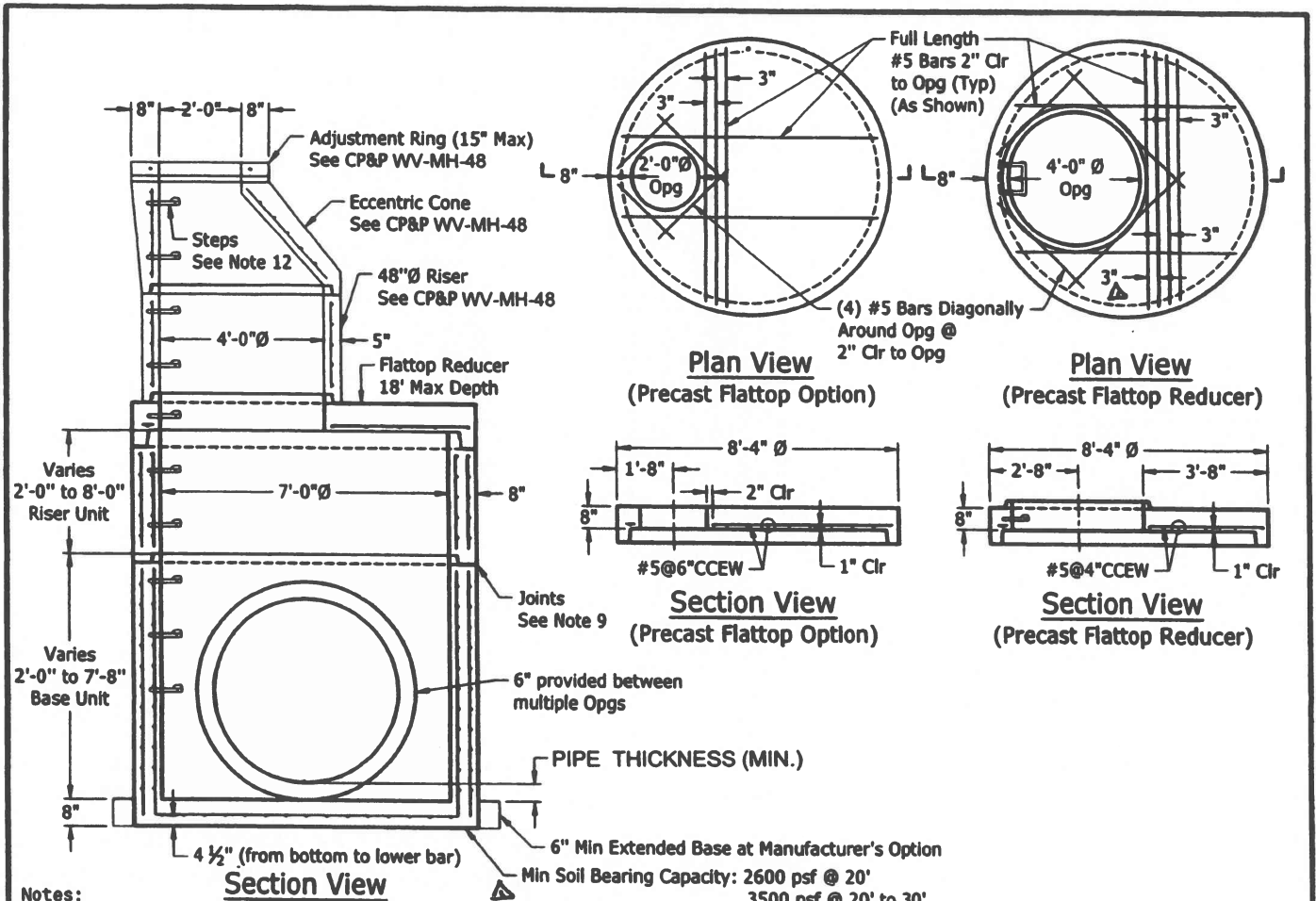

Notes:

- 1) This design is intended for precast structures produced by CP&P only.
- 2) Concrete to be 5000 PSI
- 3) Bar reinforcement conforms to ASTM A615 or A706, Grade 60 min. WWR reinforcement conforms to ASTM A1064, Grade 65 min.
- 4) Reinforcing: Walls: Min 0.21 in²/ft circumferential steel, Max Spacing 6".
Base: #5@6" OCEW for depths to 20' depth; #5@5" OCEW for 20' to 30' depths.
- 5) Equivalent WWR may be used for rebar shown.
- 6) Manhole sections meet ASTM C478 / AASHTO M199.
- 7) Lifting devices provided for handling at manufacturer's discretion.
- 8) Grade and slope adjustments to be completed in the field by contractor.
- 9) Joints per manufacturer's design, sealed in field by contractor.
- 10) Pipe openings to be provided as required. For size, location, and invert elevations refer to construction plans.
- 11) Knockouts or holes for underdrain connections to be provided and located as directed on construction plans.
- 12) Step type to be M.A. Industries PS1-PF-DF at 16" spacing, aligned vertically.
- 13) Invert shaping to be constructed in the field by contractor, channel slopes at 2 in/ft, half depth of pipe.

**VVDOT A MANHOLE
Precast 84" Ø Manhole for up to 60" Pipes**

Dwg: WV-MH-84	Review Stamp	Seal for Precast Only
Orig Date: 3/27/24		
Last Rev: ---		

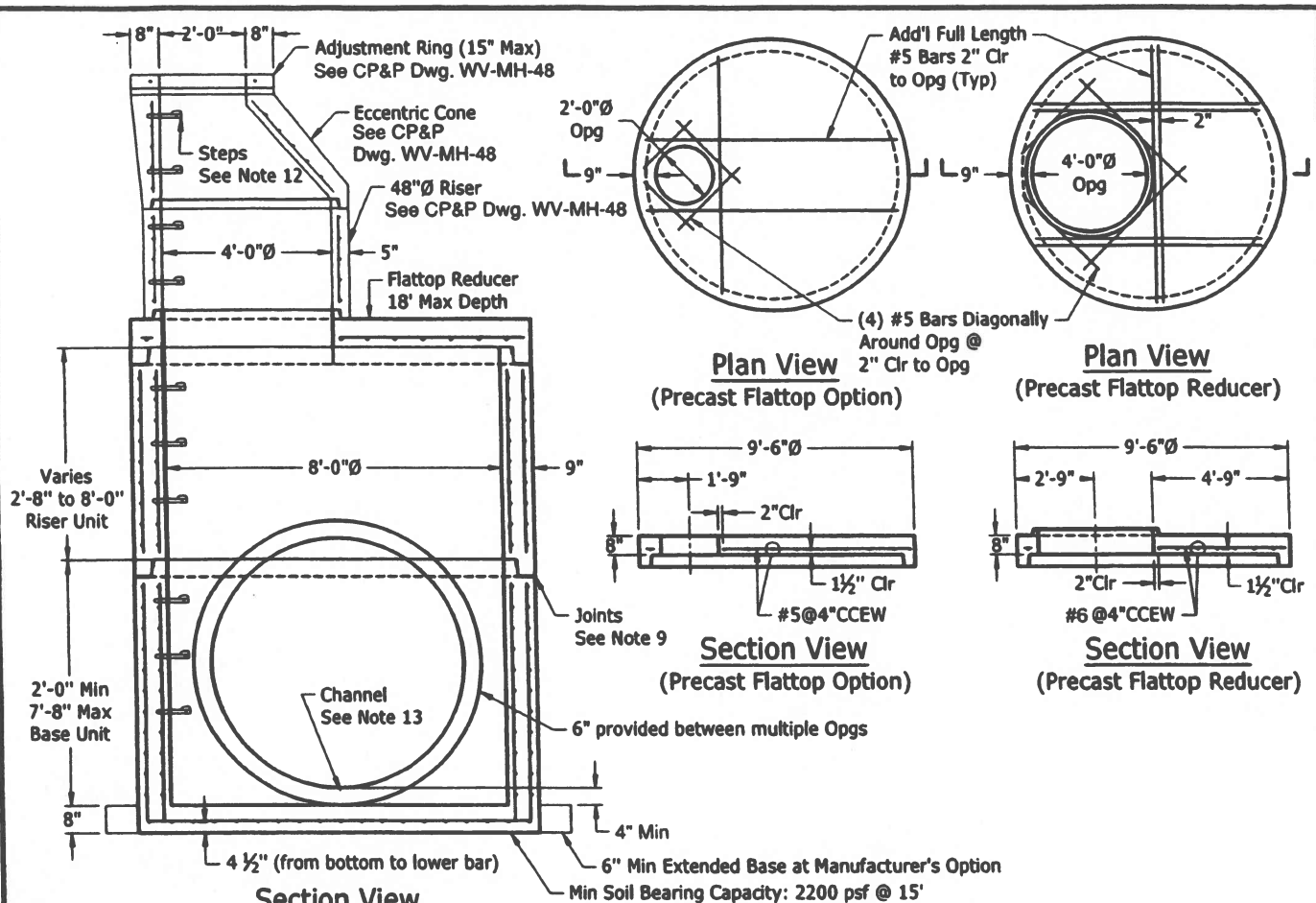

Notes:

- 1) This design is intended for precast structures produced by CP&P only.
- 2) Concrete to be 5,000 psi
- 3) Bar reinforcement conforms to ASTM A615 or A706, Grade 60 min. WWR reinforcement conforms to ASTM A1064, Grade 65 min.
- 4) Reinforcing: Walls: Min 0.24 in²/ft circumferential steel, Max Spacing 6".
Base: #5@5" OCEW or #6@7" OCEW to 15' depth; #5@3" OCEW or #6@5" OCEW for 15' to 30' depths.
- 5) Equivalent WWR may be used for rebar shown.
- 6) Manhole sections meet ASTM C478 / AASHTO M199.
- 7) Lifting devices provided for handling at manufacturer's discretion.
- 8) Grade and slope adjustments to be completed in the field by contractor.
- 9) Joints per manufacturer's design, sealed in field by contractor.
- 10) Pipe openings to be provided as required. For size, location, and invert elevations refer to construction plans.
- 11) Knockouts or holes for underdrain connections to be provided and located as directed on construction plans.
- 12) Step type to be M.A. Industries PS1-PF-DF at 16" spacing, aligned vertically.
- 13) Invert shaping to be constructed in the field by contractor, channel slopes at 2 in/ft, half depth of pipe. Δ

**VVDOT A MANHOLE
Precast 96" Ø Manhole for up to 72" Pipes**

Dwg: WV-MH-96	Review Stamp	Seal for Precast Only
Orig Date: 3/27/24		
Last Rev: ---		
UID:		

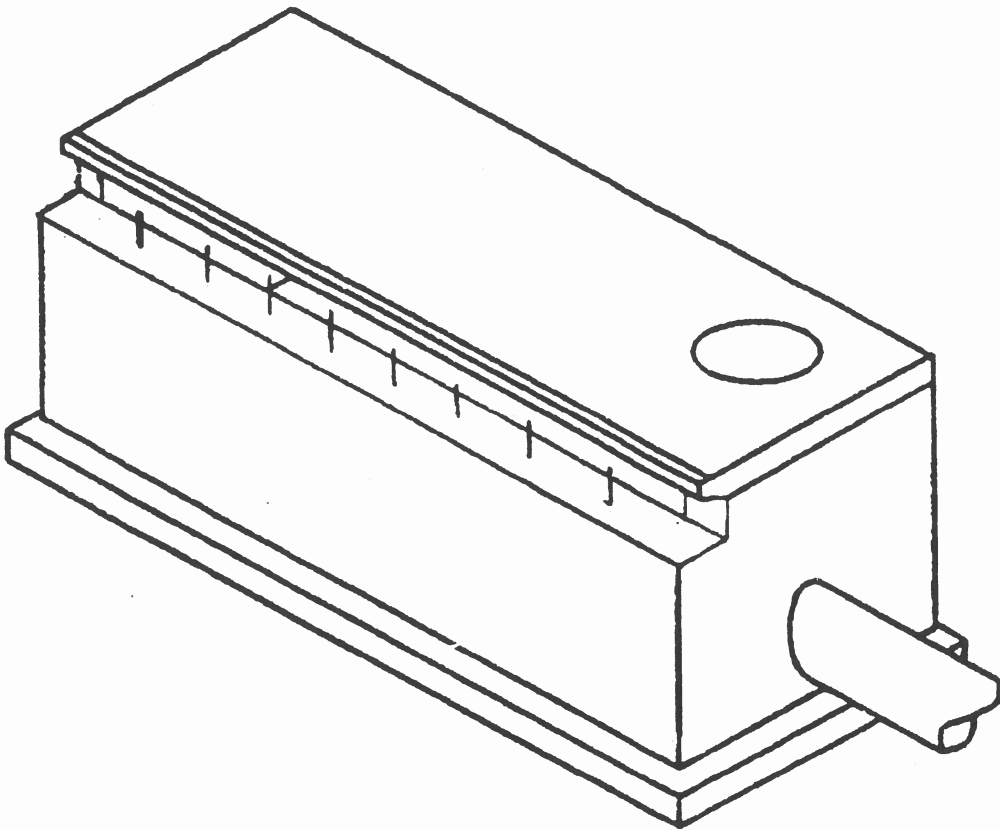

Notes:

1. Minimum Concrete Compressive Strength to be 5000 psi.
2. Rebar to be ASTM A706 or A615, Grade 60.
3. Steps provided when height is 4'-0" or greater.
4. Gutter Pan/ Throat Face to be poured in field by others.
5. Out pipe has a 4" minimum sump.
6. Invert shaping to be constructed in field by contractor, channel slope at 2 in/ft. half depth of pipe.

WEST VIRGINIA D.O.T. REF DR6-D
 WEST VIRGINIA D.O.T. REF DR6-E

WVDOT TYPE D / E INLET (SHALLOW)

PAGE 1 OF 6

Dwg: WVDOT SHALLOW D / E INLET	Review Stamp	Seal for Precast Only
Orig Date: 3/27/24		
Last Rev:		
UID:		
 Concrete Pipe & Precast, LLC 800.999.2278 10364 Design Road Ashland, VA 23005		

#m BARS c' b' o.c.
LENGTH = W + 14"

1'-0" L + 6 1/2" 1'-0" #'n' e
'a' o.c. (TYP.)

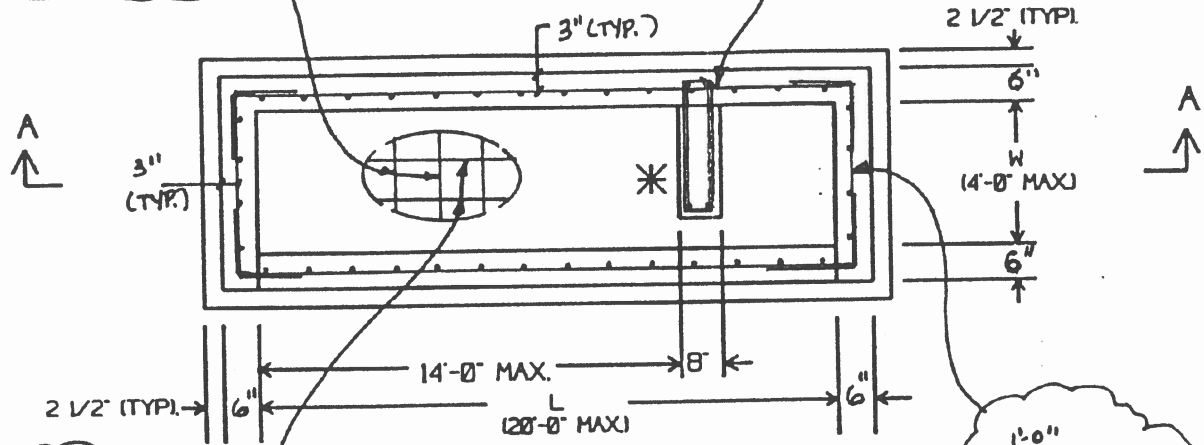

#m BARS c' b' o.c.
LENGTH = L + 14"

1'-0" W + 6 1/2" 1'-0" #'n' e 'a' o.c. (TYP.)

PLAN
(TOP SLAB REMOVED)
SEE SECTION VIEWS FOR
VERTICAL REINFORCEMENT

* CENTER WALL TO BE USED WHEN
THROAT LENGTH EXCEEDS 14'-0".
(SEE SEC. C-C).

BAR SPACING				
L	Horiz.		Base	
	n	a	m	b
>16'	5	6"	4	12"
>12'	5	9"	4	12"
>8'	4	9"	4	16"
≤8'	4	14"	4	16"

WEST VIRGINIA D.O.T. REF DR6-D
WEST VIRGINIA D.O.T. REF DR6-E

WVDOT TYPE D / E INLET (SHALLOW)

Dwg: WVDOT SHALLOW D / E INLET
Orig Date: 3/27/24
Last Rev:
UID:

Review Stamp

Seal for Precast Only



Concrete Pipe & Precast, LLC | 800.999.2278
10364 Design Road | Ashland, VA 23005

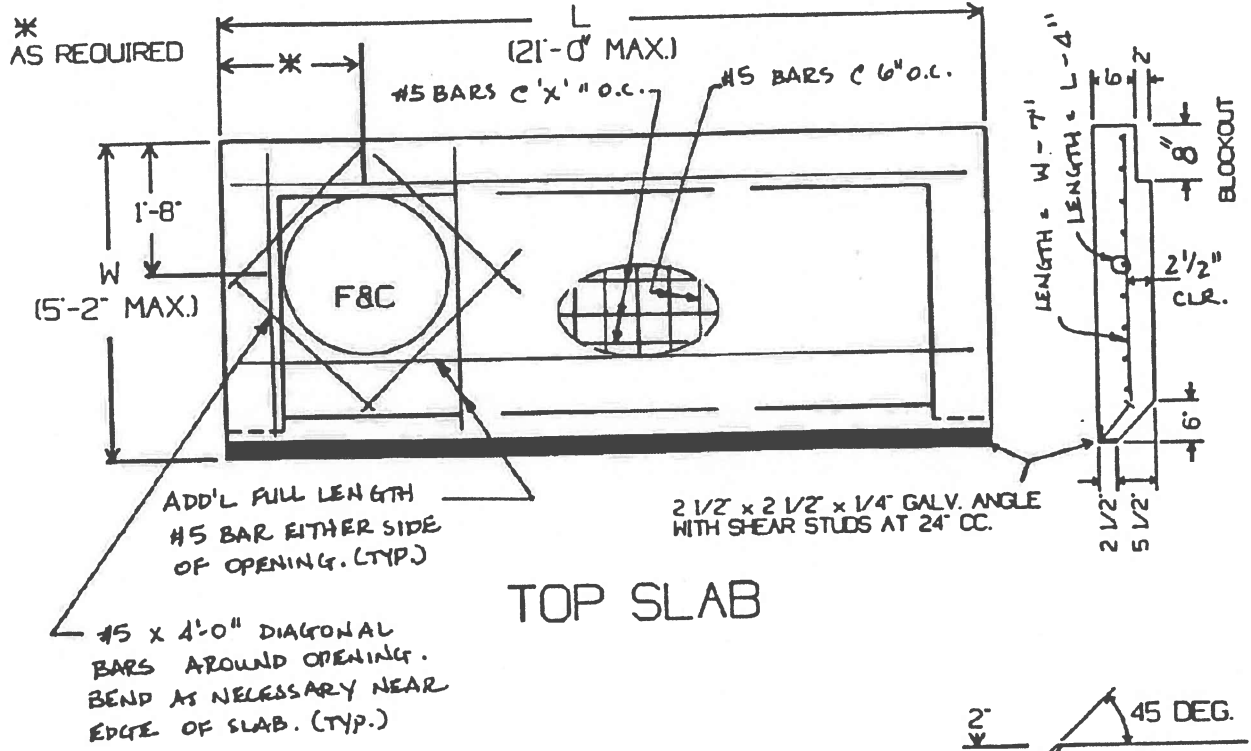

LONGITUDINAL SPACING	
L (ft.)	X (in.)
> 11'	4"
> 8'	6"
> 7'	8"
≤ 7'	10"

WEST VIRGINIA D.O.T. REF DR6-D
WEST VIRGINIA D.O.T. REF DR6-E

WVDOT TYPE D / E INLET (SHALLOW)

Dwg: WVDOT SHALLOW D / E INLET
Orig Date: 3/27/24
Last Rev:
UID:

Review Stamp

Seal for Precast Only



Concrete Pipe & Precast, LLC | 800.999.2278
10364 Design Road | Ashland, VA 23005

$(H - 8" + B/2)$
 1'-0"
 #4 BAR
 USE SAME
 SPACING AS
 BASE SLAB
 BARS

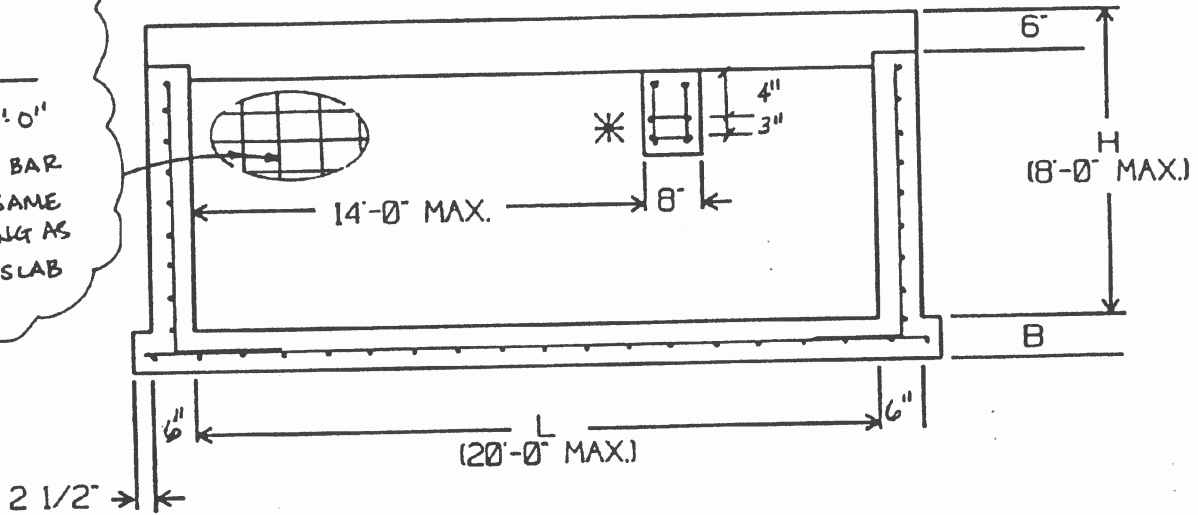

SEC A-A

NOTE: PLACE ADD'L VERT. & HOR. BARS
 ON EITHER SIDE OF OPENINGS.
 PLACE (2) #5 DIAGONALS AROUND
 OPENING, BENDING AS NECESSARY
 NEAR WALL EDGES. DIAGONAL
 LENGTH TO BE OPENING SIZE
 + 24".

* CENTER WALL TO BE USED WHEN
 THROAT LENGTH EXCEEDS 14'-0".
 (SEE SEC. C-C).

SLAB THICKNESS		
H	L	B
> 7'	> 14'	8"
> 7'	≤ 14'	6"
≤ 7'	≤ L _{max}	6"

WEST VIRGINIA D.O.T. REF DR6-D
 WEST VIRGINIA D.O.T. REF DR6-E

WVDOT TYPE D / E INLET (SHALLOW)

Dwg: WVDOT SHALLOW D / E INLET Orig Date: 3/27/24 Last Rev: UID:	Review Stamp	Seal for Precast Only
 Concrete Pipe & Precast, LLC 800.999.2278 10364 Design Road Ashland, VA 23005		

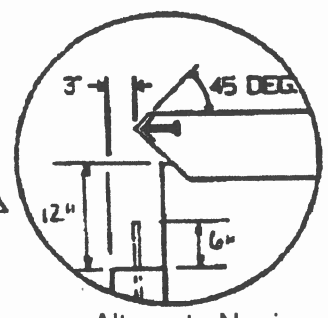
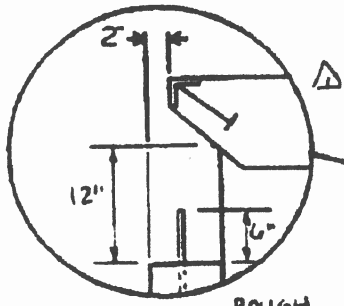

Alternate Nosing
4" Curb Height

ROUGH
FINISH

(H-12" D/2)
1'-0"
#4 BARS
USE SAME
SPACING AS
BASE SLAB
BARS

2 1/2"
(TYP.)

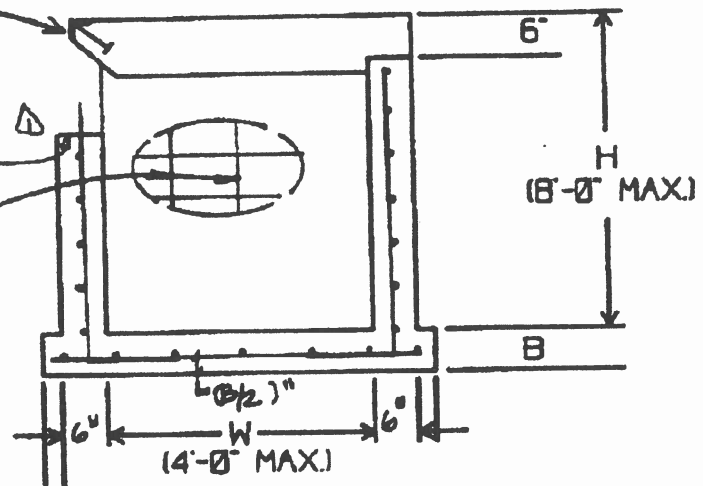

SEC B-B

WEST VIRGINIA D.O.T. REF DR6-D
WEST VIRGINIA D.O.T. REF DR6-E

WVDOT TYPE D / E INLET (SHALLOW)

Dwg: WVDOT SHALLOW D / E INLET
Orig Date: 3/27/24
Last Rev:
UID:

Review Stamp

Seal for Precast Only

OCP&P
 Concrete Pipe & Precast, LLC | 800.999.2278
 10364 Design Road | Ashland, VA 23005

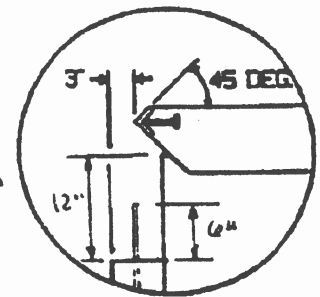
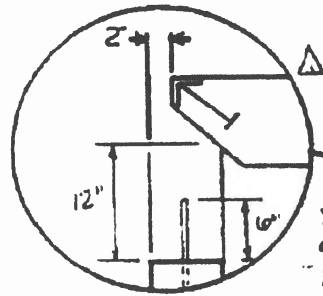

Alternate Nosing
4" Curb Height

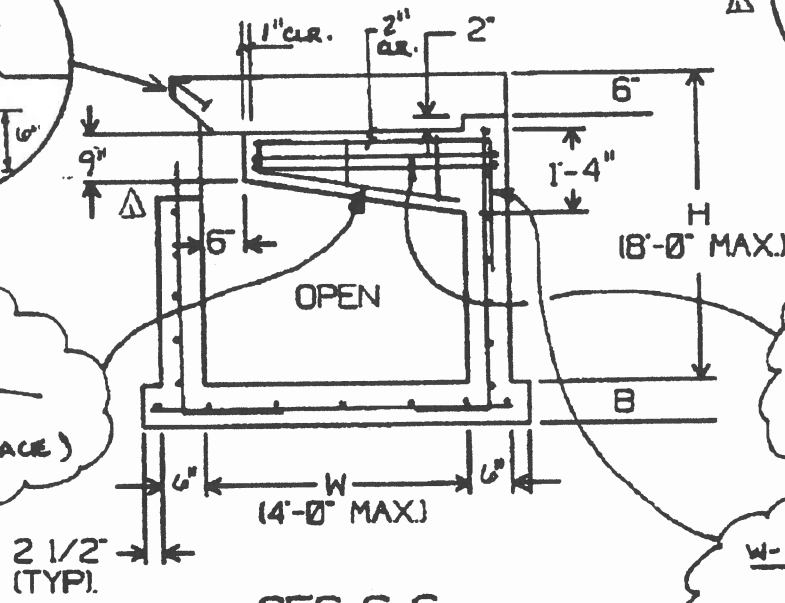
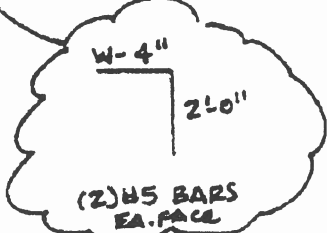
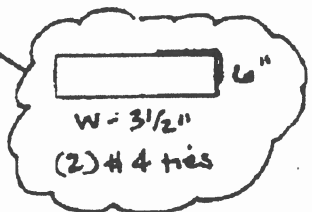
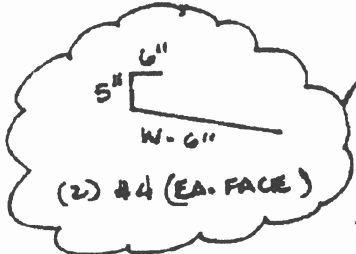

SEC C-C
CENTER WALL TO BE USED
WHEN THROAT LENGTH
EXCEEDS 14'-0".

WEST VIRGINIA D.O.T. REF DR6-D
WEST VIRGINIA D.O.T. REF DR6-E

WVDOT TYPE D / E INLET (SHALLOW)

Dwg: WVDOT SHALLOW D / E INLET
Orig Date: 3/27/24
Last Rev:
UID:

Review Stamp

Seal for Precast Only



Concrete Pipe & Precast, LLC | 800.999.2278
10364 Design Road | Ashland, VA 23005

PIPE OPN'G
AS REQUIRED
(24" MAX)

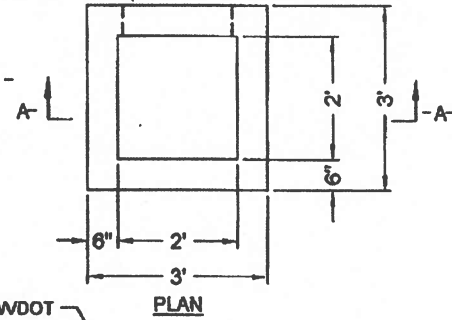

STANDARD WVDOT
"B" INLET F&G
(SET ON TOP)
SEE WV STANDARD
SHEET DR6-B

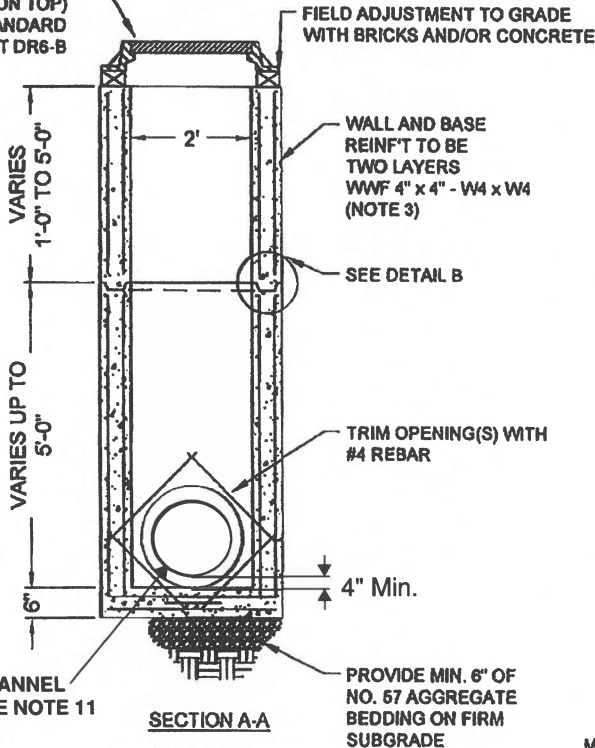

CHANNEL
SEE NOTE 11

SECTION A-A

PROVIDE MIN. 6" OF
NO. 57 AGGREGATE
BEDDING ON FIRM
SUBGRADE

NOTES:

1. INLET TO BE CONSTRUCTED IN ACCORDANCE WITH ASTM C 913.
2. CONCRETE MIX TO BE 5,000 PSI AT 28 DAYS MIN, TYPE II PORTLAND CEMENT.
3. REINFORCING DEFORMED BARS SHALL BE ASTM A-616, GR. 80, AND WELDED WIRE FABRIC REINFORCING IN ACCORDANCE WITH ASTM A185 & A82 GRADE 65. REINFORCING STEEL SHALL HAVE 1 1/2" CONCRETE COVER EACH FACE.
4. LIFT HOLES OR LIFT EYES PROVIDED IN EACH SECTION FOR HANDLING ARE TO BE FILLED WITH AN APPROVED NON-SHRINK GROUT OR CONCRETE BY CONTRACTOR AS SPECIFIED (IF APPLICABLE).
5. TRIM ALL OPNE'S IN BASE, WALLS, AND T/S WITH#4 DEFORMED BAR, UNLESS NOTED.
6. ANNULAR SPACE BETWEEN PIPE AND HOLE TO BE FILLED WITH AN APPROVED NON-SHRINK GROUT OR CONCRETE BY CONTRACTOR AS REQUIRED.
7. PROVIDE BENT CONTINUOUS WWF OR BAR AT WALL CORNERS TO PROVIDE CONTINUOUS HORIZONTAL REINFORCING. BAR LAPS 16 INCHES MINIMUM.
8. THE JOINTS ARE TO BE GROUETO WITH NON-SHRINK GROUT AND/OR MORTAR, INSIDE AND OUT, AND SEALED BY THE CONTRACTOR TO A WATERTIGHT SEAL. SEAL TO BE ACHIEVED USING NON-SHRINK GROUT, MORTAR, RUBBER GASKETS, ANDIOR BITUMINOUS MASTIC AS REQUIRED 8Y CONTRACT DRAWINGS. RUBBER GASKET SEAL MEETS AASHTO M 188 TYPE B OR ASTM C 361 & ASTM C 443.
9. STANDARD PRECAST MANHOLE(S) ARE DESIGNED FOR LATERAL EARTH PRESSURES IN EXCESS OF 50 FEET OF VERTICAL DEPTH.
10. WEEP HOLES AS REQUIRED.
11. INVERT SHAPING TO BE CONSTRUCTED IN THE FIELD BY CONTRACTOR, CHANNEL SLOPES AT 2 IN/FT, HALF DEPTH OF PIPE.

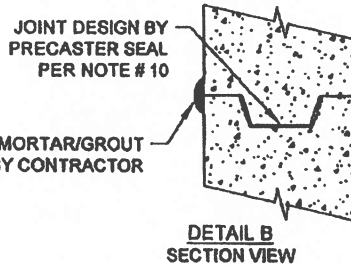

DETAIL B
SECTION VIEW

WEST VIRGINIA D.O.T. REF DR8-B

**"B" INLET 24"x24" (2'x2')
SQUARE INLET**

Dwg: "B" INLET 24X24 - WVDOT	Review Stamp	Seal for Precast Only
Orig Date: 3/27/24		
Last Rev:		
UID: BI-24X24		

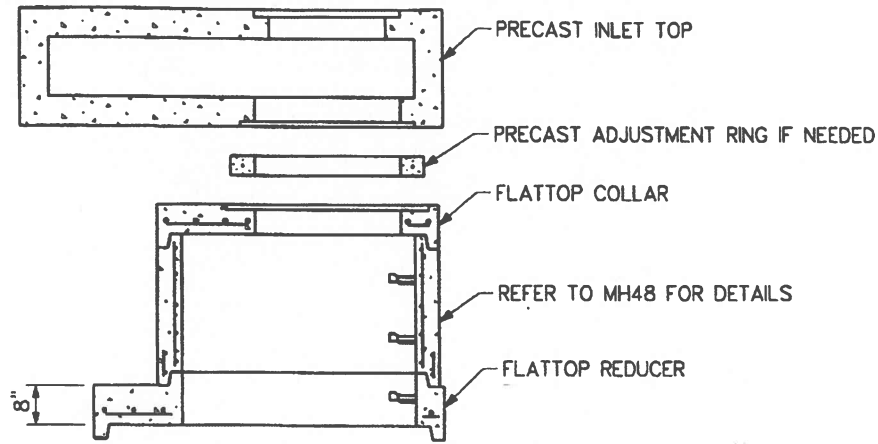

ALT. REDUCING METHOD DETAIL

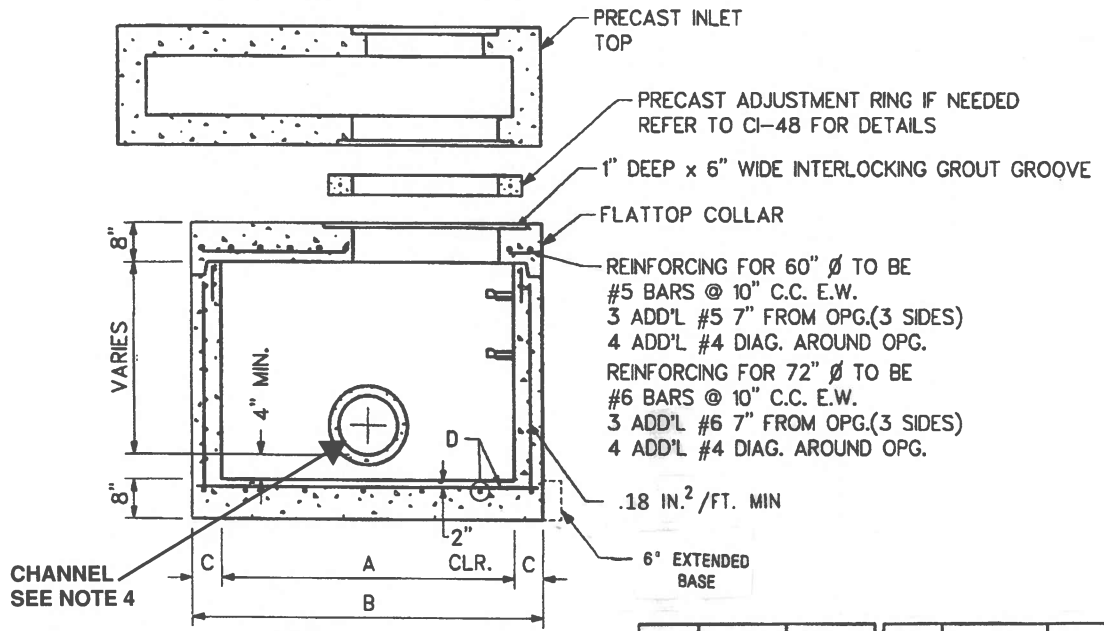

SECTION VIEW

DIM	CI-60	CI-72	DIM	CI-60	CI-72
"A"	60"	72"	"D"	#5 @ 12" C.C. E.W.	#6 @ 12" C.C. E.W.
"B"	72"	86"			
"C"	6"	7"			

Notes:

1. Minimum Concrete Compressive Strength to be 5000 psi.
2. Rebar to be ASTM A706 or A615, Grade 60.
Welded Wire Reinforcement to be ASTM A1064, Grade 65.
3. Dowel Holes provided to prevent settlement of adjacent concrete.
4. Invert shaping to be constructed in field by contractor, channel slope at 2 in/ft. half depth of pipe.

WVDOT TYPE D / E INLET

WEST VIRGINIA D.O.T. DWG REF DR6-E

Dwg: WVDOT E-INLET	Review Stamp	Seal for Precast Only
Orig Date: 3/27/24		
Last Rev:		
UID:		
 <p>Concrete Pipe & Precast, LLC 800.999.2278 10364 Design Road Ashland, VA 23005</p>		

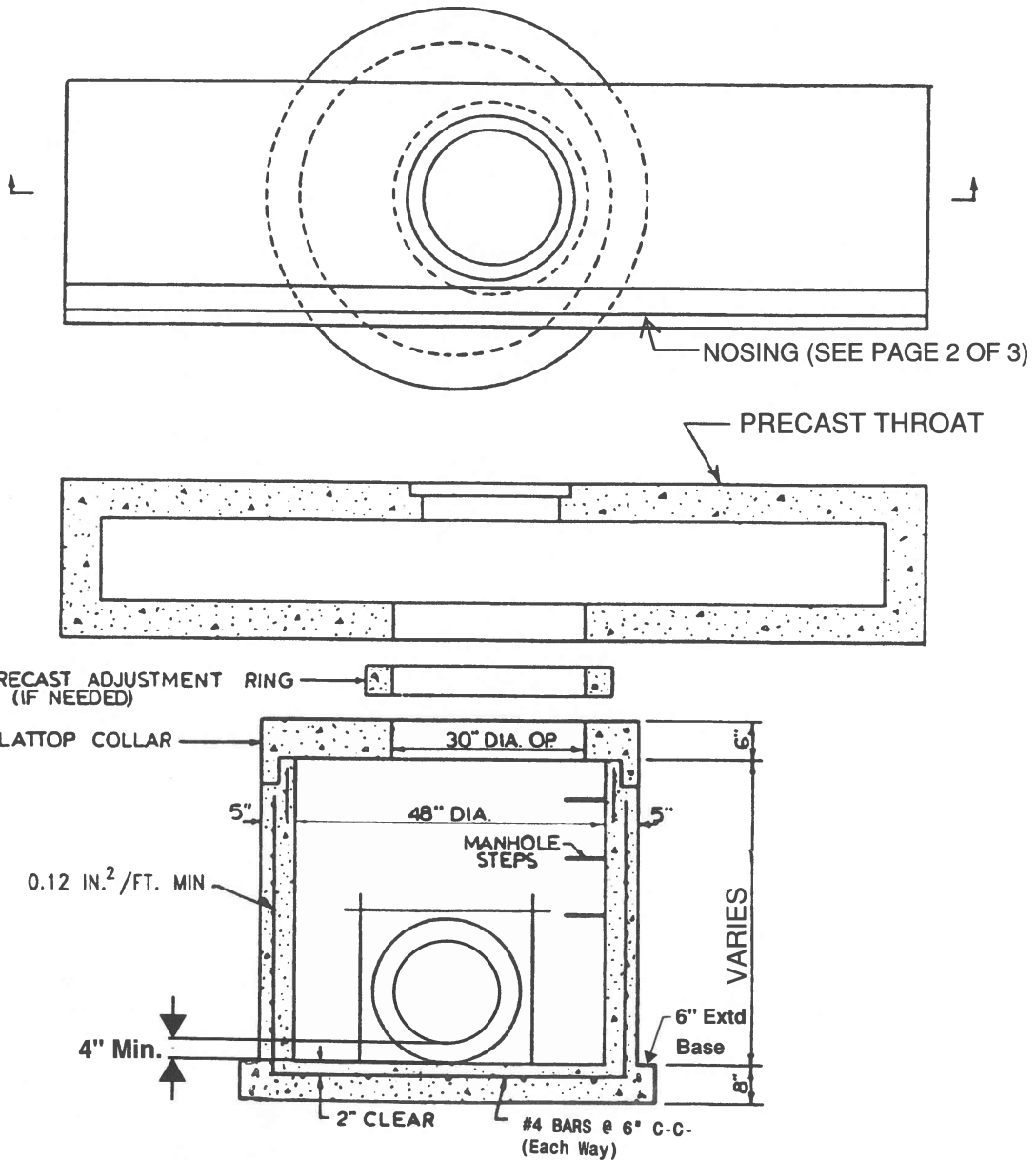

Notes:

1. Minimum Concrete Compressive Strength to be 5000 psi.
2. Rebar to be ASTM A706 or A615, Grade 60.
Welded Wire Reinforcement to be ASTM A1064, Grade 65.
3. Dowel Holes provided to prevent settlement of adjacent concrete.
4. Invert shaping to be constructed in field by contractor, channel slope at 2 in/ft. half depth of pipe.

WEST VIRGINIA D.O.T. REF DR6-D
WEST VIRGINIA D.O.T. REF DR6-E

WVDOT TYPE D / E INLET

PAGE 1 OF 3

Dwg: WVDOT D / E INLET	Review Stamp	Seal for Precast Only
Orig Date: 3/27/24		
Last Rev:		
UID:		
<div style="display: flex; align-items: center;">  <p>Concrete Pipe & Precast, LLC 800.999.2278 10364 Design Road Ashland, VA 23005</p> </div>		

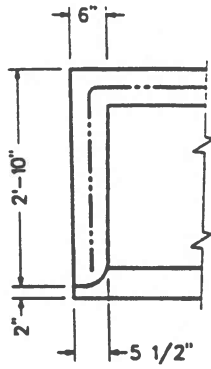

END WALL DETAIL

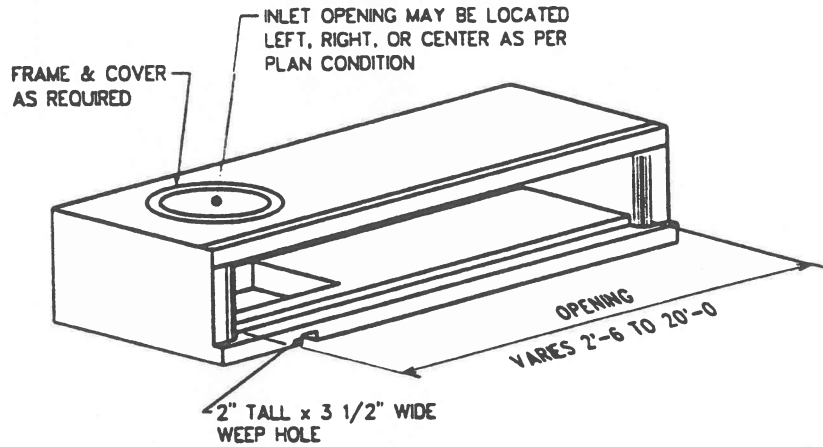

PERSPECTIVE VIEW

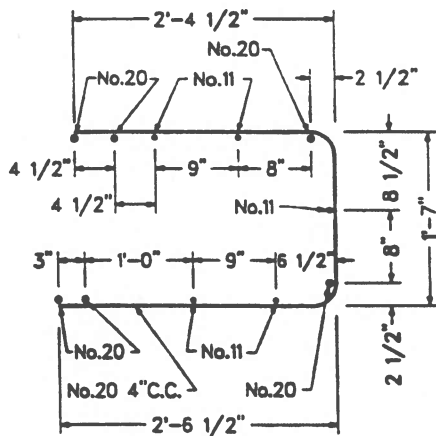

REINFORCEMENT DETAIL
WELDED WIRE FABRIC

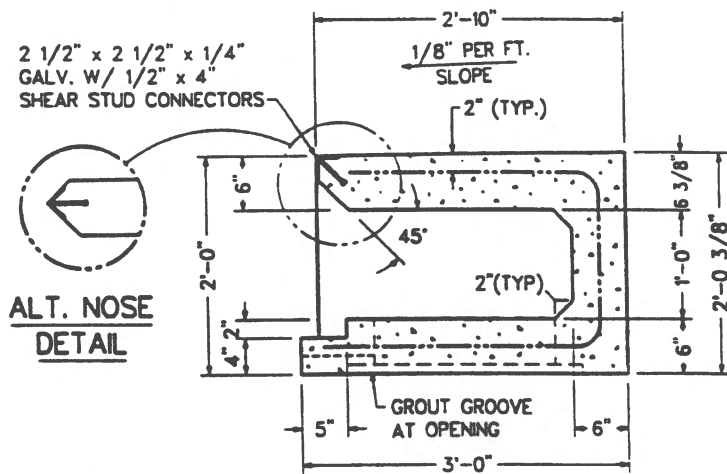

SECTION VIEW

Notes:

1. Minimum Concrete Compressive Strength to be 5000 psi.
2. Rebar to be ASTM A706 or A615, Grade 60.
Welded Wire Reinforcement to be ASTM A1064, Grade 65.
3. Dowel Holes provided to prevent settlement of adjacent concrete.
4. Invert shaping to be constructed in field by contractor, channel slope at 2 in/ft. half depth of pipe.

WEST VIRGINIA D.O.T. REF DR6-D
WEST VIRGINIA D.O.T. REF DR6-E

WVDOT TYPE D / E INLET

PAGE 2 OF 3
THROAT SECTION

Dwg: **WVDOT D / E INLET**

Review Stamp

Seal for Precast Only

Orig Date: **3/27/24**

Last Rev:

UID:



Concrete Pipe & Precast, LLC | 800.999.2278
10364 Design Road | Ashland, VA 23005

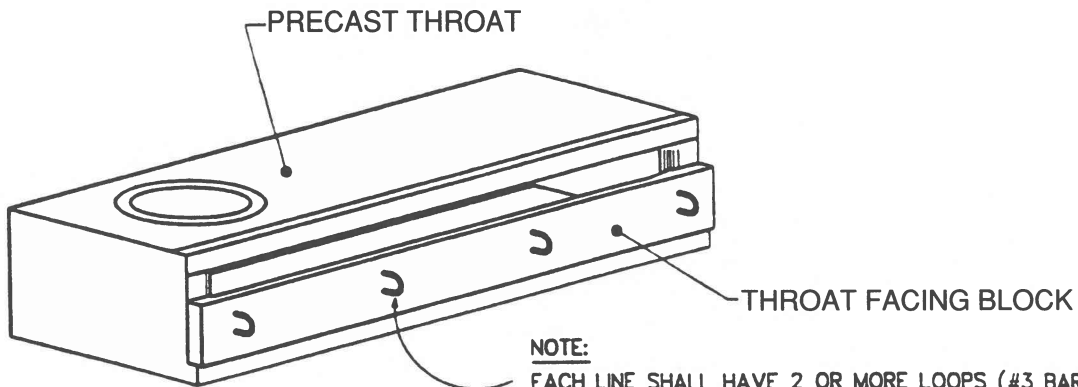

PERSPECTIVE VIEW

NOTE:
 EACH LINE SHALL HAVE 2 OR MORE LOOPS (#3 BAR)
 CAST IN FACE AS SHOWN. THESE LOOPS MAY BE USED
 FOR LIFTING, AND FOR TYING IN THE POURED IN PLACE
 GUTTER SECTION.

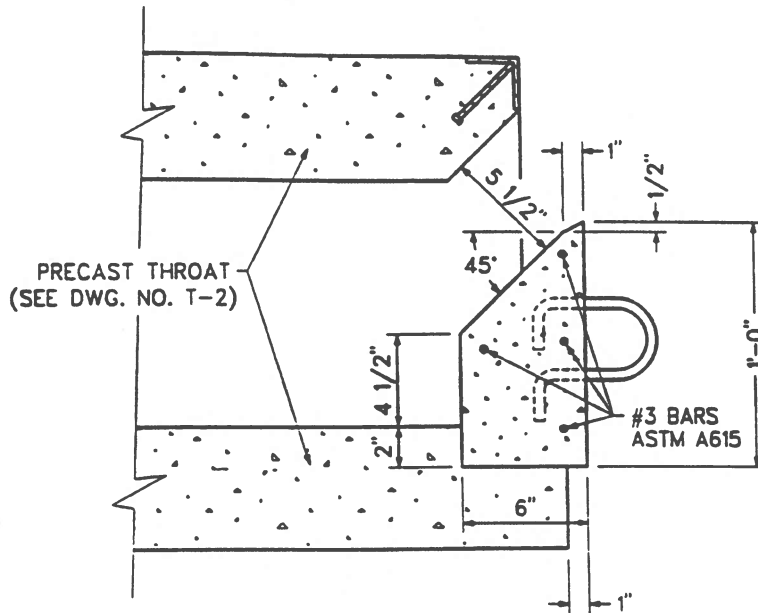

SECTION VIEW

Notes:

1. Minimum Concrete Compressive Strength to be 5000 psi.
2. Rebar to be ASTM A706 or A615, Grade 60.
 Welded Wire Reinforcement to be ASTM A1064, Grade 65.
3. Dowel Holes provided to prevent settlement of adjacent concrete.
4. Invert shaping to be constructed in field by contractor, channel slope at 2 in/ft. half depth of pipe.

WEST VIRGINIA D.O.T. REF DR6-D
 WEST VIRGINIA D.O.T. REF DR6-E

WVDOT TYPE D / E INLET

PAGE 3 OF 3
 THROAT FACING BLOCK

Dwg: **WVDOT D / E INLET**

Review Stamp

Seal for Precast Only

Orig Date: **3/27/24**

Last Rev:

UID:



Concrete Pipe & Precast, LLC | 800.999.2278
 10364 Design Road | Ashland, VA 23005

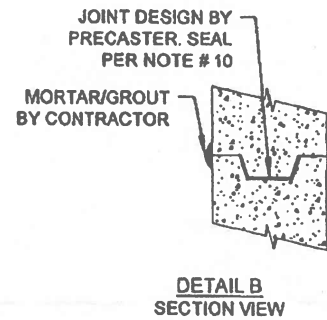
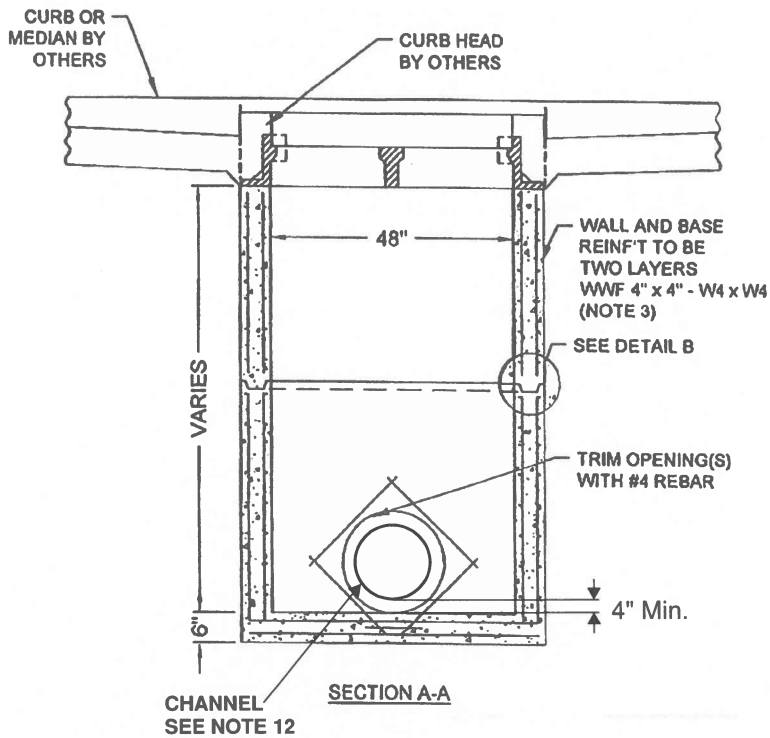
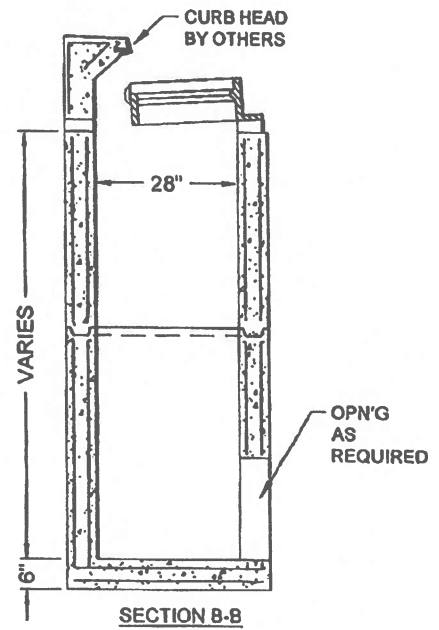
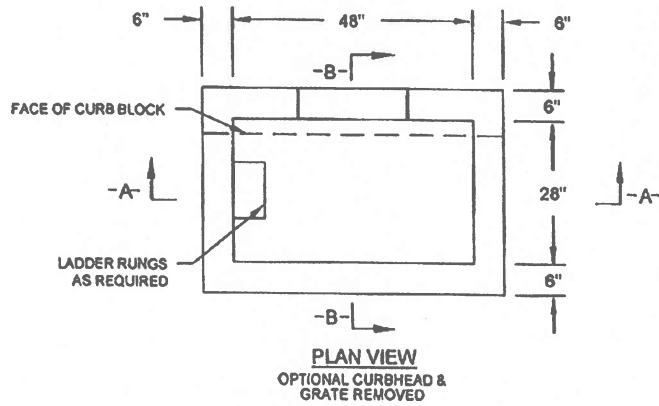

WEST VIRGINIA D.O.T. REF DR6-F

"F" INLET

PAGE 1 OF 2

Dwg: F- INLET WVDOT

Review Stamp

Seal for Precast Only

Orig Date: 3/27/24

Last Rev:

UID: F- INLET

OCP&P

Concrete Pipe & Precast, LLC | 800.999.2278
10364 Design Road | Ashland, VA 23005

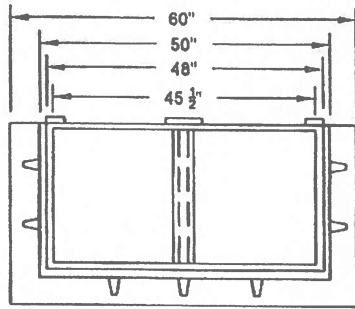

PLAN

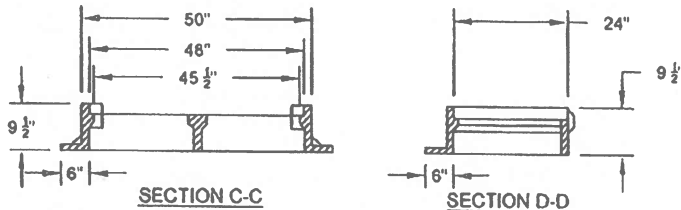

SECTION C-C

SECTION D-D

NOTES:

1. INLET TO BE CONSTRUCTED IN ACCORDANCE WITH ASTM C 913.
2. CONCRETE MIX TO BE 5,000 PSI AT 28 DAYS MIN, TYPE II PORTLAND CEMENT.
3. REINFORCING DEFORMED BARS SHALL BE ASTM A-616, GR. 80, AND WELDED WIRE FABRIC REINFORCING IN ACCORDANCE WITH ASTM A185 & A82 GRADE 65. REINFORCING STEEL SHALL HAVE 1 1/2" CONCRETE COVER EACH FACE.
4. LADDER RUNGS INSTALLED IN VERTICAL ALIGNMENT DESIGNED TO PREVENT LATERAL SLIPPAGE, 1'-0" C/C MAX.
5. LIFT HOLES OR LIFT EYES PROVIDED IN EACH SECTION FOR HANDLING ARE TO BE FILLED WITH AN APPROVED NON-SHRINK GROUT OR CONCRETE BY CONTRACTOR AS SPECIFIED (IF APPLICABLE).
6. TRIM ALL OPNE'S IN BASE, WALLS, AND T/S WITH#4 DEFORMED BAR, UNLESS NOTED.
7. ANNULAR SPACE BETWEEN PIPE AND HOLE TO BE FILLED WITH AN APPROVED NON-SHRINK GROUT OR CONCRETE BY CONTRACTOR AS REQUIRED.
8. PROVIDE BENT CONTINUOUS WWF OR BAR AT WALL CORNERS TO PROVIDE CONTINUOUS HORIZONTAL REINFORCING. BAR LAPS 16 INCHES MINIMUM.
9. THE JOINTS ARE TO BE GROUTEO WITH NON-SHRINK GROUT AND/OR MORTAR, INSIDE AND OUT, AND SEALED BY THE CONTRACTOR TO A WATERTIGHT SEAL. SEAL TO BE ACHIEVED USING NON-SHRINK GROUT, MORTAR, RUBBER GASKETS, ANDIOR BITUMINOUS MASTIC AS REQUIRED 8Y CONTRACT DRAWINGS. RUBBER GASKET SEAL MEETS AASHTO M 188 TYPE B OR ASTM C 361 & ASTM C 443.
10. STANDARD PRECAST MANHOLE(S) ARE DESIGNED FOR LATERAL EARTH PRESSURES IN EXCESS OF 50 FEET OF VERTICAL DEPTH.
11. WEEP HOLES AS REQUIRED.
12. INVERT SHAPING TO BE CONSTRUCTED IN THE FIELD BY CONTRACTOR, CHANNEL SLOPES AT 2 IN/FT, HALF DEPTH OF PIPE.

WEST VIRGINIA D.O.T. REF DR6-F

"F" INLET

PAGE 2 OF 2

Dwg: F- INLET WVDOT	Review Stamp	Seal for Precast Only
Orig Date: 3/27/24		
Last Rev:		
UID: F- INLET		
 <p>Concrete Pipe & Precast, LLC 800.999.2278 10364 Design Road Ashland, VA 23005</p>		

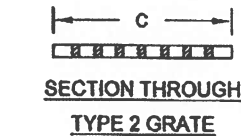
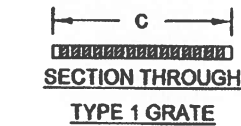
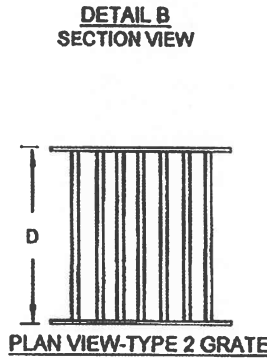
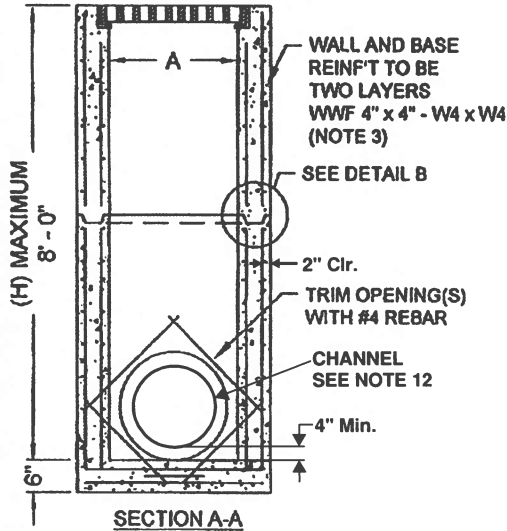
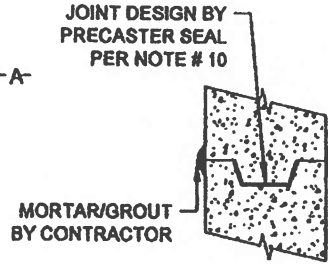
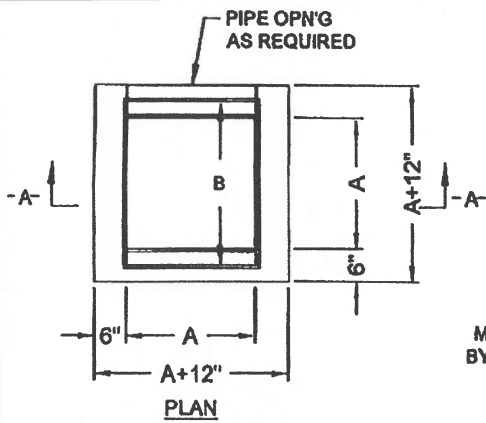

DIMENSIONS					
PIPE SIZE	A	B	C	D	H (MIN)
18"	2' - 8"	3' - 2"	2' - 7 3/4"	3' - 1 3/4"	2' - 0"
21"	2' - 8"	3' - 2"	2' - 7 3/4"	3' - 1 3/4"	2' - 3"
24"	2' - 8"	3' - 2"	2' - 7 3/4"	3' - 1 3/4"	2' - 6"
27"	3' - 0"	3' - 6"	2' - 11 3/4"	3' - 5 3/4"	2' - 9"
30"	3' - 8"	4' - 0"	3' - 5 3/4"	3' - 11 3/4"	3' - 0"
33"	3' - 9"	4' - 3"	3' - 8 3/4"	4' - 2 3/4"	3' - 3"
36"	4' - 0"	4' - 6"	3' - 11 3/4"	4' - 5 3/4"	3' - 6"
42"	4' - 6"	5' - 0"	4' - 6 3/4"	4' - 11 3/4"	4' - 0"
48"	5' - 0"	5' - 6"	4' - 11 3/4"	5' - 5 3/4"	4' - 6"

- NOTES:**
- INLET TO BE CONSTRUCTED IN ACCORDANCE WITH ASTM C 913.
 - CONCRETE MIX TO BE 5,000 PSI AT 28 DAYS MIN, TYPE II PORTLAND CEMENT.
 - REINFORCING DEFORMED BARS SHALL BE ASTM A-616, GR. 80, AND WELDED WIRE FABRIC REINFORCING IN ACCORDANCE WITH ASTM A185 & A82 GRADE 65. REINFORCING STEEL SHALL HAVE 1 1/2" CONCRETE COVER EACH FACE.
 - LADDER RUNGS INSTALLED IN VERTICAL ALIGNMENT DESIGNED TO PREVENT LATERAL SLIPPAGE, 1'-0" C/C MAX.
 - LIFT HOLES OR LIFT EYES PROVIDED IN EACH SECTION FOR HANDLING ARE TO BE FILLED WITH AN APPROVED NON-SHRINK GROUT OR CONCRETE BY CONTRACTOR AS SPECIFIED (IF APPLICABLE).
 - TRIM ALL OPNE'S IN BASE, WALLS, AND T/S WITH #4 DEFORMED BAR, UNLESS NOTED.
 - ANNULAR SPACE BETWEEN PIPE AND HOLE TO BE FILLED WITH AN APPROVED NON-SHRINK GROUT OR CONCRETE BY CONTRACTOR AS REQUIRED.
 - PROVIDE BENT CONTINUOUS WWF OR BAR AT WALL CORNERS TO PROVIDE CONTINUOUS HORIZONTAL REINFORCING. BAR LAPS 16 INCHES MINIMUM.
 - THE JOINTS ARE TO BE GROUTED WITH NON-SHRINK GROUT AND/OR MORTAR, INSIDE AND OUT, AND SEALED BY THE CONTRACTOR TO A WATERTIGHT SEAL. SEAL TO BE ACHIEVED USING NON-SHRINK GROUT, MORTAR, RUBBER GASKETS, AND/OR BITUMINOUS MASTIC AS REQUIRED BY CONTRACT DRAWINGS. RUBBER GASKET SEAL MEETS AASHTO M 188 TYPE B OR ASTM C 361 & ASTM C 443.
 - STANDARD PRECAST MANHOLE(S) ARE DESIGNED FOR LATERAL EARTH PRESSURES IN EXCESS OF 50 FEET OF VERTICAL DEPTH.
 - WEEP HOLES AS REQUIRED.
 - INVERT SHAPING TO BE CONSTRUCTED IN THE FIELD BY CONTRACTOR, CHANNEL SLOPES AT 2 IN/FT, HALF DEPTH OF PIPE.

"G" INLET

WEST VIRGINIA D.O.T. REF DR6-G

Dwg: "G" INLET - WVDOT	Review Stamp	Seal for Precast Only
Orig Date: 3/27/24		
Last Rev:		
UID:		
<p>Concrete Pipe & Precast, LLC 800.999.2278 10364 Design Road Ashland, VA 23005</p>		

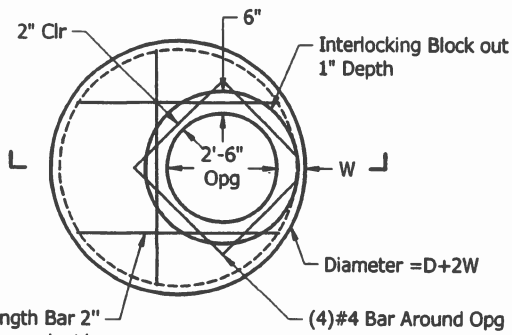

(1) Full Length Bar 2" from 30" Opg each side

**Plan View
Flattop Collar**

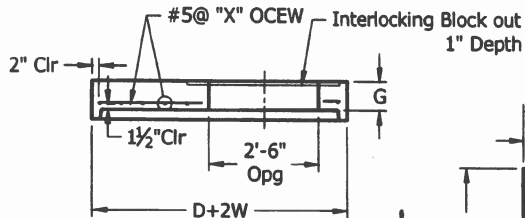

Section View

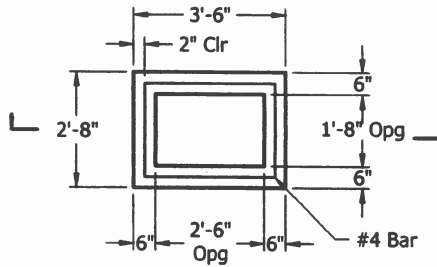

**Plan View
Adjustment Collar**

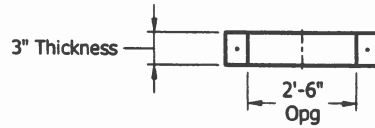

Section View

Circular Inlet Slab Dimensions			
D (in)	X (in)	G (in)	W
36"	N/A	N/A	4"
48"	5"	6"	5"
60"	8"	8"	6"
72"	8"	8"	7"
84"	6"	8"	8"
96"	6"	8"	9"
120"	5"	8"	10"

Notes:

- 1) This design is intended for precast structures produced by CP&P only.
- 2) Concrete to be 5000 PSI
- 3) Bar reinforcement conforms to ASTM A615 or A706, Grade 60 min.

**WVDOT Type E Inlet
Precast Flattop Collar and Adjustment Collar**

Dwg: WV-FTC-AC	Review Stamp	Seal for Precast Only
Orig Date: 2023-01-06		
Last Rev: ---		