

COLORS

LEGEND - BLUE (REF)
 BACKGROUND - WHITE (REF)

DIMENSIONS (INCHES)

A	B	C	D	E	F	G	H	J	K	L	M	N	P	Q	R
36	18	3/8	5/8	2 3/4	2D	1 3/4	2EM	1 1/2	3EM	2 1/4	4 3/4	8 3/8	15 1/4	15 7/8	1 1/8
66	30	1/2	3/4	4 1/2	4D	3	4EM	3	5EM	3 3/4	6 1/2	17 1/8	29 5/8	26 7/16	1 3/8

FOR USE IN GROUND MOUNTED INSTALLATIONS ONLY

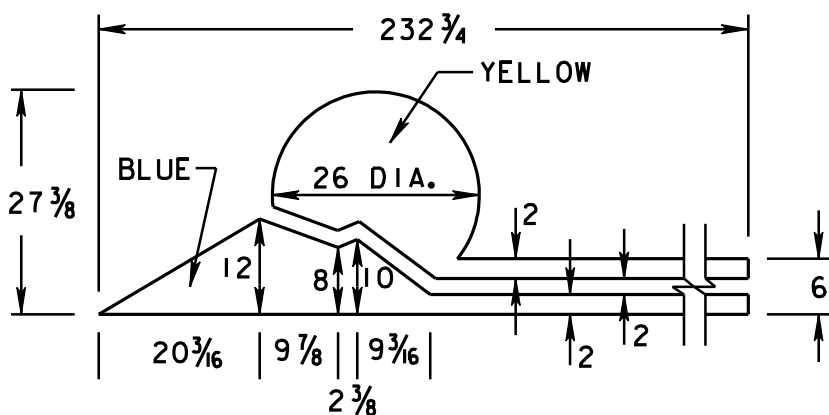
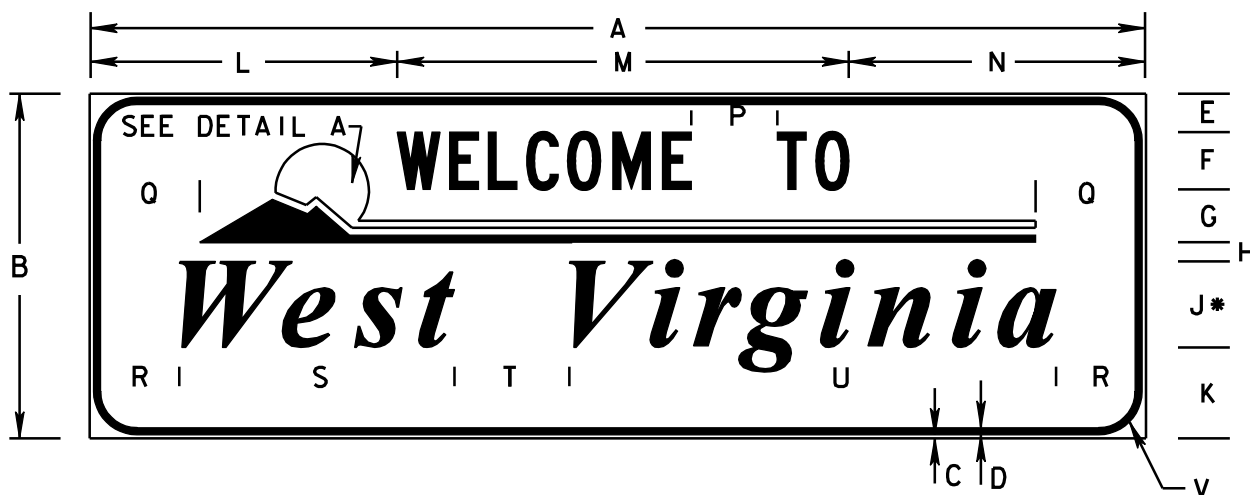

DETAIL A

COLORS

LEGEND - BLUE & YELLOW (REF)
 BACKGROUND - WHITE (REF)

DIMENSIONS (INCHES)

A	B	C	D	E	F	G	H	J	K	L	M	N	P
294	96	1	2	10 11/16	16	14 11/16	5 3/16	24	25 7/16	85 9/16	25 3/4	82 11/16	24

Q	R	S	T	U	V
30 5/8	24 15/16	76 5/8	32	135 1/2	12

FOR OVERHEAD USE ONLY

LEGEND & SYMBOL SHALL BE DEMOUNTABLE

BACKGROUND MATERIAL SHALL BE TYPE II REFLECTIVE SHEETING (HI-INT)

* - PRODUCED BY GERBER SIGNMAKER USING TIMES BOLD ITALICS

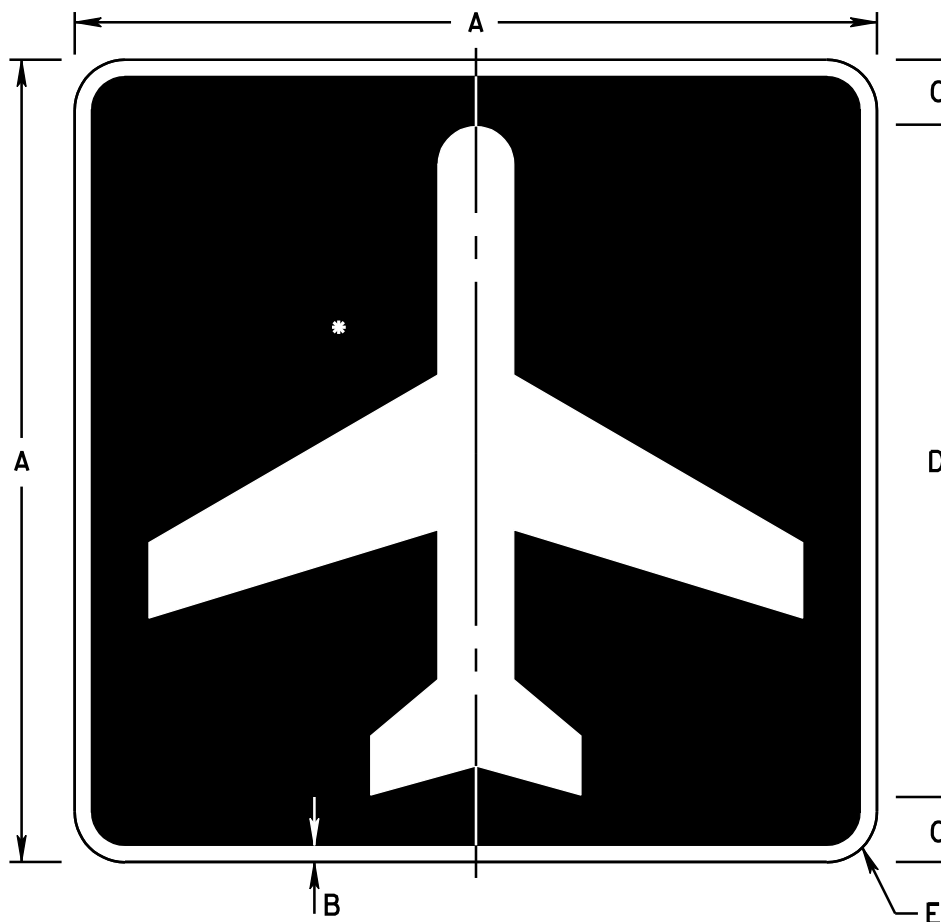

COLORS

SYMBOL - WHITE (REF)
 BACKGROUND - GREEN (REF)

DIMENSIONS (INCHES)

A	B	C	D	E
24	1/2	2	20	1 1/2
30	5/8	2 1/2	25	1 7/8

* - SEE APPENDIX FOR SYMBOL DESIGN
 SCHEDULED COMMERCIAL AIRPORT USE ONLY
 USE ARROWS 1-32, 1-33, AND 1-34

1-5 CODE	
24"	
30"	

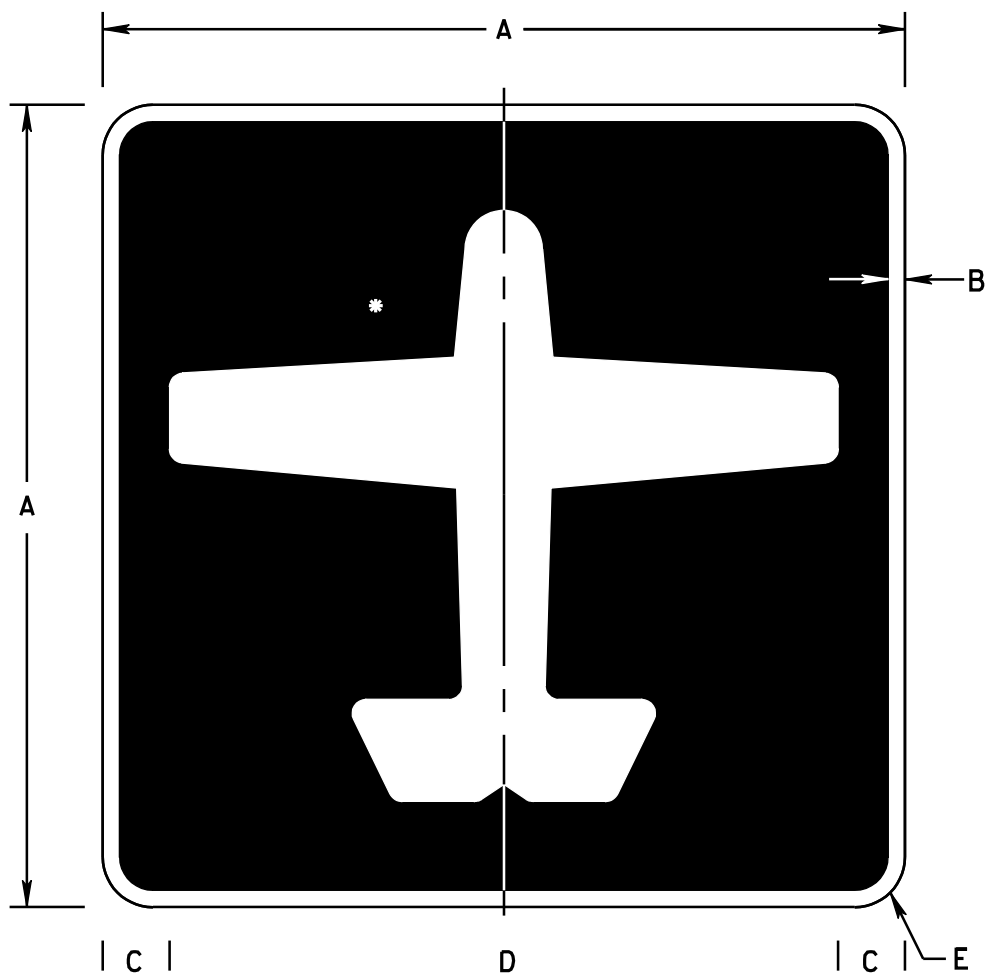

COLORS

SYMBOL - WHITE (REF)
 BACKGROUND - GREEN (REF)

DIMENSIONS (INCHES)

A	B	C	D	E
24	1/2	2	20	1 1/2
30	5/8	2 1/2	25	1 7/8

* - SEE APPENDIX FOR SYMBOL DESIGN
 NON-SCHEDULED GENERAL AVIATION AIRPORT USE ONLY
 USE ARROWS I-32, I-33, AND I-34

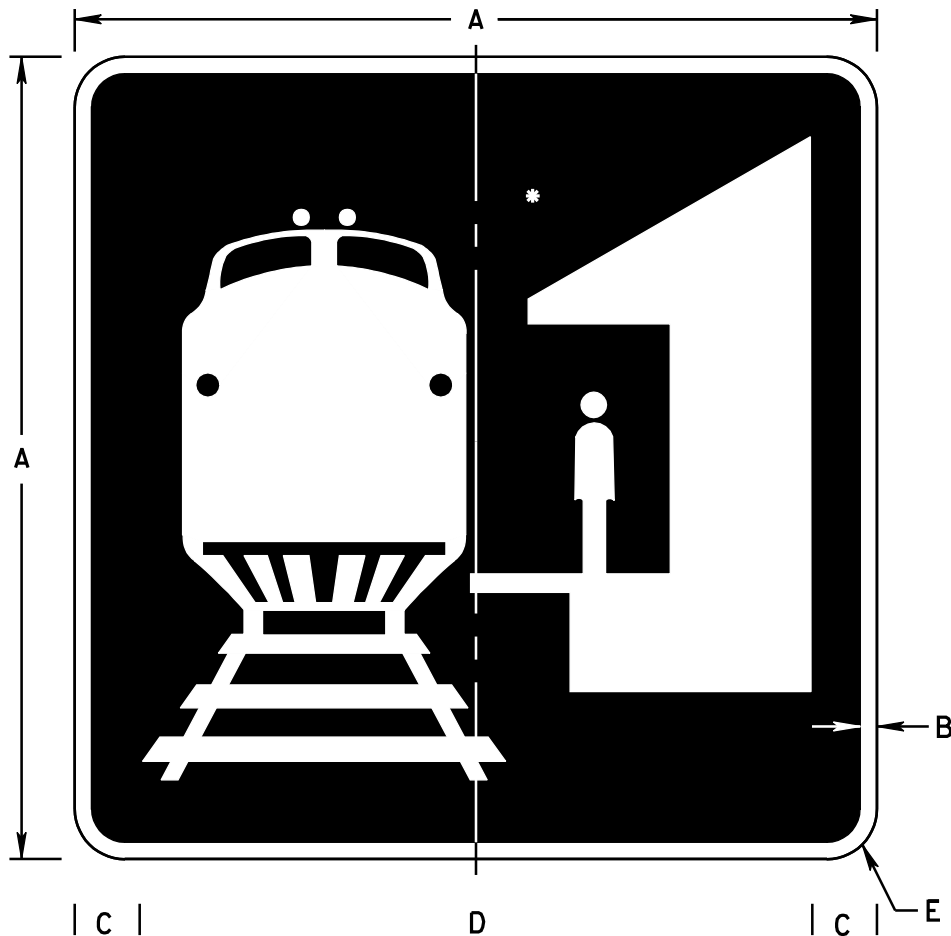

COLORS

SYMBOL - WHITE (REF)
 BACKGROUND - GREEN (REF)

DIMENSIONS (INCHES)

A	B	C	D	E
24	1/2	2	20	1 1/2
30	5/8	2 1/2	25	1 7/8

* - SEE APPENDIX FOR SYMBOL DESIGN
 USE ARROWS I-32, I-33, AND I-34

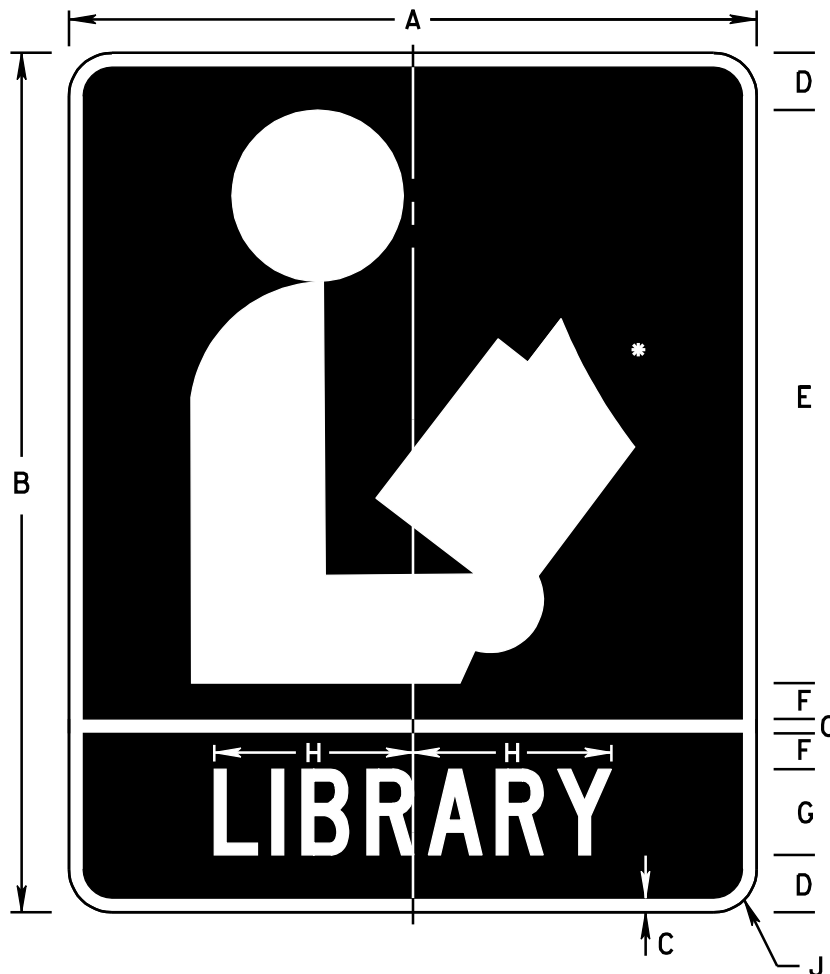

COLORS

SYMBOL & LEGEND - WHITE (REF)
 BACKGROUND - GREEN (REF)

DIMENSIONS (INCHES)

A	B	C	D	E	F	G	H	J
24	30	1/2	2	20	1 1/4	3C	6 15/16	1 1/2

* - SEE APPENDIX FOR SYMBOL DESIGN
 USE ARROWS I-32, I-33, AND I-34

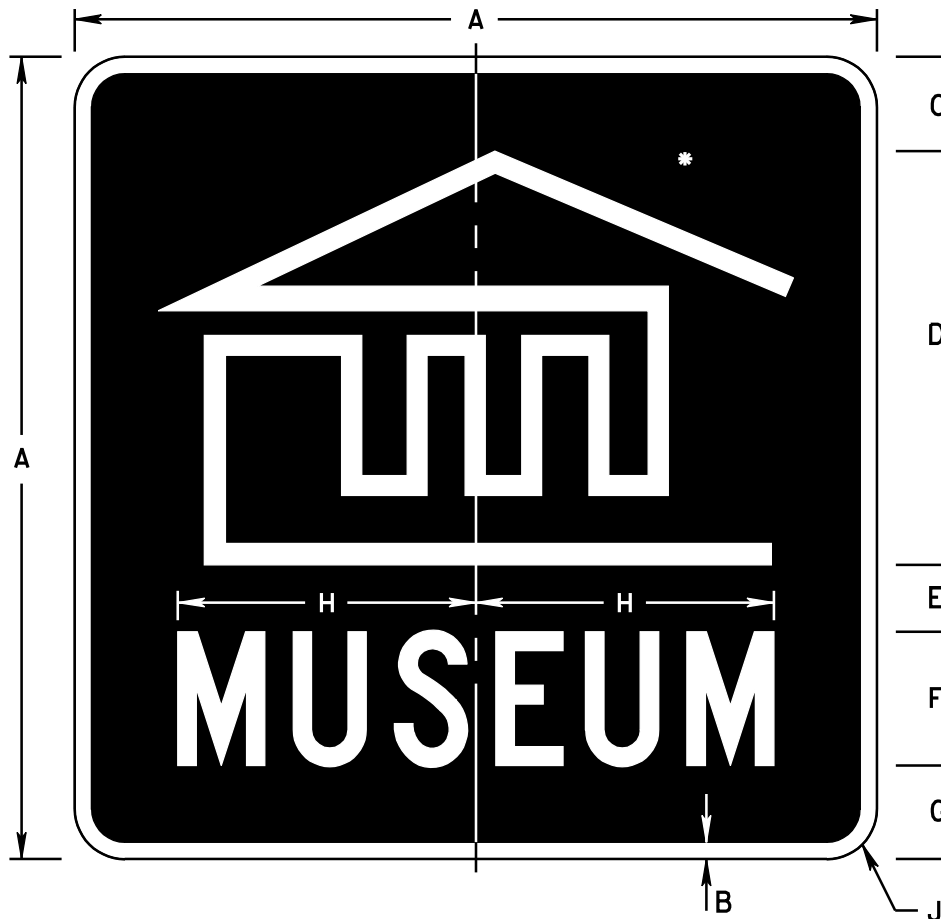

COLORS

SYMBOL - WHITE (REF)
 BACKGROUND - GREEN (REF)

DIMENSIONS (INCHES)

A	B	C	D	E	F	G	H	J
24	1/2	2 7/8	12 3/8	2	4C	2 3/4	8 15/16	1 1/2

* - SEE APPENDIX FOR SYMBOL DESIGN
 USE ARROWS I-32, I-33, AND I-34

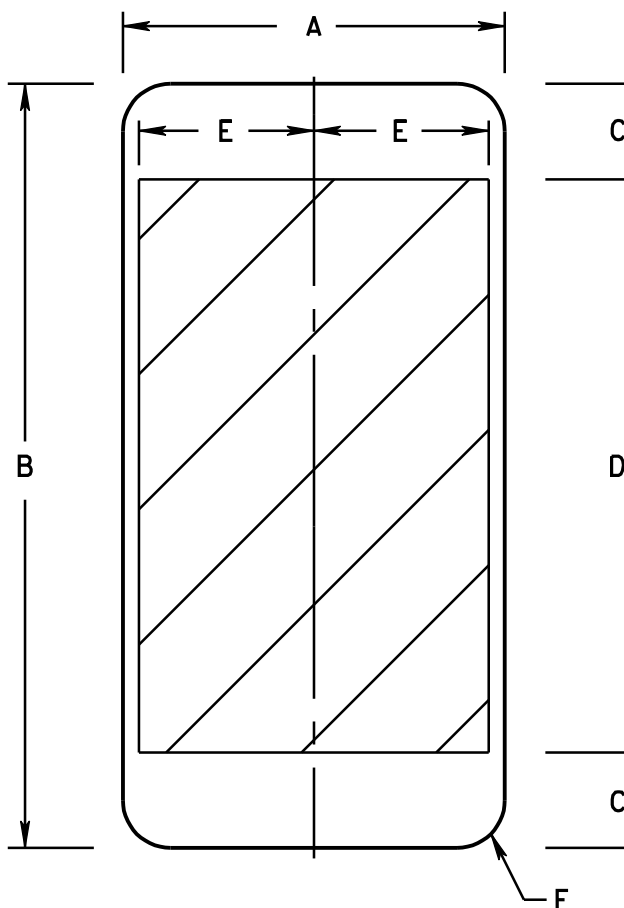

COLORS

LEGEND - BLACK (NON-REF)

BACKGROUND - WHITE (REF)

DIMENSIONS (INCHES)

A	B	C	D	E	F
4	8	1	6C	1 13/16	1/2

VISUALLY CENTER SINGLE NUMERAL (0-9) IN BOX

REFERENCE MILE MARKER

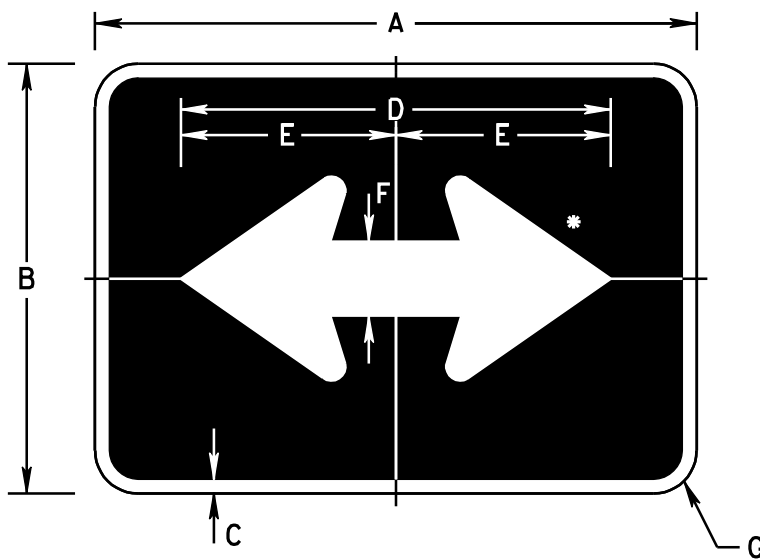

COLORS

LEGEND - WHITE (REF)
 BACKGROUND - GREEN (REF)

DIMENSIONS (INCHES)

A	B	C	D	E	F	G
12	9	1/2	8 3/4	4 3/8	1 5/8	1 1/2
21	15	1/2	15	7 1/2	2 5/8	1 1/2

* - SEE APPENDIX FOR ARROW DESIGN



I-32L

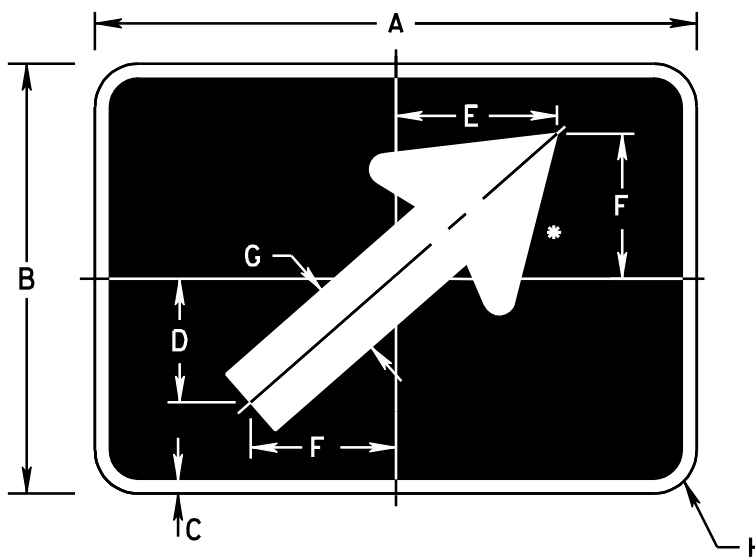

I-32R

COLORS

LEGEND - WHITE (REF)
 BACKGROUND - GREEN (REF)

DIMENSIONS (INCHES)

A	B	C	D	E	F	G	H
12	9	1/2	2 5/8	3 3/8	3	1 5/8	1 1/2
21	15	1/2	4 5/16	5 5/8	5 1/16	2 5/8	1 1/2

* - SEE APPENDIX FOR ARROW DESIGN

I-32R CODE	
12"x9"	
21"x15"	
I-32L CODE	
12"x9"	
21"x15"	

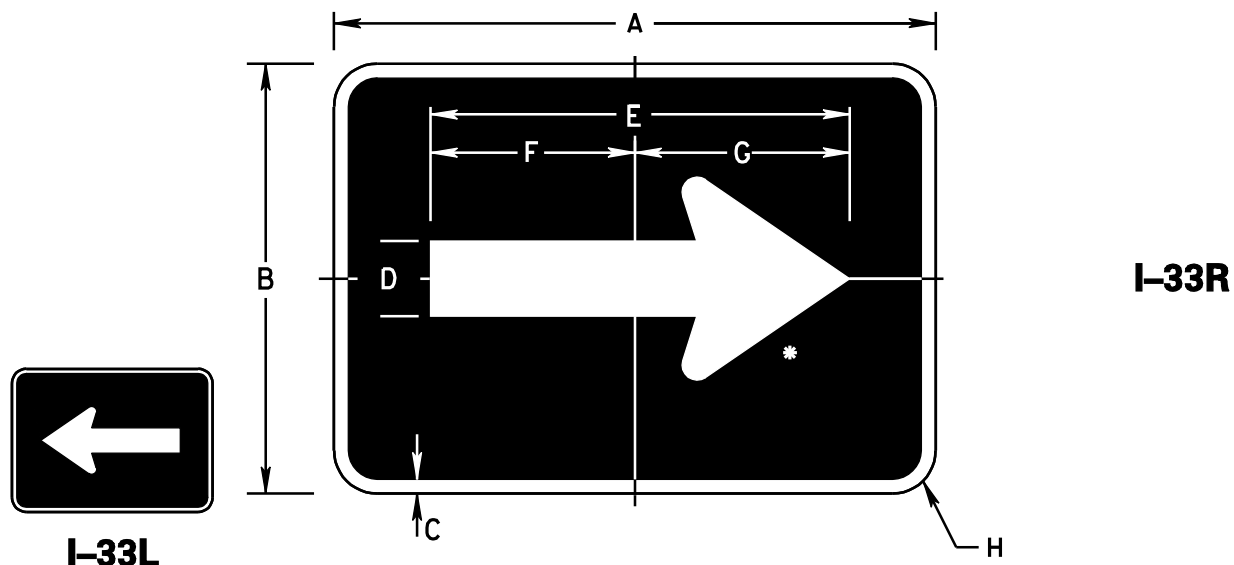

COLORS
 LEGEND - WHITE (REF)
 BACKGROUND - GREEN (REF)

DIMENSIONS (INCHES)

A	B	C	D	E	F	G	H
12	9	1/2	1 5/8	8 3/4	4 1/4	4 1/2	1 1/2
21	15	1/2	2 5/8	14 5/8	7 1/8	7 1/2	1 1/2

* - SEE APPENDIX FOR ARROW DESIGN

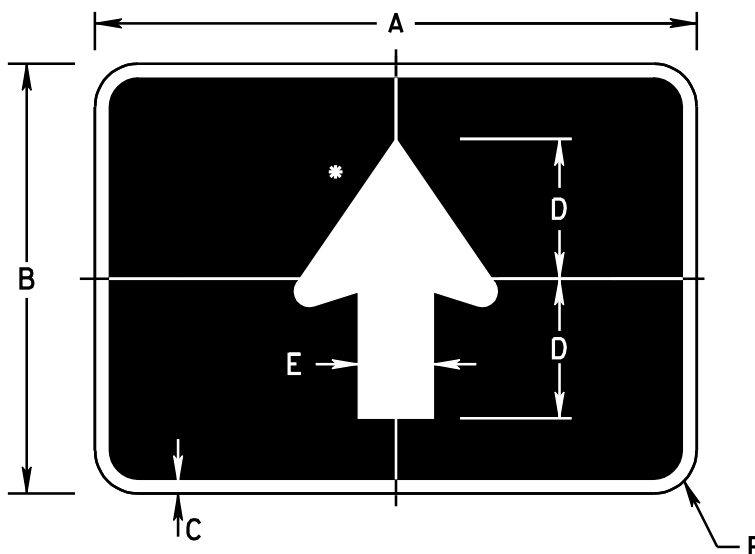

COLORS

LEGEND - WHITE (REF)
 BACKGROUND - GREEN (REF)

DIMENSIONS (INCHES)

A	B	C	D	E	F
12	9	1/2	3	1 5/8	1 1/2
21	15	1/2	4 3/4	2 5/8	1 1/2

* - SEE APPENDIX FOR ARROW DESIGN

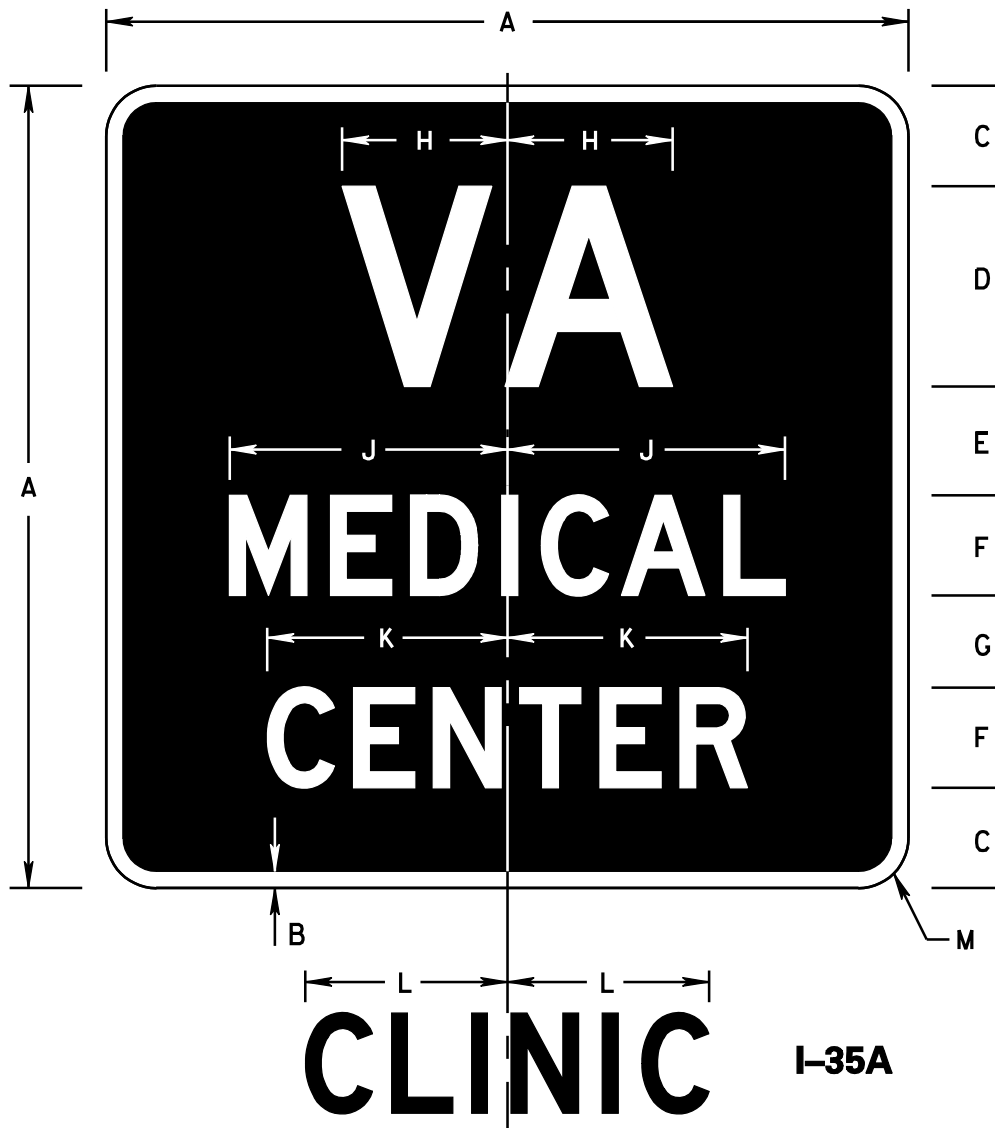

COLORS
 LEGEND - WHITE (REF)
 BACKGROUND - GREEN (REF)

DIMENSIONS (INCHES)

A	B	C	D	E	F	G	H	J	K	L	M
24	1/2	3	6D	3 1/4	3D	2 3/4	4 15/16	8 5/16	4 3/4	6 1/16	1 1/2
30	5/8	3 1/4	8D	4	4D	3 1/2	6 9/16	11 1/16	9 9/16	8 1/16	1 7/8

24" - RAMPS AND TRAILBLAZER USE ONLY
 30" - MAINLINE AND EXPRESSWAY USE ONLY
 USE ARROWS I-32, I-33, AND I-34

WV DEPARTMENT OF TRANSPORTATION
 DIVISION OF HIGHWAYS
 TRAFFIC ENGINEERING DIVISION

I-35 CODE		I-35A CODE	
24"	073535	24"	
30"		30"	

I-35

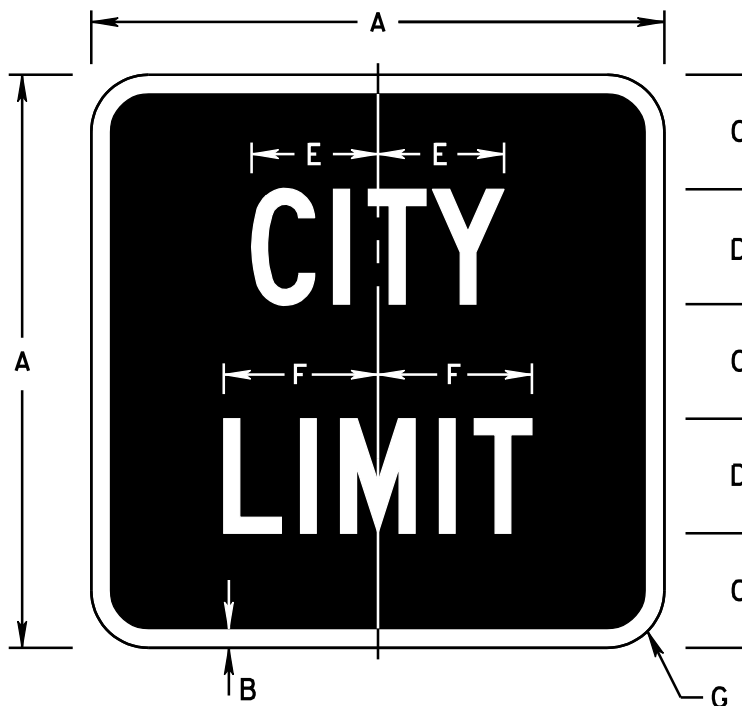

COLORS

LEGEND - WHITE (REF)
 BACKGROUND - GREEN (REF)

DIMENSIONS (INCHES)

A	B	C	D	E	F	G
15	1/2	3	3C	3 5/16	4	1 1/2