

**W1-1R**

**W1-1L**

**COLORS**  
 LEGEND - BLACK (NON-REF)  
 BACKGROUND - YELLOW (REF)

**DIMENSIONS (INCHES)**

A	B	C	D	E	F	G	H	J	K	L	M	N
18	3/8	5/8	7 1/4	2 1/4	2 5/8	5 7/8	3 3/4	1 7/8	1	5/8	2 1/2	1 1/8
24	3/8	5/8	9 5/8	3	3 1/2	7 3/4	5	2 1/2	1 1/2	13/16	3 1/4	1 1/8
30	1/2	3/4	12	3 3/4	4 3/8	9 11/16	6 1/4	3	1 7/8	1	4 1/16	1 3/8
36	5/8	7/8	14 3/8	4 1/2	5 1/4	11 5/8	7 1/2	3 5/8	2 1/4	1 1/4	4 7/8	1 5/8
48	3/4	1 1/4	19 3/16	6	7	15 1/2	10	4 7/8	3	1 5/8	6 1/2	2 1/4

\* - SEE APPENDIX FOR ARROW DESIGN

48" - WHEN USED IN CONSTRUCTION OR MAINTENANCE OPERATIONS  
 THE SIGN SHALL HAVE AN ORANGE REFLECTIVE BACKGROUND,  
 AND SHALL HAVE THE SUFFIX "M" ADDED TO THE FABRICATION NUMBER.

WV DEPARTMENT OF TRANSPORTATION  
 DIVISION OF HIGHWAYS  
 TRAFFIC ENGINEERING DIVISION

W1-1R CODE		W1-1L CODE	
18"		18"	
24"		24"	
30"		30"	
36"	020101	36"	020107
48"	020102	48"	020108
48" M	020103	48" M	020109

**W1-1**

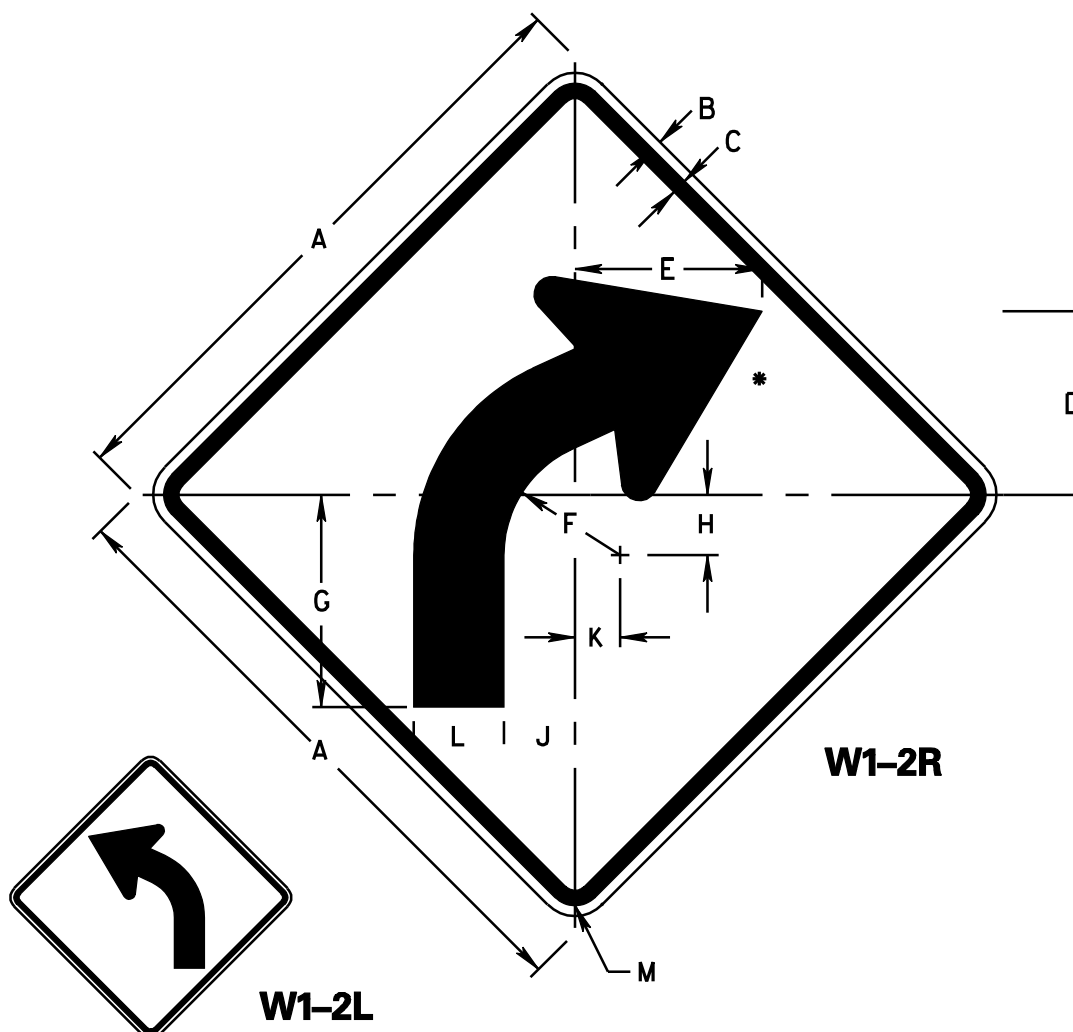

**W1-2R**

**W1-2L**

**COLORS**  
 LEGEND - BLACK (NON-REF)  
 BACKGROUND - YELLOW (REF)

**DIMENSIONS (INCHES)**

A	B	C	D	E	F	G	H	J	K	L	M
18	3/8	5/8	5 3/8	5 1/2	3 3/8	6 1/4	1 3/4	2	1 1/4	2 5/8	1 1/8
24	3/8	5/8	7 1/8	7 1/4	4 1/2	8 1/4	2 11/32	2 3/4	1 3/4	3 1/2	1 1/8
30	1/2	3/4	8 7/8	9 1/16	5 5/8	10 5/16	2 5/16	3 7/16	2 3/16	4 3/8	1 3/8
36	5/8	7/8	10 5/8	10 7/8	6 3/4	12 3/8	3 1/2	4 1/8	2 5/8	5 1/4	1 5/8
48	3/4	1 1/4	14 3/16	14 1/2	9	16 1/2	4 11/16	5 1/2	3 1/2	7	2 1/4

\* - SEE APPENDIX FOR ARROW DESIGN

48" - WHEN USED IN CONSTRUCTION OR MAINTENANCE OPERATIONS  
 THE SIGN SHALL HAVE AN ORANGE REFLECTIVE BACKGROUND,  
 AND SHALL HAVE THE SUFFIX "M" ADDED TO THE FABRICATION NUMBER.

WV DEPARTMENT OF TRANSPORTATION  
 DIVISION OF HIGHWAYS  
 TRAFFIC ENGINEERING DIVISION

W1-2R CODE	W1-2L CODE
18"	18"
24"	24"
30"	020113
36"	020114
48"	020115
48"M	48"M

**W1-2**

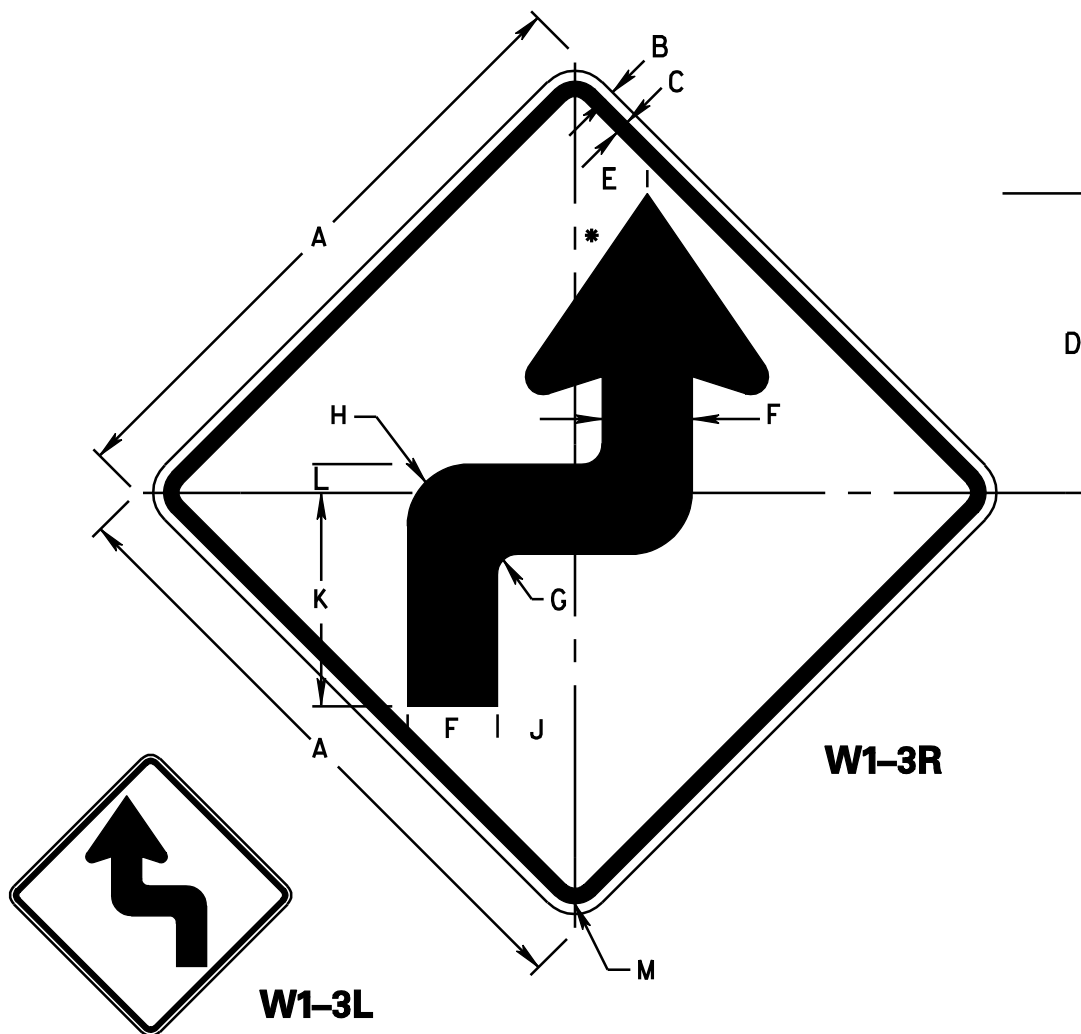

**W1-3R**

**W1-3L**

**COLORS**  
 LEGEND - BLACK (NON-REF)  
 BACKGROUND - YELLOW (REF)

**DIMENSIONS (INCHES)**

A	B	C	D	E	F	G	H	J	K	L	M
18	3/8	5/8	8 27/32	2 7/64	2 5/8	5/8	1 13/16	2 1/4	6 15/64	5 3/64	1 1/8
24	3/8	5/8	11 19/32	2 13/16	3 1/2	13/16	2 1/2	3	8 5/16	1 3/32	1 1/8
30	1/2	3/4	14 1/2	3 1/2	4 3/8	1	3	3 3/4	10 3/8	1 3/8	1 3/8
36	5/8	7/8	17 7/16	4 7/32	5 1/4	1 1/4	3 5/8	4 1/2	12 15/32	1 2/32	1 5/8
48	3/4	1 1/4	23 3/16	5 5/8	7	1 5/8	4 7/8	6	16 5/8	2 3/16	2 1/4

\* - SEE APPENDIX FOR ARROW DESIGN

48" - WHEN USED IN CONSTRUCTION OR MAINTENANCE OPERATIONS  
 THE SIGN SHALL HAVE AN ORANGE REFLECTIVE BACKGROUND,  
 AND SHALL HAVE THE SUFFIX "M" ADDED TO THE FABRICATION NUMBER.

WV DEPARTMENT OF TRANSPORTATION  
 DIVISION OF HIGHWAYS  
 TRAFFIC ENGINEERING DIVISION

W1-3R CODE		W1-3L CODE	
18"		18"	
24"		24"	
30"	020125	30"	020132
36"	020126	36"	020133
48"	020127	48"	020134
48"M	020128	48"M	020135

**W1-3**

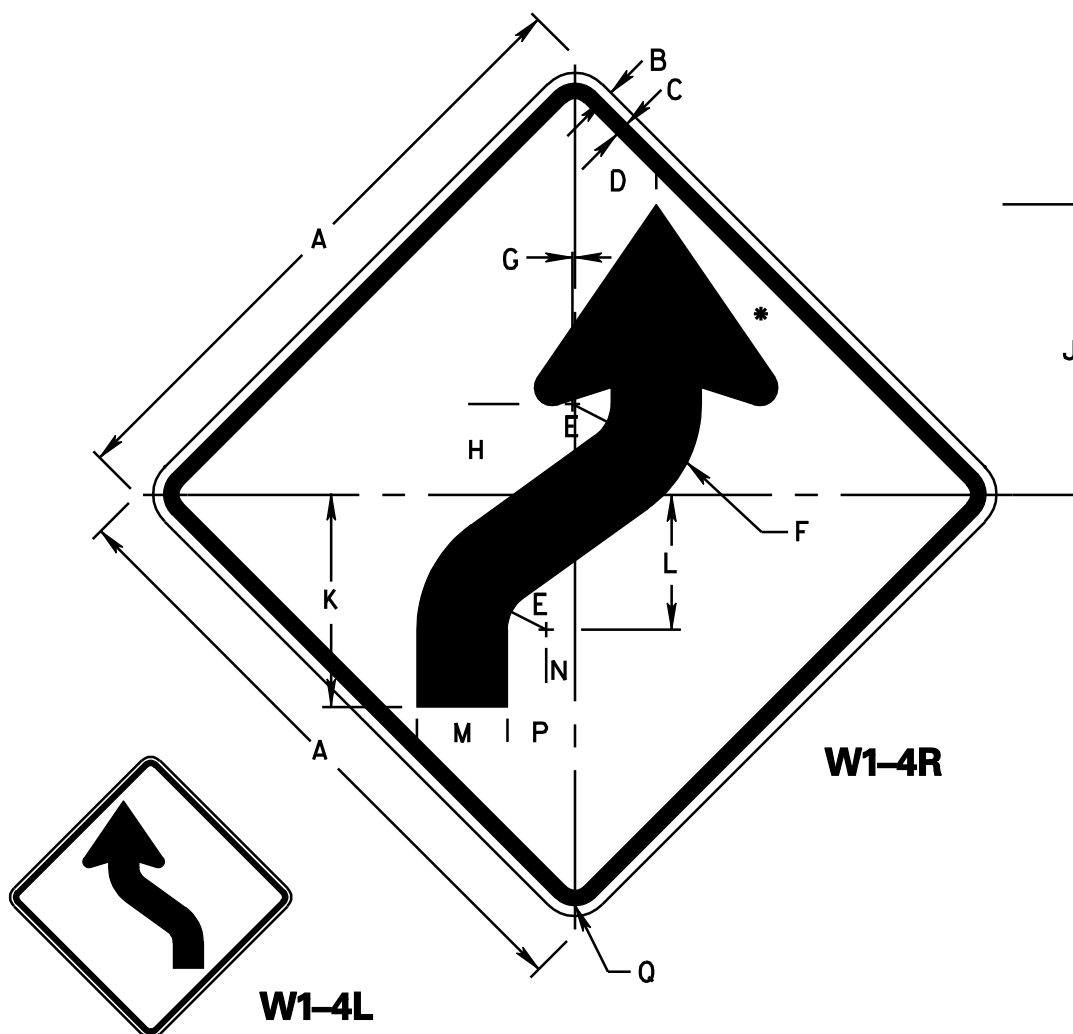

COLORS  
 LEGEND - BLACK (NON-REF)  
 BACKGROUND - YELLOW (REF)

DIMENSIONS (INCHES)

A	B	C	D	E	F	G	H	J	K	L	M	N	P	Q
18	3/8	5/8	2 3/8	1 1/8	3 3/4	1/16	2 5/8	8 5/8	6 1/4	4	2 5/8	7/8	2	1 1/8
24	3/8	5/8	3 3/2	1 1/2	5	3/32	3 1/2	11 1/4	8 1/4	5 1/4	3 1/2	1 1/8	2 5/8	1 1/8
30	1/2	3/4	3 5/16	1 7/8	6 1/4	1/8	4 3/8	14 1/16	10 5/16	6 9/16	4 3/8	1 13/32	3 9/32	1 3/8
36	5/8	7/8	4 21/32	2 1/4	7 1/2	5/32	5 1/4	16 7/8	12 3/8	7 7/8	5 1/4	1 11/16	3 15/16	1 5/8
48	3/4	1 1/4	6 5/16	3	10	3/16	7	22 1/2	16 1/2	10 1/2	7	2 1/4	5 1/4	2 1/4

\* - SEE APPENDIX FOR ARROW DESIGN  
 48" - WHEN USED IN CONSTRUCTION OR MAINTENANCE OPERATIONS  
 THE SIGN SHALL HAVE AN ORANGE REFLECTIVE BACKGROUND,  
 AND SHALL HAVE THE SUFFIX "M" ADDED TO THE FABRICATION NUMBER.

WV DEPARTMENT OF TRANSPORTATION  
 DIVISION OF HIGHWAYS  
 TRAFFIC ENGINEERING DIVISION

W1-4R CODE		W1-4L CODE	
18"		18"	
24"		24"	
30"	020139	30"	020146
36"	020140	36"	020147
48"	020141	48"	020148
48" M	020143	48" M	020150

**W1-4**

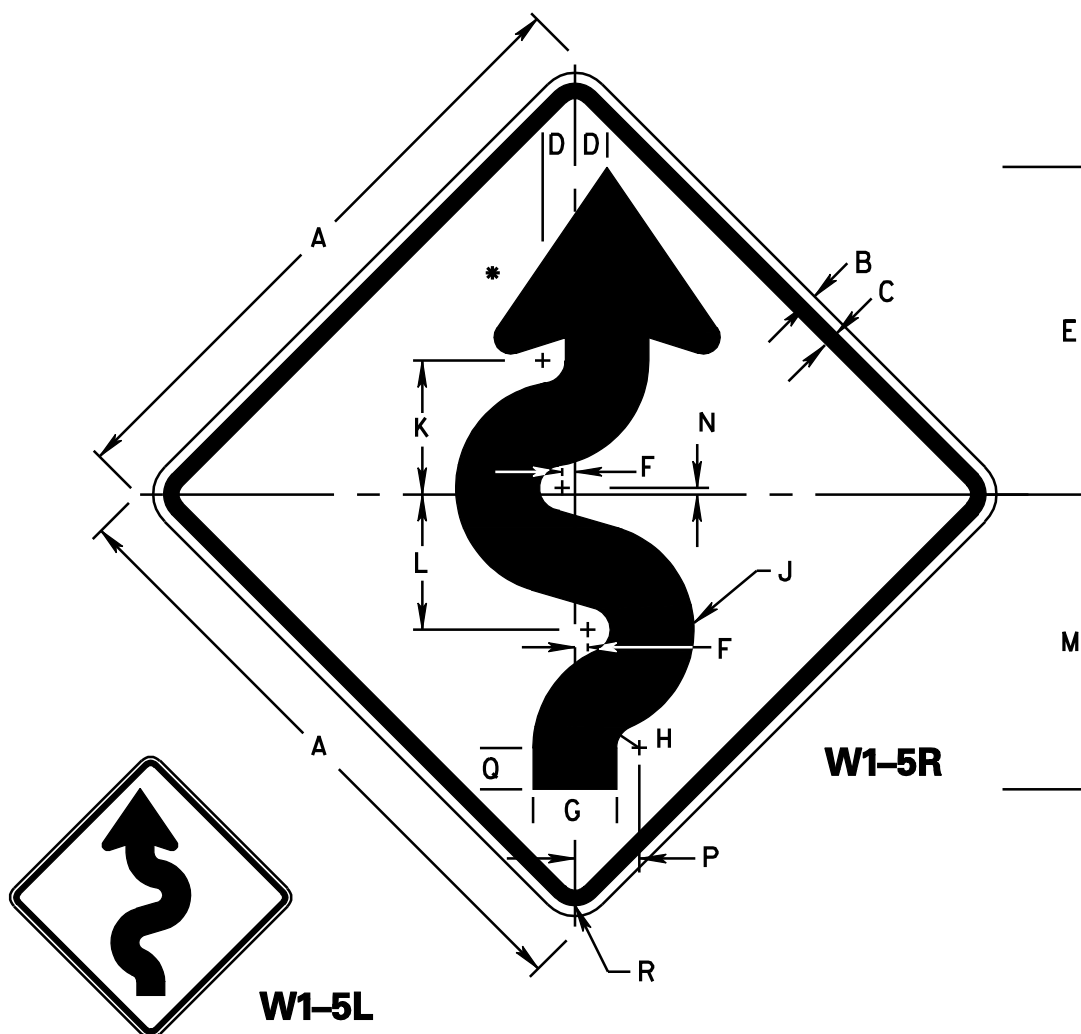

W1-5R

W1-5L

COLORS  
 LEGEND - BLACK (NON-REF)  
 BACKGROUND - YELLOW (REF)

DIMENSIONS (INCHES)

A	B	C	D	E	F	G	H	J	K	L	M	N	P	Q	R
18	3/8	5/8	1	9 5/8	3/8	2 1/2	5/8	3	4	4	8 5/8	1/4	2	1 1/4	1 1/8
24	3/8	5/8	1 1/4	12 3/4	1/2	3 1/4	7/8	4 1/8	5 3/16	5 1/4	11 3/8	1/4	2 1/2	1 19/32	1 1/8
30	1/2	3/4	1 9/16	15 15/16	5/8	4 1/16	1 3/32	5 5/32	6 3/64	6 9/16	14 7/32	5/16	3 1/8	2	1 3/8
36	5/8	7/8	1 7/8	19 1/8	3/4	4 7/8	1 5/16	6 3/16	7 25/32	7 7/8	17 1/16	3/8	3 3/4	2 13/32	1 5/8
48	3/4	1 1/4	2 1/2	25 1/2	1	6 1/2	1 3/4	8 1/4	10 3/8	10 1/2	22 3/4	1/2	5	3 3/16	2 1/4

\* - SEE APPENDIX FOR ARROW DESIGN

WV DEPARTMENT OF TRANSPORTATION  
 DIVISION OF HIGHWAYS  
 TRAFFIC ENGINEERING DIVISION

W1-5R CODE	W1-5L CODE
18"	18"
24"	24"
30" 020153	30" 020159
36" 020154	36" 020160
48" 020155	48" 020161

W1-5

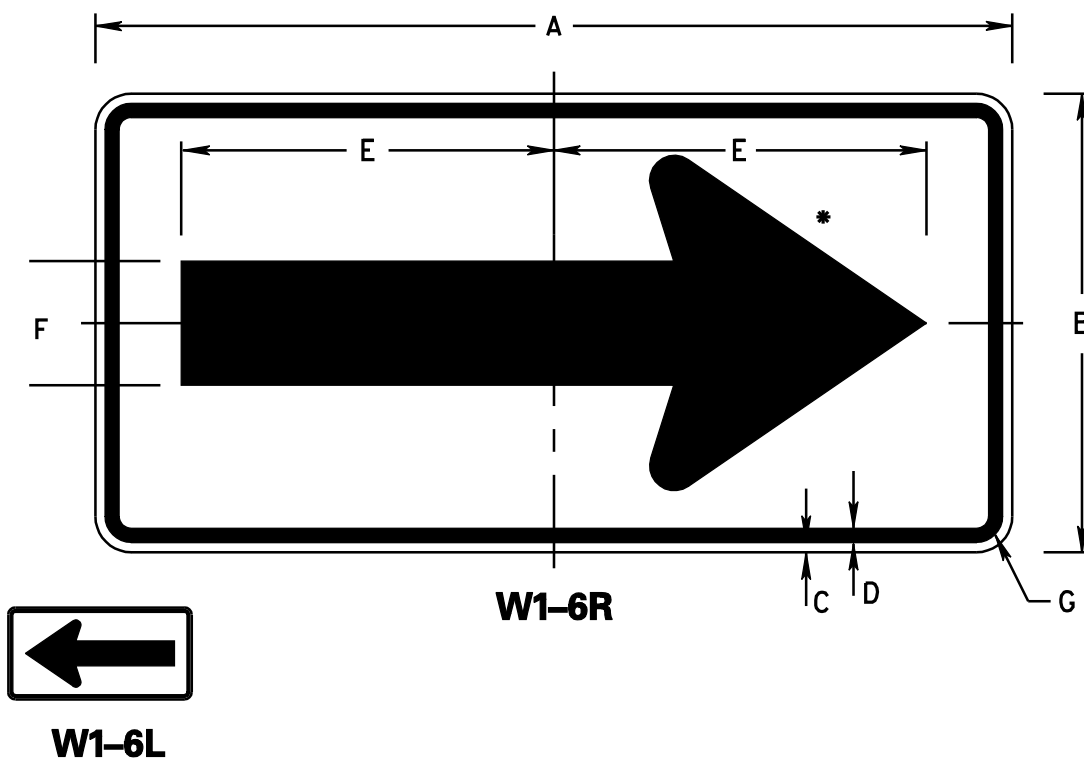

**W1-6R**

**W1-6L**

**COLORS**

LEGEND - BLACK (NON-REF)  
 BACKGROUND - YELLOW (REF)

**DIMENSIONS (INCHES)**

A	B	C	D	E	F	G
24	12	3/8	3/8	9 5/8	3 1/4	1 1/8
36	18	3/8	5/8	14 5/8	5	1 1/8
48	24	1/2	3/4	19 1/2	6 1/2	1 3/8
60	30	5/8	7/8	24 3/8	8	1 5/8
72	36	5/8	7/8	29 1/4	9 3/8	1 5/8

\* - SEE APPENDIX FOR ARROW DESIGN  
 WHEN USED IN CONSTRUCTION OR MAINTENANCE OPERATIONS  
 THE SIGN SHALL HAVE AN ORANGE REFLECTIVE BACKGROUND,  
 AND SHALL HAVE THE SUFFIX "M" ADDED TO THE FABRICATION NUMBER.  
 PAINTING OPERATIONS USE 72" X 36" SIGN.

WV DEPARTMENT OF TRANSPORTATION  
 DIVISION OF HIGHWAYS  
 TRAFFIC ENGINEERING DIVISION

W1-6 CODE		W1-6M CODE	
24"x12"		24"x12"	
36"x18"		36"x18"	
48"x24"	020165	48"x24"	020167
60"x30"	020166	60"x30"	020169
72"x36"		72"x36"	020168

**W1-6**

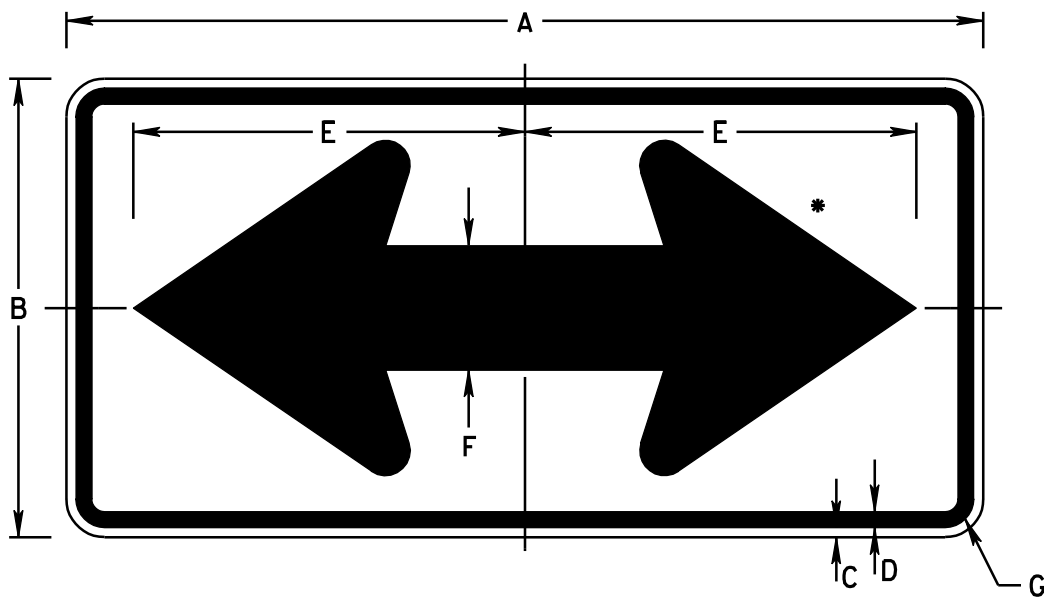

COLORS

LEGEND - BLACK (NON-REF)  
 BACKGROUND - YELLOW (REF)

DIMENSIONS (INCHES)

A	B	C	D	E	F	G
24	12	$\frac{3}{8}$	$\frac{3}{8}$	$10\frac{3}{8}$	$3\frac{1}{4}$	$1\frac{1}{8}$
36	18	$\frac{3}{8}$	$\frac{5}{8}$	$15\frac{5}{8}$	5	$1\frac{1}{8}$
48	24	$\frac{1}{2}$	$\frac{3}{4}$	$20\frac{1}{2}$	$6\frac{1}{2}$	$1\frac{3}{8}$
60	30	$\frac{5}{8}$	$\frac{7}{8}$	$25\frac{3}{8}$	8	$1\frac{5}{8}$

\* - SEE APPENDIX FOR ARROW DESIGN

W1-7 CODE	
24"x12"	
36"x18"	
48"x24"	
60"x30"	

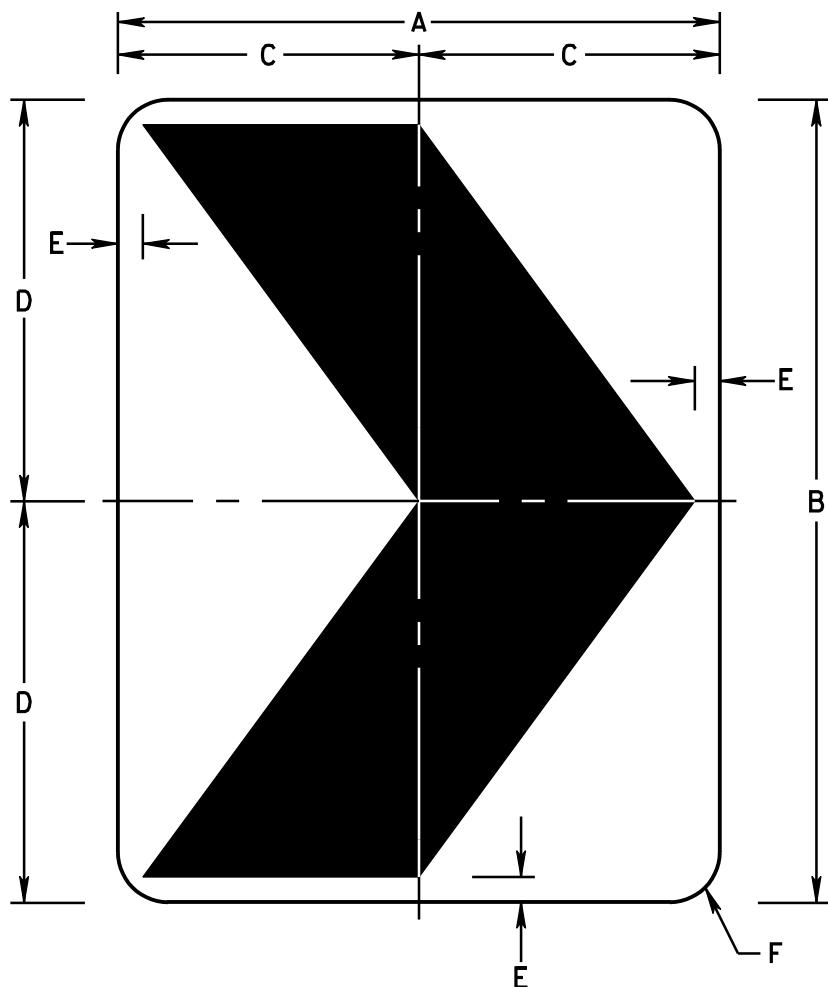

COLORS

CHEVRON - BLACK (NON-REF)

BACKGROUND - YELLOW (FLUORESCENT)

DIMENSIONS (INCHES)

A	B	C	D	E	F
18	24	9	12	3/4	1 1/2
30	36	15	18	1	1 1/2
36	48	18	24	1 1/8	1 1/2

18"x24" AND 30"x36" - WHEN USED IN CONSTRUCTION OR MAINTENANCE OPERATIONS THE SIGN SHALL HAVE AN ORANGE REFLECTIVE BACKGROUND, AND SHALL HAVE THE SUFFIX "M" ADDED TO THE FABRICATION NUMBER.

W1-8 CODE		W1-8M CODE	
18"x24"	020172	18"x24"	
30"x36"	020174	30"x36"	
36"x48"			



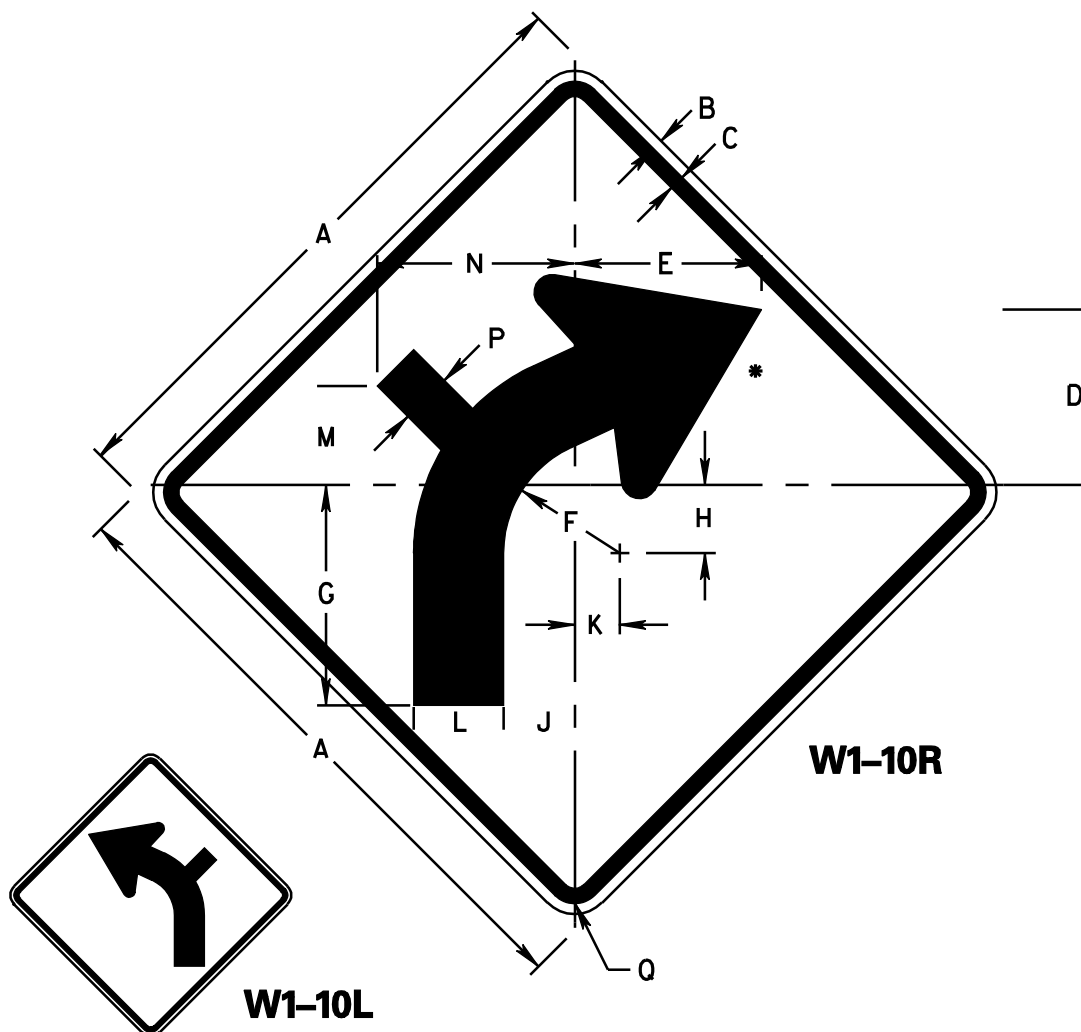

COLORS  
 LEGEND - BLACK (NON-REF)  
 BACKGROUND - YELLOW (REF)

DIMENSIONS (INCHES)

A	B	C	D	E	F	G	H	J	K	L	M	N	P	Q
18	$\frac{3}{8}$	$\frac{5}{8}$	$5\frac{3}{8}$	$5\frac{1}{2}$	$3\frac{1}{4}$	$6\frac{1}{4}$	$1\frac{3}{4}$	2	$1\frac{1}{4}$	$2\frac{5}{8}$	$3\frac{1}{8}$	$5\frac{3}{4}$	$1\frac{1}{2}$	$1\frac{1}{8}$
24	$\frac{3}{8}$	$\frac{5}{8}$	$7\frac{1}{8}$	$7\frac{1}{4}$	$4\frac{1}{2}$	$8\frac{1}{4}$	$2\frac{11}{32}$	$2\frac{3}{4}$	$1\frac{3}{4}$	$3\frac{1}{2}$	$4\frac{1}{8}$	$7\frac{11}{16}$	2	$1\frac{1}{8}$
30	$\frac{1}{2}$	$\frac{3}{4}$	$8\frac{7}{8}$	$9\frac{1}{16}$	$5\frac{5}{8}$	$10\frac{5}{16}$	$2\frac{5}{16}$	$3\frac{7}{16}$	$2\frac{3}{16}$	$4\frac{3}{8}$	$5\frac{3}{16}$	$9\frac{9}{16}$	$2\frac{1}{2}$	$1\frac{3}{8}$
36	$\frac{5}{8}$	$\frac{7}{8}$	$10\frac{5}{8}$	$10\frac{7}{8}$	$6\frac{3}{4}$	$12\frac{3}{8}$	$3\frac{1}{2}$	$4\frac{1}{8}$	$2\frac{5}{8}$	$5\frac{1}{4}$	$6\frac{3}{16}$	$11\frac{1}{2}$	3	$1\frac{5}{8}$
48	$\frac{3}{4}$	$1\frac{1}{4}$	$14\frac{3}{16}$	$14\frac{1}{2}$	9	$16\frac{1}{2}$	$4\frac{11}{16}$	$5\frac{1}{2}$	$3\frac{1}{2}$	7	$8\frac{1}{4}$	$15\frac{5}{16}$	4	$2\frac{1}{4}$

\* - SEE APPENDIX FOR ARROW DESIGN

WV DEPARTMENT OF TRANSPORTATION  
 DIVISION OF HIGHWAYS  
 TRAFFIC ENGINEERING DIVISION

W1-10R CODE	W1-10L CODE
18"	18"
24"	24"
30"	30"
36"	36"
48"	48"

**W1-10**

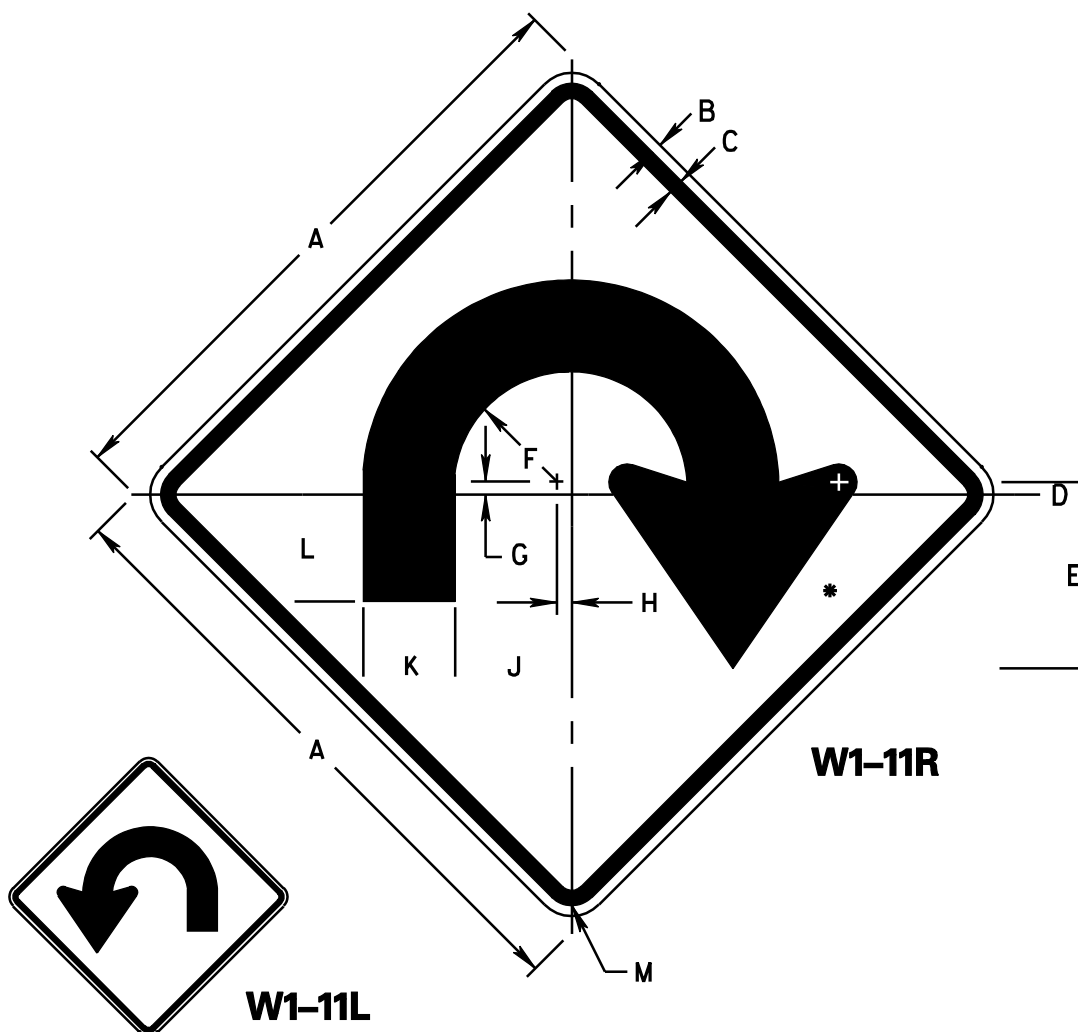

**COLORS**  
 LEGEND - BLACK (NON-REF)  
 BACKGROUND - YELLOW (REF)

**DIMENSIONS (INCHES)**

A	B	C	D	E	F	G	H	J	K	L	M
36	5/8	7/8	13/16	10 11/16	6 11/16	7/16	1/4	6 7/8	5 1/4	6	1 5/8
48	3/4	1 1/4	1	14 3/16	8 7/8	1 5/8	3/8	9 3/16	7	8	1 5/8
60	3/4	1 1/4	1 1/4	17 3/4	11 1/8	2	1/2	11 1/2	8 3/4	10	2 1/4

TO BE USED ON FREEWAY RAMPS ONLY  
 \* SEE APPENDIX FOR ARROW DESIGN

W1-11R CODE	W1-11L CODE
36" 020176	36"
48" 020177	48"
60" 020178	60"

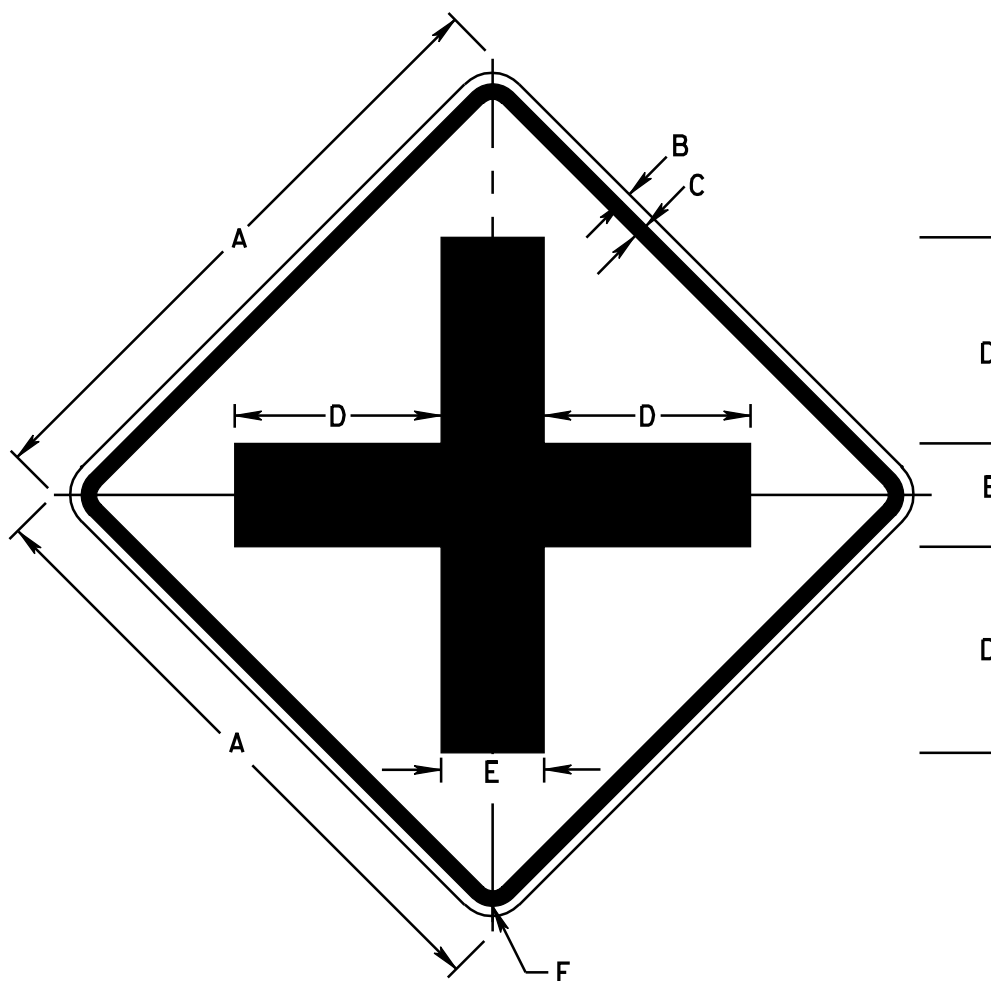

COLORS

LEGEND - BLACK (NON-REF)  
 BACKGROUND - YELLOW (REF)

DIMENSIONS (INCHES)

A	B	C	D	E	F
18	3/8	5/8	6	3	1 1/8
30	1/2	3/4	10	5	1 3/8
36	5/8	7/8	12	6	1 5/8
48	3/4	1 1/4	16	8	2 1/4

W2-1 CODE	
18"	
30"	020201
36"	020202
48"	020203

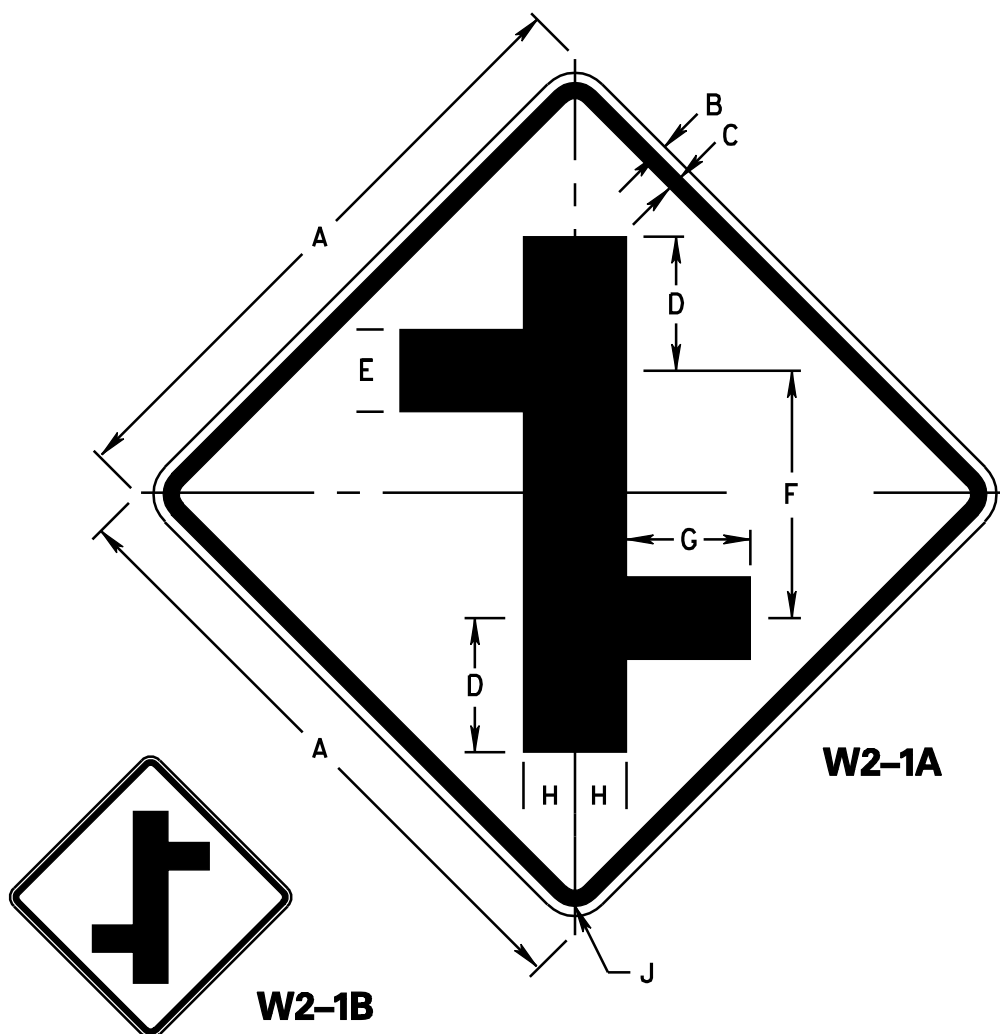

COLORS  
 LEGEND - BLACK (NON-REF)  
 BACKGROUND - YELLOW (REF)

DIMENSIONS (INCHES)

A	B	C	D	E	F	G	H	J
30	1/2	3/4	6 1/2	4	12	6	2 1/2	1 3/8
36	5/8	7/8	7 3/4	4 3/4	14 3/8	7 3/16	3	1 5/8
48	3/4	1 1/4	10 3/8	6 3/8	19 3/16	9 9/16	4	2 1/4

WV DEPARTMENT OF TRANSPORTATION  
 DIVISION OF HIGHWAYS  
 TRAFFIC ENGINEERING DIVISION

W2-1A CODE	W2-1B CODE
30" 020207	30" 020213
36" 020208	36" 020214
48" 020209	48" 020215

**W2-1A**

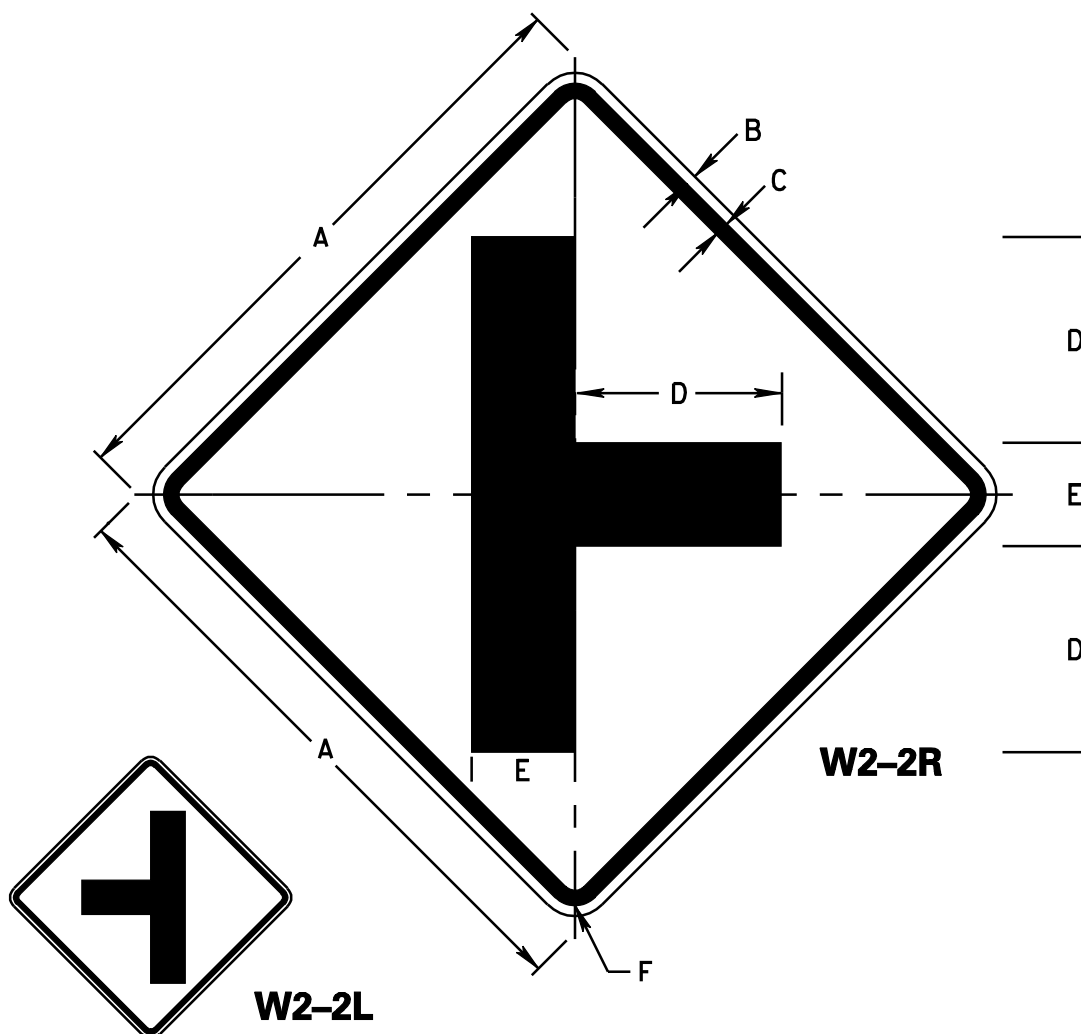

**COLORS**

LEGEND - BLACK (NON-RE)  
BACKGROUND - YELLOW (REF)

**DIMENSIONS (INCHES)**

A	B	C	D	E	F
18	3/8	5/8	6	3	1 1/8
30	1/2	3/4	10	5	1 3/8
36	5/8	7/8	12	6	1 5/8
48	3/4	1 1/4	16	8	2 1/4

W2-2R CODE	W2-2L CODE
18"	18"
30"	020225 30"
36"	020226 36"
48"	020227 48"

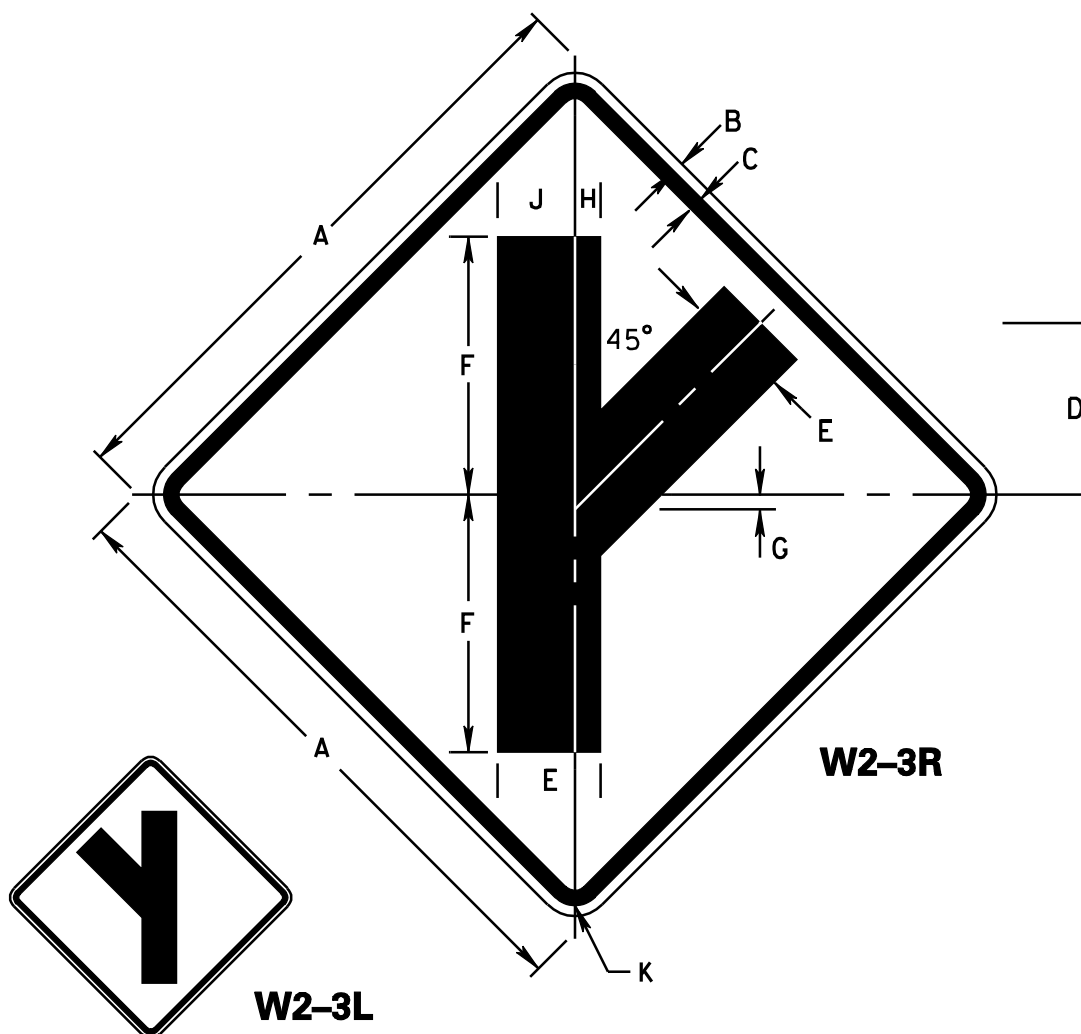

**COLORS**

LEGEND - BLACK (NON-REF)  
 BACKGROUND - YELLOW (REF)

**DIMENSIONS (INCHES)**

A	B	C	D	E	F	G	H	J	K
18	3/8	5/8	5	3	7 3/4	3/8	3/4	2 1/4	1 1/8
30	1/2	3/4	8 5/16	5	12 1/2	1/16	1 1/4	3 3/4	1 3/8
36	5/8	7/8	10	6	15	2 1/32	1 1/2	4 1/2	1 5/8
48	3/4	1 1/4	13 5/16	8	20	1 1/8	2	6	2 1/4

WV DEPARTMENT OF TRANSPORTATION  
 DIVISION OF HIGHWAYS  
 TRAFFIC ENGINEERING DIVISION

W2-3R CODE	W2-3L CODE
18"	18"
30"	020231 30"
36"	020232 36"
48"	020233 48"

**W2-3**

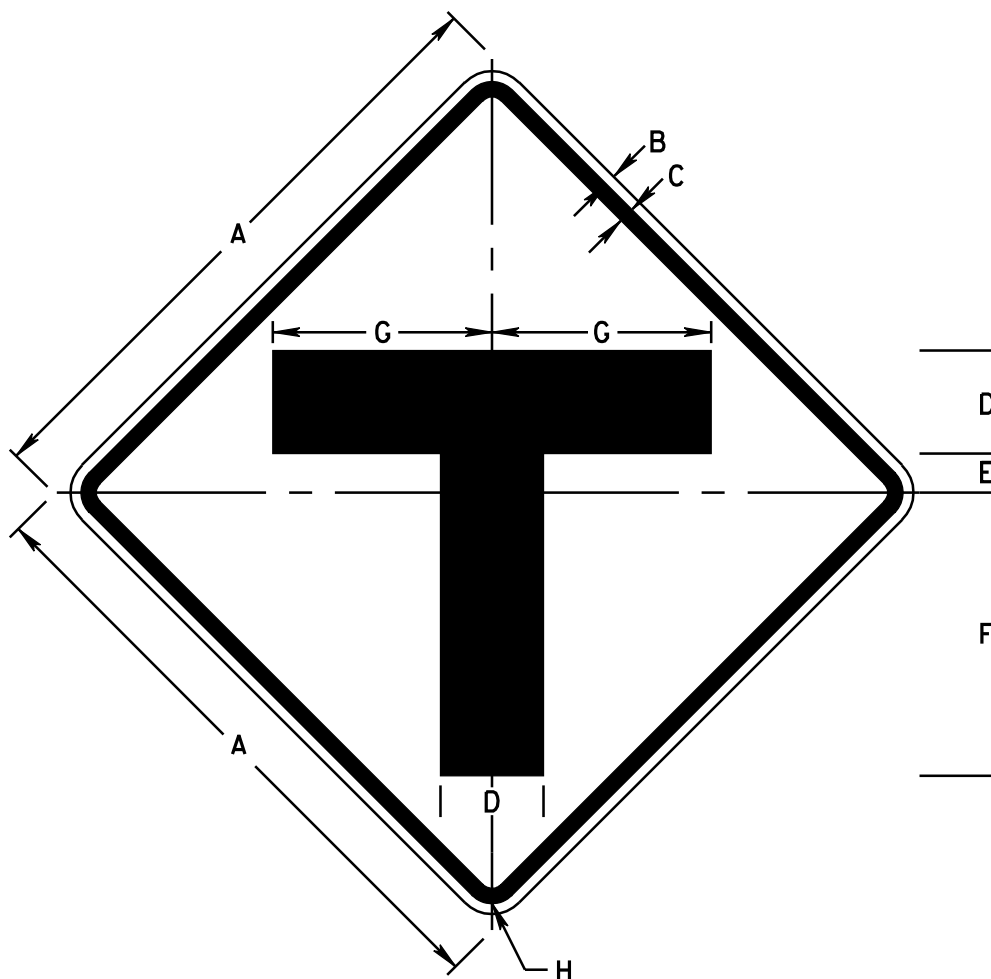

COLORS

LEGEND - BLACK (NON-REF)  
 BACKGROUND - YELLOW (REF)

DIMENSIONS (INCHES)

A	B	C	D	E	F	G	H
18	$\frac{3}{8}$	$\frac{5}{8}$	3	$1\frac{1}{4}$	$8\frac{3}{8}$	$6\frac{3}{8}$	$1\frac{1}{8}$
30	$\frac{1}{2}$	$\frac{3}{4}$	5	$1\frac{7}{8}$	$13\frac{3}{4}$	$10\frac{5}{8}$	$1\frac{3}{8}$
36	$\frac{5}{8}$	$\frac{7}{8}$	6	$2\frac{1}{4}$	$16\frac{1}{2}$	$12\frac{3}{4}$	$1\frac{5}{8}$
48	$\frac{3}{4}$	$1\frac{1}{4}$	8	3	22	17	$2\frac{1}{4}$

W2-4 CODE	
18"	
30"	020243
36"	020244
48"	020245

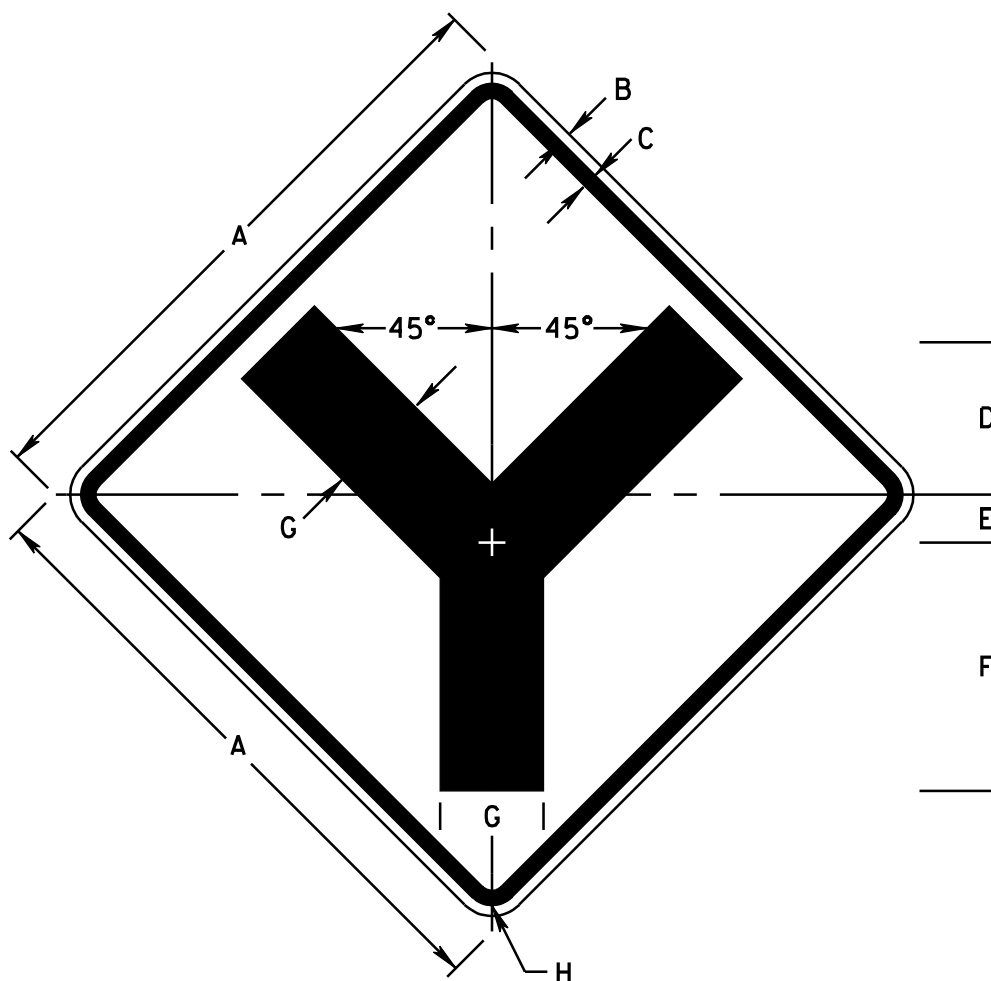

**COLORS**

LEGEND - BLACK (NON-REF)

BACKGROUND - YELLOW (REF)

DIMENSIONS (INCHES)

A	B	C	D	E	F	G	H
18	$\frac{3}{8}$	$\frac{5}{8}$	$4\frac{1}{2}$	$1\frac{3}{4}$	$6\frac{3}{4}$	3	$1\frac{1}{8}$
30	$\frac{1}{2}$	$\frac{3}{4}$	$7\frac{3}{8}$	3	$11\frac{3}{8}$	5	$1\frac{3}{8}$
36	$\frac{5}{8}$	$\frac{7}{8}$	$8\frac{7}{8}$	$3\frac{5}{8}$	$13\frac{5}{8}$	6	$1\frac{5}{8}$
48	$\frac{3}{4}$	$1\frac{1}{4}$	$11\frac{13}{16}$	$4\frac{13}{16}$	$18\frac{3}{16}$	8	$2\frac{1}{4}$

W2-5 CODE	
18"	
30"	020249
36"	020250
48"	020251



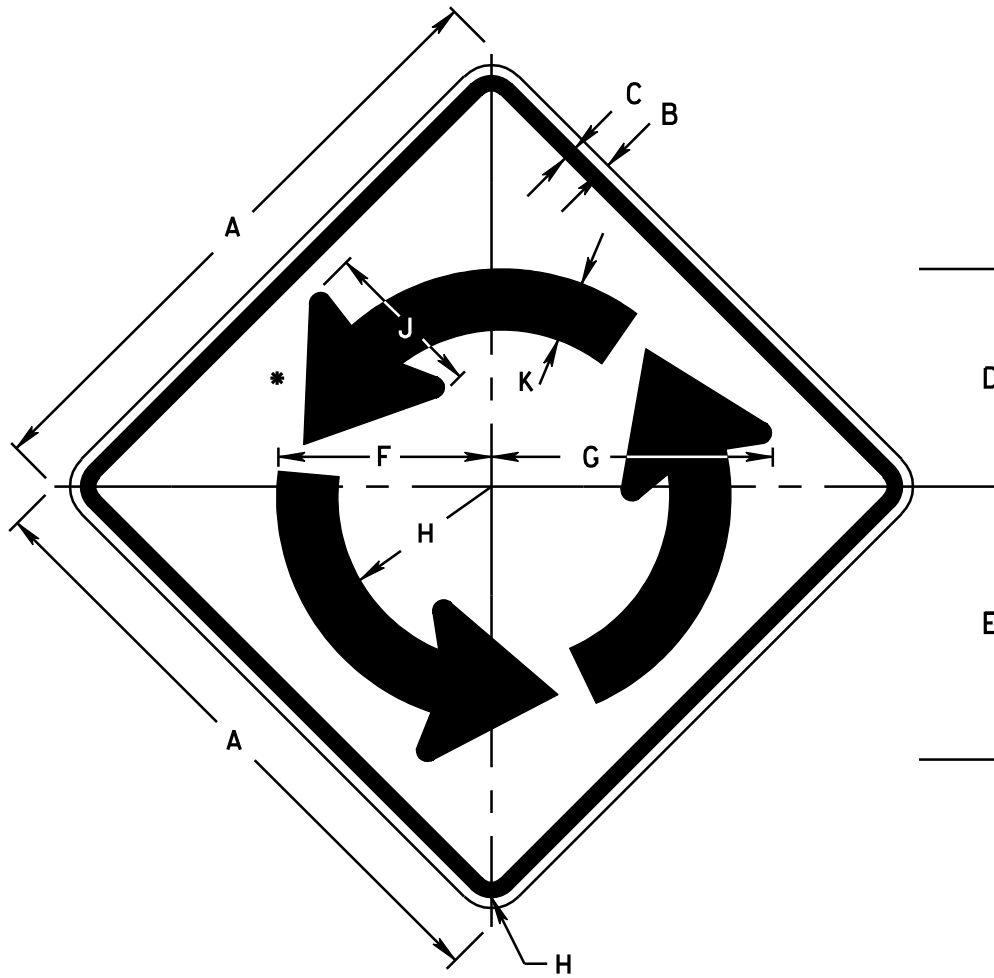

COLORS  
 LEGEND - BLACK (NON-REF)  
 BACKGROUND - YELLOW (REF)

DIMENSIONS (INCHES)

A	B	C	D	E	F	G	H	J	K	H
30	1/2	3/4	10 1/2	13 1/2	10 1/2	13 9/16	7 1/2	7 3/4	2 15/16	1 3/8
36	5/8	7/8	12 5/8	16 3/16	12 5/8	16 5/16	9	9 1/4	3 9/16	1 5/8
48	3/4	1 1/4	16 13/16	21 5/8	16 13/16	21 11/16	12	12 3/8	4 3/4	2 1/4

\* - SEE APPENDIX FOR SYMBOL DESIGN

W2-6 CODE	
30"	
36"	
48"	

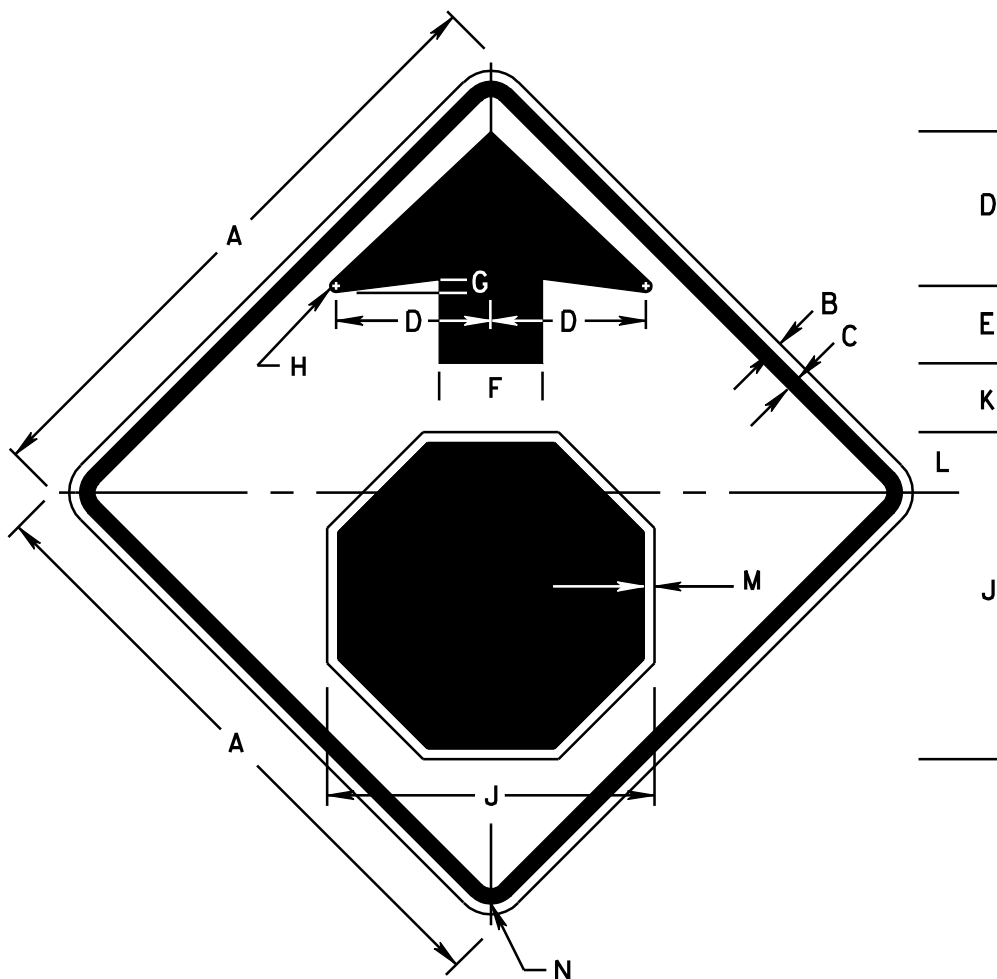

**COLORS**

BORDER AND ARROW - BLACK (NON-REF)  
 SYMBOL - WHITE BORDER ON RED BACKGROUND (REF)  
 BACKGROUND - YELLOW (REF)

**DIMENSIONS (INCHES)**

A	B	C	D	E	F	G	H	J	K	L	M	N
18	3/8	5/8	4 1/2	2 1/4	3	3/8	3/16	9 1/2	2	1 3/4	3/8	1 1/8
30	1/2	3/4	7 1/2	3 3/4	5	5/8	5/16	15 3/4	3 3/8	2 7/8	1/2	1 3/8
36	5/8	7/8	9	4 1/2	6	3/4	3/8	19	4	3 1/2	5/8	1 5/8
48	3/4	1 1/4	12	6	8	1	1/2	25 1/8	5 1/2	4 1/2	3/4	2 1/4

18" SIZE FOR USE ON BIKE ROUTES ONLY.

WHEN USED IN CONSTRUCTION OR MAINTENANCE OPERATIONS  
 THE SIGN SHALL HAVE AN ORANGE REFLECTIVE BACKGROUND,  
 AND SHALL HAVE THE SUFFIX "M" ADDED TO THE FABRICATION NUMBER.

W3-1 CODE	W3-1M CODE
18"	18"
30"	30"
36"	020301 36"
48"	020302 48"

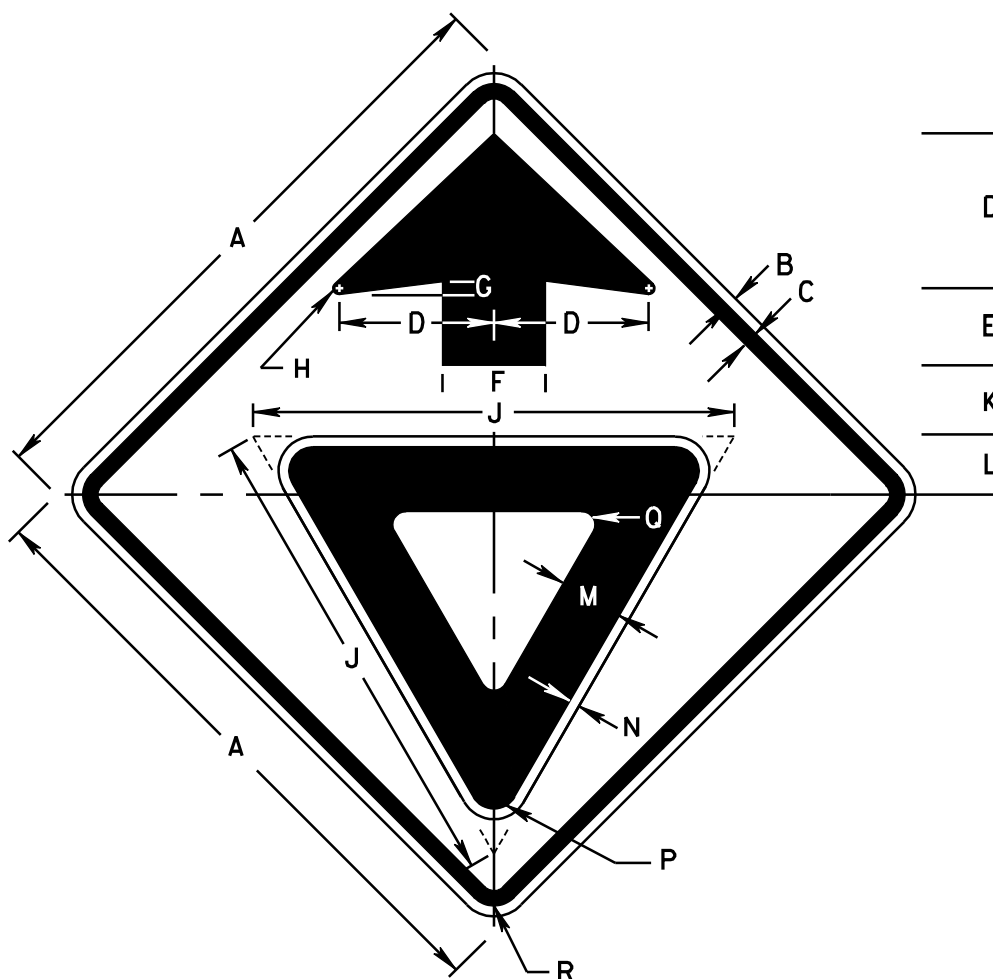

**COLORS**

BORDER AND ARROW - BLACK (NON-REF)  
 SYMBOL - WHITE BORDER ON RED BACKGROUND (REF)  
 BACKGROUND - YELLOW (REF)

**DIMENSIONS (INCHES)**

A	B	C	D	E	F	G	H	J	K	L	M	N	P	Q	R
18	3/8	5/8	4 1/2	2 1/4	3	3/8	3/16	14	2 1/16	1 1/16	1 7/8	5/16	1/16	3/8	1 1/8
30	1/2	3/4	7 1/2	3 3/4	5	5/8	5/16	25	3 1/4	3	3 3/8	1/2	1 1/4	5/8	1 3/8
36	5/8	7/8	9	4 1/2	6	3/4	3/8	28	4 1/8	3 3/8	3 3/4	5/8	1 3/8	3/4	1 5/8
48	3/4	1 1/4	12	6	8	1	1/2	38	5 1/2	4 1/2	5	3/4	1 7/8	1	2 1/4

18" SIZE FOR USE ON BIKE ROUTES ONLY.

WHEN USED IN CONSTRUCTION OR MAINTENANCE OPERATIONS  
 THE SIGN SHALL HAVE AN ORANGE REFLECTIVE BACKGROUND,  
 AND SHALL HAVE THE SUFFIX "M" ADDED TO THE FABRICATION NUMBER.

WV DEPARTMENT OF TRANSPORTATION  
 DIVISION OF HIGHWAYS  
 TRAFFIC ENGINEERING DIVISION

W3-2 CODE	W3-2M CODE
18"	18"
30"	30"
36" 020315	36"
48" 020316	48"

**W3-2**

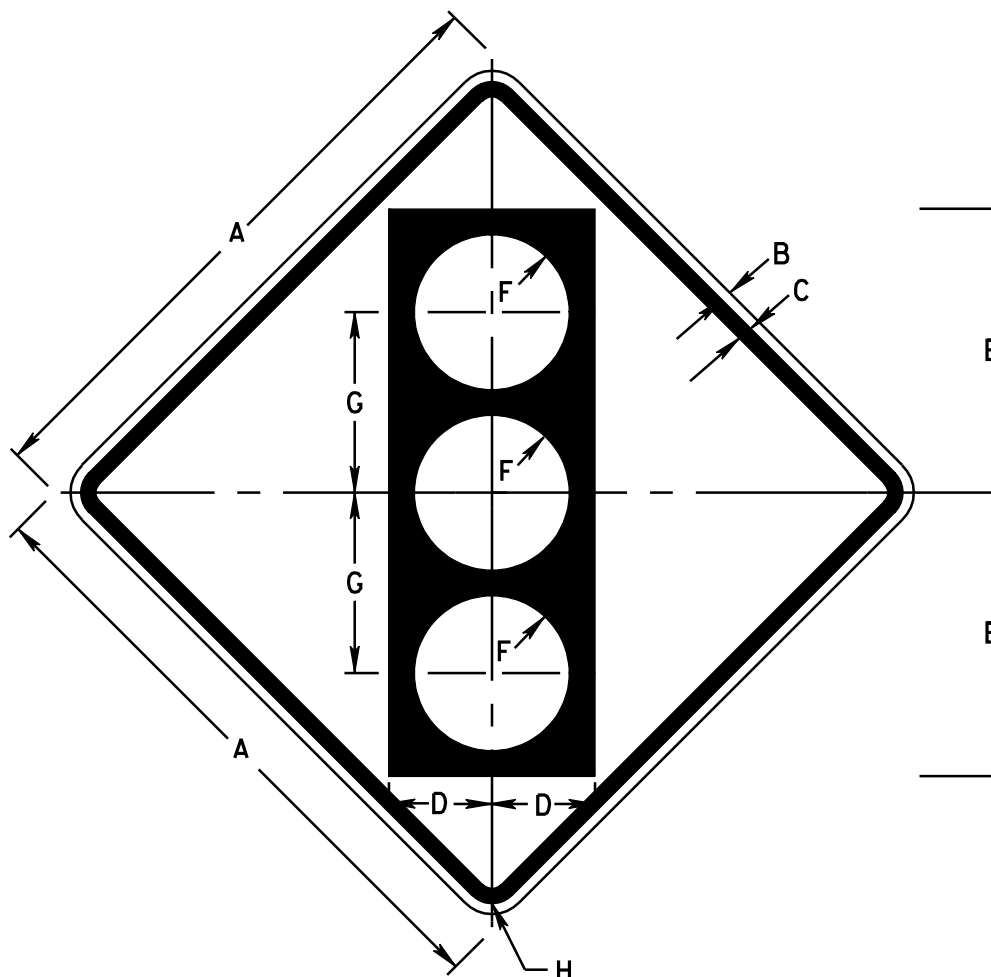

COLORS

- SYMBOL & LEGEND - BLACK (NON-REF)
- TOP CIRCLE - RED (REF)
- BOTTOM CIRCLE - GREEN (REF)
- BACKGROUND - YELLOW (REF)

DIMENSIONS (INCHES)

A	B	C	D	E	F	G	H
30	1/2	3/4	5	13 3/4	3 3/4	8 3/4	1 3/8
36	5/8	7/8	5 3/4	15 3/4	4 1/4	10	1 5/8
48	3/4	1 1/4	7 1/2	20	5	12 1/2	2 1/4

WHEN USED IN CONSTRUCTION OR MAINTENANCE OPERATIONS  
 THE SIGN SHALL HAVE AN ORANGE REFLECTIVE BACKGROUND,  
 AND SHALL HAVE THE SUFFIX "M" ADDED TO THE FABRICATION NUMBER.

W3-3 CODE		W3-3M CODE	
30"		30"	
36"	020329	36"	
48"	020330	48"	

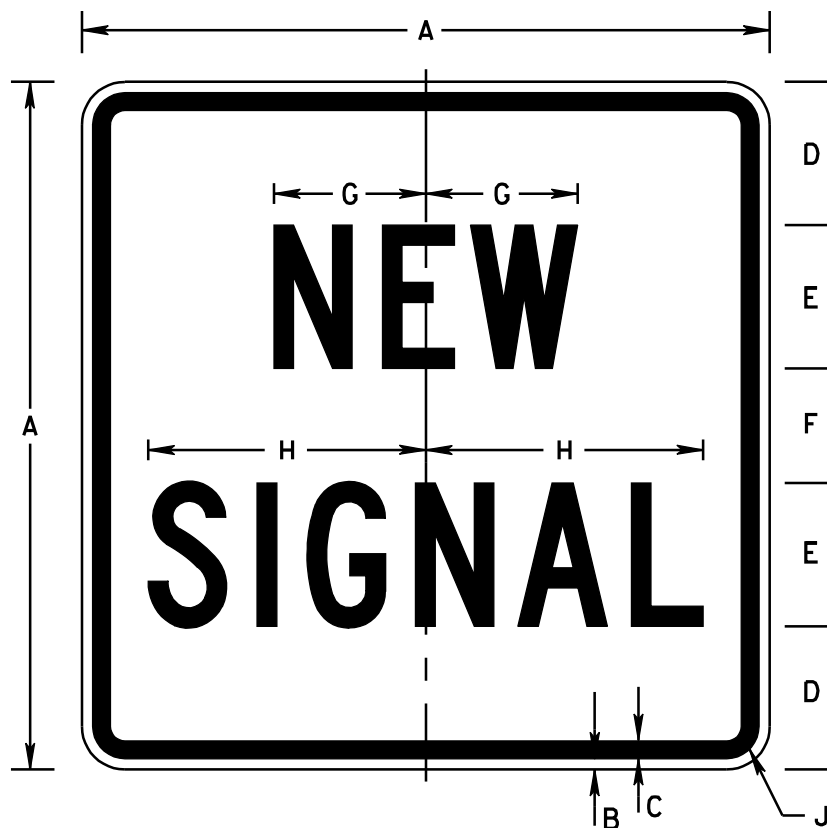

COLORS

LEGEND - BLACK (NON-REF)  
 BACKGROUND - YELLOW (REF)

DIMENSIONS (INCHES)

A	B	C	D	E	F	G	H	J
24	3/8	5/8	5	5C	4	5 5/16	9 11/16	1 1/8

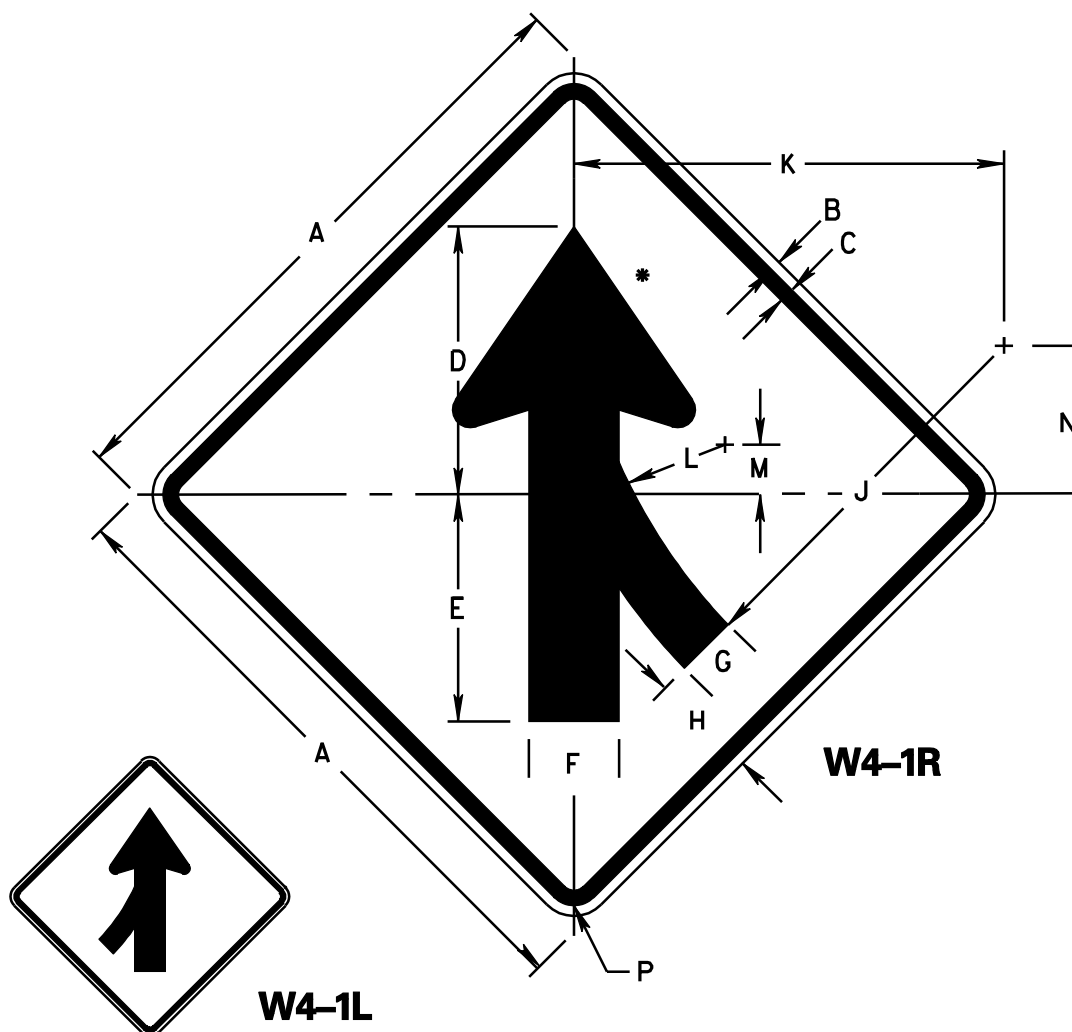

**W4-1R**

**W4-1L**

**COLORS**  
 LEGEND - (NON-REF)  
 BACKGROUND - YELLOW (REF)

**DIMENSIONS (INCHES)**

A	B	C	D	E	F	G	H	J	K	L	M	N	P
24	$\frac{3}{8}$	$\frac{5}{8}$	$10\frac{1}{4}$	$8\frac{3}{4}$	$3\frac{1}{2}$	$2\frac{3}{8}$	$4\frac{3}{16}$	$22\frac{1}{4}$	$22\frac{3}{16}$	$6\frac{3}{8}$	$2\frac{5}{8}$	$10\frac{3}{8}$	$1\frac{1}{8}$
30	$\frac{1}{2}$	$\frac{3}{4}$	13	11	$4\frac{3}{8}$	3	$5\frac{1}{4}$	28	$27\frac{3}{4}$	8	3	13	$1\frac{3}{8}$
36	$\frac{5}{8}$	$\frac{7}{8}$	$15\frac{3}{4}$	$13\frac{1}{4}$	$5\frac{1}{4}$	$3\frac{5}{8}$	$6\frac{5}{16}$	$33\frac{5}{8}$	$33\frac{5}{16}$	$9\frac{5}{8}$	4	$15\frac{5}{8}$	$1\frac{5}{8}$
48	$\frac{3}{4}$	$1\frac{1}{4}$	$20\frac{1}{2}$	$17\frac{1}{2}$	7	$4\frac{3}{4}$	$8\frac{3}{8}$	45	$44\frac{3}{8}$	$12\frac{13}{16}$	$5\frac{1}{4}$	$20\frac{3}{4}$	$2\frac{1}{4}$

\* - SEE APPENDIX FOR ARROW DESIGN

48" - WHEN USED IN CONSTRUCTION OR MAINTENANCE OPERATIONS  
 THE SIGN SHALL HAVE AN ORANGE REFLECTIVE BACKGROUND,  
 AND SHALL HAVE THE SUFFIX "M" ADDED TO THE FABRICATION NUMBER.

WV DEPARTMENT OF TRANSPORTATION  
 DIVISION OF HIGHWAYS  
 TRAFFIC ENGINEERING DIVISION

W4-1R CODE	W4-1L CODE
24"	24"
30"	30"
36"	020401 36"
48"	020402 48"
48"-M	48"-M

**W4-1**

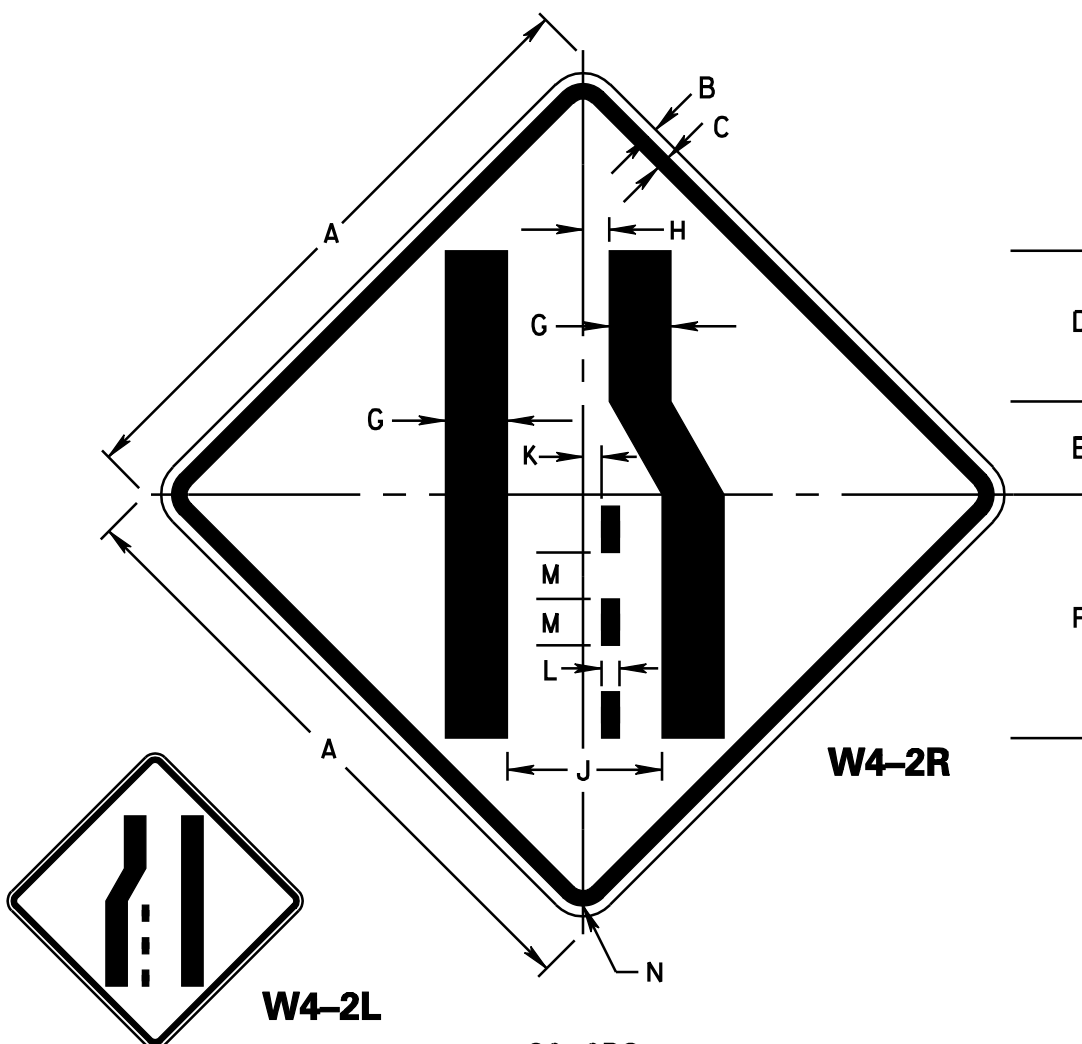

**COLORS**

LEGEND - BLACK (NON-REF)  
 BACKGROUND - YELLOW (REF)

**DIMENSIONS (INCHES)**

A	B	C	D	E	F	G	H	J	K	L	M	N
30	1/2	3/4	7 5/16	4 1/2	11 13/16	3	1 3/16	7 1/2	1 1/16	7/8	2 1/4	1 3/8
36	5/8	7/8	8 3/4	5 3/8	14 3/16	3 5/8	1 1/2	9	1 1/16	1 1/16	2 11/16	1 5/8
48	3/4	1 1/4	11 11/16	7 3/16	18 7/8	4 13/16	2 1/16	12	1 1/2	1 3/8	3 5/8	2 1/4

WHEN USED IN CONSTRUCTION OR MAINTENANCE OPERATIONS  
 THE SIGN SHALL HAVE AN ORANGE REFLECTIVE BACKGROUND,  
 AND SHALL HAVE THE SUFFIX "M" ADDED TO THE FABRICATION NUMBER.

WV DEPARTMENT OF TRANSPORTATION  
 DIVISION OF HIGHWAYS  
 TRAFFIC ENGINEERING DIVISION

W4-2R CODE	W4-2L CODE
30"	30"
36" 020408	36" 020418
48" 020409	48" 020419
30" M	30" M
36" M	36" M
48" M 020411	48" M 020421

**W4-2**

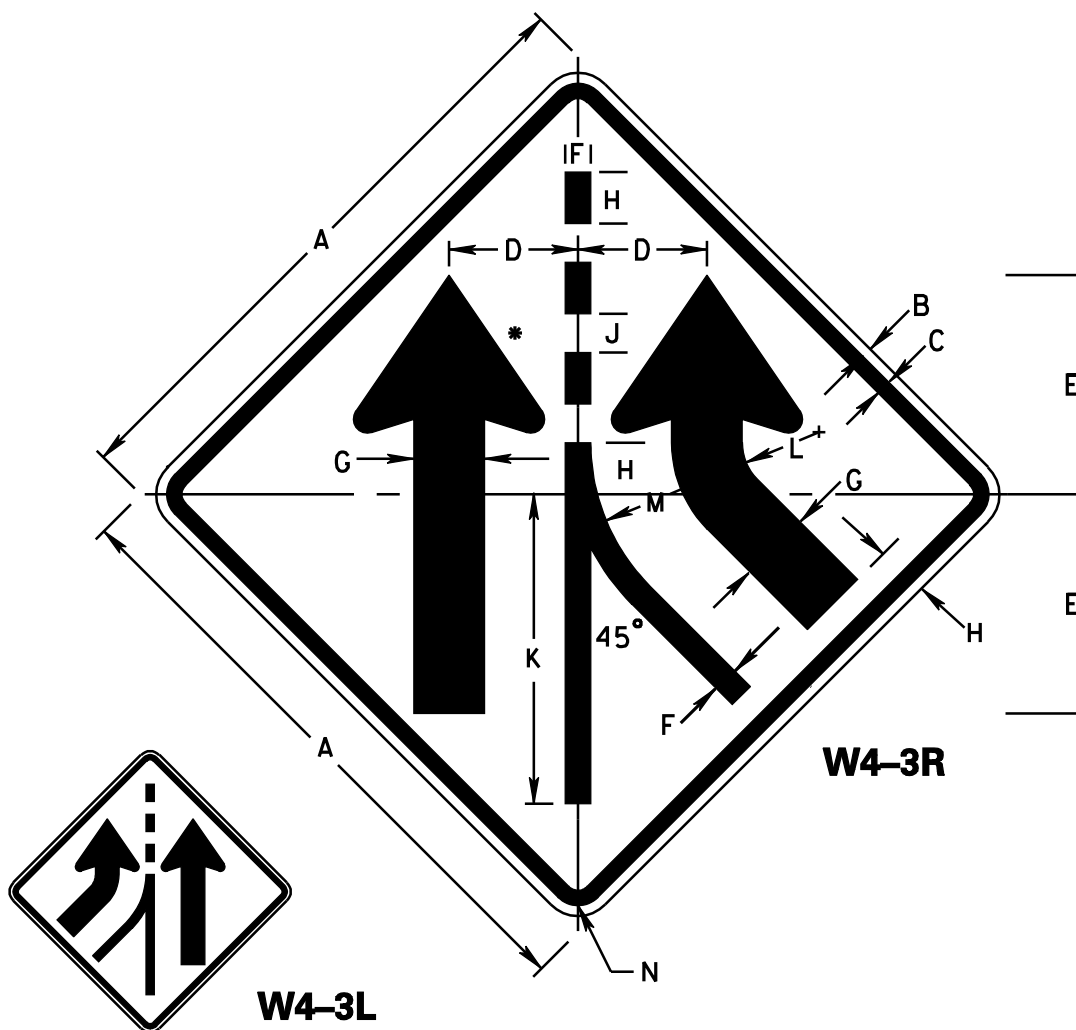

**COLORS**  
 LEGEND - BLACK (NON-REF)  
 BACKGROUND - YELLOW (REF)

**DIMENSIONS (INCHES)**

A	B	C	D	E	F	G	H	J	K	L	M	N
48	3/4	1 1/4	10	17	2	5 1/2	4	3	24	4	15 3/4	2 1/4

\* - SEE APPENDIX FOR ARROW DESIGN  
 WHEN USED IN CONSTRUCTION OR MAINTENANCE OPERATIONS  
 THE SIGN SHALL HAVE AN ORANGE REFLECTIVE BACKGROUND,  
 AND SHALL HAVE THE SUFFIX "M" ADDED TO THE FABRICATION NUMBER.

W4-3R CODE	W4-3L CODE
48"	020430 48"
48"M	48"M



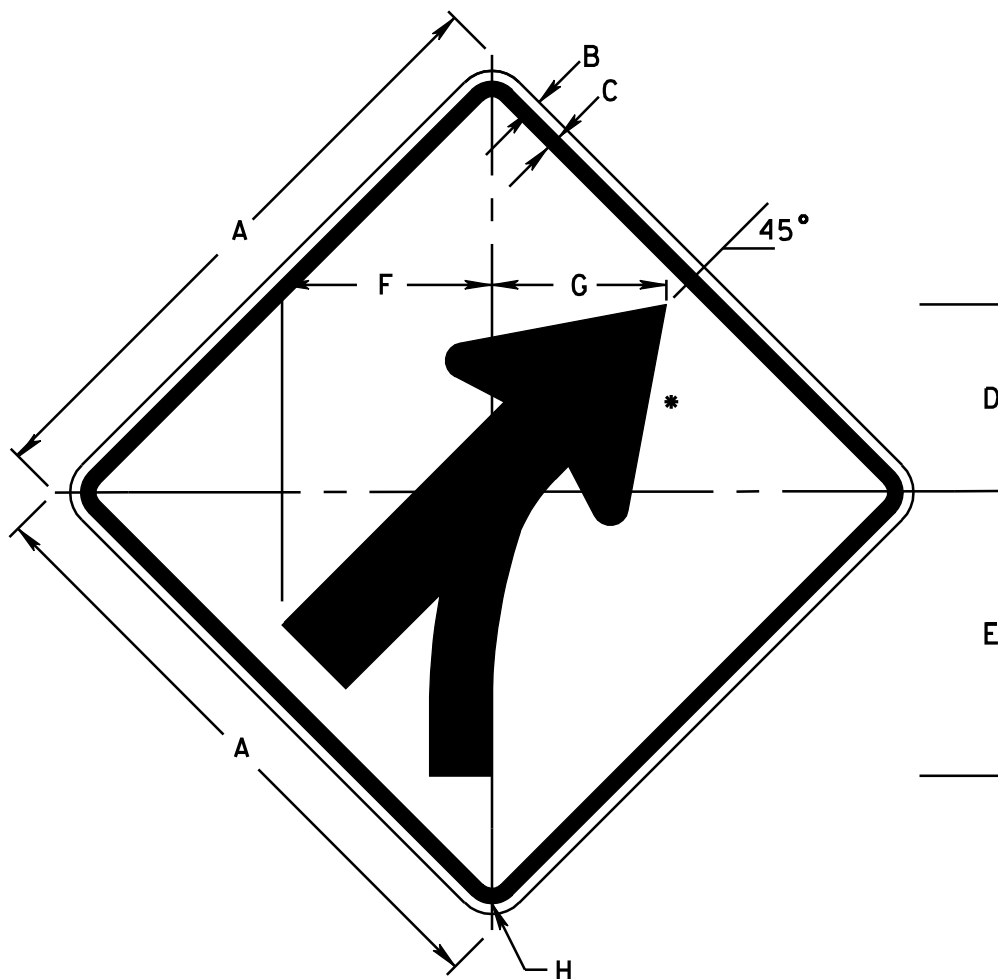

COLORS  
 LEGEND - (NON-REF)  
 BACKGROUND - YELLOW (REF)

DIMENSIONS (INCHES)

A	B	C	D	E	F	G	H
36	5/8	7/8	10 <sup>15</sup> / <sub>16</sub>	16 <sup>1</sup> / <sub>2</sub>	12 <sup>3</sup> / <sub>16</sub>	10 <sup>3</sup> / <sub>16</sub>	1 <sup>5</sup> / <sub>8</sub>
48	3/4	1 <sup>1</sup> / <sub>4</sub>	14 <sup>9</sup> / <sub>16</sub>	22	16 <sup>1</sup> / <sub>4</sub>	13 <sup>9</sup> / <sub>16</sub>	2 <sup>1</sup> / <sub>4</sub>

\* - SEE APPENDIX FOR ARROW DESIGN  
 SCALE AND ROTATE W4-1 TO FIT

W4-5R CODE	
36"	
48"	
48"-M	

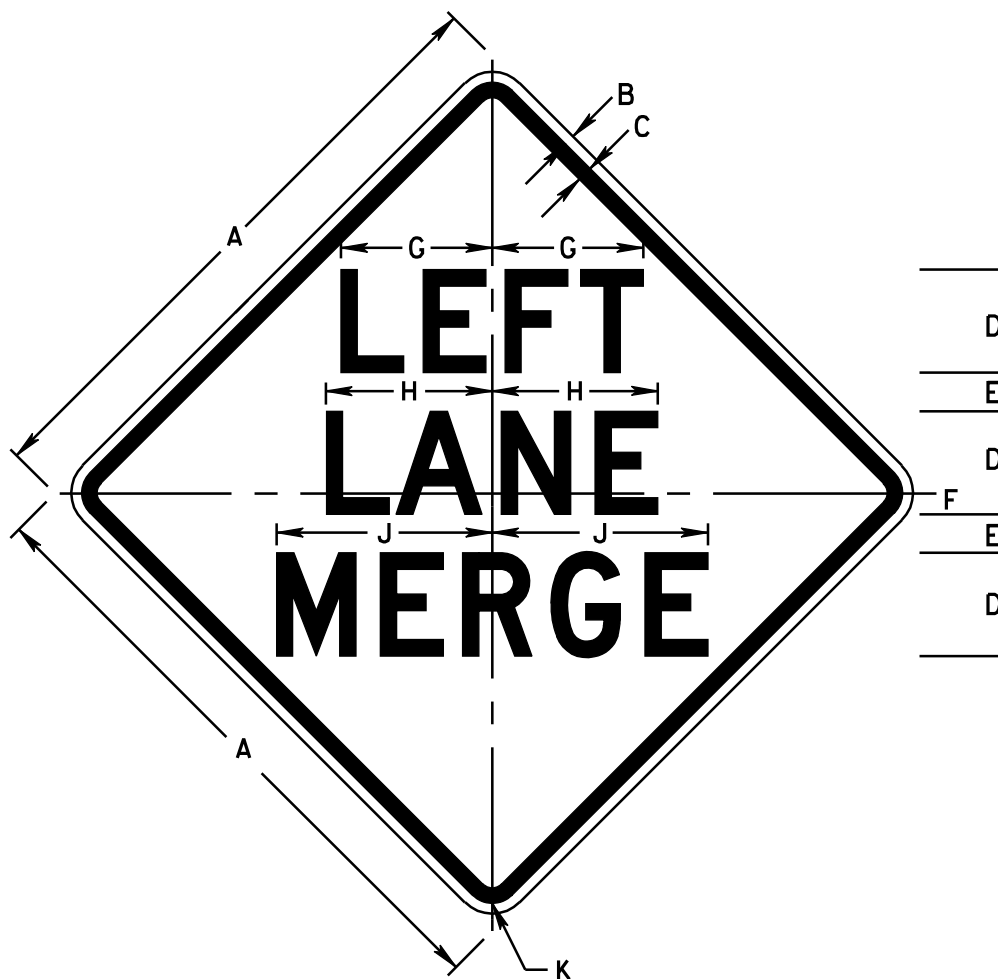

**COLORS**

LEGEND - BLACK (NON-REF)  
 BACKGROUND - YELLOW (REF)

**DIMENSIONS (INCHES)**

A	B	C	D	E	F	G	H	J	K
36	5/8	7/8	6D	2 1/4	1 1/4	8 13/16	9 5/8	12 9/16	1 5/8
48	3/4	1 1/4	8D	3	1 1/2	11 3/4	12 7/8	16 3/4	2 1/4

W4-5A CODE	
36"	
48"	
48"-M	

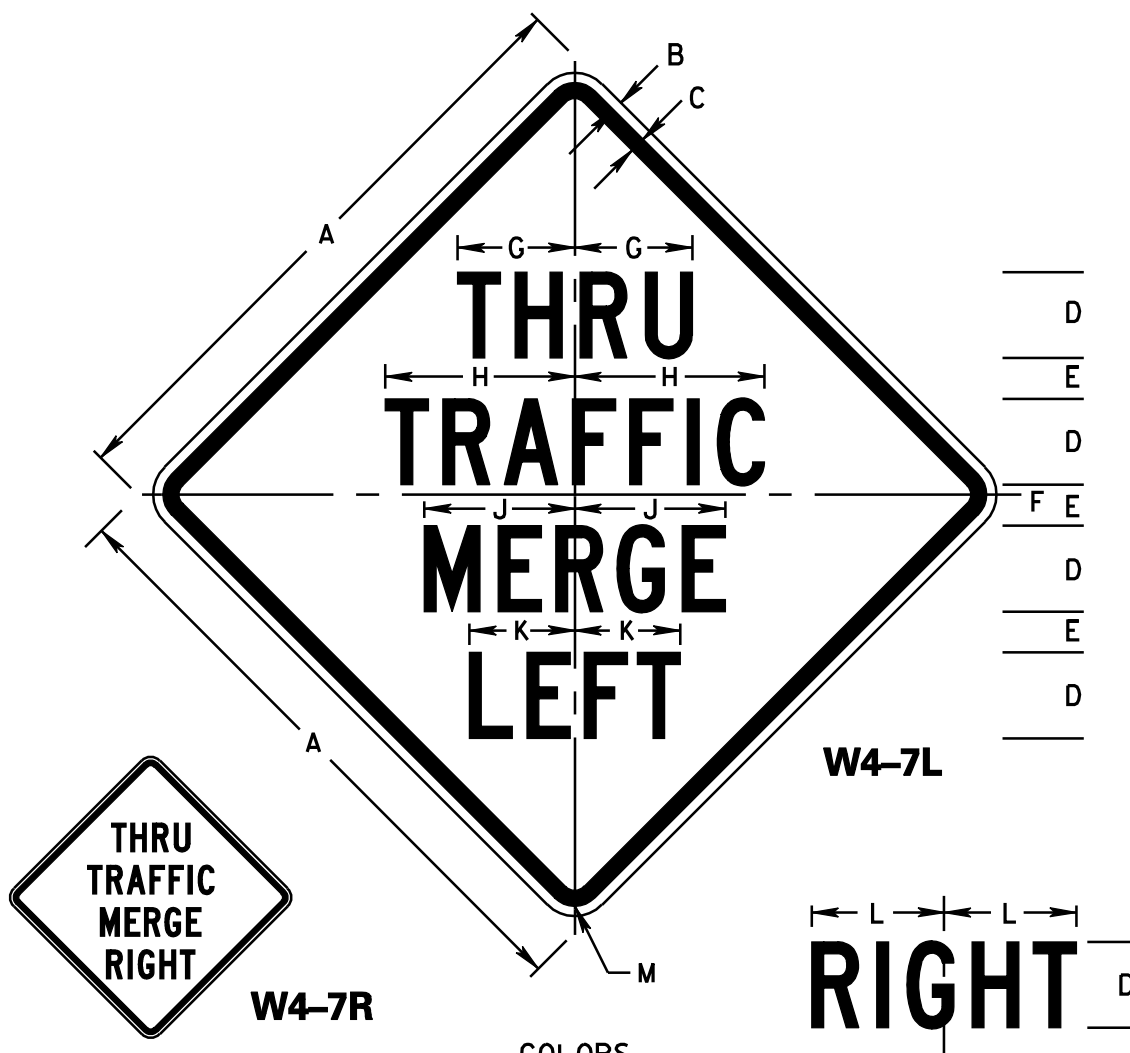

COLORS  
 LEGEND - BLACK (NON-REF)  
 BACKGROUND - YELLOW (REF)

DIMENSIONS (INCHES)

A	B	C	D	E	F	G	H	J	K	L	M
30	1/2	3/4	4C	2	1/2	5 3/8	8 1/2	7	4 3/4	6 1/8	1 3/8
36	5/8	7/8	5C	2 3/8	9/16	6 3/4	10 5/8	8 13/16	6	7 1/16	1 5/8
48	3/4	1 1/4	6C	3	11/16	8 1/8	12 3/4	10 9/16	7 3/16	9 1/4	2 1/4
60	1	1 1/2	8C	4	15/16	10 13/16	17	14 1/16	9 9/16	12 5/16	2 3/4

USAGE NOTE: REFER TO MUTCD 2003 SECTION 6F-23.  
 36" AND 48" - WHEN USED IN CONSTRUCTION OR MAINTENANCE OPERATIONS  
 THE SIGN SHALL HAVE AN ORANGE REFLECTIVE BACKGROUND,  
 AND SHALL HAVE THE SUFFIX "M" ADDED TO THE FABRICATION NUMBER.

WV DEPARTMENT OF TRANSPORTATION  
 DIVISION OF HIGHWAYS  
 TRAFFIC ENGINEERING DIVISION

W4-7R CODE	W4-7L CODE
30"	30"
36"	36"
48"	48"
60"	60"
36"M	36"M
48"M	48"M

**W4-7**

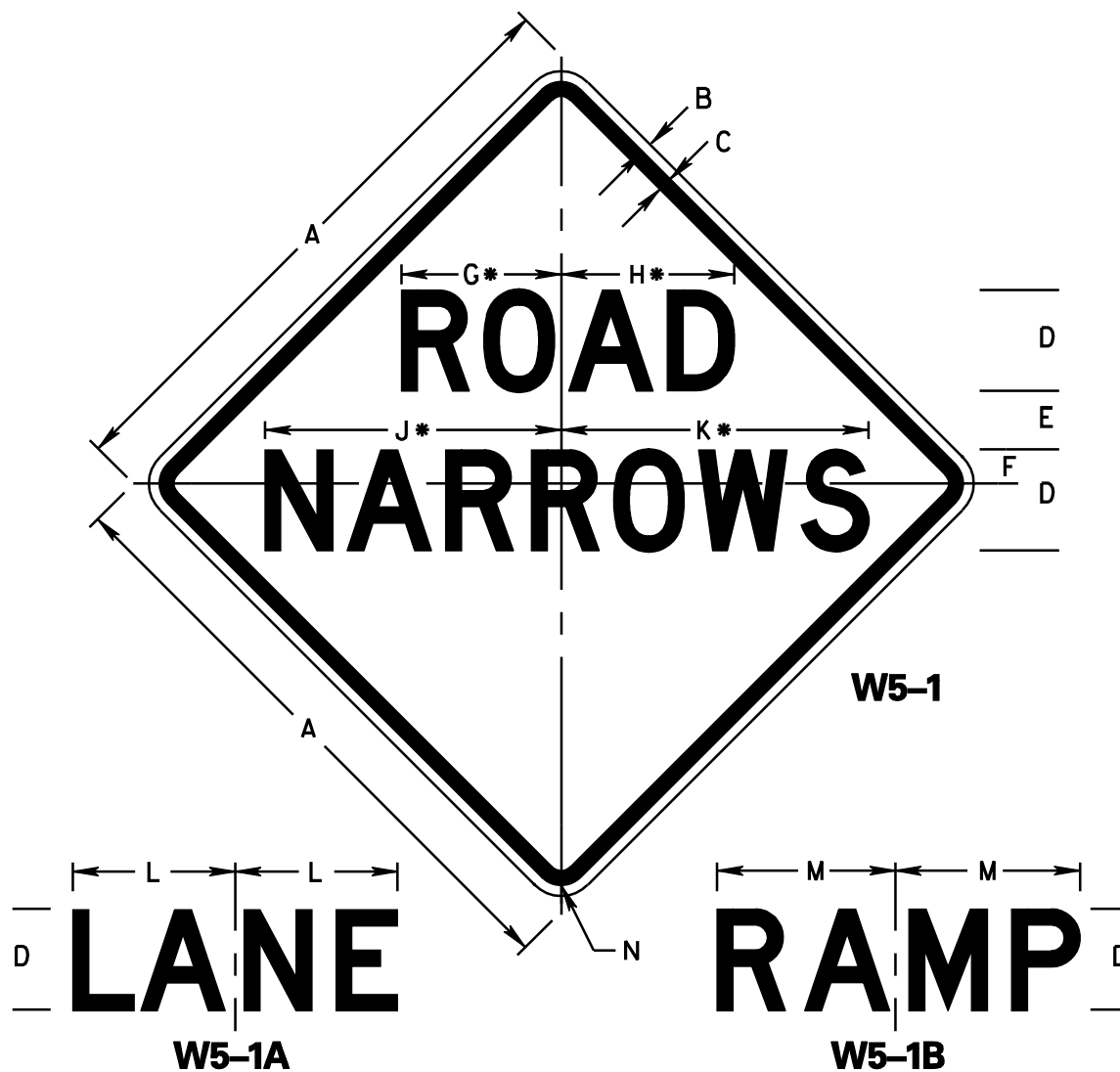

COLORS  
 LEGEND - BLACK (NON-REF)  
 BACKGROUND - YELLOW (REF)

DIMENSIONS (INCHES)

A	B	C	D	E	F	G	H	J	K	L	M	N
30	1/2	3/4	5D	3	1 3/4	7 7/8	8 5/8	14 3/4	15 1/8	8 1/16	8 15/16	1 3/8
36	5/8	7/8	6D	3 1/2	2	9 1/2	10 5/16	17 5/8	18 1/4	9 5/8	10 11/16	1 5/8
48	3/4	1 1/4	8D	4	3	12 11/16	13 3/4	23 1/2	24 3/8	12 7/8	14 1/4	2 1/4

\* - REDUCE SPACING 25%

WHEN USED IN CONSTRUCTION OR MAINTENANCE OPERATIONS  
 THE SIGN SHALL HAVE AN ORANGE REFLECTIVE BACKGROUND,  
 AND SHALL HAVE THE SUFFIX "M" ADDED TO THE FABRICATION NUMBER.

WV DEPARTMENT OF TRANSPORTATION  
 DIVISION OF HIGHWAYS  
 TRAFFIC ENGINEERING DIVISION

W5-1 CODE	W5-1A CODE	W5-1B CODE
30"	30"	30"
36" 020501	36"	36"
48"	48"	48"
30"-M	30"-M	30"-M
36"-M	36"-M	36"-M
48"-M	48"-M	48"-M

**W5-1**

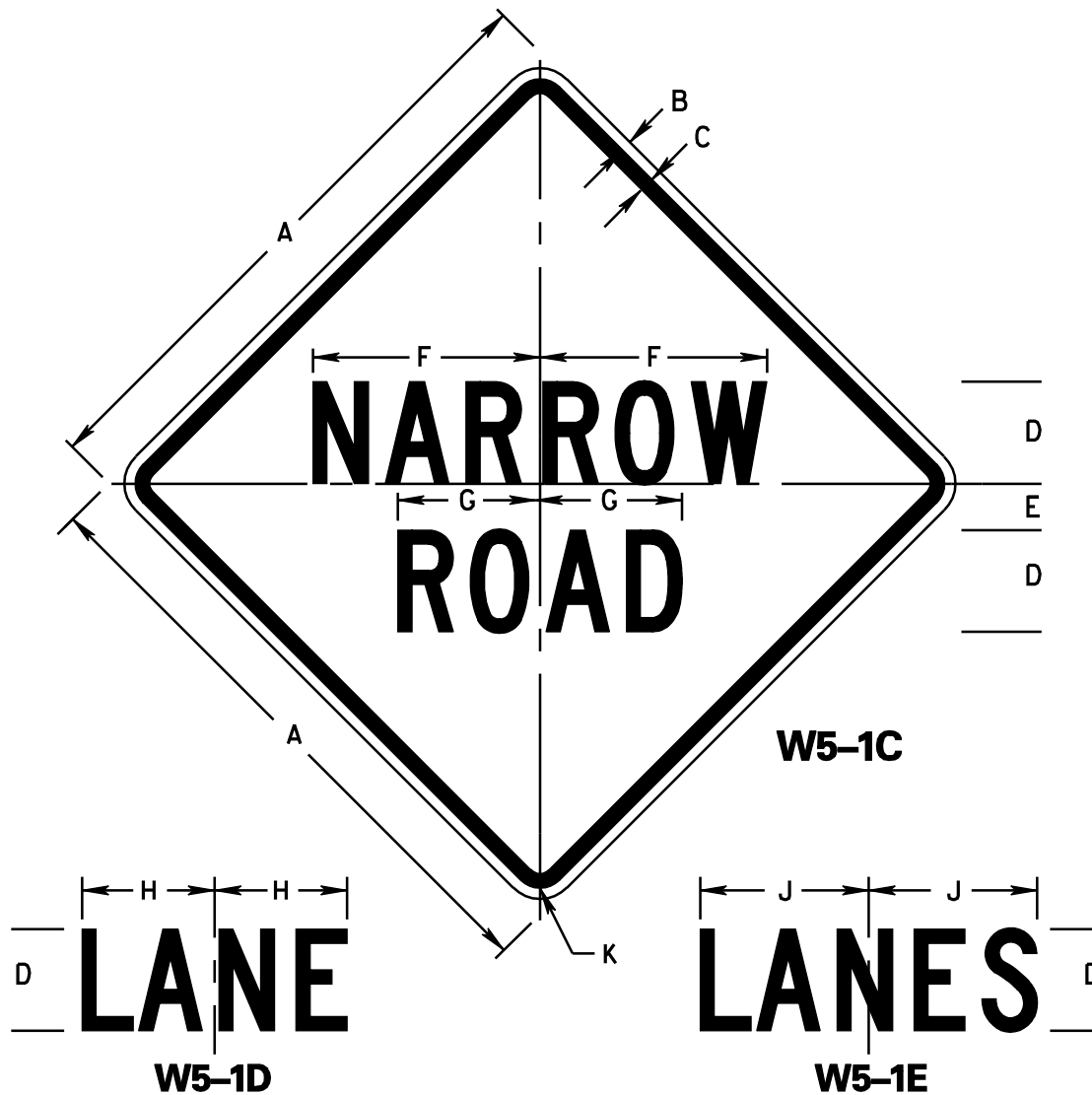

**COLORS**  
 LEGEND - BLACK (NON-REF)  
 BACKGROUND - YELLOW (REF)

**DIMENSIONS (INCHES)**

A	B	C	D	E	F	G	H	J	K
30	1/2	3/4	5C	2 1/4	1 1 3/16	7	6 1/2	8 9/16	1 3/8
36	5/8	7/8	6C	2 3/4	1 3 3/8	8 3/8	7 13/16	9 15/16	1 5/8

WHEN USED IN CONSTRUCTION OR MAINTENANCE OPERATIONS  
 THE SIGN SHALL HAVE AN ORANGE REFLECTIVE BACKGROUND,  
 AND SHALL HAVE THE SUFFIX "M" ADDED TO THE FABRICATION NUMBER.

WV DEPARTMENT OF TRANSPORTATION  
 DIVISION OF HIGHWAYS  
 TRAFFIC ENGINEERING DIVISION

W5-1C CODE	W5-1D CODE
30"	020539
36"	020505
30"M	
36"M	
W5-1E CODE	
30"	
36"	
30"M	
36"M	

**W5-1C**

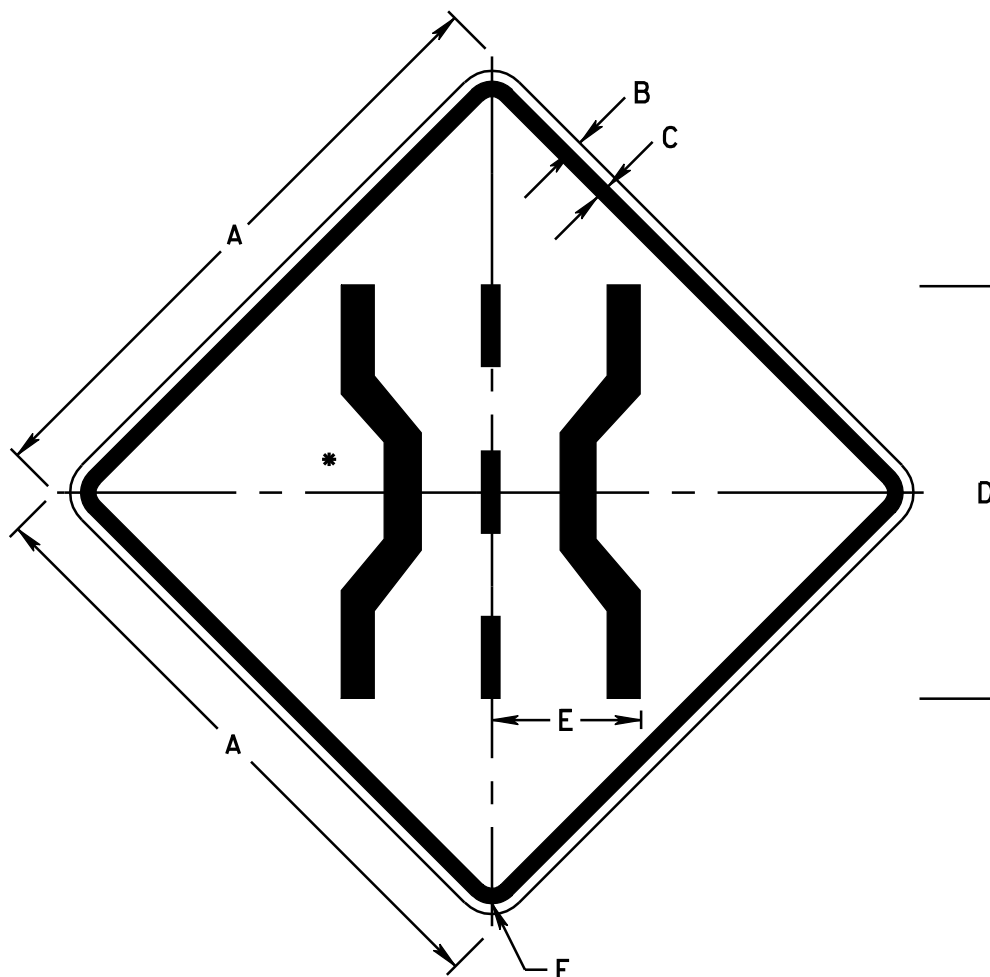

COLORS

LEGEND - BLACK (NON-REF)  
 BACKGROUND - YELLOW (REF)

DIMENSIONS (INCHES)

A	B	C	D	E	F
30	1/2	3/4	20	7 1/4	1 3/8
36	5/8	7/8	24	8 5/8	1 5/8
48	3/4	1 1/4	32	11 1/2	2 1/4

\* - SEE APPENDIX FOR SYMBOL DESIGN

48" AND 36" - WHEN USED IN CONSTRUCTION OR MAINTENANCE OPERATIONS  
 THE SIGN SHALL HAVE AN ORANGE REFLECTIVE BACKGROUND,  
 AND SHALL HAVE THE SUFFIX "M" ADDED TO THE FABRICATION NUMBER.

W5-2A CODE	W2-5AM CODE
30"	36"M
36" 020509	48"M
48" 020510	

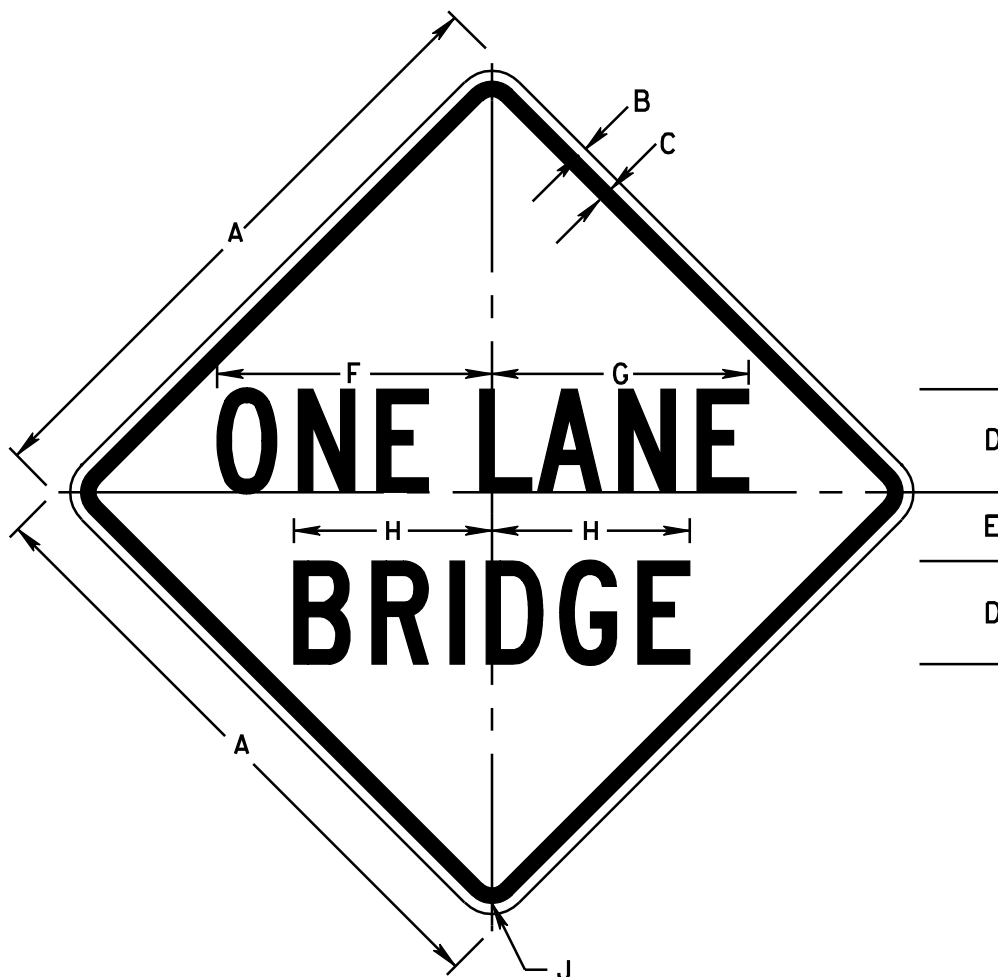

**COLORS**

LEGEND - BLACK (NON-REF)  
 BACKGROUND - YELLOW (REF)

**DIMENSIONS (INCHES)**

A	B	C	D	E	F	G	H	J
30	1/2	3/4	5C	3 1/4	13 5/16	12 11/16	9 1/8	1 3/8
36	5/8	7/8	6C	4	16	15 1/4	11 1/2	1 5/8
48	3/4	1 1/4	8C	5	21 1/4	20 1/4	15 3/8	2 1/4

\* - SEE APPENDIX FOR ARROW DESIGN

48" AND 36" - WHEN USED IN CONSTRUCTION OR MAINTENANCE OPERATIONS  
 THE SIGN SHALL HAVE AN ORANGE REFLECTIVE BACKGROUND,  
 AND SHALL HAVE THE SUFFIX "M" ADDED TO THE FABRICATION NUMBER.

W5-3 CODE		W5-3M CODE	
30"		36"M	
36"	020516	48"M	
48"	020517		

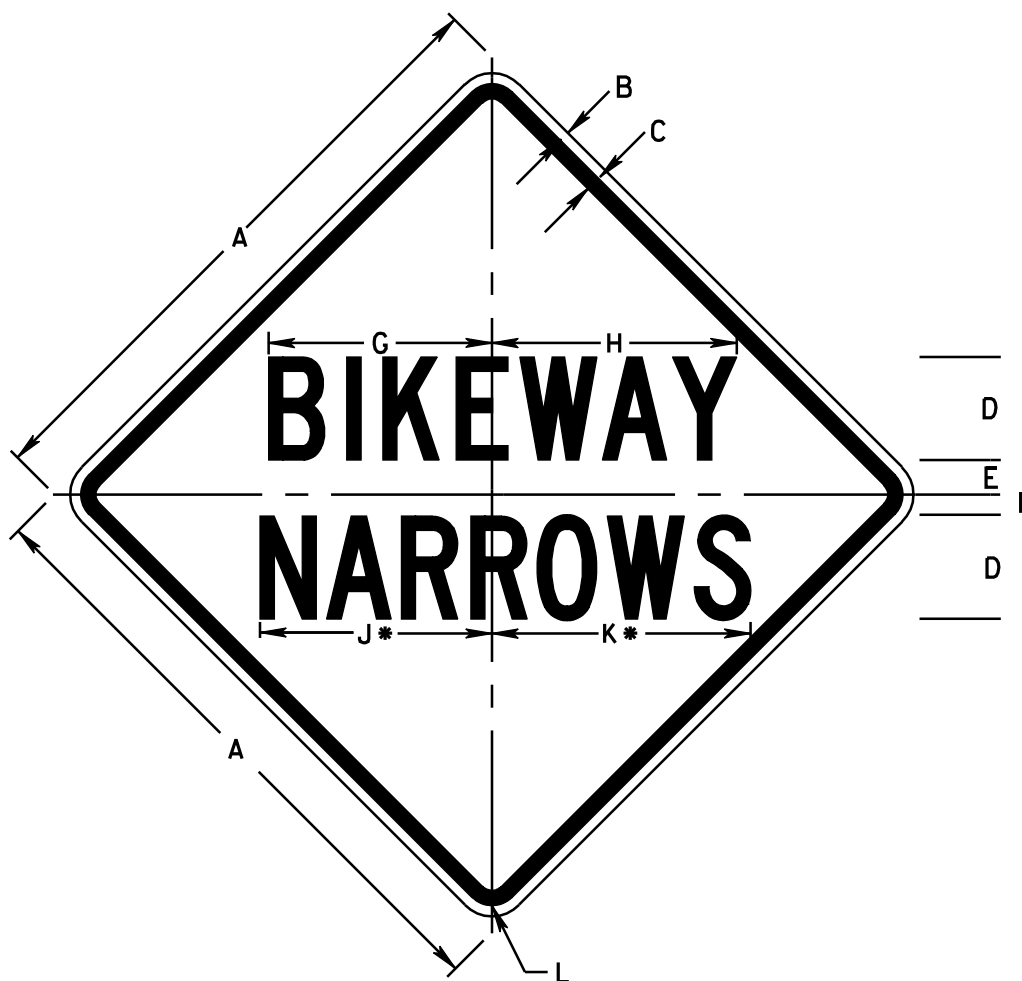

**COLORS**

LEGEND - BLACK (NON-REF)  
 BACKGROUND - YELLOW (REF)

**DIMENSIONS (INCHES)**

A	B	C	D	E	F	G	H	J	K	L
18	3/8	5/8	3C	1	5/8	6 1/2	7 1/8	6 3/4	7 1/2	1 1/8

\* - REDUCE SPACING 50%



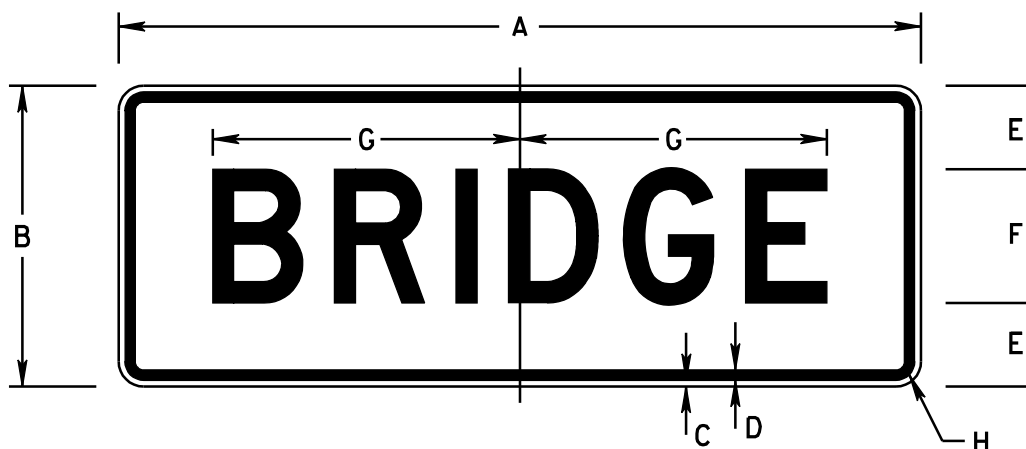

COLORS

LEGEND - BLACK (NON-REF)  
 BACKGROUND - YELLOW (REF)

DIMENSIONS (INCHES)

A	B	C	D	E	F	G	H
24	9	$\frac{3}{8}$	$\frac{3}{8}$	$2\frac{1}{2}$	4D	$9\frac{3}{16}$	$1\frac{1}{8}$
36	12	$\frac{3}{8}$	$\frac{3}{8}$	3	6D	$13\frac{3}{4}$	$1\frac{1}{8}$
48	18	$\frac{3}{8}$	$\frac{5}{8}$	5	8D	$18\frac{3}{8}$	$1\frac{1}{8}$

W5-5 CODE	
24 "x9 "	
36 "x12 "	
48 "x18 "	

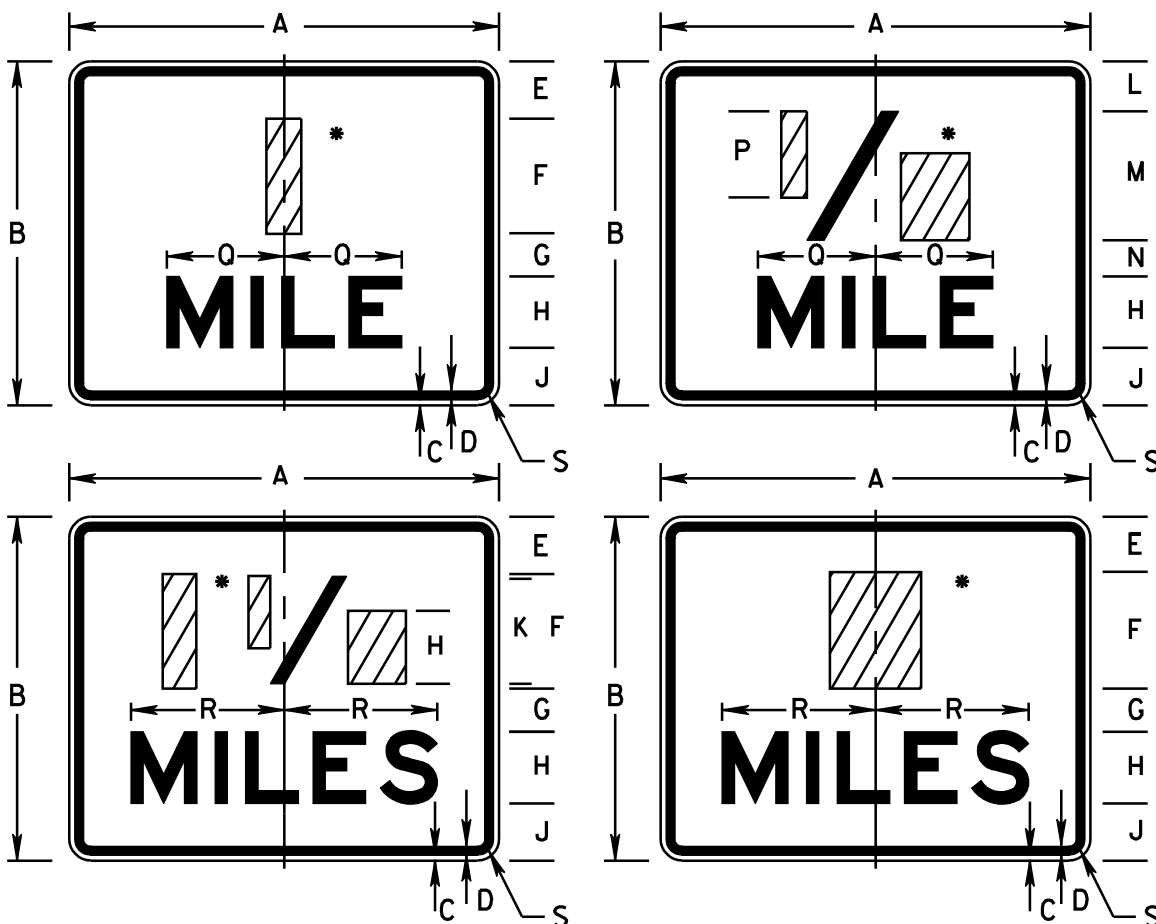

COLORS  
 LEGEND - BLACK (NON-REF)  
 BACKGROUND - YELLOW (REF)

DIMENSIONS (INCHES)

A	B	C	D	E	F	G	H	J	K	L	M	N	P	Q	R	S
24	18	3/8	5/8	2 11/16	6E	2 11/16	4E	2 5/8	6	1 15/16	7 1/2	1 15/16	5E	6 9/16	8 9/16	1 1/8
30	24	3/8	5/8	4	8E	3	5E	4	7 1/2	3 1/2	9	2 1/2	6E	8 3/16	10 3/4	1 1/8

\* - DISTANCES SHALL BE IN QUARTER MILE INCREMENTS BELOW 1 MILE  
 AND HALF MILE INCREMENTS AFTER THAT.

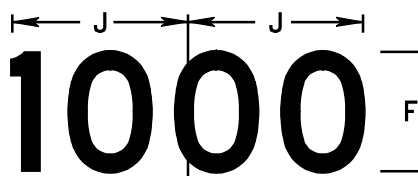
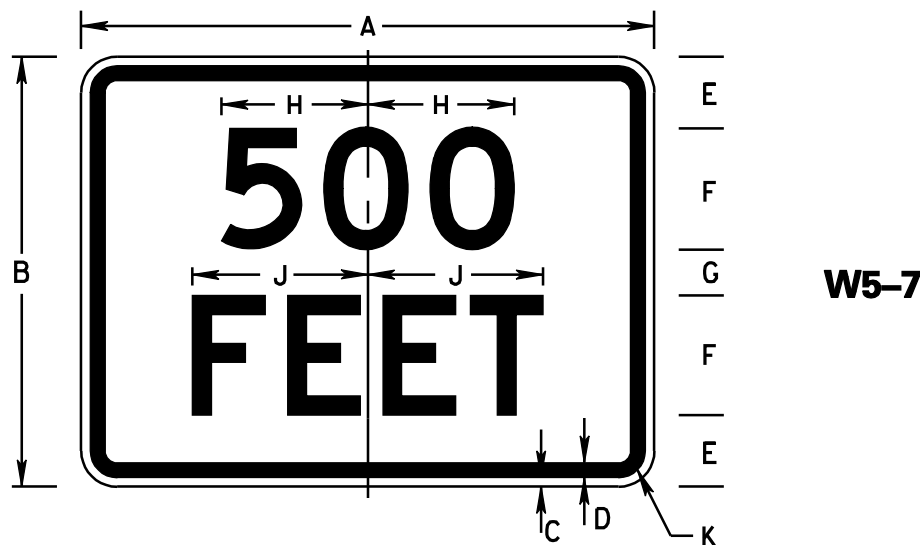

**W5-7A**

**COLORS**

LEGEND - BLACK (NON-REF)  
 BACKGROUND - YELLOW (REF)

**DIMENSIONS (INCHES)**

A	B	C	D	E	F	G	H	J	K
24	18	3/8	5/8	3	5D	2	6 3/6	7 3/8	1 1/8

WHEN USED IN CONSTRUCTION OR MAINTENANCE OPERATIONS  
 THE SIGN SHALL HAVE AN ORANGE REFLECTIVE BACKGROUND,  
 AND SHALL HAVE THE SUFFIX "M" ADDED TO THE FABRICATION NUMBER.

W5-7 CODE		W5-7A CODE	
24"x18"	020536	24"x18"	020536
W5-7M CODE		W5-7AM CODE	
24"x18"		24"x18"	

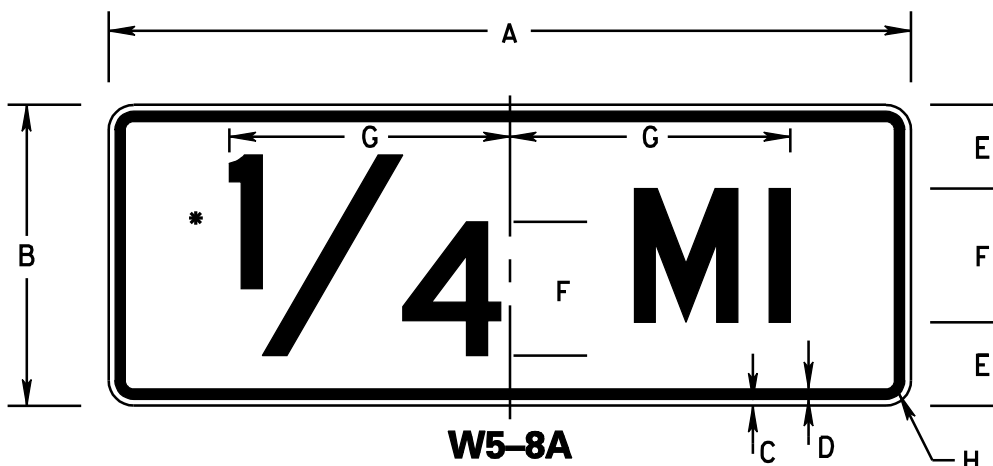

W5-8A

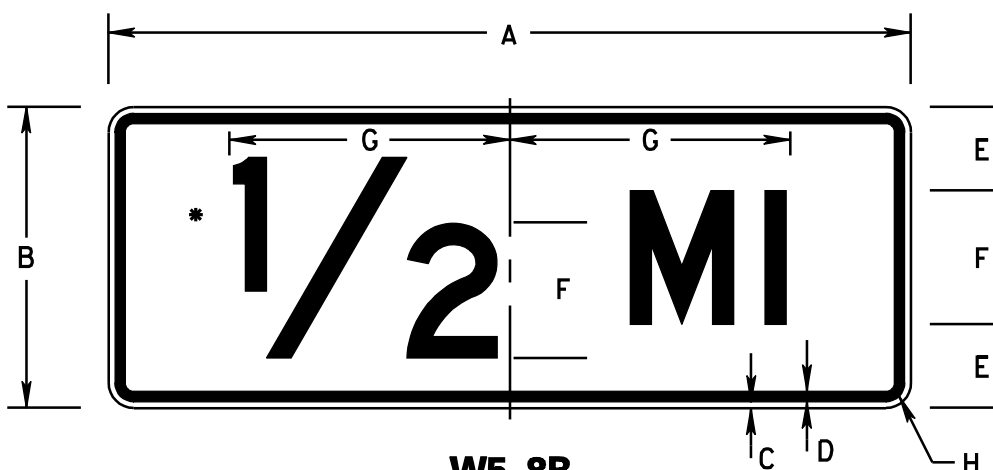

W5-8B

COLORS

LEGEND - BLACK (NON-REF)  
 BACKGROUND - YELLOW (REF)

DIMENSIONS (INCHES)

A	B	C	D	E	F	G	H
36	12	3/8	3/8	3	6D	12 9/16	1 1/8
48	18	3/8	5/8	3	8D	16 3/4	1 1/8

\* - SEE APPENDIX FOR FRACTION DETAIL  
 TO BE USED WITH SIGN R4-5A

W5-8A CODE	
36"x12"	
48"x18"	
W5-8B CODE	
36"x12"	
48"x18"	

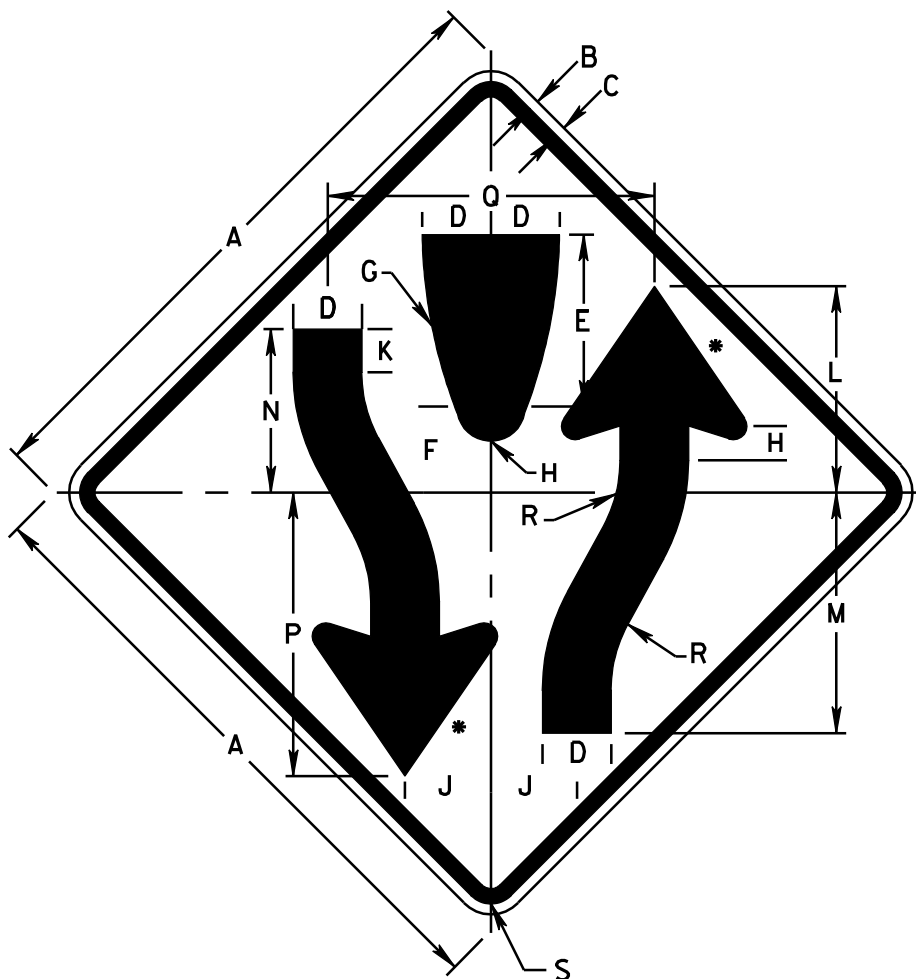

COLORS  
 LEGEND - BLACK (NON-REF)  
 BACKGROUND - YELLOW (REF)

DIMENSIONS (INCHES)

A	B	C	D	E	F	G	H	J	K	L	M	N	P	Q	R	S
30	1/2	3/4	3 5/16	8 5/16	4 1/8	25	1 1/16	4 1/8	2 1/16	10	11 5/8	7 15/16	13 11/16	15 3/4	9 3/32	1 3/8
36	5/8	7/8	4	10	5	30	2	5	2 1/2	12	14	9 1/2	16 1/2	19	12	1 5/8
48	3/4	1 1/4	5 1/4	13 1/8	6 9/16	39 5/16	2 5/8	6 9/16	3 5/16	16	18 11/16	12 11/16	22	24 7/8	15 3/4	2 1/4

\* - SEE APPENDIX FOR ARROW DESIGN

36" AND 48" - WHEN USED IN CONSTRUCTION OR MAINTENANCE OPERATIONS  
 THE SIGN SHALL HAVE AN ORANGE REFLECTIVE BACKGROUND,  
 AND SHALL HAVE THE SUFFIX "M" ADDED TO THE FABRICATION NUMBER.

W6-1 CODE	W6-1M CODE
30" 020601	36"
36" 020602	48"
48" 020603	

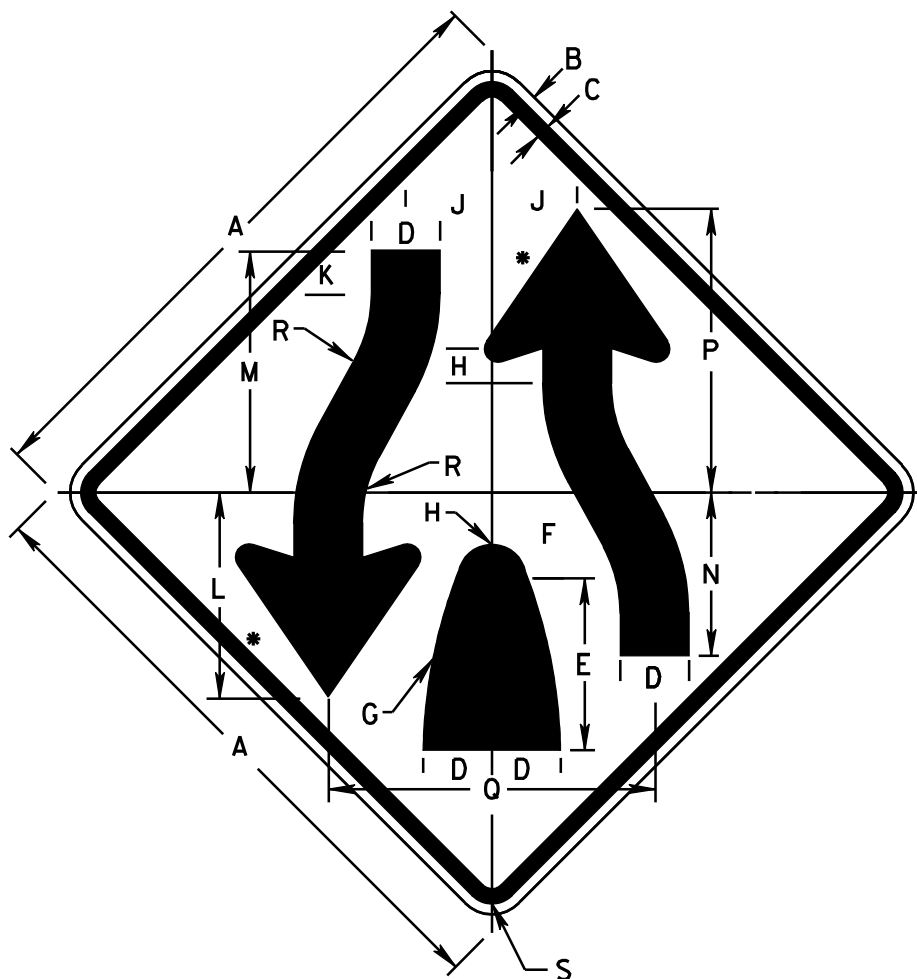

COLORS  
 LEGEND - BLACK (NON-REF)  
 BACKGROUND - YELLOW (REF)

DIMENSIONS (INCHES)

A	B	C	D	E	F	G	H	J	K	L	M	N	P	Q	R	S
30	1/2	3/4	3 5/16	8 5/16	4 1/8	25	1 11/16	4 1/8	2 1/16	10	11 5/8	7 15/16	13 11/16	15 3/4	9 3/32	1 3/8
36	5/8	7/8	4	10	5	30	2	5	2 1/2	12	14	9 1/2	16 1/2	19	12	1 5/8
48	3/4	1 1/4	5 1/4	13 1/8	6 9/16	39 5/16	2 5/8	6 9/16	3 5/16	16	18 11/16	12 11/16	22	24 7/8	15 3/4	2 1/4

\* - SEE APPENDIX FOR ARROW DESIGN

36" AND 48" - WHEN USED IN CONSTRUCTION OR MAINTENANCE OPERATIONS  
 THE SIGN SHALL HAVE AN ORANGE REFLECTIVE BACKGROUND,  
 AND SHALL HAVE THE SUFFIX "M" ADDED TO THE FABRICATION NUMBER.

W6-2 CODE	W6-2M CODE
30" 020609	36"
36" 020610	48"
48" 020611	

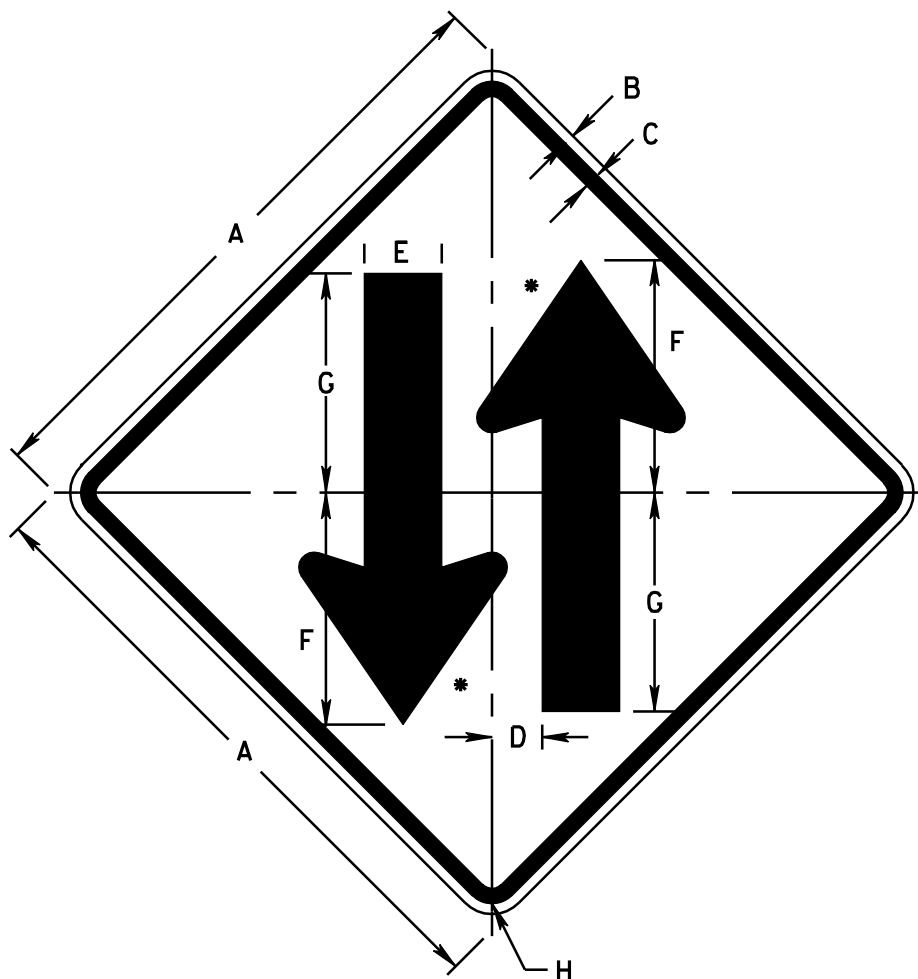

COLORS

LEGEND - BLACK (NON-REF)  
 BACKGROUND - YELLOW (REF)

DIMENSIONS (INCHES)

A	B	C	D	E	F	G	H
36	$\frac{5}{8}$	$\frac{7}{8}$	$2\frac{15}{16}$	$4\frac{1}{2}$	$13\frac{1}{2}$	$12\frac{3}{4}$	$1\frac{5}{8}$
48	$\frac{3}{4}$	$1\frac{1}{4}$	$3\frac{7}{8}$	6	18	17	$2\frac{1}{4}$

\* - SEE APPENDIX FOR ARROW DESIGN  
 WHEN USED IN CONSTRUCTION OR MAINTENANCE OPERATIONS  
 THE SIGN SHALL HAVE AN ORANGE REFLECTIVE BACKGROUND,  
 AND SHALL HAVE THE SUFFIX "M" ADDED TO THE FABRICATION NUMBER.

W6-3 CODE	W6-3M CODE
36" 020618	36" 020618
48" 020619	48" 020620

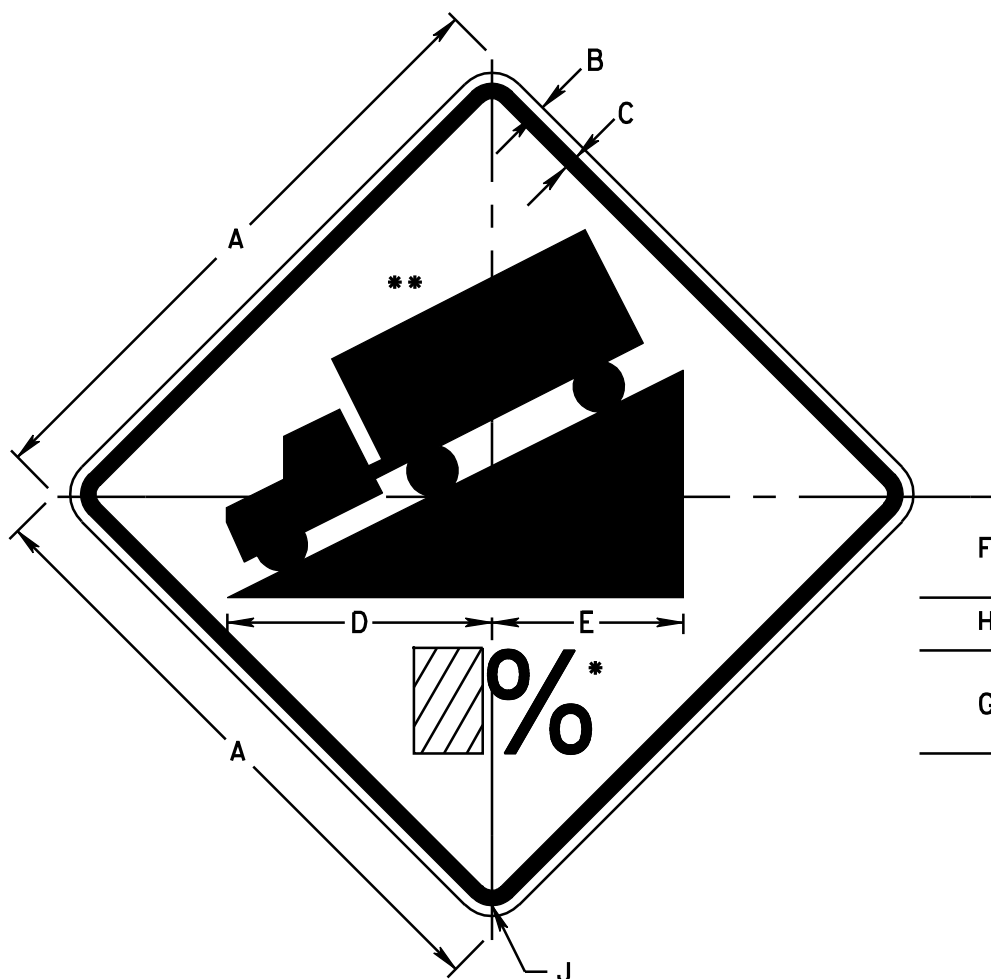

**COLORS**

LEGEND - BLACK (NON-REF)  
 BACKGROUND - YELLOW (REF)

**DIMENSIONS (INCHES)**

A	B	C	D	E	F	G	H	J
36	5/8	7/8	15 3/8	11 1/8	6	6D	3	1 5/8
48	3/4	1 1/4	20 1/2	14 1/2	8	8D	4	2 1/4

FRACTIONS SHALL NOT BE USED TO REPRESENT THE GRADE.

\* - OPTICALLY SPACE NUMERAL AND PERCENT ABOUT VERTICAL CENTERLINE

\*\* - SEE APPENDIX FOR SYMBOL DESIGN

WHEN USED IN CONSTRUCTION OR MAINTENANCE OPERATIONS  
 THE SIGN SHALL HAVE AN ORANGE REFLECTIVE BACKGROUND,  
 AND SHALL HAVE THE SUFFIX "M" ADDED TO THE FABRICATION NUMBER.

W7-1B CODE	W7-1BM CODE
30" 020601	36" _____
36" 020602	48" _____
48" 020603	_____



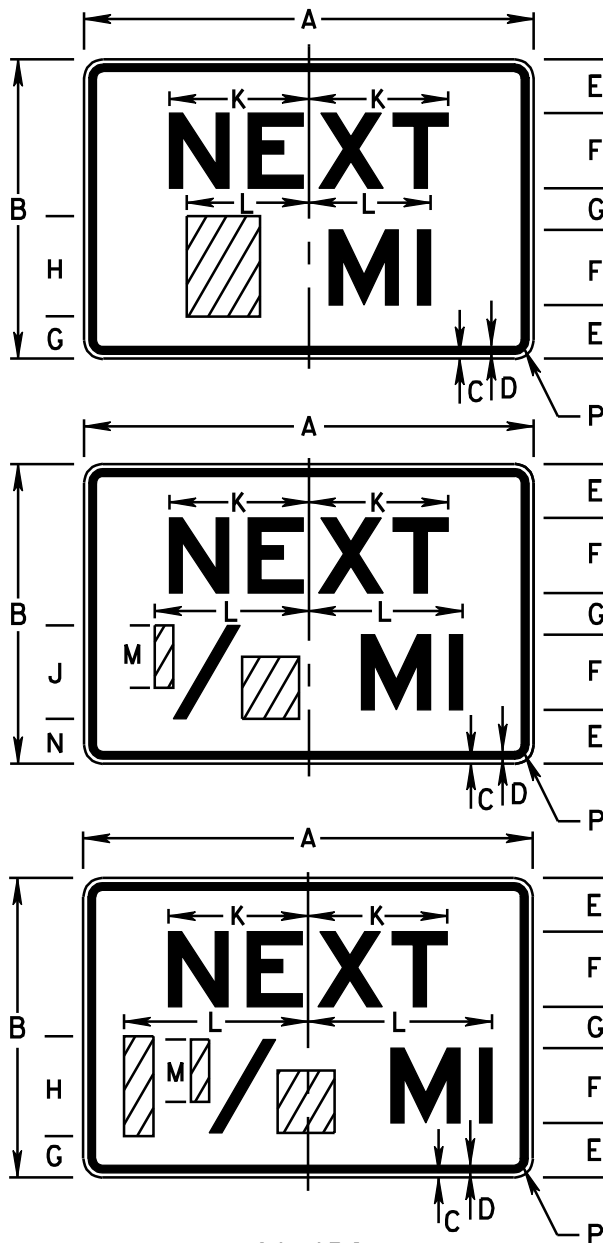

**COLORS**

LEGEND - BLACK (NON-REF)  
 BACKGROUND - YELLOW (REF)

**DIMENSIONS (INCHES)**

A	B	C	D	E	F	G	H	J	K	L	M	N	P
30	24	3/8	5/8	4 5/16	6E	3 5/16	8E	7 1/2	1 1 3/16	VAR	5E	3 9/16	1 1/8
48	30	1/2	3/4	5	8E	4	10E	9	1 4 7/8	VAR	6E	4 1/2	1 3/8

DISTANCES BEYOND 1 1/2 MILES SHALL BE SHOWN TO THE NEAREST MILE  
 WHEN USED IN CONSTRUCTION OR MAINTENANCE OPERATIONS  
 THE SIGN SHALL HAVE AN ORANGE REFLECTIVE BACKGROUND,  
 AND SHALL HAVE THE SUFFIX "M" ADDED TO THE FABRICATION NUMBER.

WV DEPARTMENT OF TRANSPORTATION  
 DIVISION OF HIGHWAYS  
 TRAFFIC ENGINEERING DIVISION

<b>W7-3A CODE</b>
30"x24" 1020714
48"x30" 1020712

**W7-3A**

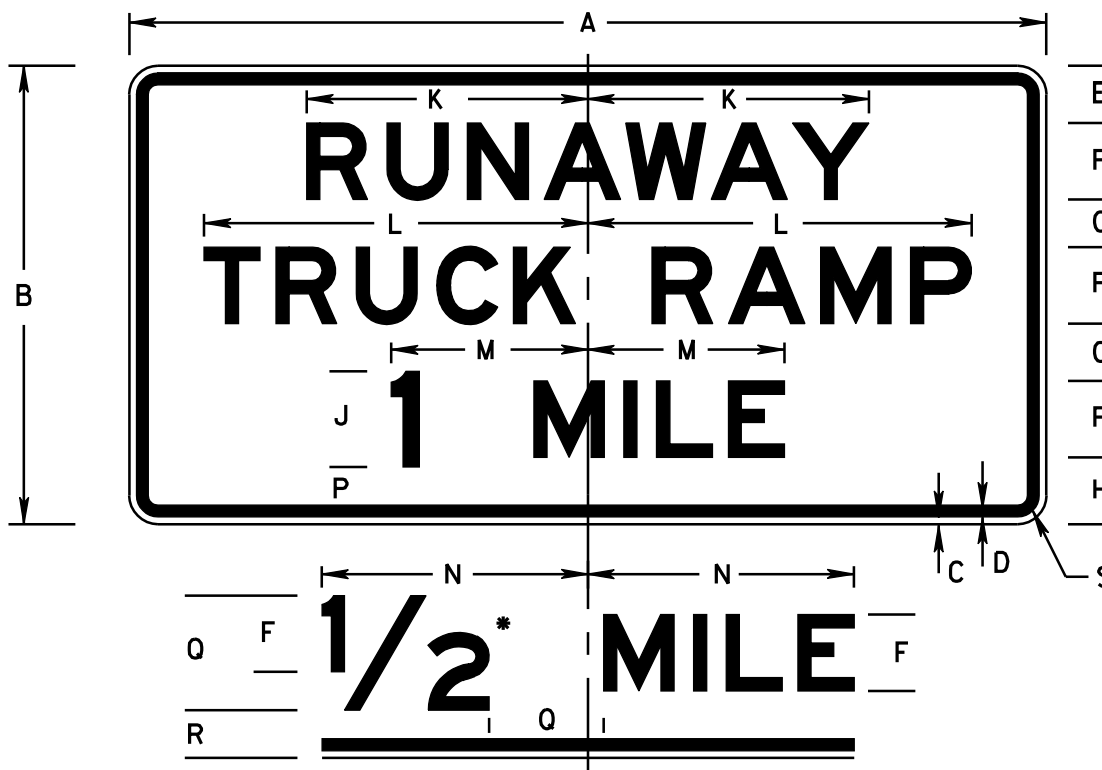

COLORS  
 LEGEND - BLACK (NON-REF)  
 BACKGROUND - YELLOW (REF)

DIMENSIONS (INCHES)

A	B	C	D	E	F	G	H	J	K	L	M	N
66	42	5/8	7/8	6	6D	6	6	8D	18 13/16	26 3/16	13 7/16	18 13/16
96	48	3/4	1 1/4	6	8E	5	7	10E	29 7/16	40 3/16	20 9/16	27 7/8
144	72	1	1 1/2	8 1/2	12E	8	10	15E	44 3/16	60 1/4	30 7/8	41 13/16

P	Q	R	S
5	9	4 1/2	1 5/8
6	12	5	2 1/4
8 1/2	18	7	2 3/4

\* - SEE APPENDIX FOR FRACTION DETAILS  
 96X48 AND 144X72 - EXTRUDED PANEL

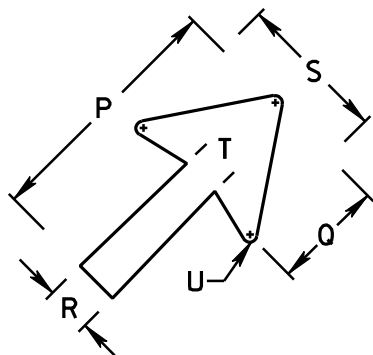
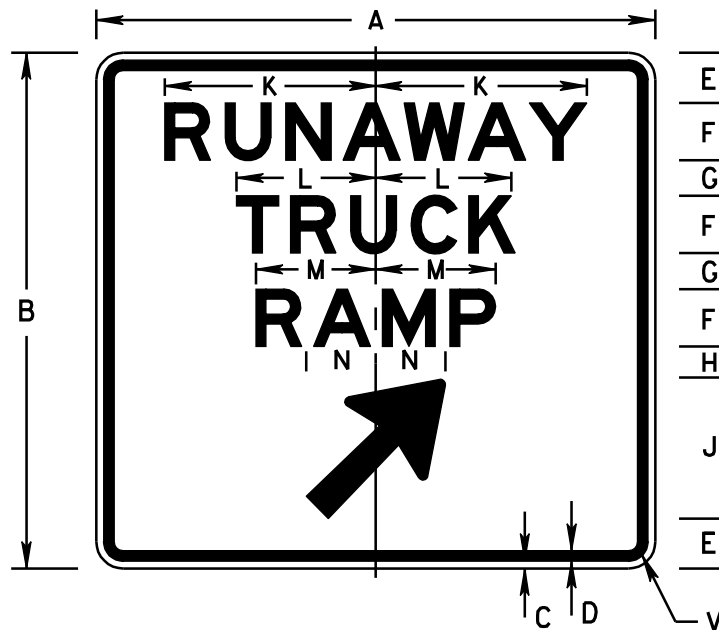

COLORS  
 LEGEND - BLACK (NON-REF)  
 BACKGROUND - YELLOW (REF)

DIMENSIONS (INCHES)

A	B	C	D	E	F	G	H	J	K	L	M	N	P
48	54	3/4	1 1/4	5	6D	4	4 5/8	13 7/8	18 13/16	12 1/2	10 11/16	6 11/16	16 3/4
78	72	1	1 1/2	7	8E	5	4 5/8	19 3/8	29 7/16	19 7/16	16 3/4	9 3/4	24 5/16

Q	R	S	T	U	V
7 3/8	3 1/16	10	2 5/8	1/2	2 1/4
10 11/16	4 7/16	14 7/16	3 13/16	11/16	2 3/4

78X72 - EXTRUDED PANEL

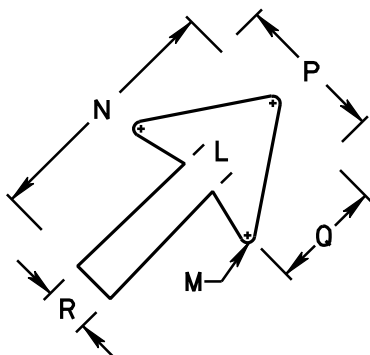
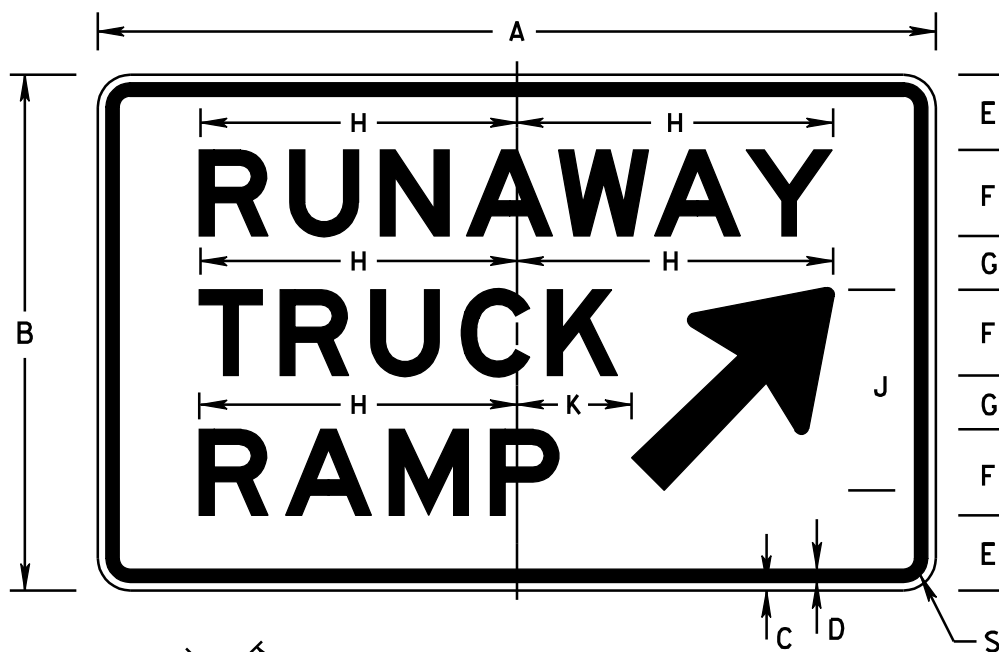

COLORS

LEGEND - BLACK (NON-REF)  
 BACKGROUND - YELLOW (REF)

DIMENSIONS (INCHES)

A	B	C	D	E	F	G	H	J	K	L	M	N	P
60	36	5/8	7/8	5	6E	4	22 1/16	13 3/8	8 11/16	2 5/8	1/2	16 3/4	10
78	48	3/4	1 1/4	7	8E	5	29 7/16	18 7/8	10 11/16	3 11/16	1/16	23 9/16	14 1/16

Q	R	S
7 3/8	3 1/16	1 5/8
10 3/8	4 1/4	2 1/4

78X48 - EXTRUDED PANEL

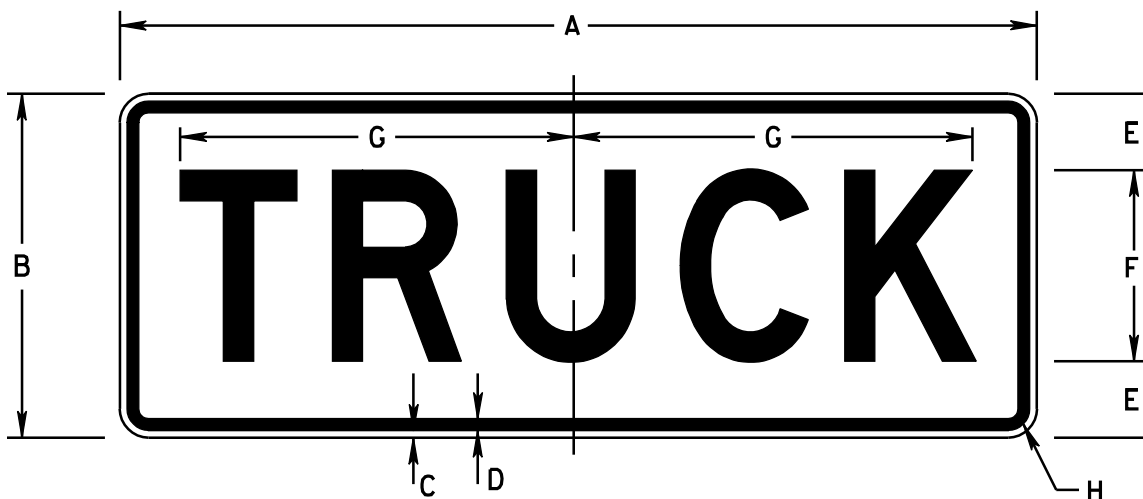

COLORS

LEGEND - BLACK (NON-REF)

BACKGROUND - YELLOW (REF)

DIMENSIONS (INCHES)

A	B	C	D	E	F	G	H
48	18	$\frac{3}{8}$	$\frac{5}{8}$	4	10D	$20\frac{13}{16}$	$1\frac{1}{8}$

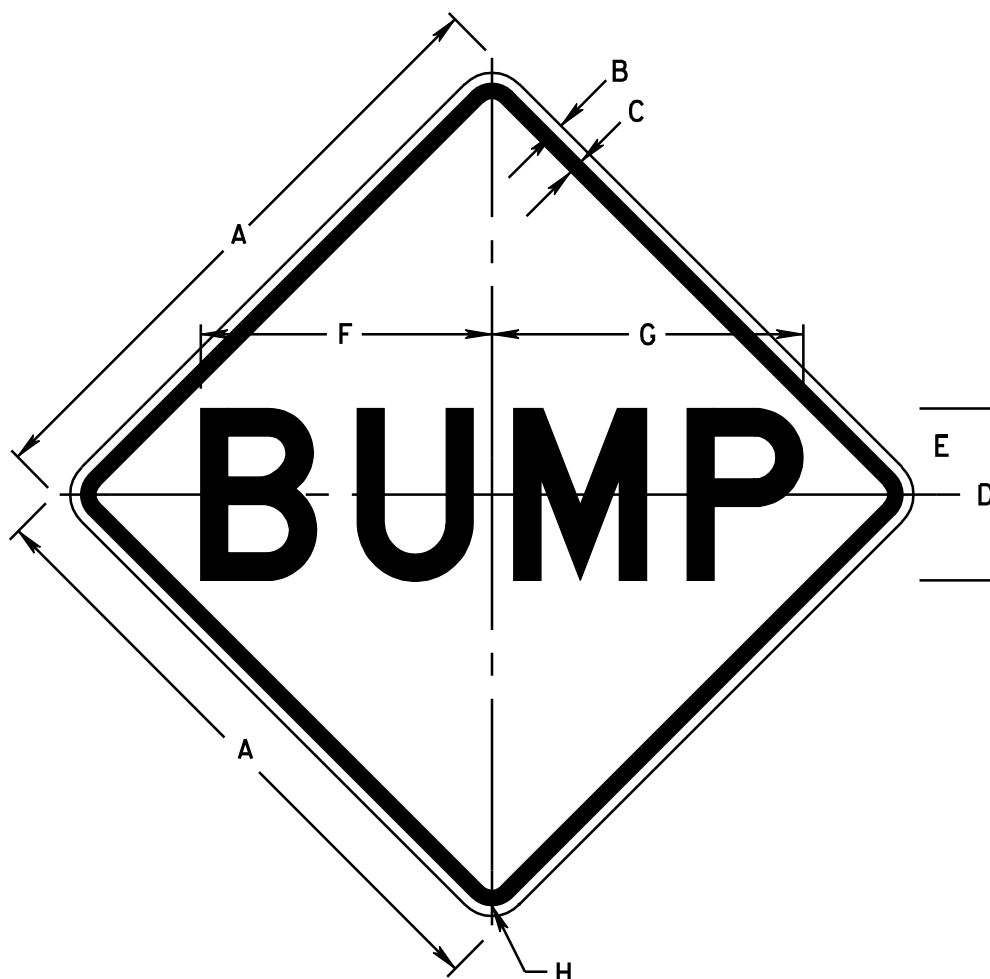

**COLORS**

LEGEND - BLACK (NON-REF)  
 BACKGROUND - YELLOW (REF)

**DIMENSIONS (INCHES)**

A	B	C	D	E	F	G	H
30	1/2	3/4	8D	4	13 5/8	14 3/8	1 3/8
36	5/8	7/8	10D	5	16 15/16	17 15/16	1 5/8
48	3/4	1 1/4	12D	6	20 3/8	21 5/8	2 1/4

48" AND 30" - WHEN USED IN CONSTRUCTION OR MAINTENANCE OPERATIONS  
 THE SIGN SHALL HAVE AN ORANGE REFLECTIVE BACKGROUND,  
 AND SHALL HAVE THE SUFFIX "M" ADDED TO THE FABRICATION NUMBER.

WB-1 CODE	WB-1M CODE
30"	020801 30"M
36"	48"M
48"	020802

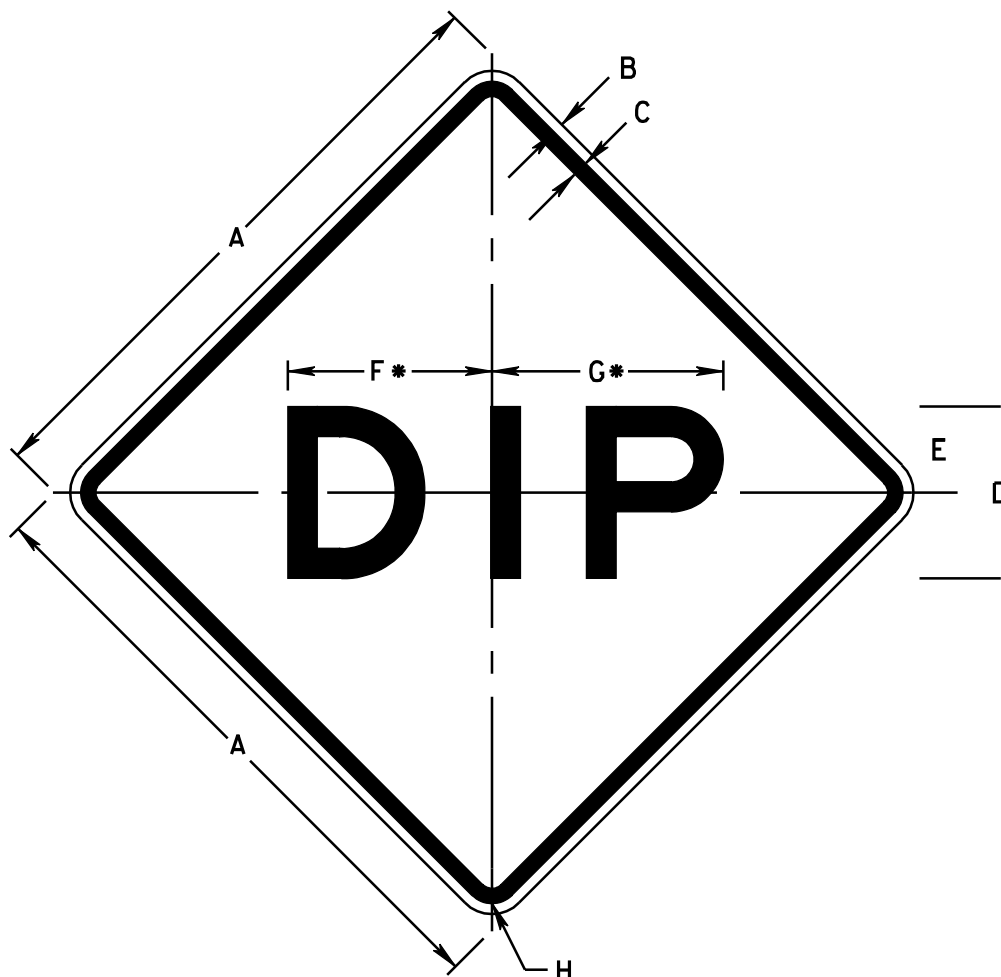

COLORS

LEGEND - BLACK (NON-REF)  
 BACKGROUND - YELLOW (REF)

DIMENSIONS (INCHES)

A	B	C	D	E	F	G	H
30	1/2	3/4	8E	4	9 1/2	10 7/8	1 3/8
36	5/8	7/8	10E	5	11 7/8	13 1/2	1 5/8
48	3/4	1 1/4	12E	6	14 1/4	16 1/4	2 1/4

\* - INCREASE SPACING 50%

48" AND 30" - WHEN USED IN CONSTRUCTION OR MAINTENANCE OPERATIONS  
 THE SIGN SHALL HAVE AN ORANGE REFLECTIVE BACKGROUND,  
 AND SHALL HAVE THE SUFFIX "M" ADDED TO THE FABRICATION NUMBER.

W8-2 CODE	W8-2M CODE
30" 020810	30"M
36" 020811	36"M
48" 020811	48"M

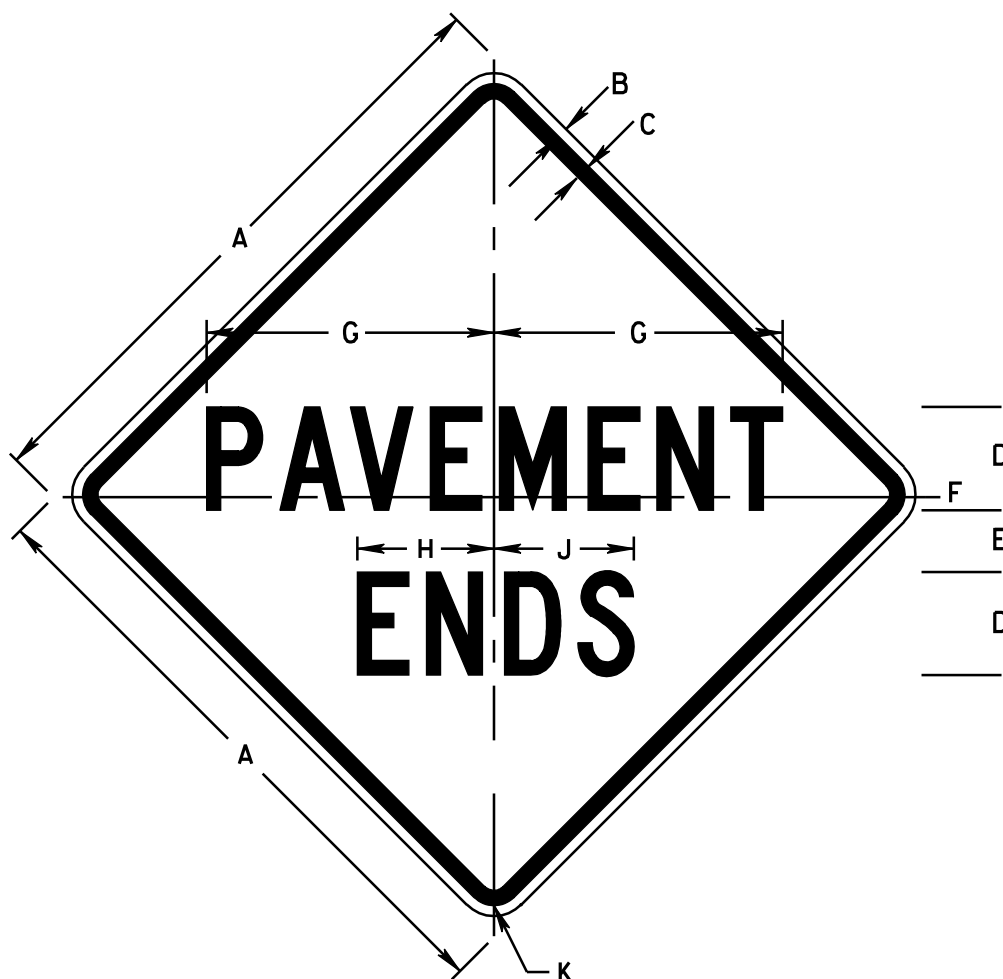

**COLORS**

LEGEND - BLACK (NON-REF)  
 BACKGROUND - YELLOW (REF)

**DIMENSIONS (INCHES)**

A	B	C	D	E	F	G	H	J	K
30	1/2	3/4	5C	3	3/4	13 5/16	6 5/8	6 7/8	1 3/8
36	5/8	7/8	6C	3 1/2	1	16 3/4	7 7/8	8 1/4	1 5/8
48	3/4	1 1/4	8C	4 13/16	1 3/16	22 3/8	10 5/8	10 7/8	2 1/4

48" AND 30" - WHEN USED IN CONSTRUCTION OR MAINTENANCE OPERATIONS  
 THE SIGN SHALL HAVE AN ORANGE REFLECTIVE BACKGROUND,  
 AND SHALL HAVE THE SUFFIX "M" ADDED TO THE FABRICATION NUMBER.

WB-3 CODE	WB-3M CODE
30" 020815	30"M
36" 020816	48"M
48" 020816	



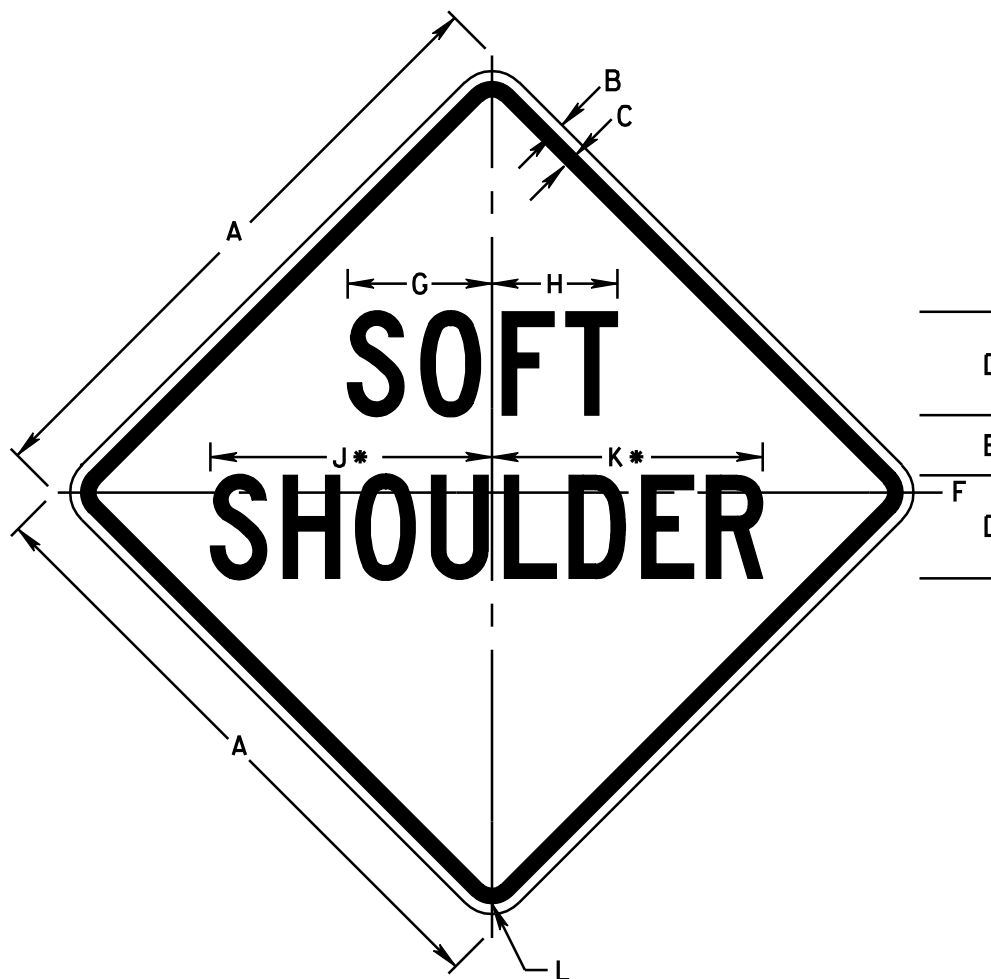

**COLORS**

LEGEND - BLACK (NON-REF)  
 BACKGROUND - YELLOW (REF)

**DIMENSIONS (INCHES)**

A	B	C	D	E	F	G	H	J	K	L
30	1/2	3/4	5C	3	3/4	7	6 1/8	13 1/16	13 1/16	1 3/8
36	5/8	7/8	6C	3 1/2	1	8 3/8	7 3/8	16 1/2	15 3/4	1 5/8
48	3/4	1 1/4	8C	5	1 1/4	11 1/8	9 1/16	21 7/8	20 7/8	2 1/4

\* - REDUCE SPACING 25%

48" AND 36" - WHEN USED IN CONSTRUCTION OR MAINTENANCE OPERATIONS  
 THE SIGN SHALL HAVE AN ORANGE REFLECTIVE BACKGROUND,  
 AND SHALL HAVE THE SUFFIX "M" ADDED TO THE FABRICATION NUMBER.

WB-4 CODE	WB-4M CODE
30" 020820	36"M
36" 020821	48"M
48" 020822	

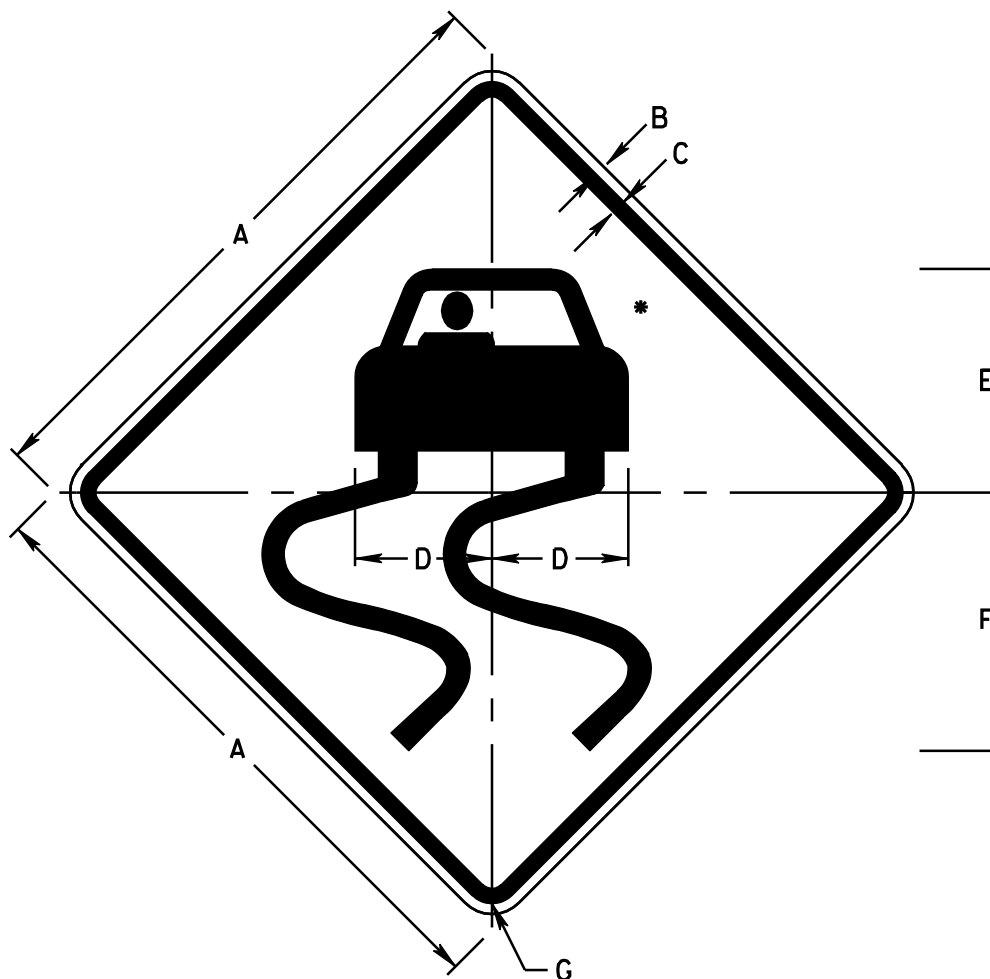

COLORS

LEGEND - BLACK (NON-REF)  
 BACKGROUND - YELLOW (REF)

DIMENSIONS (INCHES)

A	B	C	D	E	F	G
30	1/2	3/4	6 5/8	10 13/16	12 1/2	1 3/8
36	5/8	7/8	7 15/16	13	15	1 5/8
48	3/4	1 1/4	10 9/16	17 5/16	20	2 1/4

\* - SEE APPENDIX FOR SYMBOL DESIGN

48" AND 36" - WHEN USED IN CONSTRUCTION OR MAINTENANCE OPERATIONS  
 THE SIGN SHALL HAVE AN ORANGE REFLECTIVE BACKGROUND,  
 AND SHALL HAVE THE SUFFIX "M" ADDED TO THE FABRICATION NUMBER.

W8-5 CODE	W8-5M CODE
30" 020826	36"M
36" 020827	48"M
48" 020828	

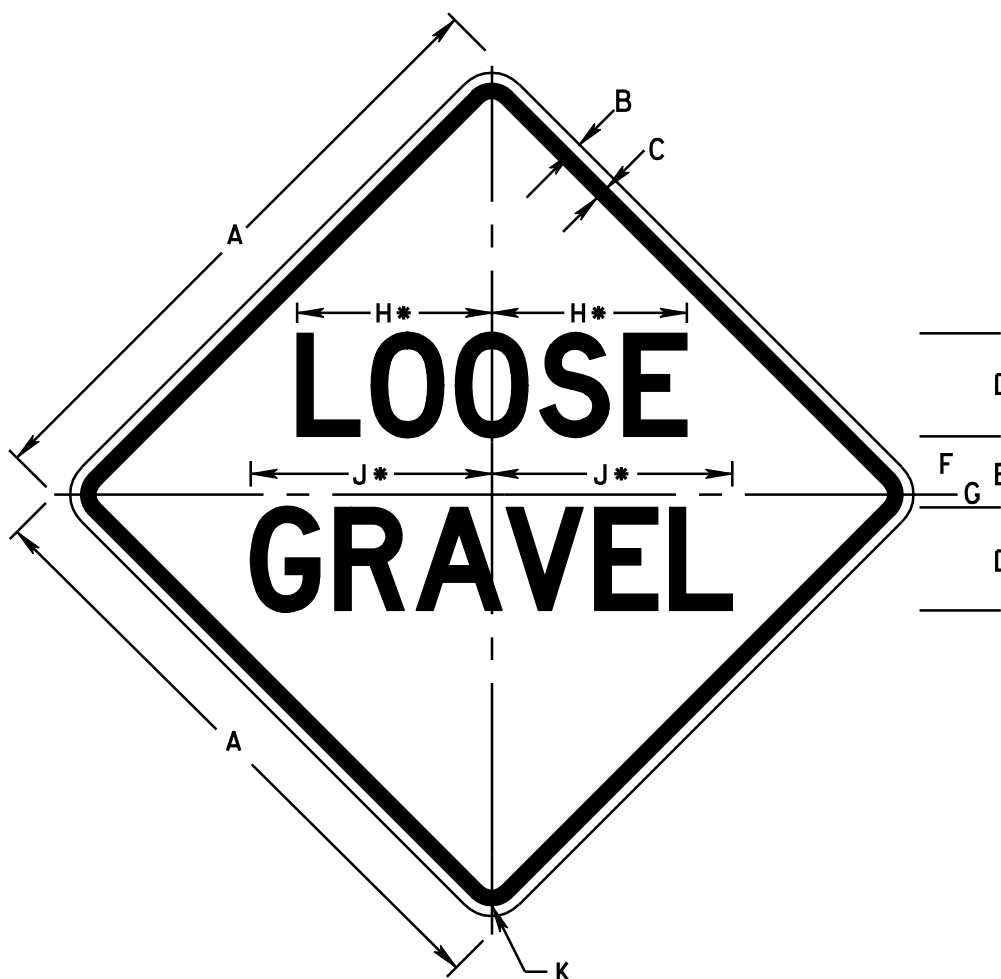

**COLORS**

LEGEND - BLACK (NON-REF)  
 BACKGROUND - YELLOW (REF)

**DIMENSIONS (INCHES)**

A	B	C	D	E	F	G	H	J	K
30	1/2	3/4	5D	3 7/16	2 13/16	5/8	9 7/16	11 11/16	1 3/8
36M	5/8	7/8	6D	4 1/8	3 3/8	3/4	11 5/16	14	1 5/8
48	3/4	1 1/4	8D	5 1/2	4 1/2	1	15 1/8	18 11/16	2 1/4

\* - REDUCE SPACING 40%

30" - YELLOW REFLECTIVE BACKGROUND ONLY.

36"M - ORANGE REFLECTIVE BACKGROUND ONLY.

48" - WHEN USED IN CONSTRUCTION OR MAINTENANCE OPERATIONS  
 THE SIGN SHALL HAVE AN ORANGE REFLECTIVE BACKGROUND,  
 AND SHALL HAVE THE SUFFIX "M" ADDED TO THE FABRICATION NUMBER.

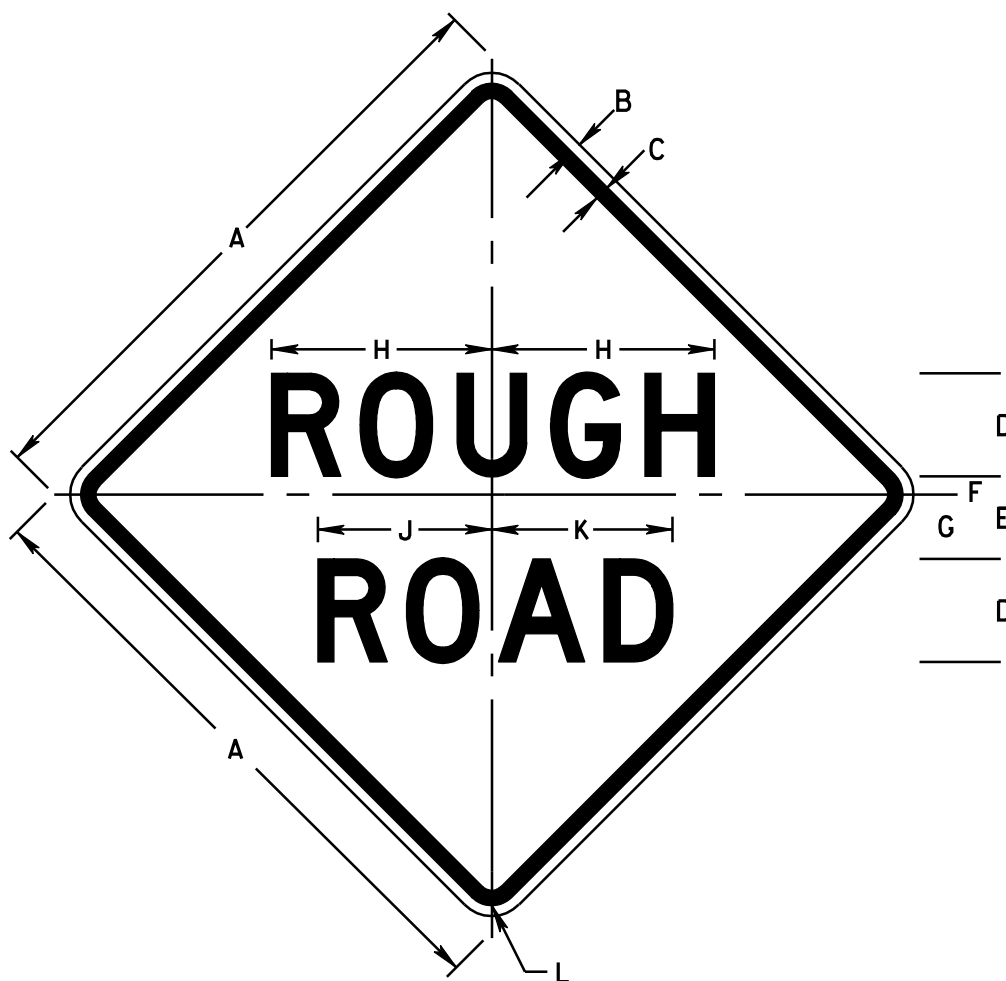

**COLORS**

LEGEND - BLACK (NON-REF)  
 BACKGROUND - YELLOW (REF)

**DIMENSIONS (INCHES)**

A	B	C	D	E	F	G	H	J	K	L
30	1/2	3/4	5D	4	7/8	3 1/8	10 11/16	8 7/16	8 3/4	1 3/8
36	5/8	7/8	6D	5	1	4	12 7/8	10 1/8	10 1/2	1 5/8
48	3/4	1 1/4	8D	6	1 1/2	4 1/2	17 1/8	13 1/2	14	2 1/4

48" AND 30" - WHEN USED IN CONSTRUCTION OR MAINTENANCE OPERATIONS  
 THE SIGN SHALL HAVE AN ORANGE REFLECTIVE BACKGROUND,  
 AND SHALL HAVE THE SUFFIX "M" ADDED TO THE FABRICATION NUMBER.

W8-8 CODE	W8-8M CODE
30"	020838 30"M
36"	48"M
48"	020839

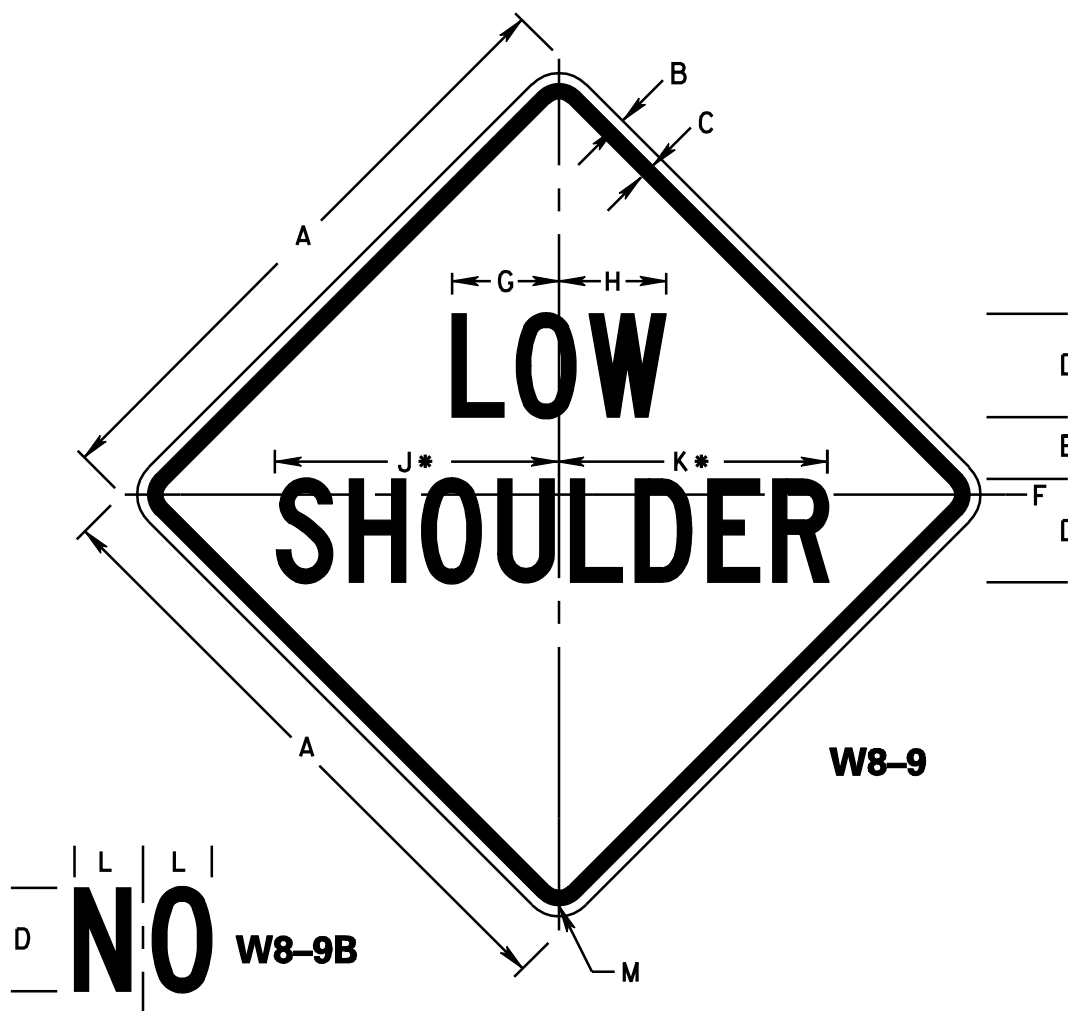

COLORS  
 LEGEND - BLACK (NON-REF)  
 BACKGROUND - YELLOW (REF)

DIMENSIONS (INCHES)

A	B	C	D	E	F	G	H	J	K	L	M
30	1/2	3/4	5C	3	3/4	5 3/16	5 5/8	13 11/16	13 1/16	3 5/16	1 3/8
36	5/8	7/8	6C	3 1/2	1	6 3/16	6 3/4	16 1/2	15 3/4	4	1 5/8
48	3/4	1 1/4	8C	5	1 1/4	8 1/4	9	21 7/8	20 7/8	5 5/16	2 1/4

\* - REDUCE SPACING 25%

48" AND 36" - WHEN USED IN CONSTRUCTION OR MAINTENANCE OPERATIONS  
 THE SIGN SHALL HAVE AN ORANGE REFLECTIVE BACKGROUND,  
 AND SHALL HAVE THE SUFFIX "M" ADDED TO THE FABRICATION NUMBER.

WV DEPARTMENT OF TRANSPORTATION  
 DIVISION OF HIGHWAYS  
 TRAFFIC ENGINEERING DIVISION

W8-9 CODE	W8-9M CODE
30"	020845
36"	
48"	020846
W8-9B CODE	W8-9BM CODE
30"	
36"	
48"	

**W8-9**

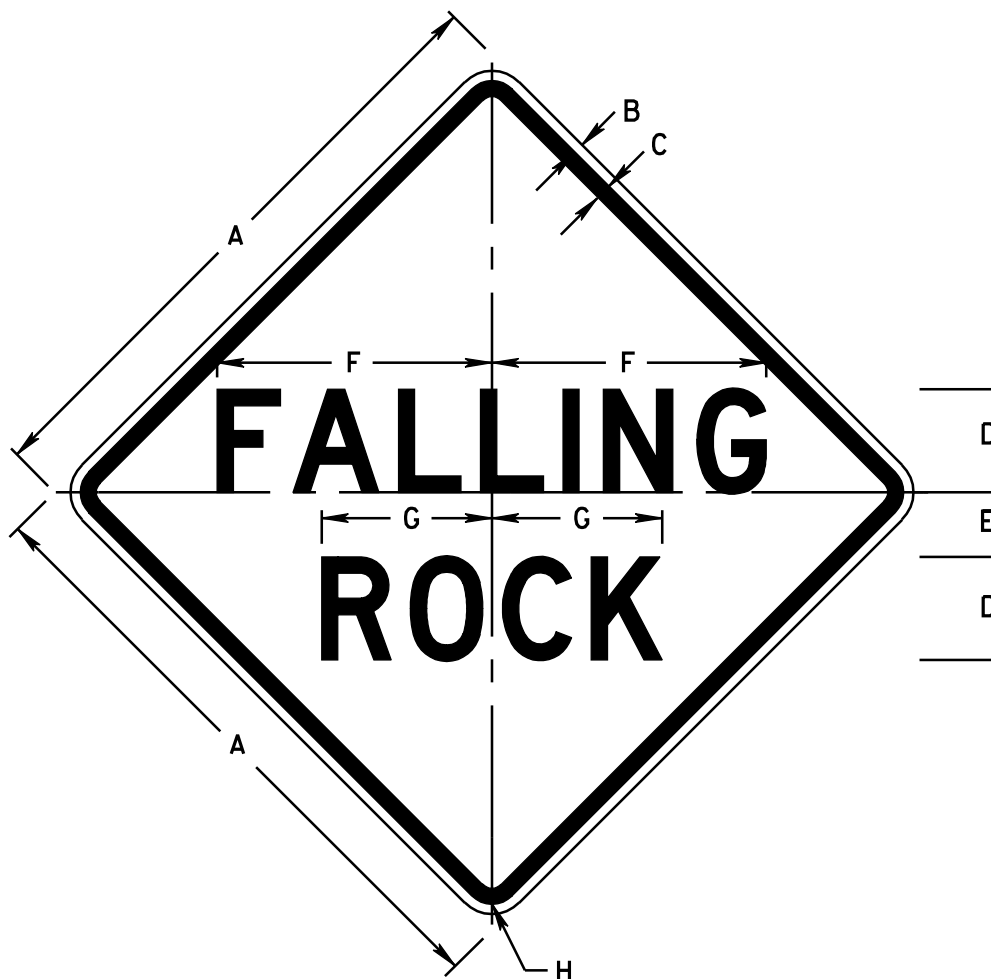

**COLORS**

LEGEND - BLACK (NON-REF)  
 BACKGROUND - YELLOW (REF)

**DIMENSIONS (INCHES)**

A	B	C	D	E	F	G	H
30	1/2	3/4	5D	3 1/2	13 5/16	8 3/16	1 1/8
36	5/8	7/8	6D	3 3/4	16	9 7/8	1 5/8
48	3/4	1 1/4	8D	5	21 5/16	13 1/8	2 1/4

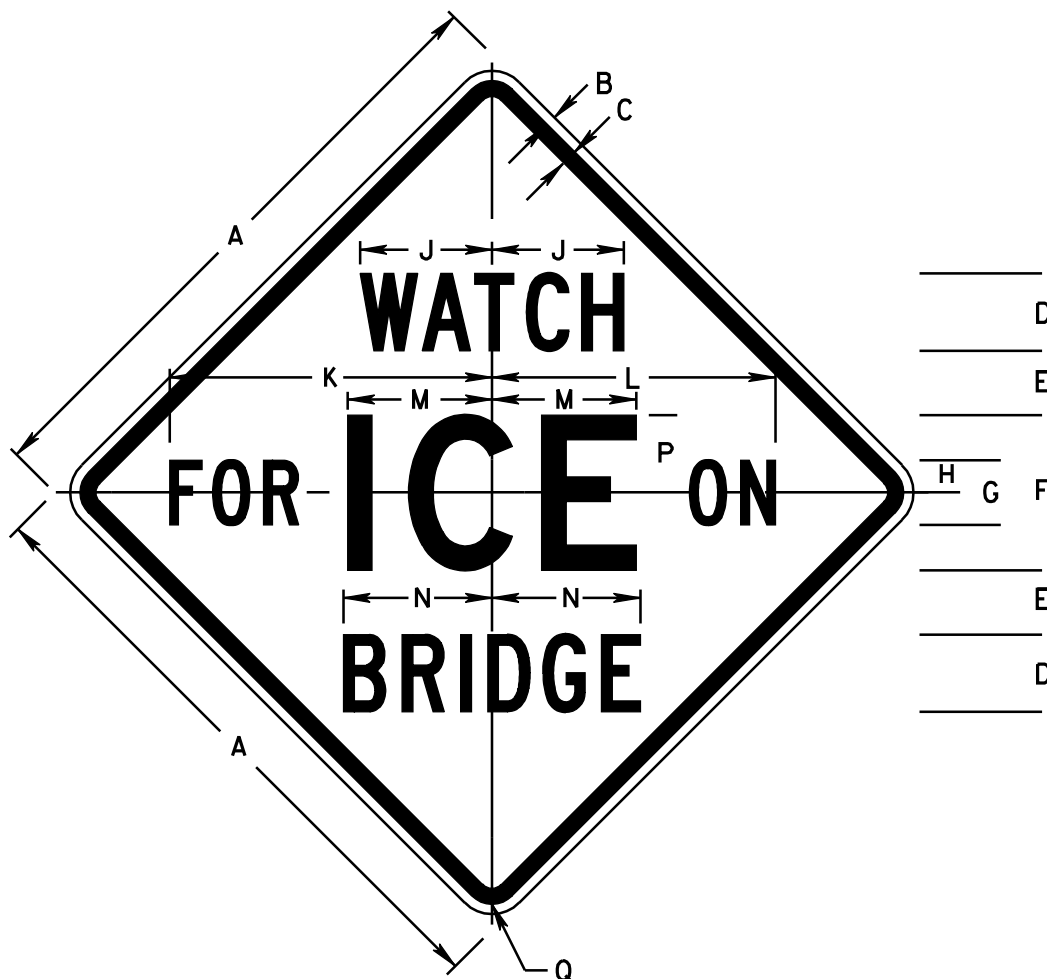

**COLORS**

LEGEND - BLACK (NON-REF)  
 BACKGROUND - YELLOW (REF)

**DIMENSIONS (INCHES)**

A	B	C	D	E	F	G	H	J	K	L	M	N	P	Q
36	$\frac{5}{8}$	$\frac{7}{8}$	4C	4	9D	3C	1 1/2	6 1/16	17 3/8	16 3/16	8 3/8	7 1/16	4 1/2	1 5/8
48	$\frac{3}{4}$	1 1/4	6C	5	12D	5C	2 1/2	10 1/4	25	22	11 3/16	11 1/2	6	2 1/4

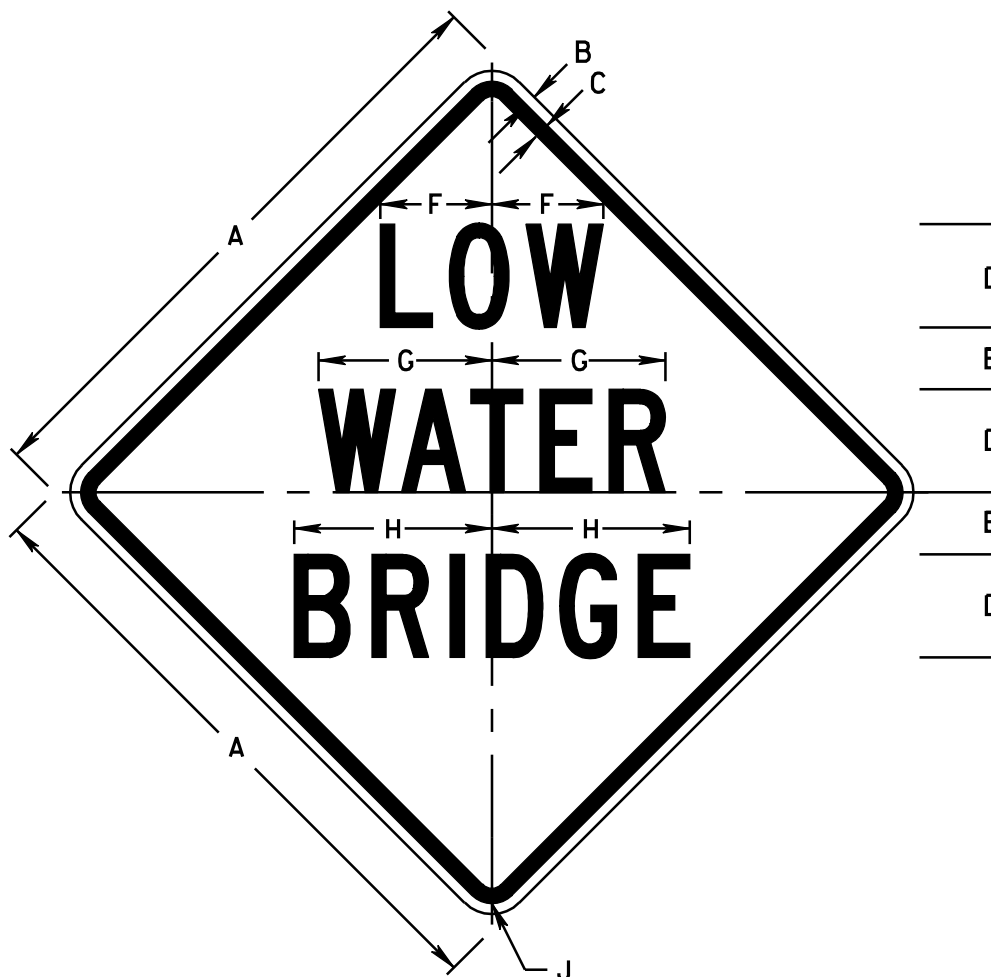

**COLORS**

LEGEND - BLACK (NON-REF)  
 BACKGROUND - YELLOW (REF)

**DIMENSIONS (INCHES)**

A	B	C	D	E	F	G	H	J
30	1/2	3/4	5C	3	5 3/8	8 7/16	9 9/16	1 3/8

TO BE USED IN CONJUNCTION WITH SIGN W8-15A





COLORS

LEGEND - BLACK (NON-REF)  
 BACKGROUND - YELLOW (REF)

DIMENSIONS (INCHES)

A	B	C	D	E	F	G	H	J	K	L
24	18	3/8	5/8	2 3/4	3C	1 3/4	6 7/16	9 13/16	7 1/4	1 1/8

TO BE USED IN CONJUNCTION WITH SIGN W8-15

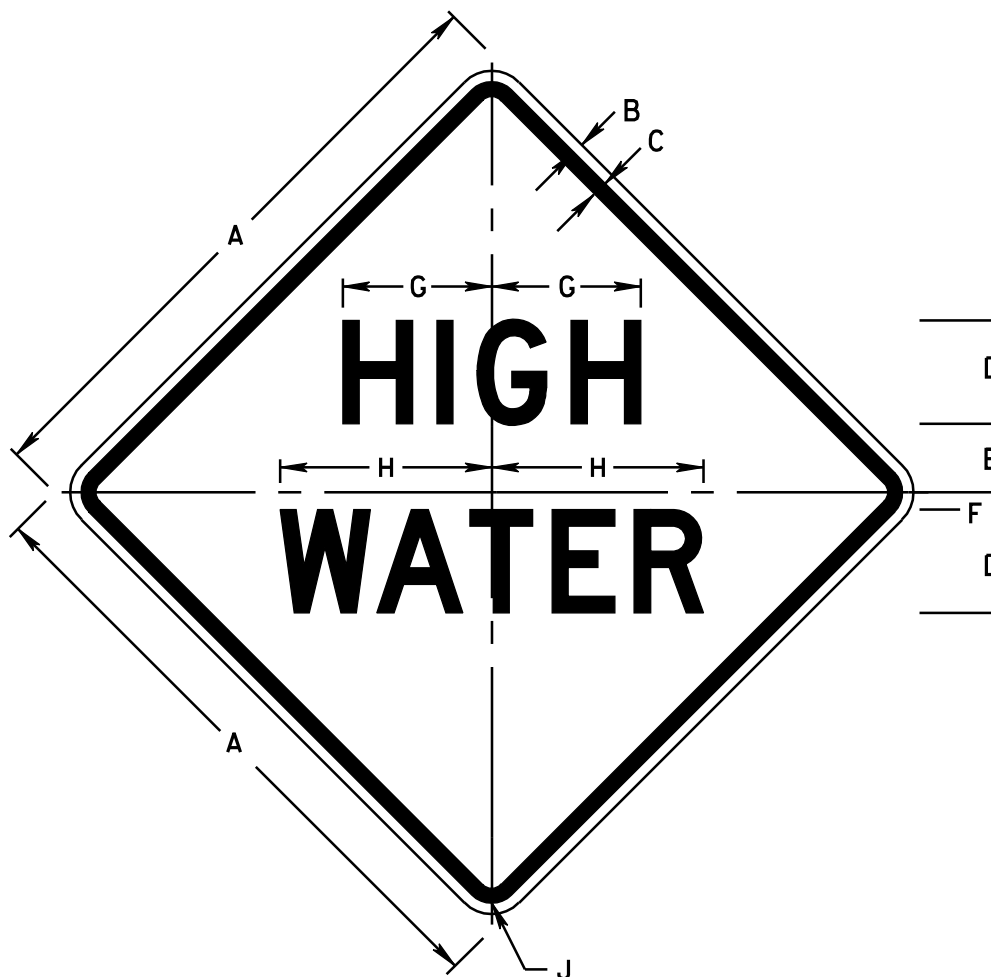

**COLORS**

LEGEND - BLACK (NON-REF)  
 BACKGROUND - YELLOW (REF)

**DIMENSIONS (INCHES)**

A	B	C	D	E	F	G	H	J
36	5/8	7/8	6D	4	1	8 5/8	12 5/16	1 5/8

WHEN USED IN CONSTRUCTION OR MAINTENANCE OPERATIONS  
 THE SIGN SHALL HAVE AN ORANGE REFLECTIVE BACKGROUND,  
 AND SHALL HAVE THE SUFFIX "M" ADDED TO THE FABRICATION NUMBER.

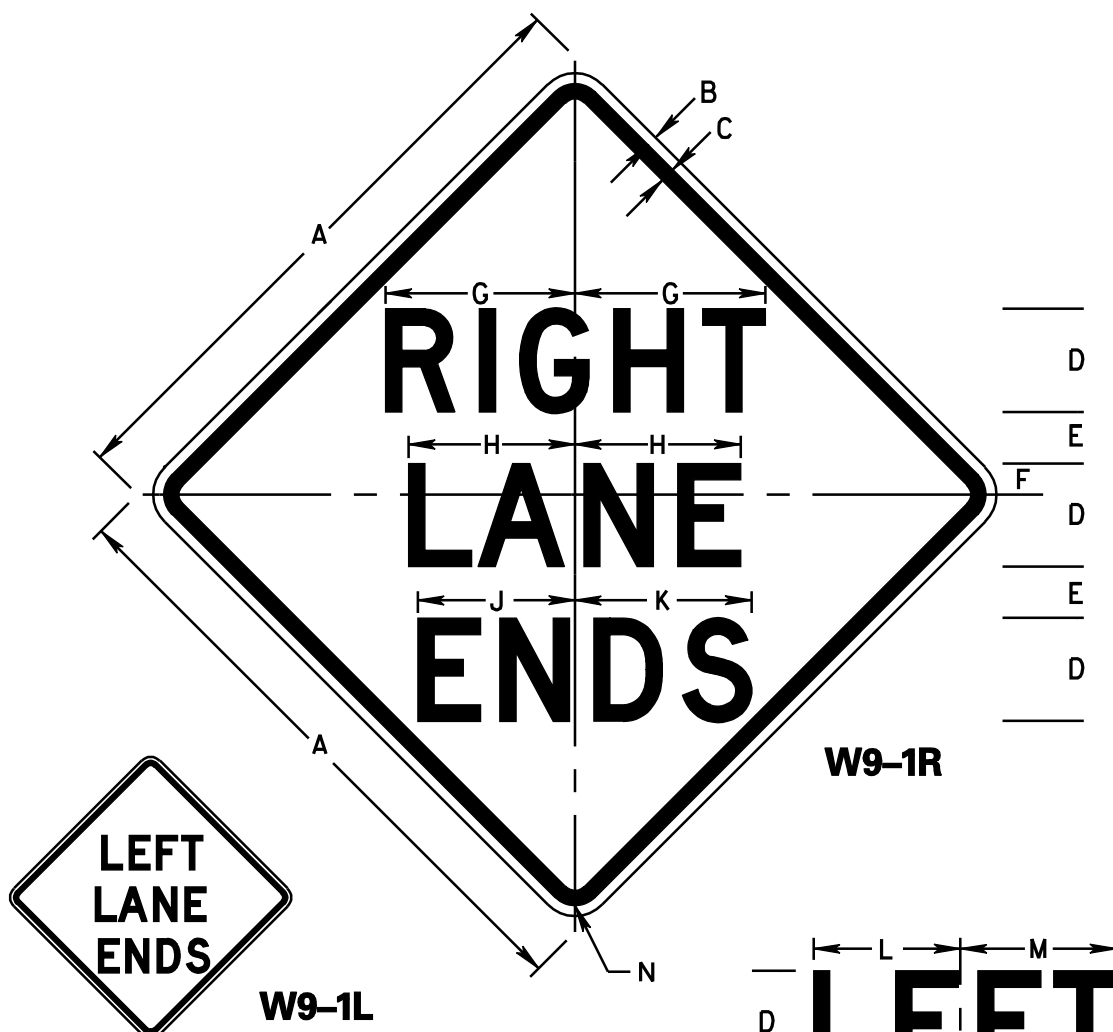

COLORS  
 LEGEND - BLACK (NON-REF)  
 BACKGROUND - YELLOW (REF)

DIMENSIONS (INCHES)

A	B	C	D	E	F	G	H	J	K	L	M	N
36	5/8	7/8	6D	3	2	11	9 11/16	9	10 3/8	8 1/2	9 1/8	1 5/8
48	3/4	1 1/4	8D	4	3	14 3/4	12 7/8	12 1/4	13 5/8	11 1/4	12 1/4	2 1/4

WHEN USED IN CONSTRUCTION OR MAINTENANCE OPERATIONS  
 THE SIGN SHALL HAVE AN ORANGE REFLECTIVE BACKGROUND,  
 AND SHALL HAVE THE SUFFIX "M" ADDED TO THE FABRICATION NUMBER.

W9-1R CODE	W9-1L CODE
36" 020902	36" 020910
48" 020903	48" 020911
36" M	36" M
48" M	48" M

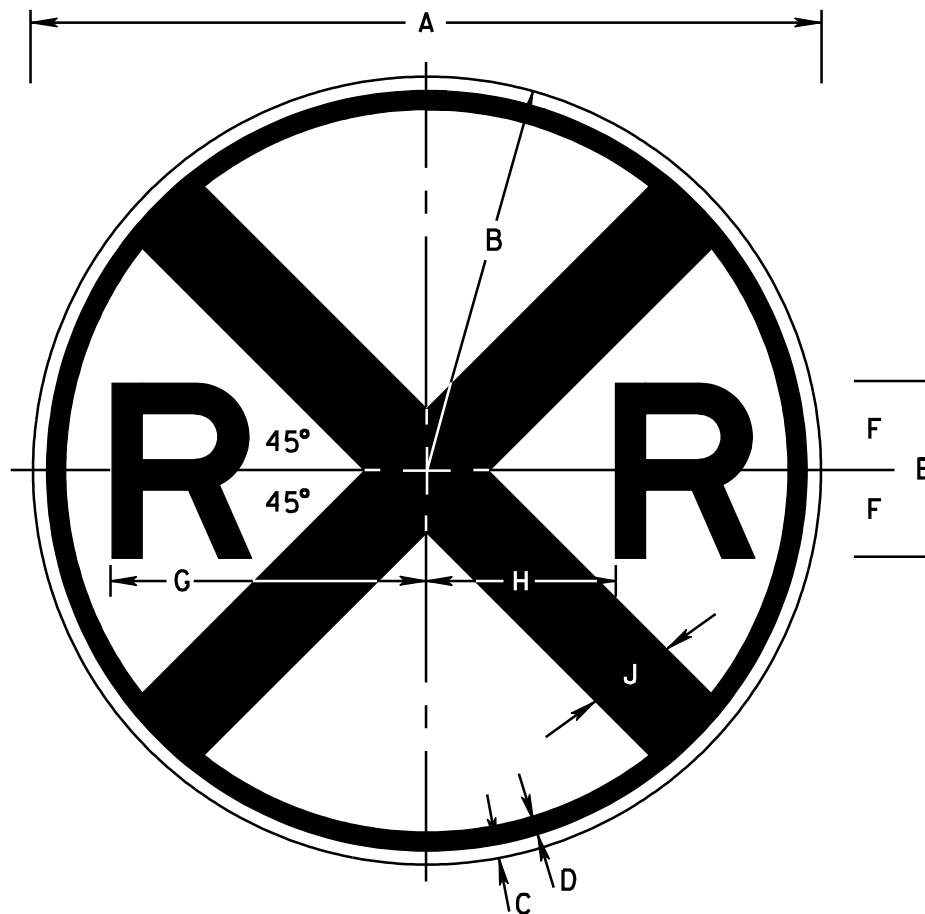

COLORS

LEGEND - BLACK (NON-REF)  
 BACKGROUND - YELLOW (REF)

DIMENSIONS (INCHES)

A	B	C	D	E	F	G	H	J
36	18	5/8	7/8	8E	4	14 3/8	8 5/8	4

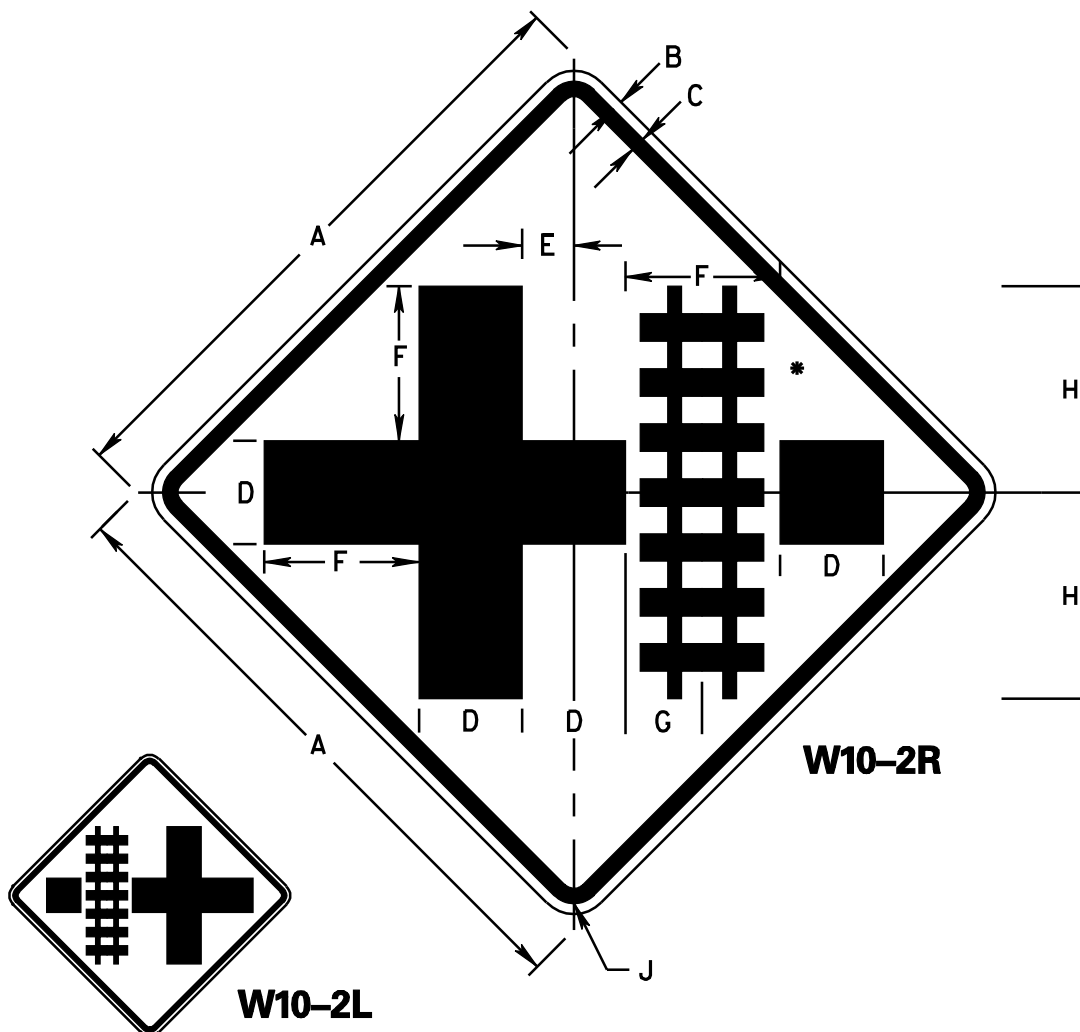

COLORS  
 LEGEND - BLACK (NON-REF)  
 BACKGROUND - YELLOW (REF)

DIMENSIONS (INCHES)

A	B	C	D	E	F	G	H	J
30	1/2	3/4	5	2 1/2	7 1/2	3 3/4	10	1 3/8
36	5/8	7/8	6	3	9	4 1/2	12	1 5/8

\* - SEE APPENDIX FOR SYMBOL DESIGN

W10-2R CODE	W10-2L CODE
30" 021004	30"
36"	36"

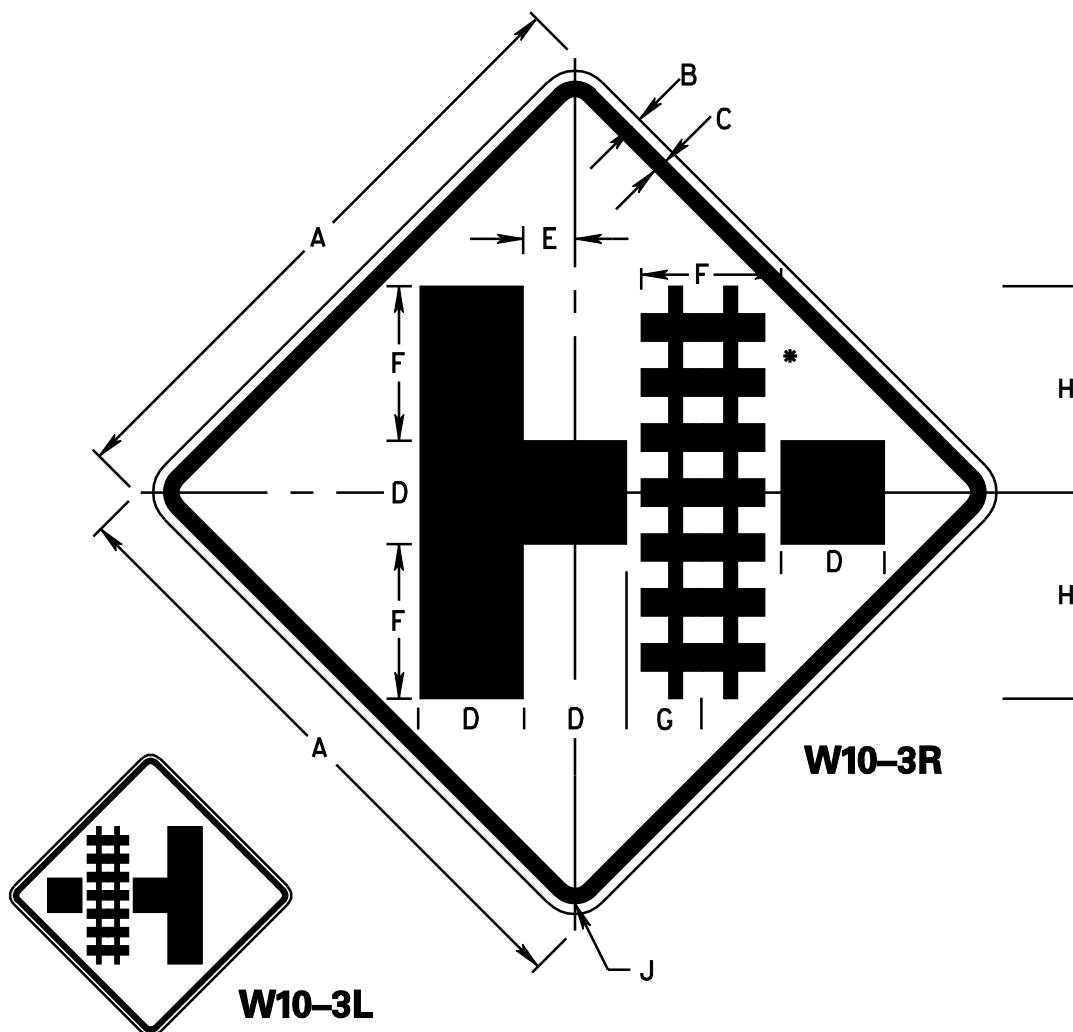

COLORS  
 LEGEND - BLACK (NON-REF)  
 BACKGROUND - YELLOW (REF)

DIMENSIONS (INCHES)

A	B	C	D	E	F	G	H	J
30	1/2	3/4	5	2 1/2	7 1/2	3 3/4	10	1 3/8
36	5/8	7/8	6	3	9	4 1/2	12	1 5/8

\* - SEE APPENDIX FOR SYMBOL DESIGN

W10-3R CODE		W10-3L CODE	
30"	021007	30"	
36"		36"	

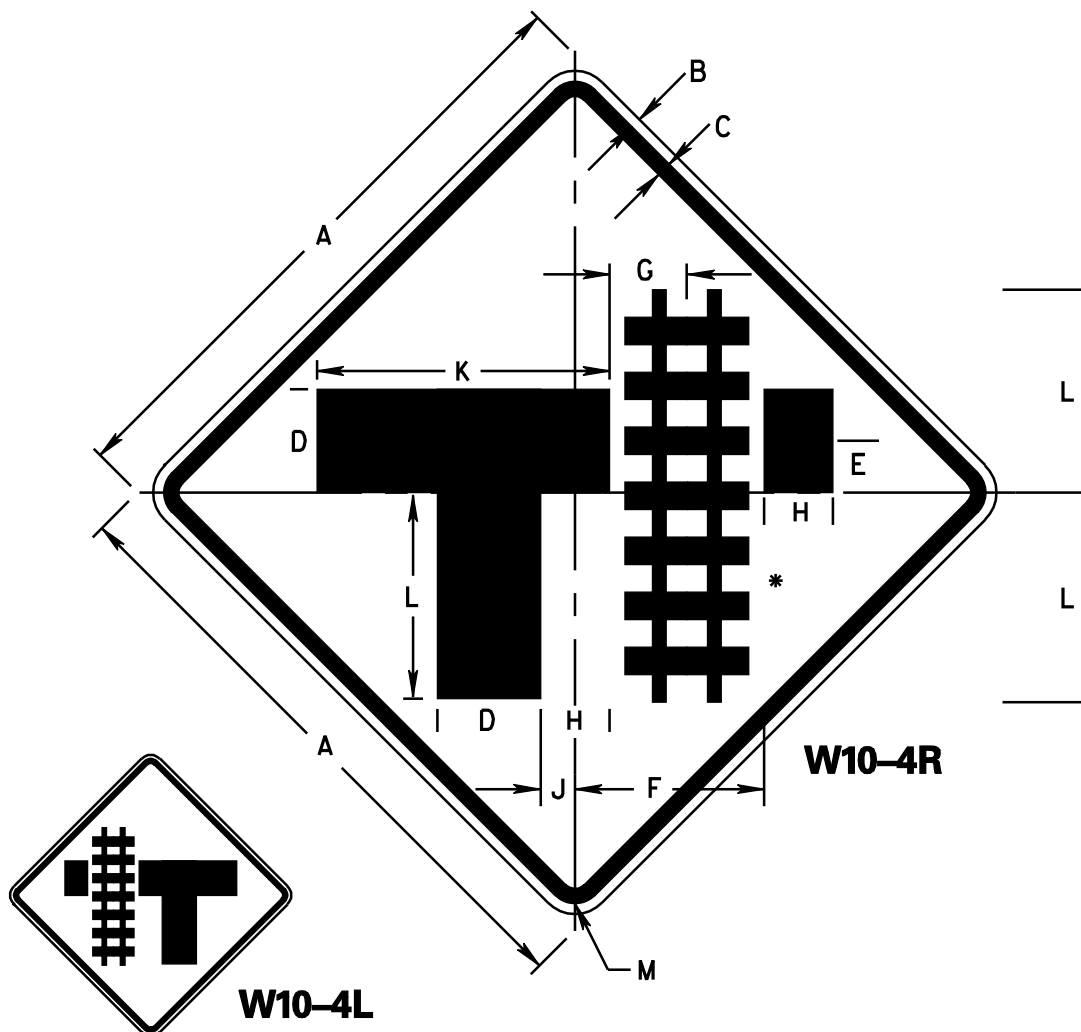

COLORS  
 LEGEND - BLACK (NON-REF)  
 BACKGROUND - YELLOW (REF)

DIMENSIONS (INCHES)

A	B	C	D	E	F	G	H	J	K	L	M
30	1/2	3/4	5	2 1/2	7 1/2	3 3/4	3 3/8	1 11/16	14 1/4	10	1 3/8
36	5/8	7/8	6	3	9	4 1/2	4	2	17	12	1 5/8

\* - SEE APPENDIX FOR SYMBOL DESIGN

W10-4R CODE	W10-4L CODE
30" 021010	30"
36"	36"

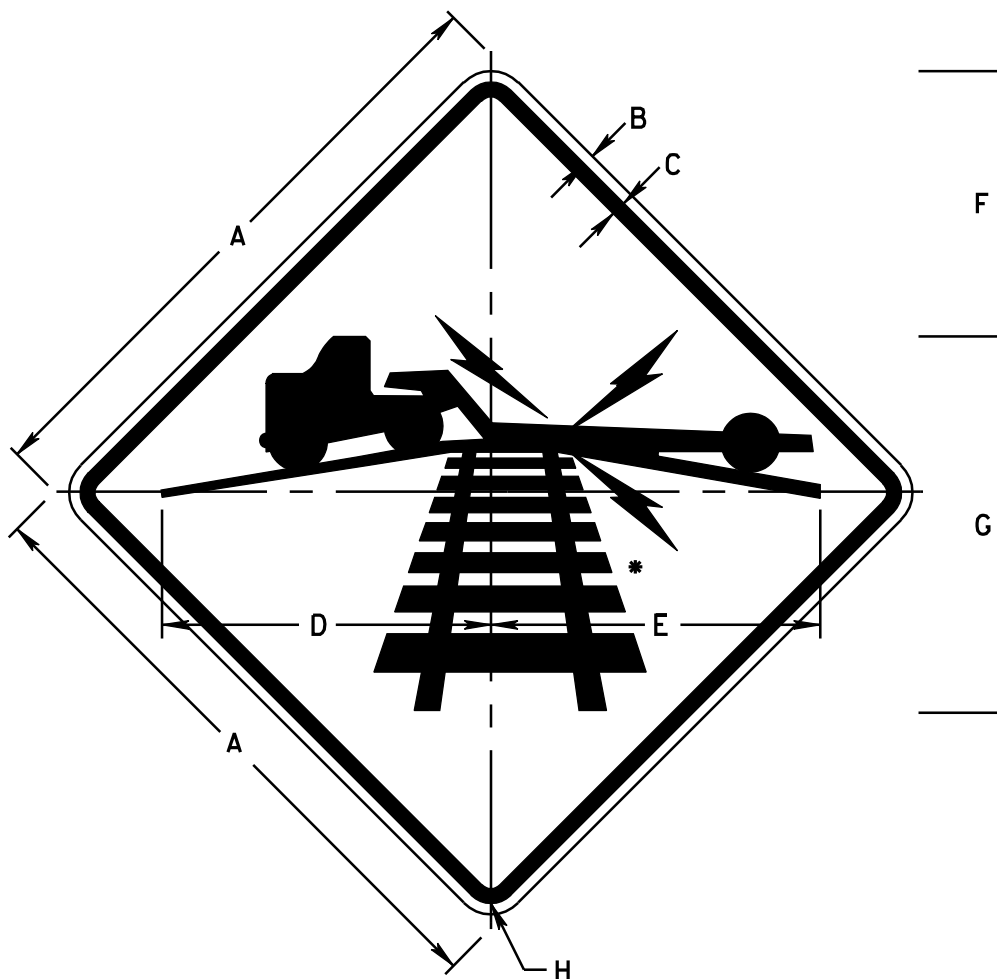

COLORS  
 LEGEND - BLACK (NON-REF)  
 BACKGROUND - YELLOW (REF)

DIMENSIONS (INCHES)

A	B	C	D	E	F	G	H
30	1/2	3/4	15 11/16	15 1/4	13 3/8	17 1/2	1 3/8
36	5/8	7/8	19 5/16	18 7/8	15 7/16	21 9/16	1 5/8

\* - SEE APPENDIX FOR SYMBOL DESIGN



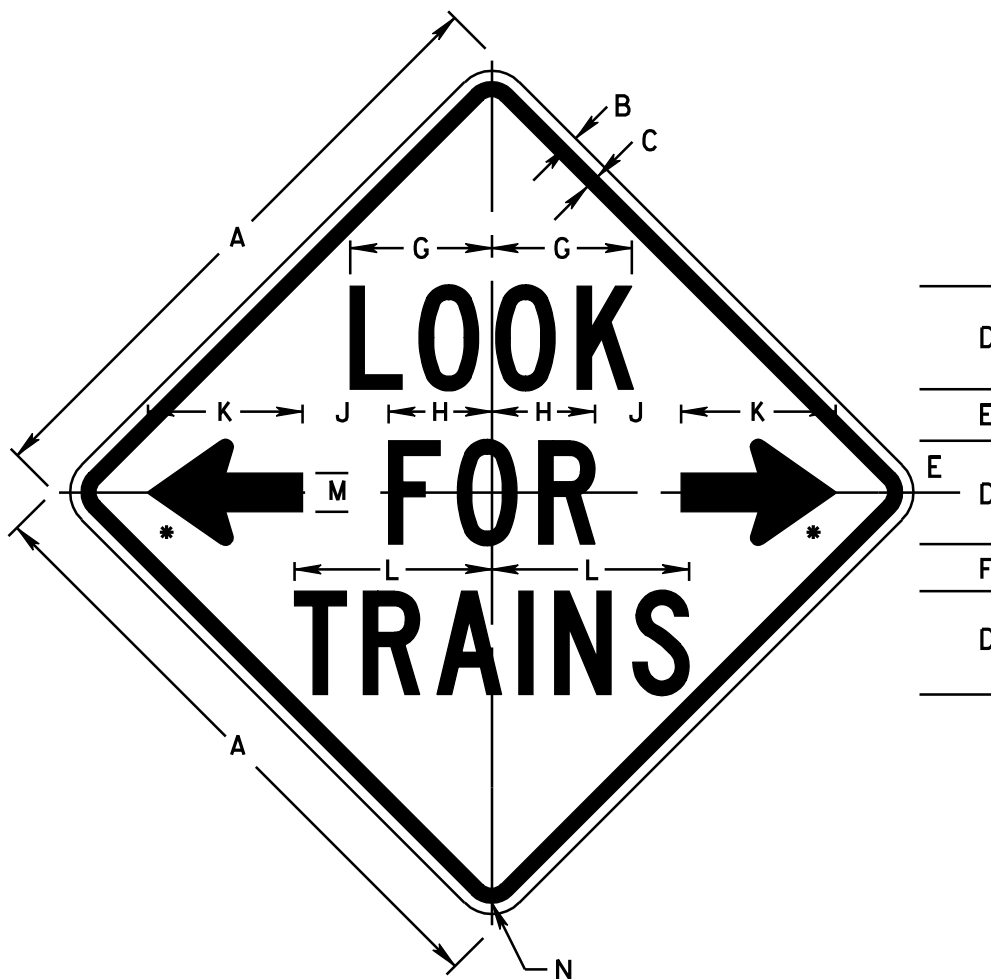

COLORS

LEGEND - BLACK (NON-REF)  
 BACKGROUND - YELLOW (REF)

DIMENSIONS (INCHES)

A	B	C	D	E	F	G	H	J	K	L	M	N
36	5/8	7/8	6C	3	2 3/4	8 1/4	6	5	9	11 7/16	2 1/4	1 5/8

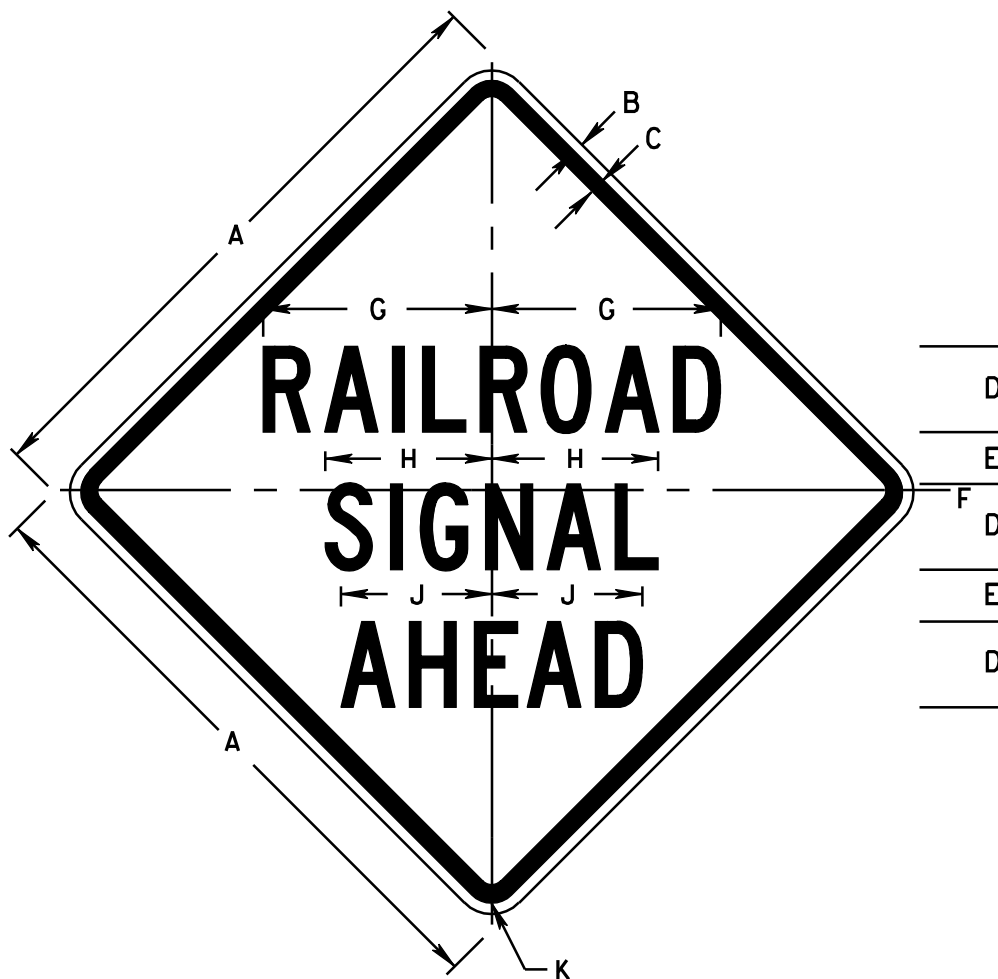

**COLORS**

LEGEND - BLACK (NON-REF)  
 BACKGROUND - YELLOW (REF)

**DIMENSIONS (INCHES)**

A	B	C	D	E	F	G	H	J	K
36	5/8	7/8	5C	3	1/2	1 3/4	9 11/16	8 3/4	1 5/8

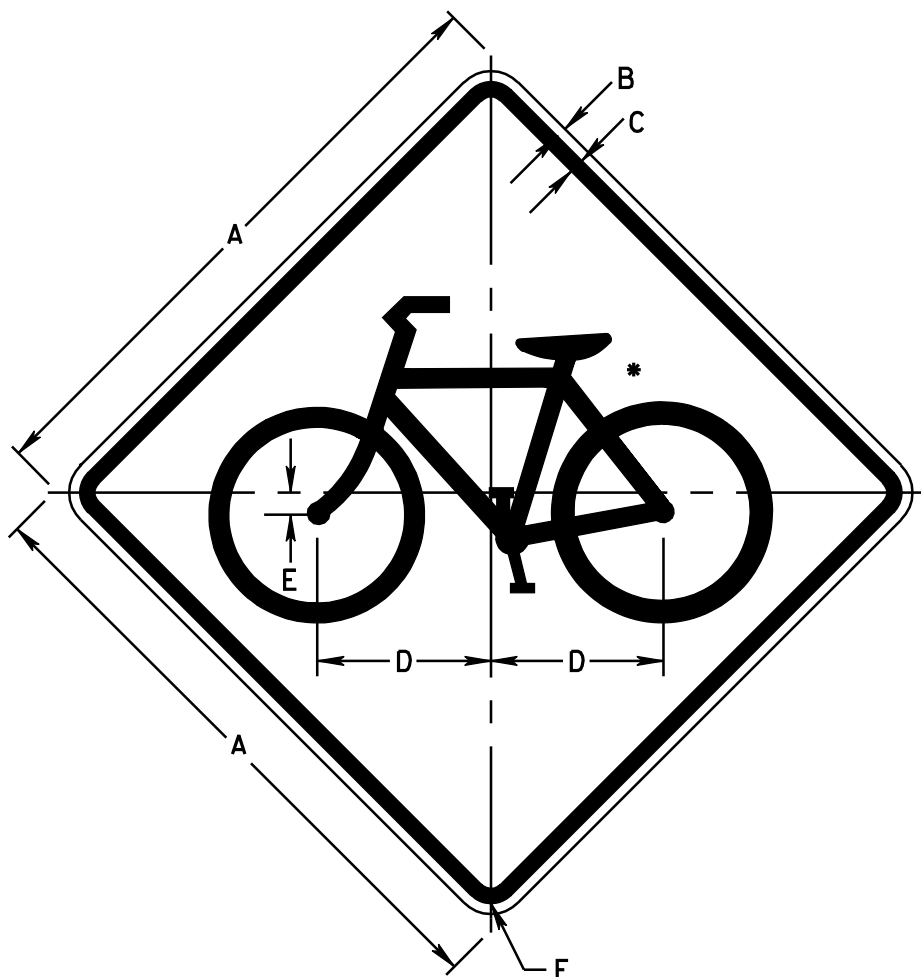

COLORS

LEGEND - BLACK (NON-REF)  
 BACKGROUND - YELLOW (REF)

DIMENSIONS (INCHES)

A	B	C	D	E	F
30	1/2	3/4	8 1/2	1	1 3/8
36	5/8	7/8	10	1 3/16	1 5/8

\* - SEE APPENDIX FOR SYMBOL DESIGN

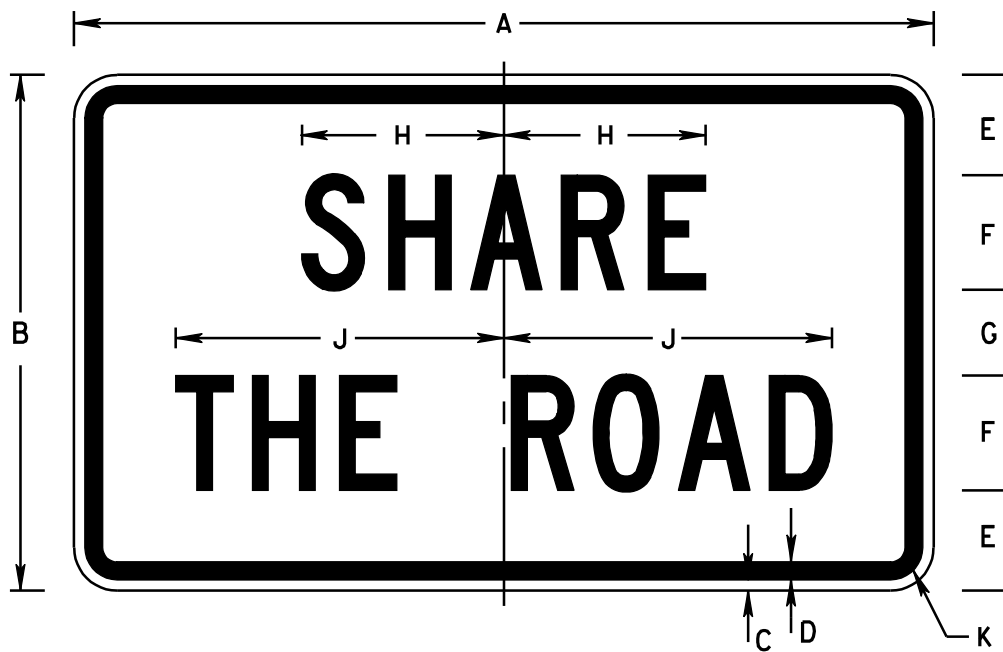

COLORS

LEGEND - BLACK (NON-REF)  
 BACKGROUND - YELLOW (REF)

DIMENSIONS (INCHES)

A	B	C	D	E	F	G	H	J	K
30	18	$\frac{3}{8}$	$\frac{5}{8}$	$3\frac{1}{2}$	4C	3	$7\frac{1}{16}$	$11\frac{7}{16}$	$1\frac{1}{8}$

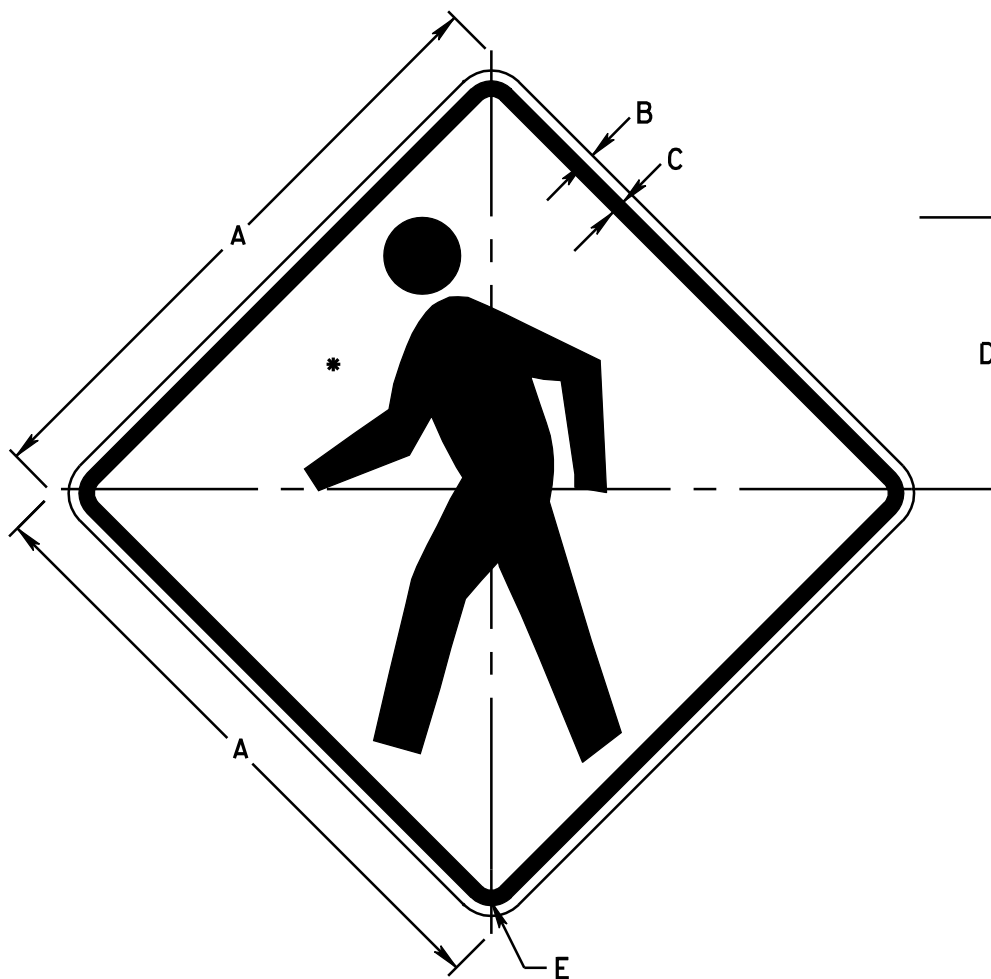

COLORS

LEGEND - BLACK (NON-REF)  
 BACKGROUND - YELLOW (REF)

DIMENSIONS (INCHES)

A	B	C	D	E
30	1/2	3/4	13 1/2	1 3/8
36	5/8	7/8	16	1 5/8
48	3/4	1 1/4	22	2 1/4

\* - SEE APPENDIX FOR SYMBOL DESIGN

W11-2 CODE	
30"	021115
36"	021116
48"	021117

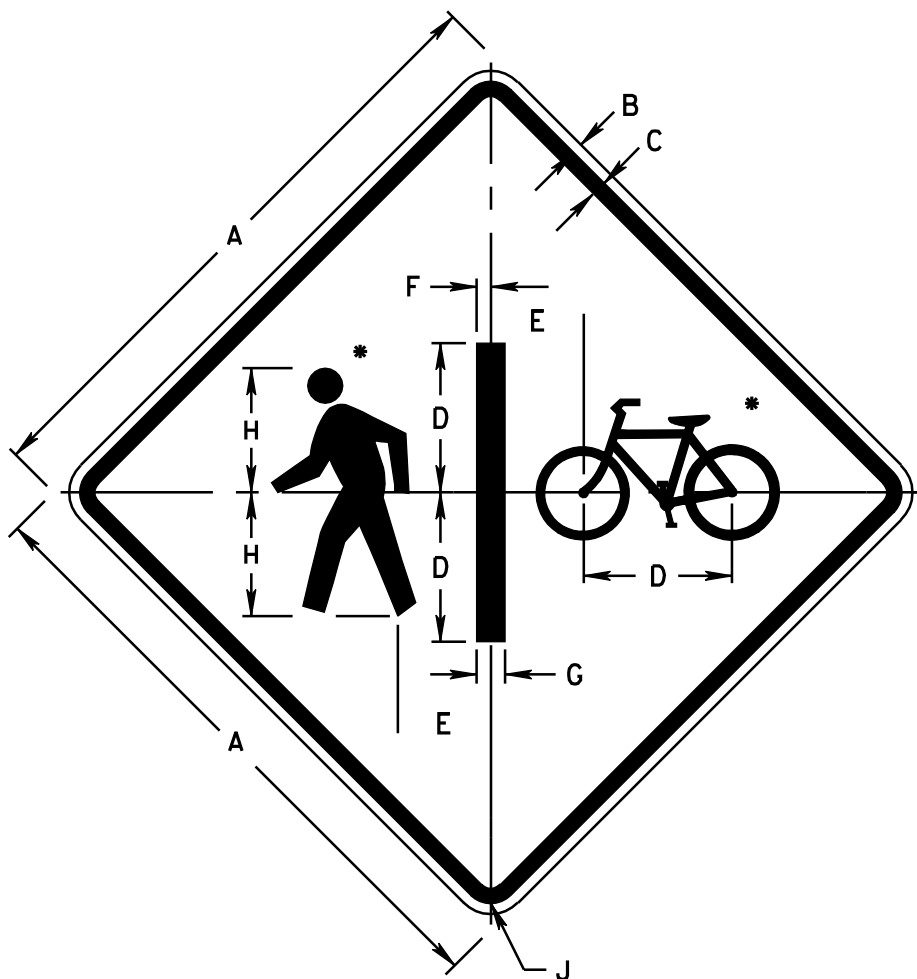

COLORS

LEGEND - BLACK (NON-REF)  
 BACKGROUND - YELLOW (REF)

DIMENSIONS (INCHES)

A	B	C	D	E	F	G	H	J
30	1/2	3/4	7 1/4	4 1/2	11/16	1 3/8	6	1 3/8

\* - SEE APPENDIX FOR SYMBOL DESIGN

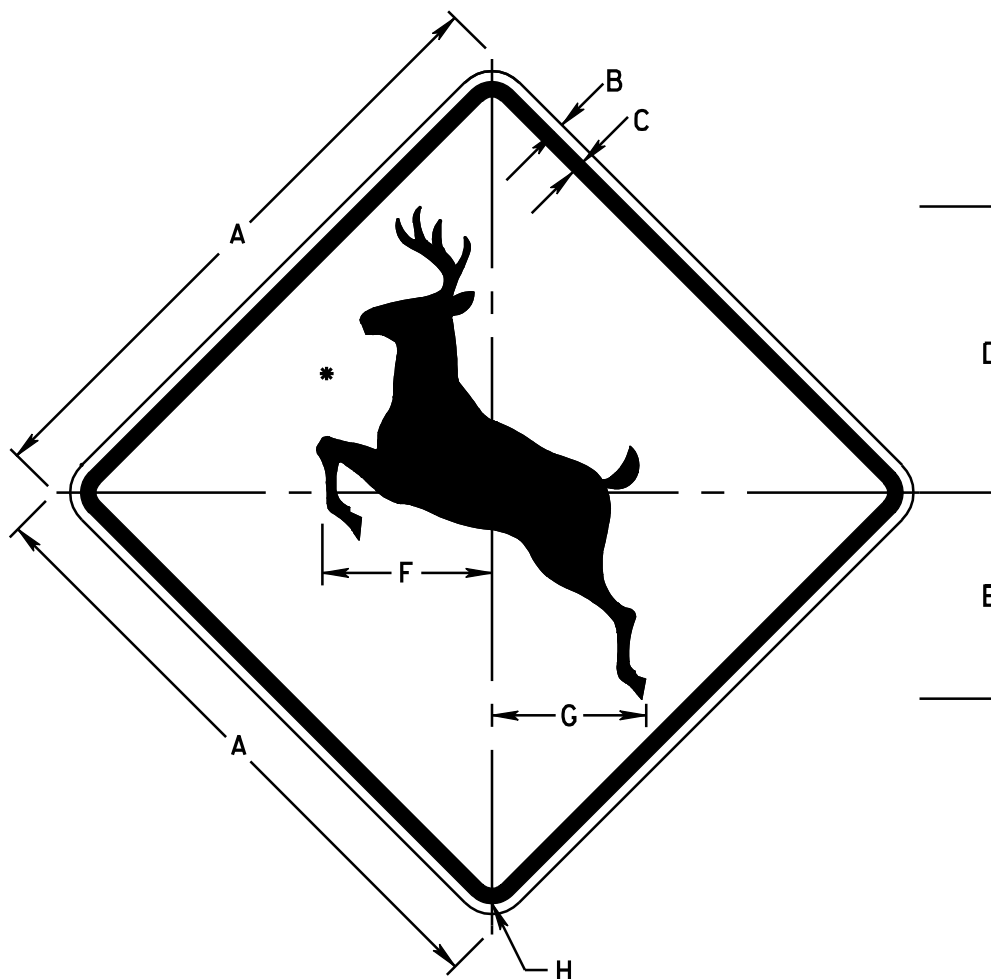

COLORS  
 LEGEND - BLACK (NON-REF)  
 BACKGROUND - YELLOW (REF)

DIMENSIONS (INCHES)

A	B	C	D	E	F	G	H
30	1/2	3/4	13 1/2	10	8 1/4	7 1/2	1 3/8
36	5/8	7/8	16 1/4	12	9 7/8	9	1 5/8
48	3/4	1 1/4	21 1/4	15 3/4	13	11 3/4	2 1/4

\* - SEE APPENDIX FOR SYMBOL DESIGN

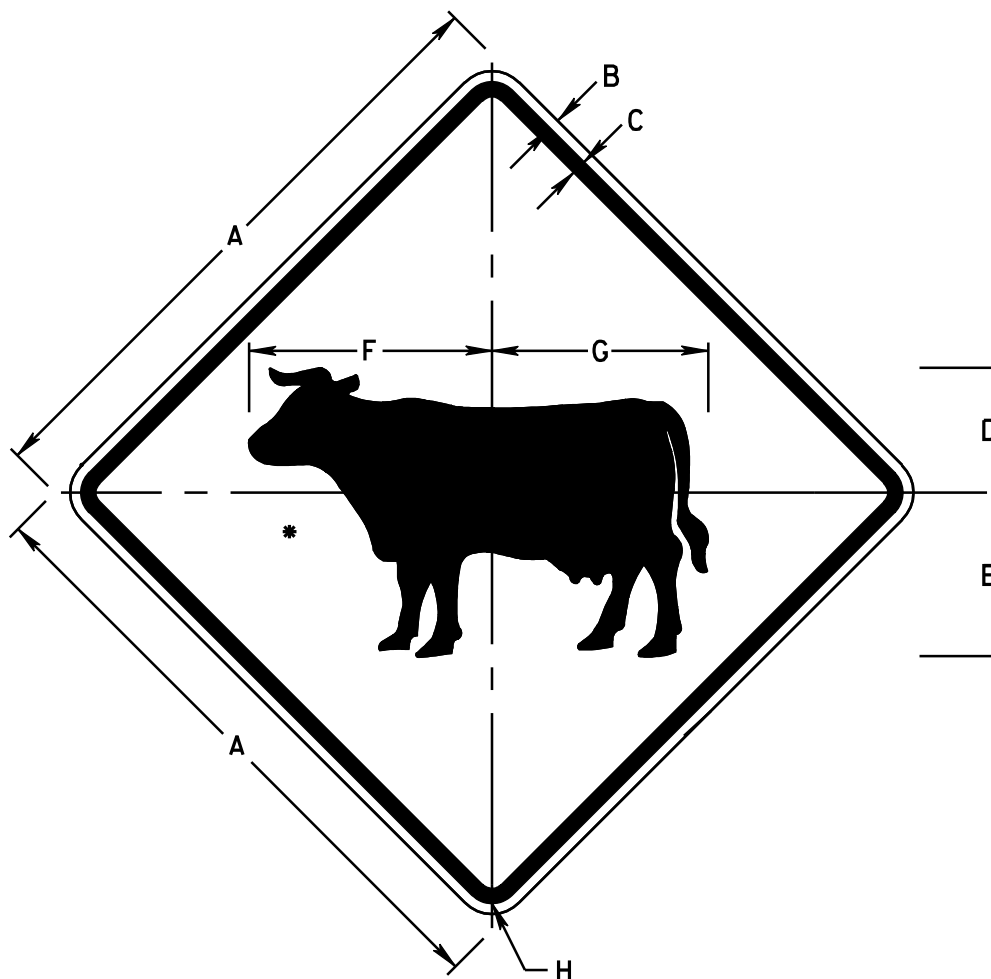

COLORS  
 LEGEND - BLACK (NON-REF)  
 BACKGROUND - YELLOW (REF)

DIMENSIONS (INCHES)

A	B	C	D	E	F	G	H
30	1/2	3/4	6	8	11 3/4	10 1/2	1 3/8
36	5/8	7/8	7 1/4	9 5/8	14 1/8	12 5/8	1 5/8

\* - SEE APPENDIX FOR SYMBOL DESIGN



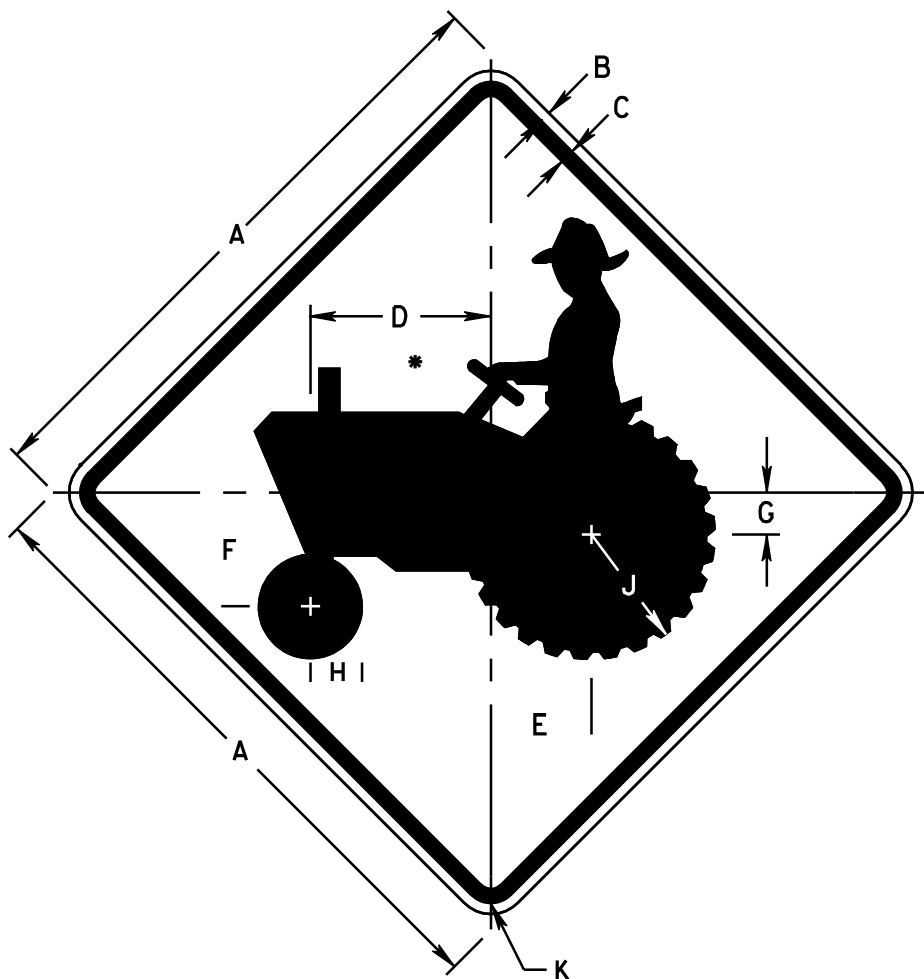

COLORS  
 LEGEND - BLACK (NON-REF)  
 BACKGROUND - YELLOW (REF)

DIMENSIONS (INCHES)

A	B	C	D	E	F	G	H	J	K
30	1/2	3/4	8 3/4	4 3/4	5 1/2	1 3/4	5	12	1 3/8
36	5/8	7/8	10 1/2	5 3/4	6 5/8	2 1/8	6	14 1/2	1 5/8

\* - SEE APPENDIX FOR SYMBOL DESIGN

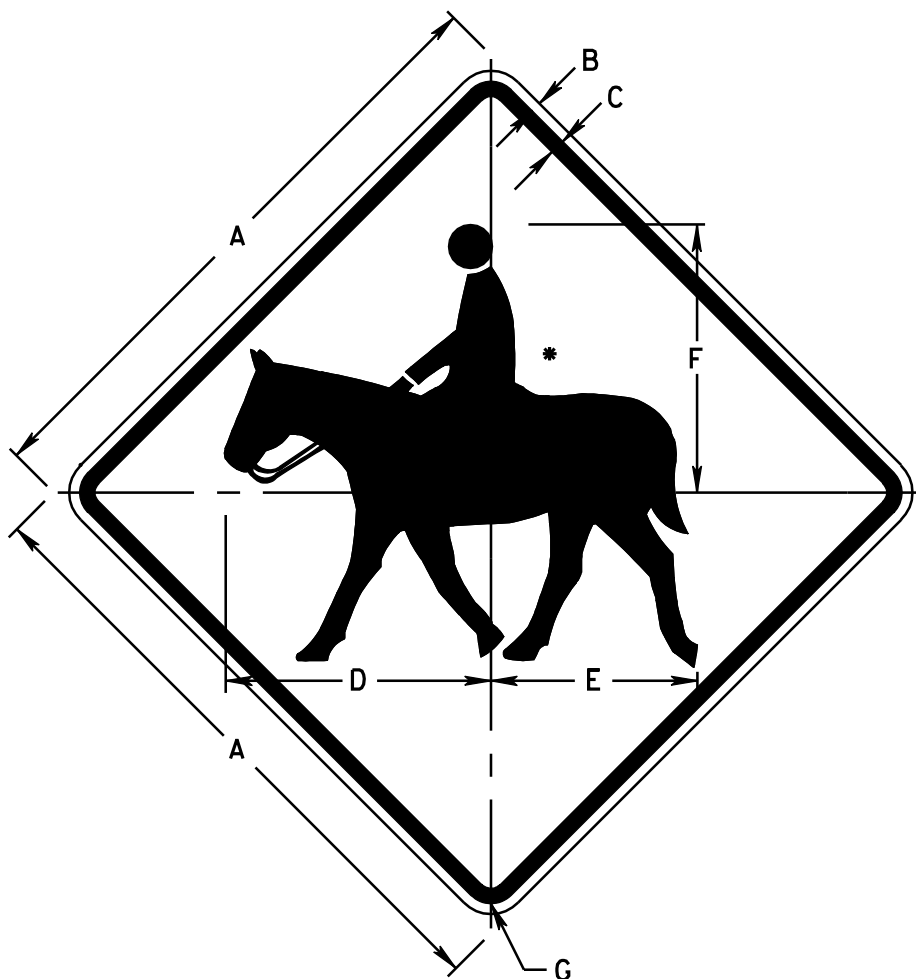

COLORS

LEGEND - BLACK (NON-REF)  
 BACKGROUND - YELLOW (REF)

DIMENSIONS (INCHES)

A	B	C	D	E	F	G
30	1/2	3/4	13	10	13	1 3/8
36	5/8	7/8	15 1/2	12	15 5/8	1 5/8

\* - SEE APPENDIX FOR SYMBOL DESIGN

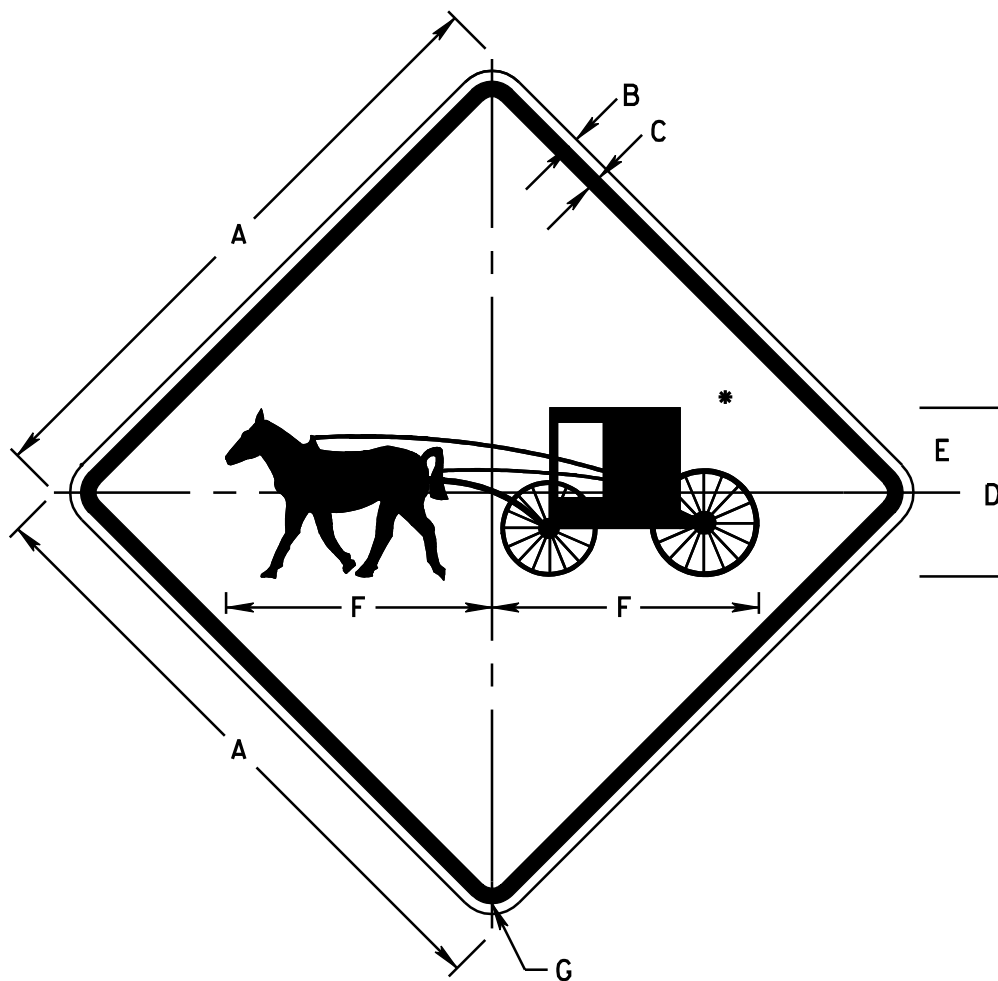

COLORS

LEGEND - BLACK (NON-REF)  
 BACKGROUND - YELLOW (REF)

DIMENSIONS (INCHES)

A	B	C	D	E	F	G
36	5/8	7/8	9 7/8	4 15/16	15 1/2	1 5/8

\* - SEE APPENDIX FOR SYMBOL DESIGN

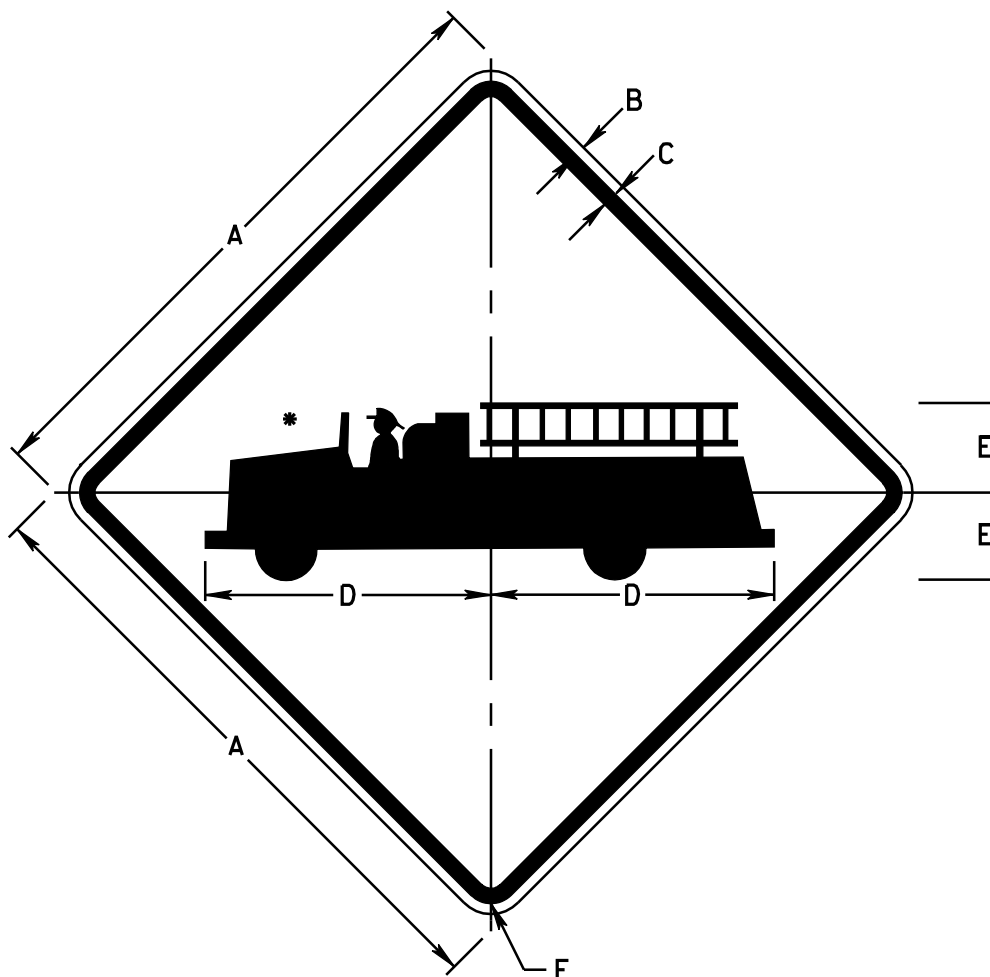

COLORS

LEGEND - BLACK (NON-REF)  
 BACKGROUND - YELLOW (REF)

DIMENSIONS (INCHES)

A	B	C	D	E	F
36	5/8	7/8	16 1/2	5 1/4	1 5/8
48	3/4	1 1/4	22	7	2 1/4

\* - SEE APPENDIX FOR SYMBOL DESIGN

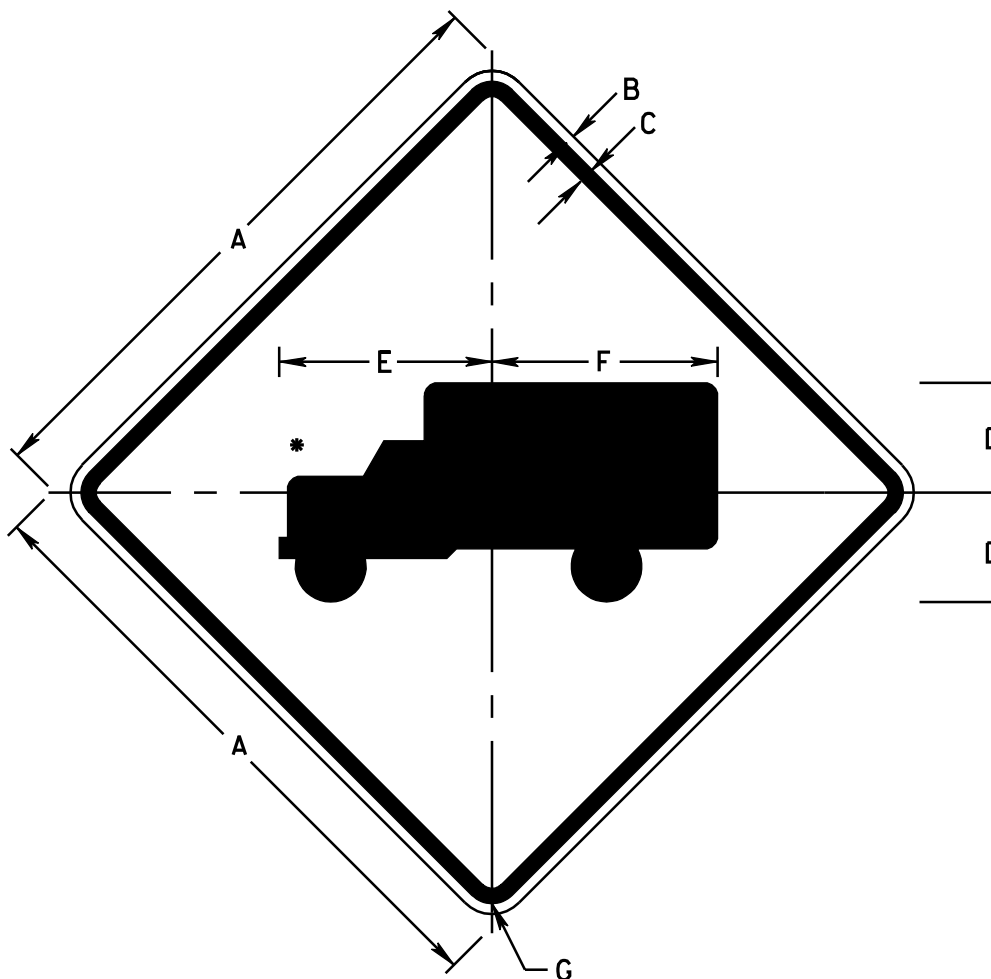

COLORS

LEGEND - BLACK (NON-REF)  
 BACKGROUND - YELLOW (REF)

DIMENSIONS (INCHES)

A	B	C	D	E	F	G
30	1/2	3/4	5 5/16	11 1/4	10	1 3/8
36	5/8	7/8	6 3/8	13 1/2	12	1 5/8
48	3/4	1 1/4	8 1/2	18	16	2 1/4

\* - SEE APPENDIX FOR SYMBOL DESIGN

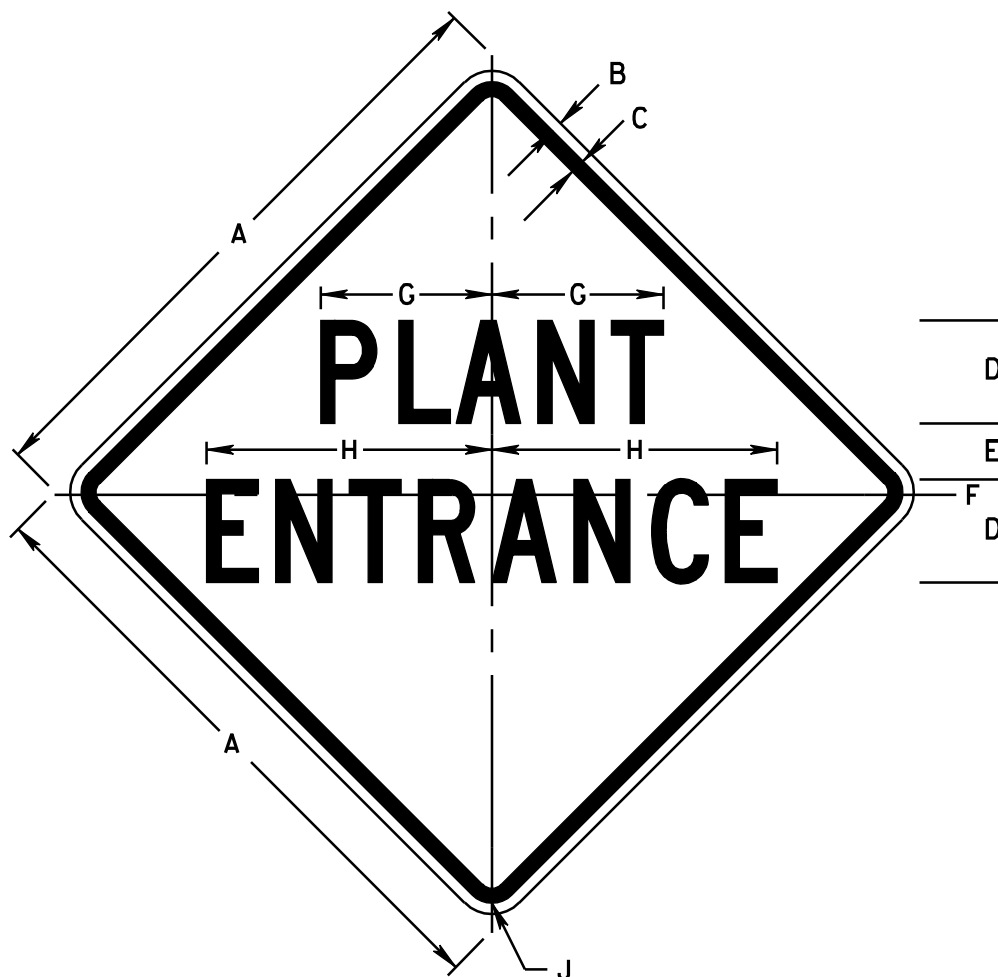

**COLORS**

LEGEND - BLACK (NON-REF)  
 BACKGROUND - YELLOW (REF)

**DIMENSIONS (INCHES)**

A	B	C	D	E	F	G	H	J
30	1/2	3/4	5C	3 1/2	1/2	8 5/16	13 13/16	1 3/8
36	5/8	7/8	6C	4	3/4	9 15/16	16 9/16	1 5/8

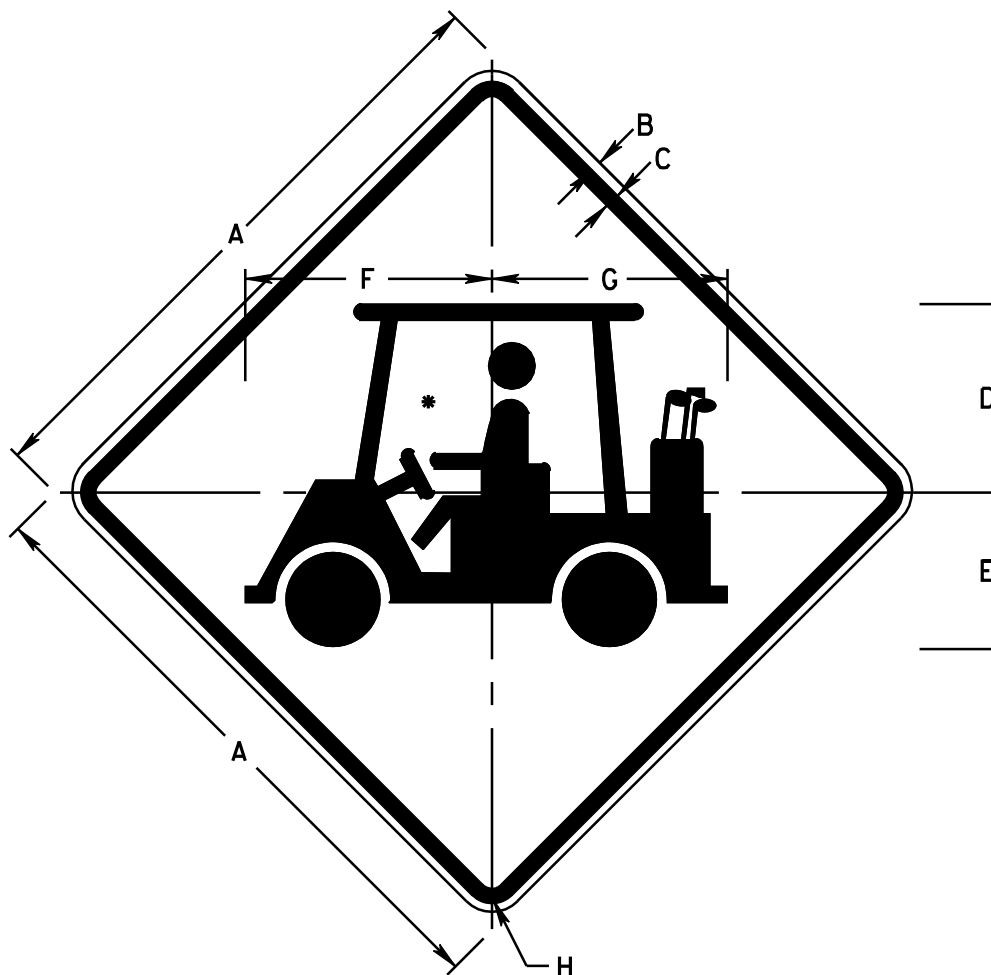

**COLORS**

LEGEND - BLACK (NON-REF)  
 BACKGROUND - YELLOW (REF)

**DIMENSIONS (INCHES)**

A	B	C	D	E	F	G	H
30	1/2	3/4	9 1/8	7 5/8	11 7/8	11 1/2	1 3/8
36	5/8	7/8	10 15/16	9 1/8	14 1/4	13 3/4	1 5/8
48	3/4	1 1/4	14 1/2	12 1/8	18 15/16	18 1/4	2 1/4

\* - SEE APPENDIX FOR SYMBOL DESIGN

W11-11 CODE	
30"	
36"	
48"	

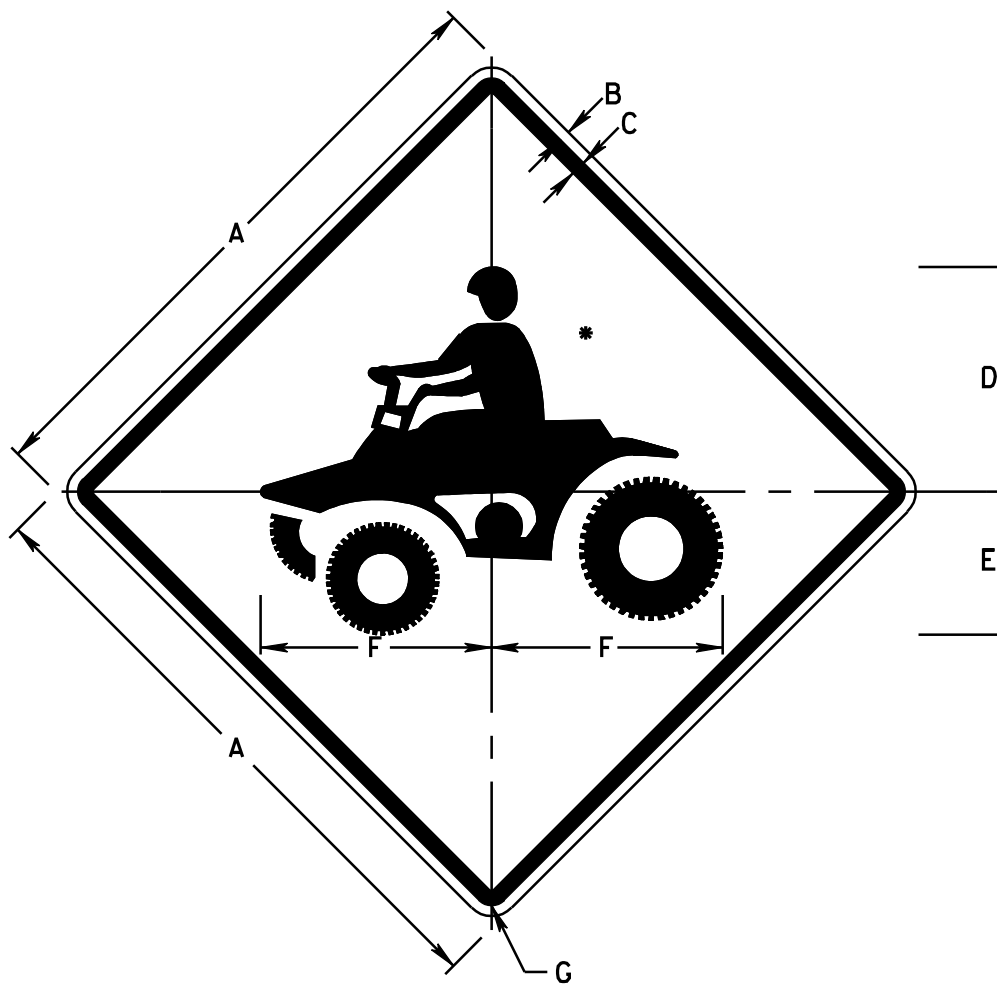

COLORS  
 LEGEND - BLACK (NON-REF)  
 BACKGROUND - YELLOW (REF)

DIMENSIONS (INCHES)

A	B	C	D	E	F	G
30	1/2	3/4	10 15/16	6 15/16	11 1/4	1 3/8

\* - SEE APPENDIX FOR SYMBOL DESIGN



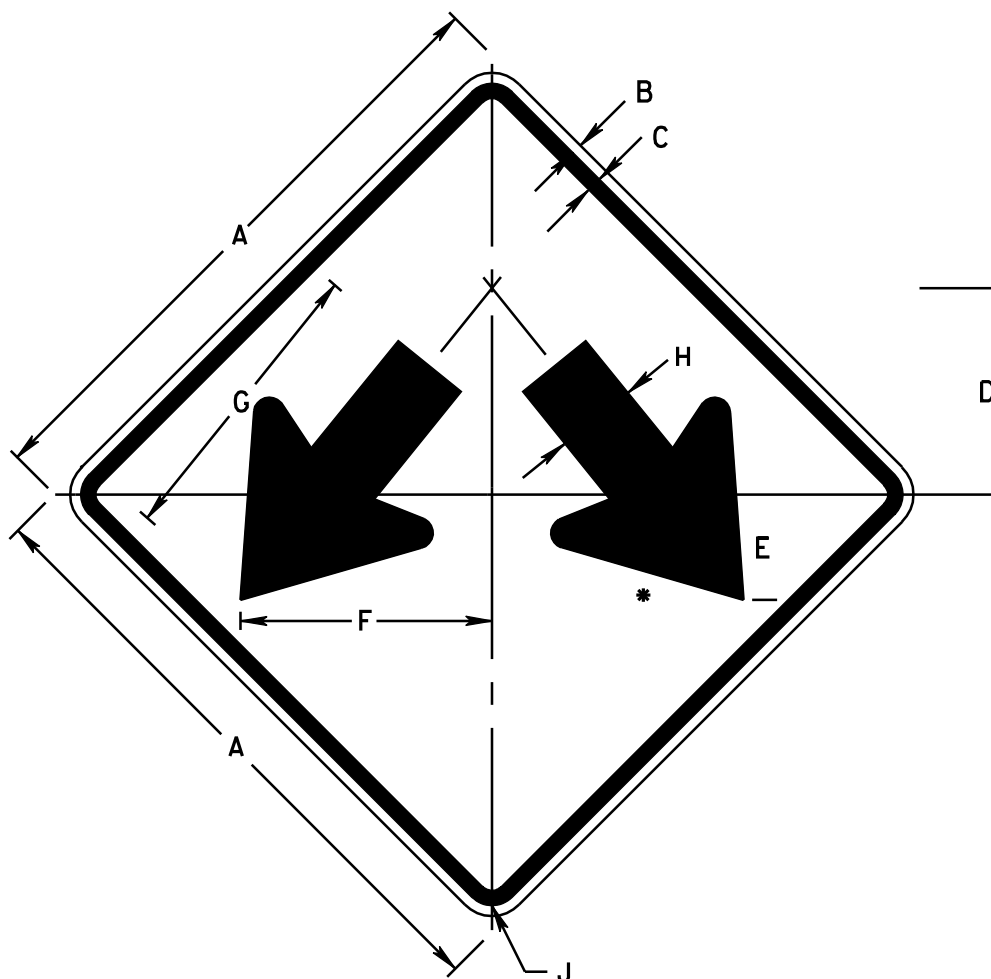

COLORS

LEGEND - BLACK (NON-REF)  
 BACKGROUND - YELLOW (REF)

DIMENSIONS (INCHES)

A	B	C	D	E	F	G	H	J
30	1/2	3/4	10	5 1/4	12 3/8	14 11/16	4	1 3/8
36	5/8	7/8	12	6 1/8	14 5/8	17 1/2	4 3/4	1 5/8

\* - SEE APPENDIX FOR ARROW DESIGN  
 WHEN USED IN CONSTRUCTION OR MAINTENANCE OPERATIONS  
 THE SIGN SHALL HAVE AN ORANGE REFLECTIVE BACKGROUND,  
 AND SHALL HAVE THE SUFFIX "M" ADDED TO THE FABRICATION NUMBER.

W12-1 CODE	W12-1M CODE
30" 021202	30"
36" 021203	36"

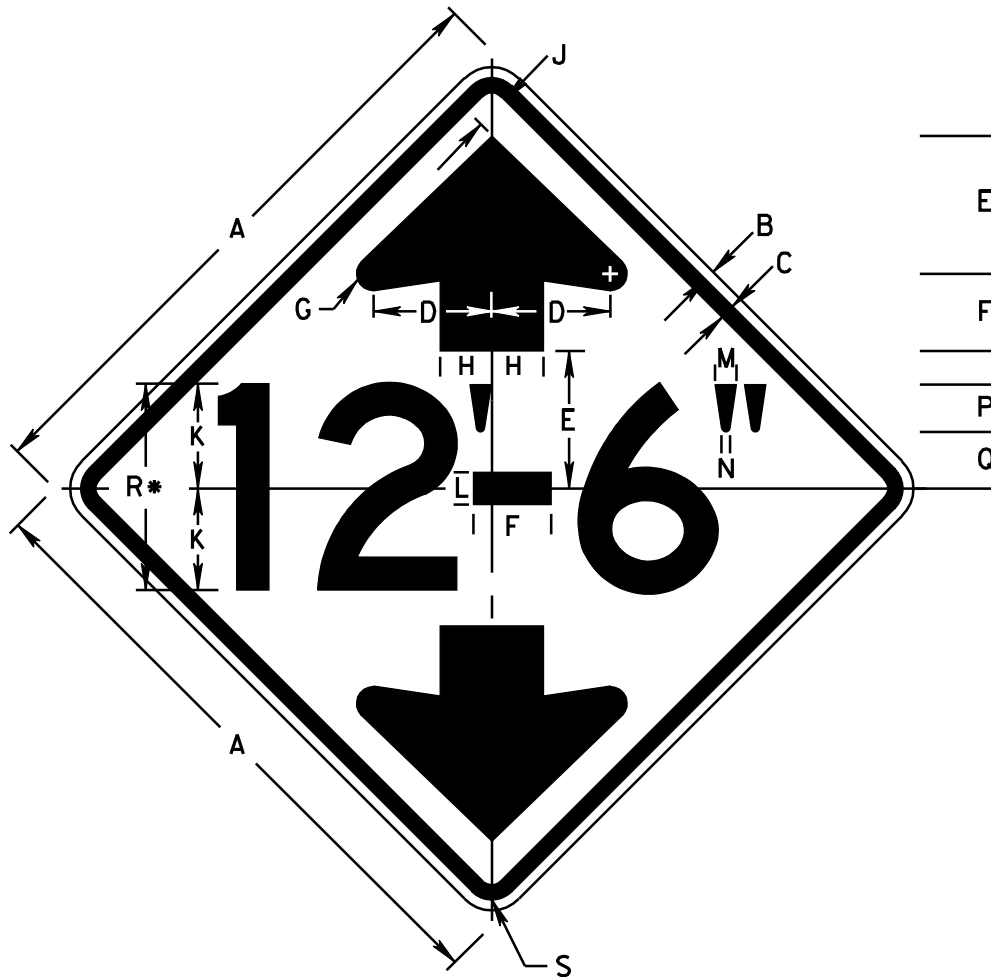

**COLORS**

LEGEND - BLACK (NON-REF)  
 BACKGROUND - YELLOW (REF)

**DIMENSIONS (INCHES)**

A	B	C	D	E	F	G	H	J	K	L	M	N	P	Q	R	S
30	1/2	3/4	5 3/4	6 5/8	3 3/4	3/4	2 1/2	1 1/16	5	1 9/16	1	7/16	2 1/4	3 5/16	10D	1 3/8
36	5/8	7/8	6 7/8	8	4 1/2	1	3	2	6	1 7/8	1 1/4	1/2	2 3/4	4	12D	1 5/8
48	3/4	1 1/4	9 3/16	10 5/8	5 7/8	1 5/16	4	2 5/8	8	2 7/16	1 5/8	5/8	3 5/8	5 1/2	16D	2 1/4

\* - OPTICALLY SPACE NUMERALS ABOUT VERTICAL CENTERLINE (WHERE 10" IS PART OF VERTICAL CLEARANCE, USE SERIES C NUMERALS)  
 36" AND 48" - WHEN USED IN CONSTRUCTION OR MAINTENANCE OPERATIONS THE SIGN SHALL HAVE AN ORANGE REFLECTIVE BACKGROUND, AND SHALL HAVE THE SUFFIX "M" ADDED TO THE FABRICATION NUMBER.

WV DEPARTMENT OF TRANSPORTATION  
 DIVISION OF HIGHWAYS  
 TRAFFIC ENGINEERING DIVISION

W12-2 CODE	
30"	021209
36"	021210
48"	021211
36" M	
48" M	

**W12-2**

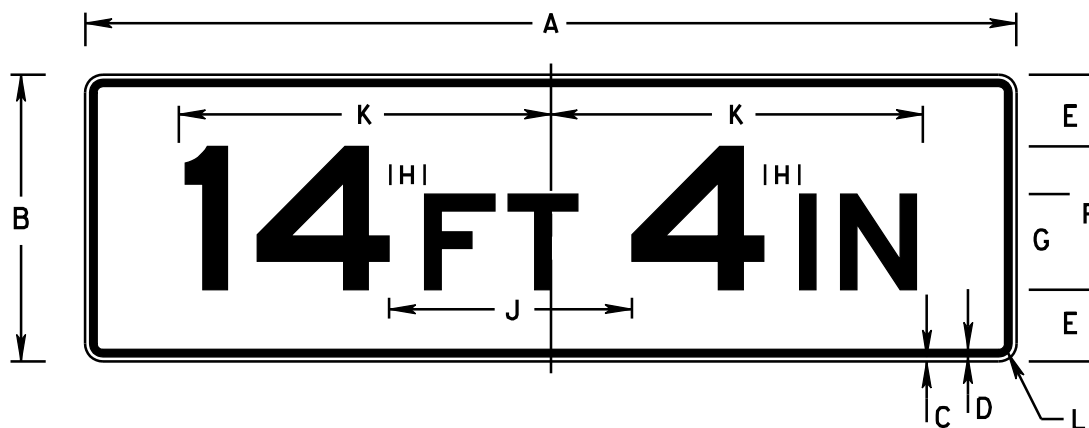

COLORS

LEGEND - BLACK (NON-REF)  
 BACKGROUND - YELLOW (REF)

DIMENSIONS (INCHES)

A	B	C	D	E	F	G	H	J	K	L
78	24	3/8	5/8	6	12E	8E	3	20 5/16	30 5/8	1 1/8

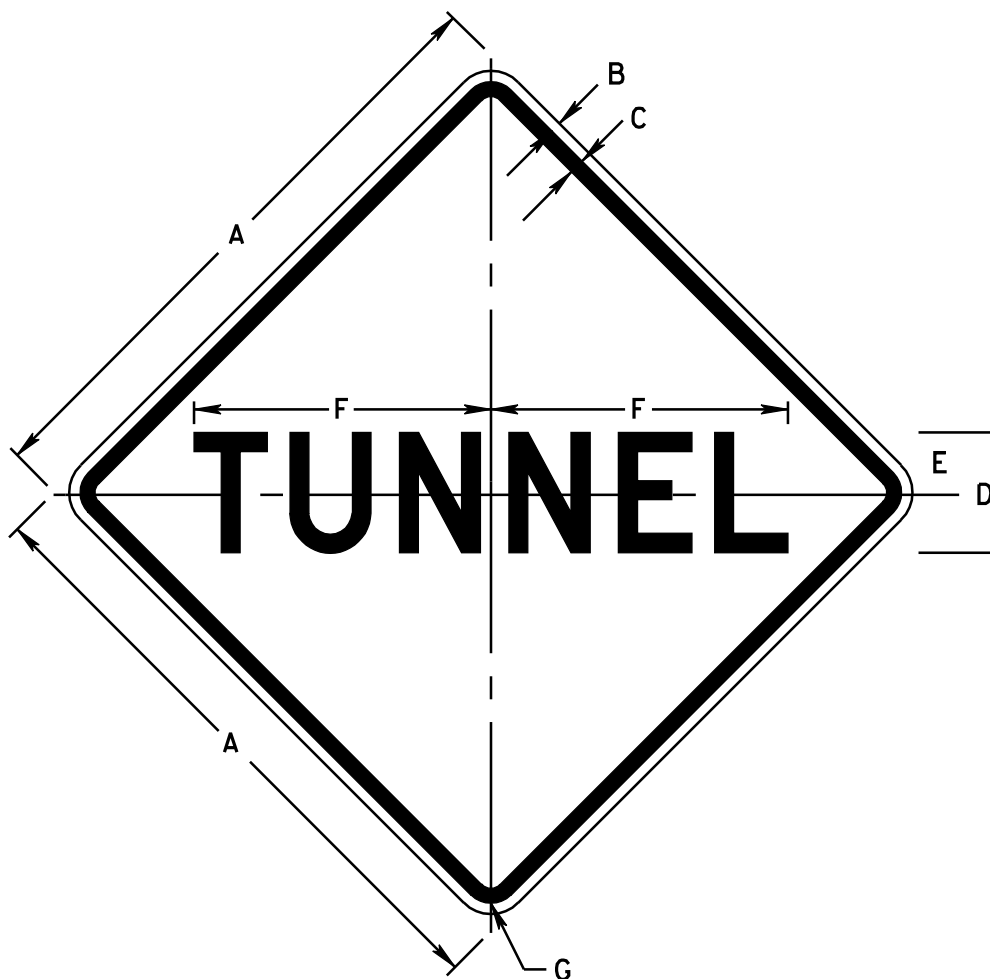

**COLORS**

LEGEND - BLACK (NON-REF)  
 BACKGROUND - YELLOW (REF)

**DIMENSIONS (INCHES)**

A	B	C	D	E	F	G
36	5/8	7/8	7D	3 1/2	17	1 5/8
48	3/4	1 1/4	10D	5	24 9/16	2 1/4

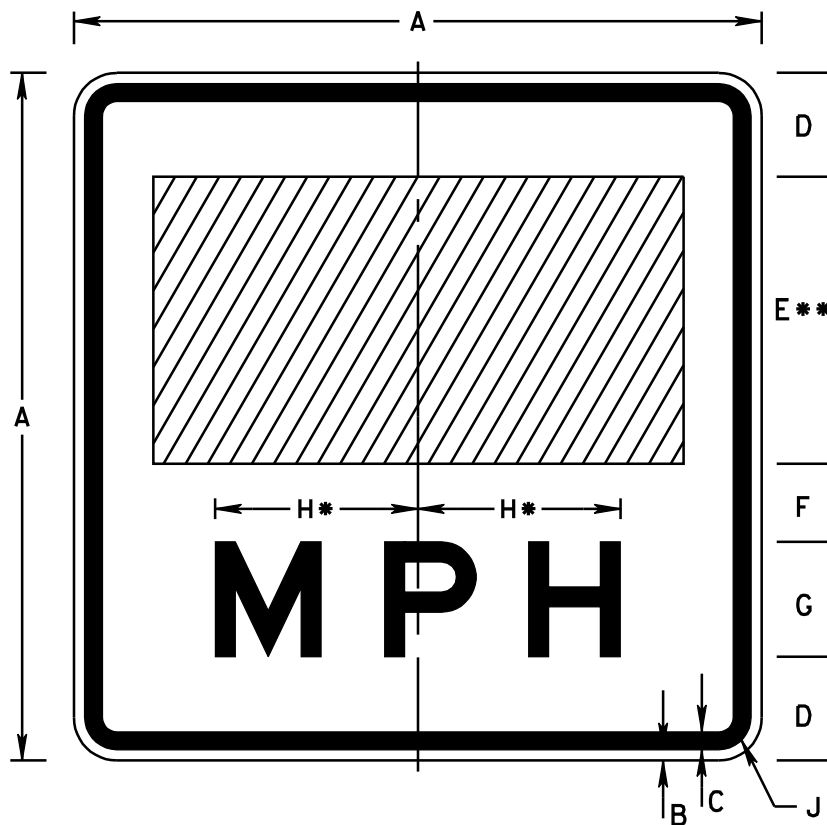

**COLORS**

LEGEND - BLACK (NON-REF)  
 BACKGROUND - YELLOW (REF)

**DIMENSIONS (INCHES)**

A	B	C	D	E	F	G	H	J
18	3/8	5/8	2 1/2	8E	2	3E	5 5/16	1 1/8
24	3/8	5/8	3 5/8	10E	2 3/4	4E	7 1/16	1 1/8

\* - INCREASE SPACING 100%

\*\* - OPTICALLY SPACE NUMERALS ABOUT VERTICAL CENTERLINE.

ADVISORY SPEED OF 30 MPH OR LESS WILL BE FABRICATED IN 24" SIZE ONLY.

24" - WHEN USED IN CONSTRUCTION OR MAINTENANCE OPERATIONS

THE SIGN SHALL HAVE AN ORANGE REFLECTIVE BACKGROUND,  
 AND SHALL HAVE THE SUFFIX "M" ADDED TO THE FABRICATION NUMBER.

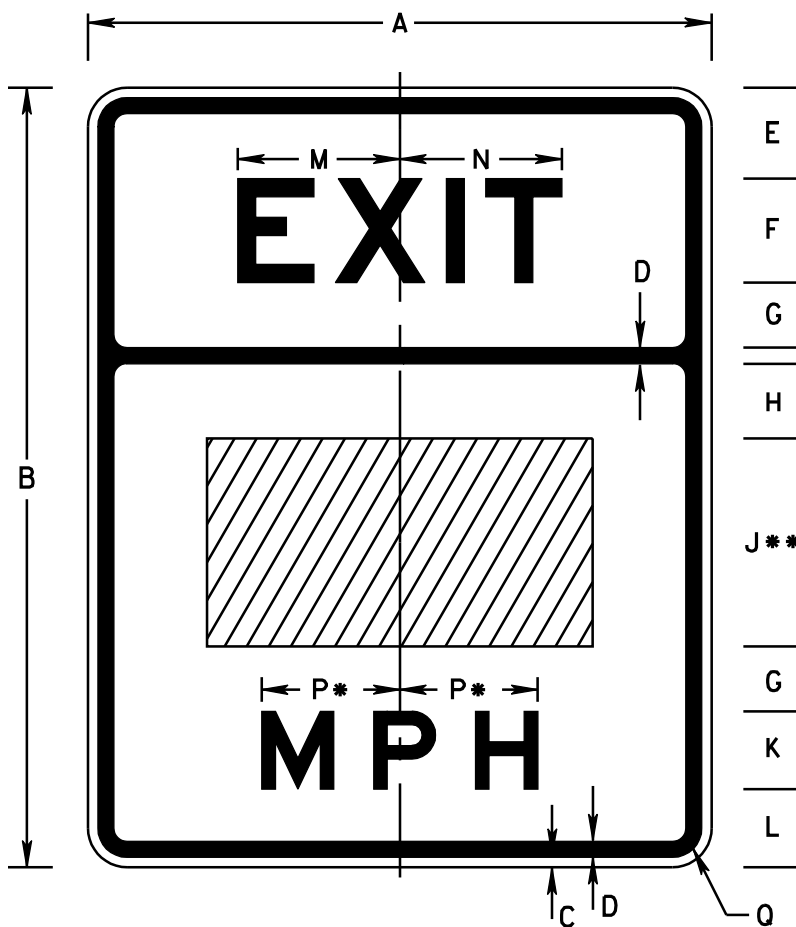

**COLORS**

LEGEND - BLACK (NON-REF)  
 BACKGROUND - YELLOW (REF)

**DIMENSIONS (INCHES)**

A	B	C	D	E	F	G	H	J	K	L	M	N	P	Q
48	60	3/4	1 1/4	7	8E	5	5 3/4	16E	6E	6	12 1/4	12 3/4	10 5/8	2 1/4

\* - INCREASE SPACING 100%

\*\* - OPTICALLY SPACE NUMERALS ABOUT VERTICAL CENTERLINE.

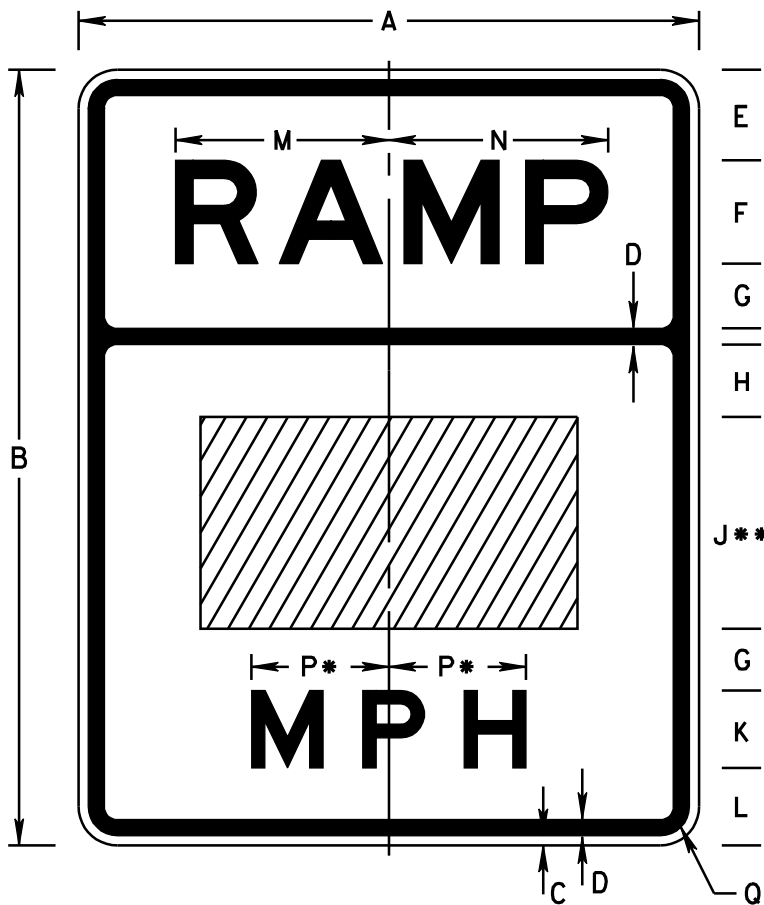

**COLORS**

LEGEND - BLACK (NON-REF)  
 BACKGROUND - YELLOW (REF)

**DIMENSIONS (INCHES)**

A	B	C	D	E	F	G	H	J	K	L	M	N	P	Q
24	30	3/8	5/8	3 1/2	4E	2 1/2	2 7/8	8E	3E	3	8 1/4	8 1/2	5 5/16	1 1/8
36	48	5/8	7/8	6	6E	4	5 1/8	12E	4E	6	12 3/8	12 3/4	7 1/16	1 5/8
48	60	3/4	1 1/4	7	8E	5	5 3/4	16E	6E	6	16 1/2	17	10 5/8	2 1/4

\* - INCREASE SPACING 100%

\*\* - OPTICALLY SPACE NUMERALS ABOUT VERTICAL CENTERLINE.

W13-3 CODE	
24"x30"	
36"x48"	
48"x60"	021315

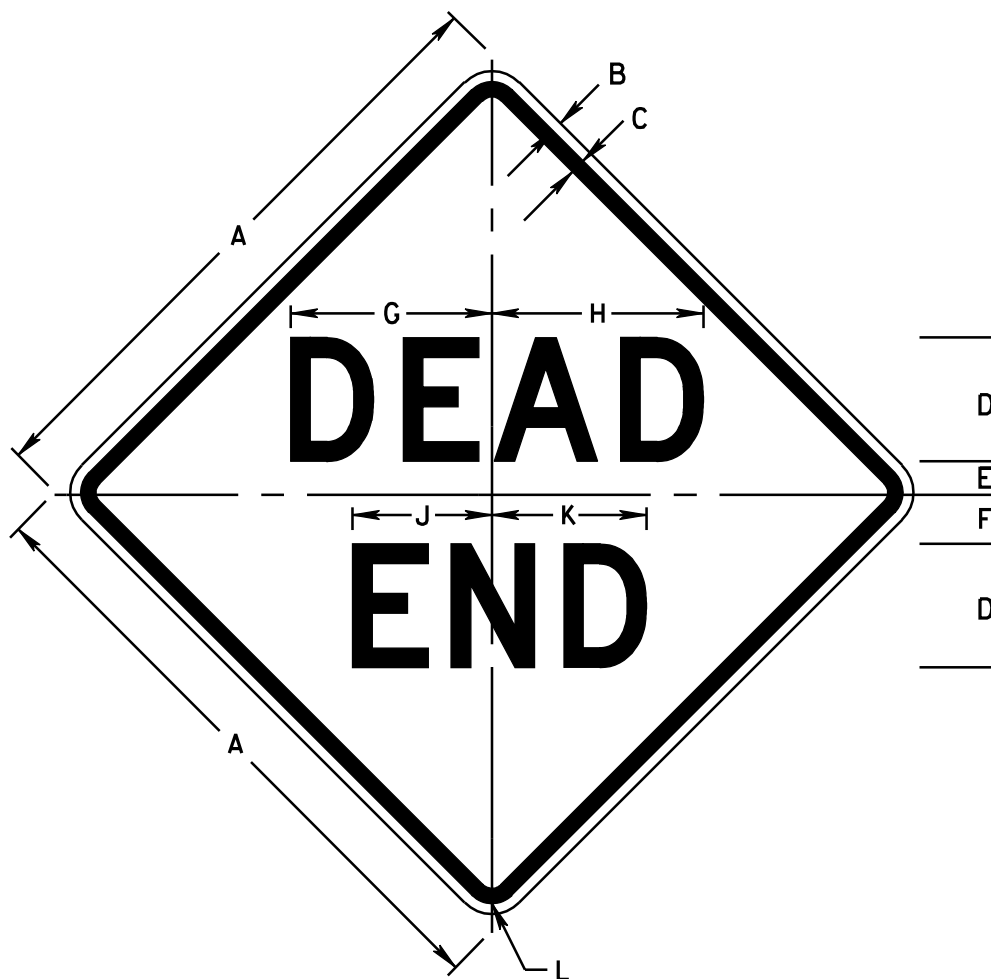

**COLORS**

LEGEND - BLACK (NON-REF)  
 BACKGROUND - YELLOW (REF)

**DIMENSIONS (INCHES)**

A	B	C	D	E	F	G	H	J	K	L
30	1/2	3/4	6D	1 1/2	2 1/2	9 3/4	10 1/4	6 3/4	7 1/2	1 3/8
36	5/8	7/8	7D	2	3	11 3/8	11 15/16	7 7/8	8 3/4	1 5/8



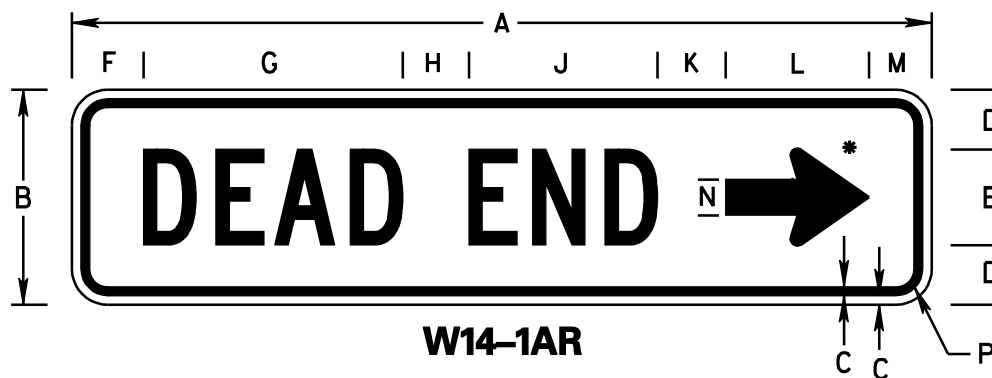

COLORS

LEGEND - BLACK (NON-REF)  
BACKGROUND - YELLOW (REF)

DIMENSIONS (INCHES)

A	B	C	D	E	F	G	H	J	K	L	M	N	P
30	6	3/8	1 1/2	3C	3	8 1/8	2 3/4	5 5/16	2 3/4	4 1/2	3	1 1/8	1 1/8
36	9	3/8	2 1/2	4C	3	10 7/8	2 7/8	8 1/16	2 11/16	6	2 5/8	1 1/2	1 1/8

\* - SEE APPENDIX FOR ARROW DESIGN

W14-1AR CODE	
30"x6"	
36"x9"	
W14-1AL CODE	
30"x6"	
36"x9"	

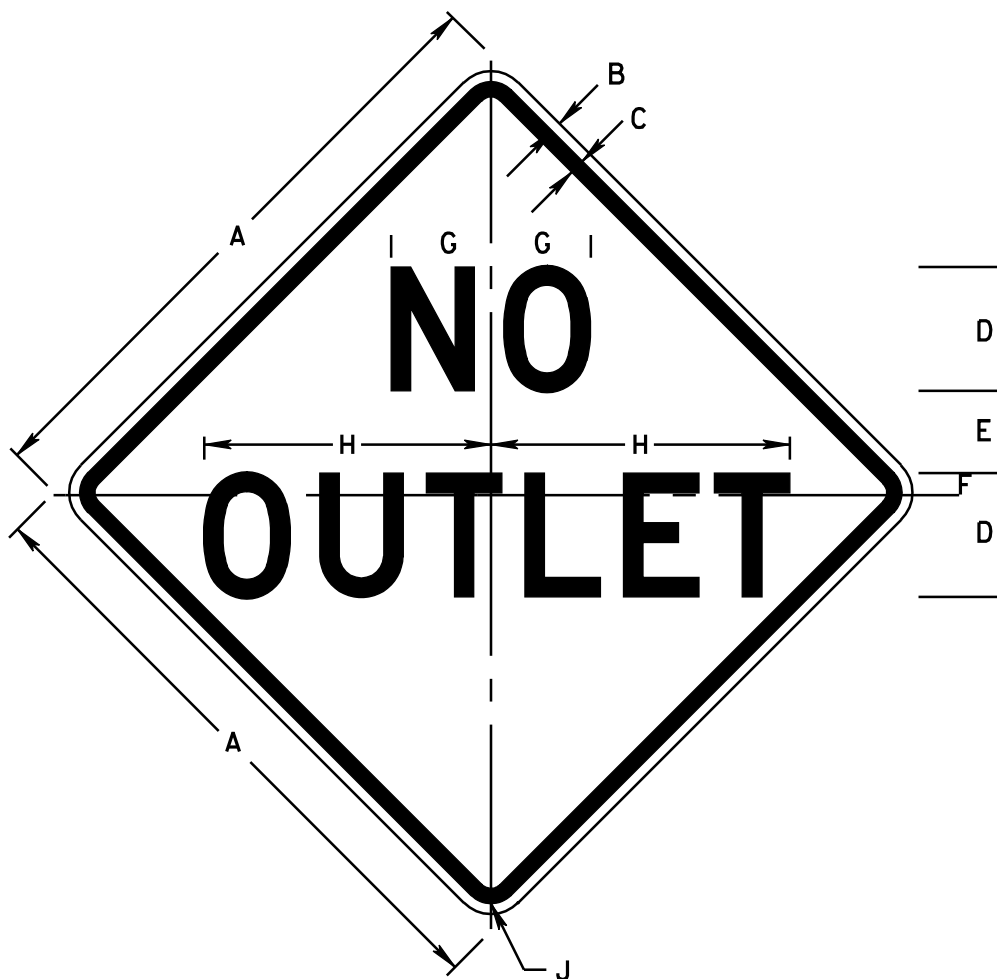

**COLORS**

LEGEND - BLACK (NON-REF)  
 BACKGROUND - YELLOW (REF)

**DIMENSIONS (INCHES)**

A	B	C	D	E	F	G	H	J
30	1/2	3/4	6D	4	15/16	5 3/16	14 3/16	1 3/8
36	5/8	7/8	7D	5	1 1/8	6 1/16	16 9/16	1 5/8

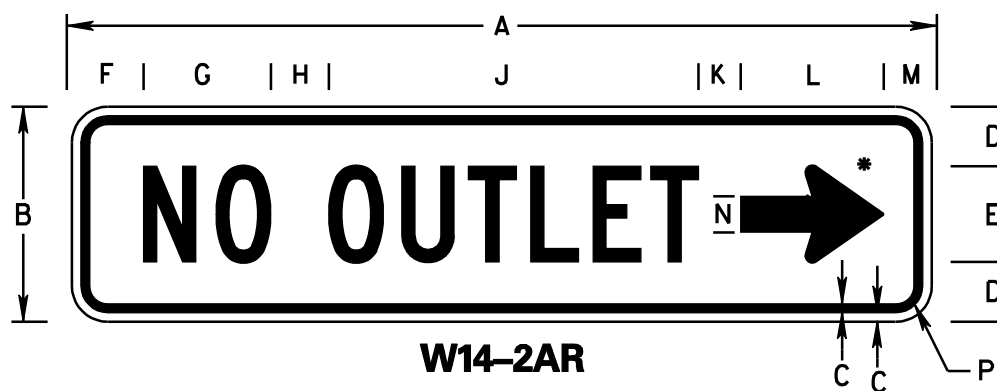

W14-2AL

COLORS

LEGEND - BLACK (NON-REF)  
 BACKGROUND - YELLOW (REF)

DIMENSIONS (INCHES)

A	B	C	D	E	F	G	H	J	K	L	M	N	P
30	6	3/8	1 1/2	3C	2 5/16	4	2 1/2	11 7/8	2 1/2	4 1/2	2 5/16	1 1/8	1 1/8
36	9	3/8	2 1/2	4C	3	5 3/8	2 3/8	15 1/2	1 3/4	6	2	1 1/2	1 1/8

\* - SEE APPENDIX FOR ARROW DESIGN

W14-2AR CODE	
30"x6"	
36"x9"	
W14-2AL CODE	
30"x6"	
36"x9"	



**COLORS**

LEGEND - BLACK (NON-REF)  
 BACKGROUND - YELLOW (REF)

**DIMENSIONS (INCHES)**

A	B	C	D	E	F	G	H	J	K	L	M	N
48	36	5/8	7/8	8 1/2	5D	5C	2	3	8	26 13/16	12 3/4	1 5/8

\* - REDUCE SPACING 20%

\*\* - REDUCE SPACING 35%

WHEN USED IN CONSTRUCTION OR MAINTENANCE OPERATIONS  
 THE SIGN SHALL HAVE AN ORANGE REFLECTIVE BACKGROUND,  
 AND SHALL HAVE THE SUFFIX "M" ADDED TO THE FABRICATION NUMBER.

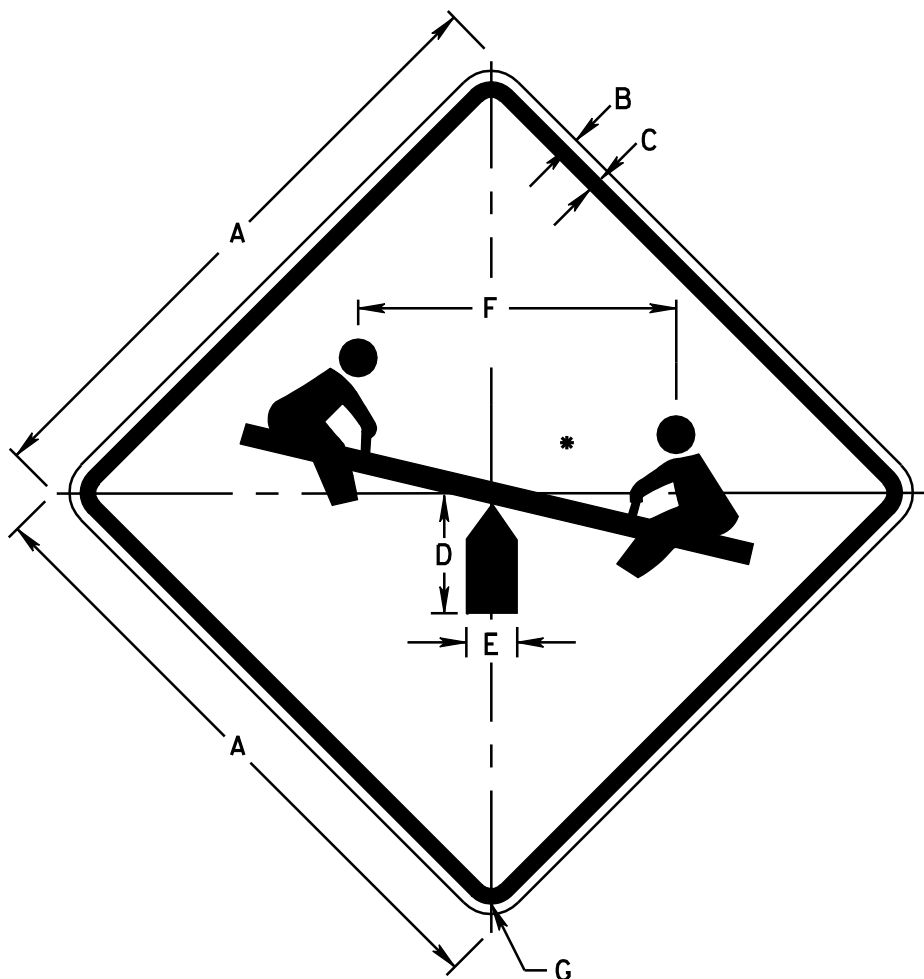

COLORS

SYMBOL - BLACK (NON-REF)  
 BACKGROUND - YELLOW (REF)

DIMENSIONS (INCHES)

A	B	C	D	E	F	G
30	1/2	3/4	5 3/4	2 1/2	15 1/2	1 3/8
36	5/8	7/8	7	3	18 5/8	1 5/8

\* - SEE APPENDIX FOR SYMBOL DESIGN  
 TO BE USED IN CONJUNCTION WITH W15-101

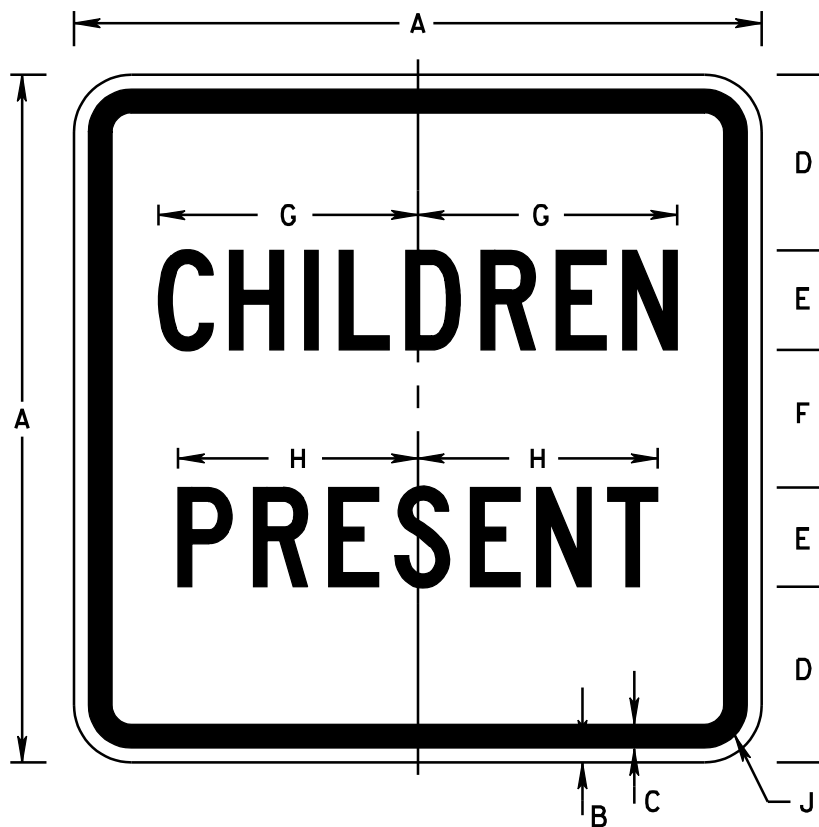

COLORS

LEGEND - BLACK (NON-REF)  
 BACKGROUND - YELLOW (REF)

DIMENSIONS (INCHES)

A	B	C	D	E	F	G	H	J
18	$\frac{3}{8}$	$\frac{5}{8}$	$2\frac{5}{8}$	$2\frac{5}{8}$	$2\frac{1}{2}$	$6\frac{13}{16}$	$6\frac{5}{16}$	$1\frac{1}{8}$

TO BE USED IN CONJUNCTION WITH W15-1

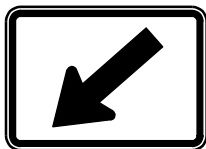
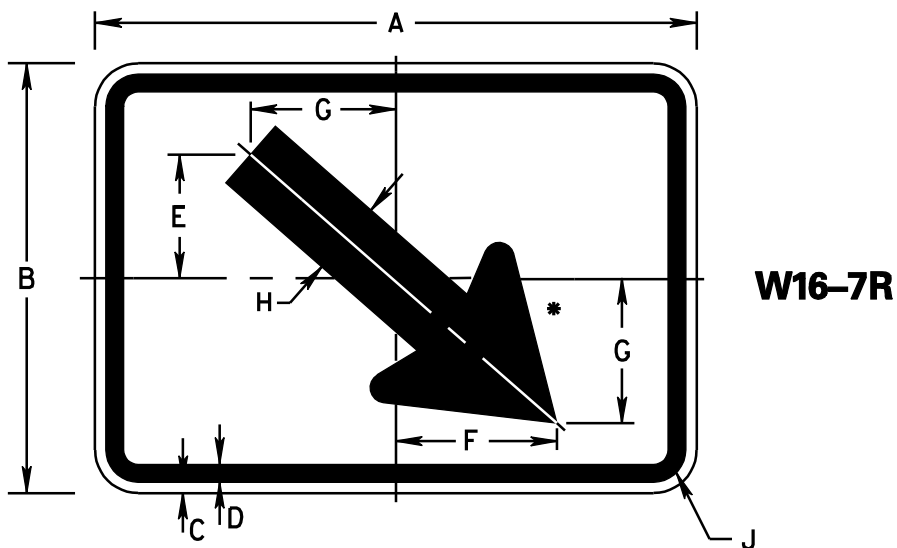

**W16-7L**

**COLORS**

LEGEND - BLACK (NON-REF)  
 BACKGROUND - YELLOW (REF)

**DIMENSIONS (INCHES)**

A	B	C	D	E	F	G	H	J
21	15	3/8	5/8	4 5/16	5 5/8	5 1/16	2 5/8	1 1/8
28	21	3/8	5/8	5 3/4	7 1/2	6 3/4	3 1/2	1 1/8

\* - SEE APPENDIX FOR ARROW DESIGN  
 WHEN USED IN CONSTRUCTION OR MAINTENANCE OPERATIONS  
 THE SIGN SHALL HAVE AN ORANGE REFLECTIVE BACKGROUND,  
 AND SHALL HAVE THE SUFFIX "M" ADDED TO THE FABRICATION NUMBER.

W16-7R CODE	W16-7L CODE
21"x15"	21"x15"
28"x21"	28"x21"
21"x15" M	21"x15" M
28"x21" M	28"x21" M

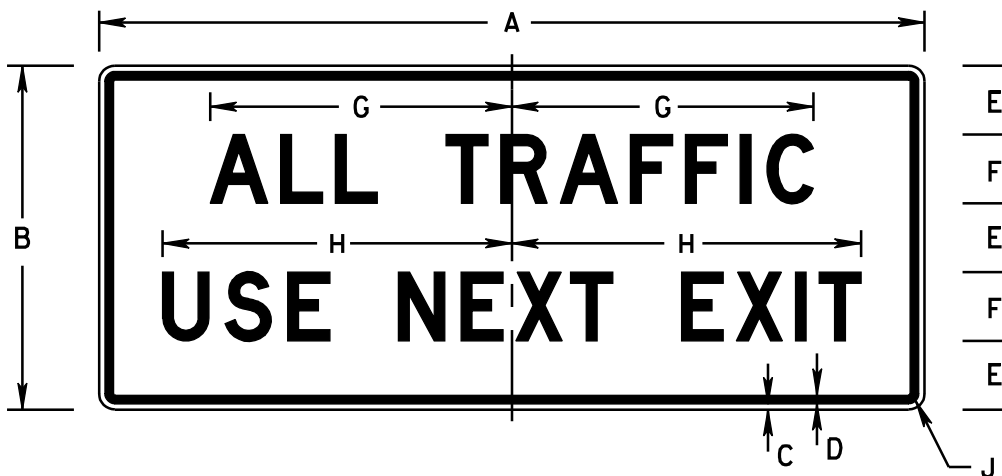

COLORS

LEGEND - BLACK (NON-REF)  
 BACKGROUND - YELLOW (REF)

DIMENSIONS (INCHES)

A	B	C	D	E	F	G	H	J
144	60	1	1 1/2	12	12D	52 1/4	60 13/16	2 3/4



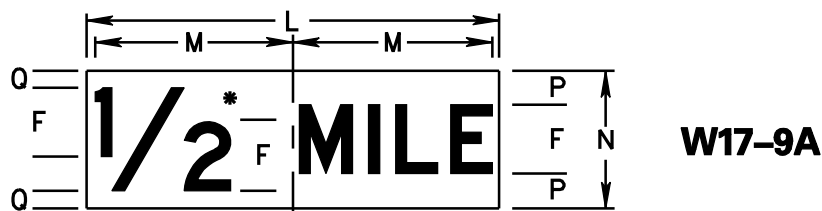
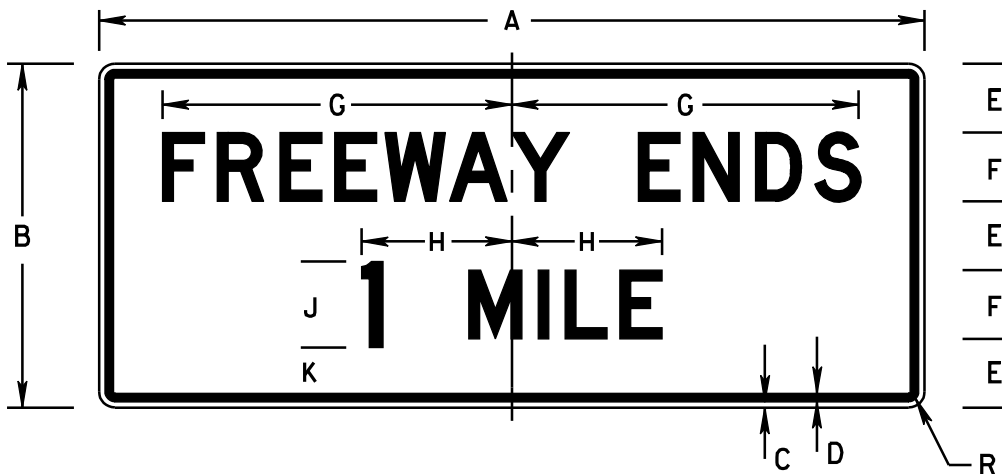

**W17-9A**

PLAQUE FOR USE WITH W17-9  
NO BORDER OR CORNER RADIUS

**COLORS**

LEGEND - BLACK (NON-REF)  
BACKGROUND - YELLOW (REF)

**DIMENSIONS (INCHES)**

A	B	C	D	E	F	G	H	J	K	L	M	N	P	Q	R
144	60	1	1 1/2	12	12D	60 13/16	25 9/16	15E	10 1/2	72	34 13/16	24	6	EQUAL	2 3/4

\* - SEE APPENDIX FOR FRACTION DETAILS

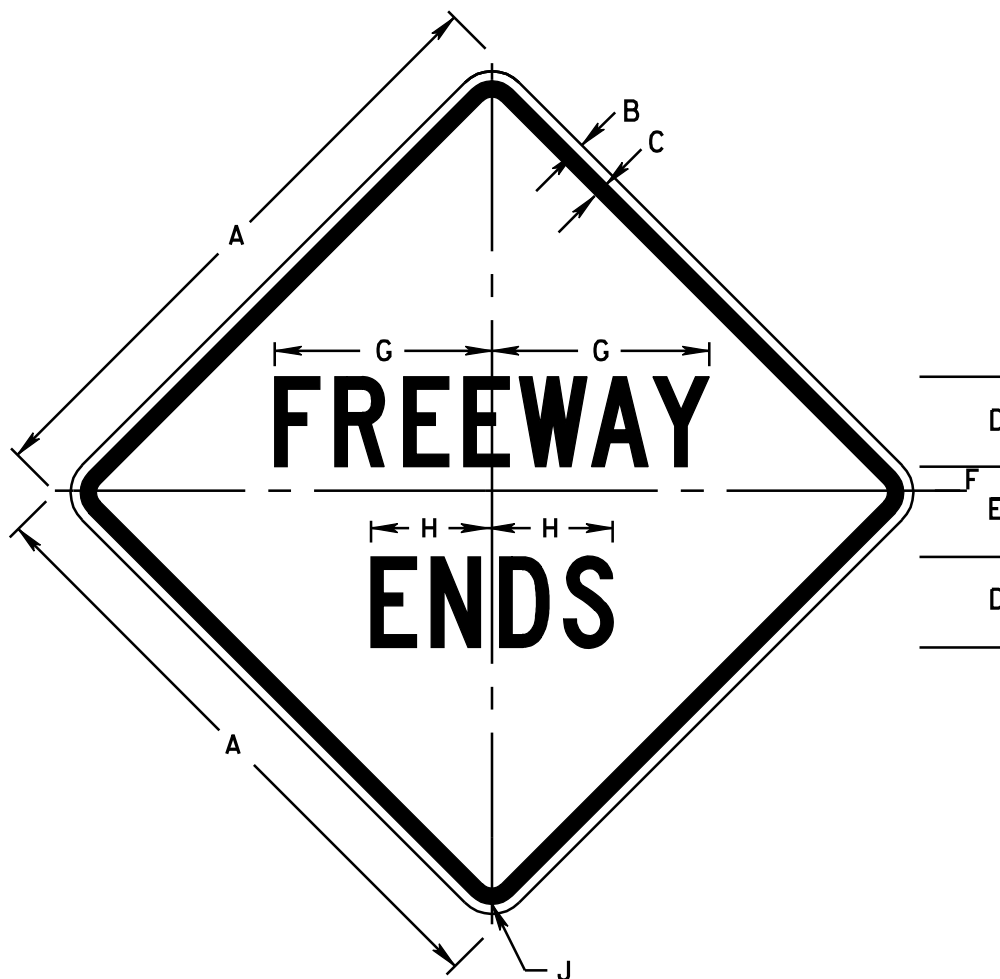

**COLORS**

LEGEND - BLACK (NON-REF)  
 BACKGROUND - YELLOW (REF)

**DIMENSIONS (INCHES)**

A	B	C	D	E	F	G	H	J
48	3/4	1 1/4	7C	7	2	16 7/8	9 7/16	2 1/4

PERMANENT CONDITION - USE YELLOW BACKGROUND  
 WORK ZONE - USE ORANGE BACKGROUND

WHEN USED IN CONSTRUCTION OR MAINTENANCE OPERATIONS  
 THE SIGN SHALL HAVE AN ORANGE REFLECTIVE BACKGROUND,  
 AND SHALL HAVE THE SUFFIX "M" ADDED TO THE FABRICATION NUMBER.

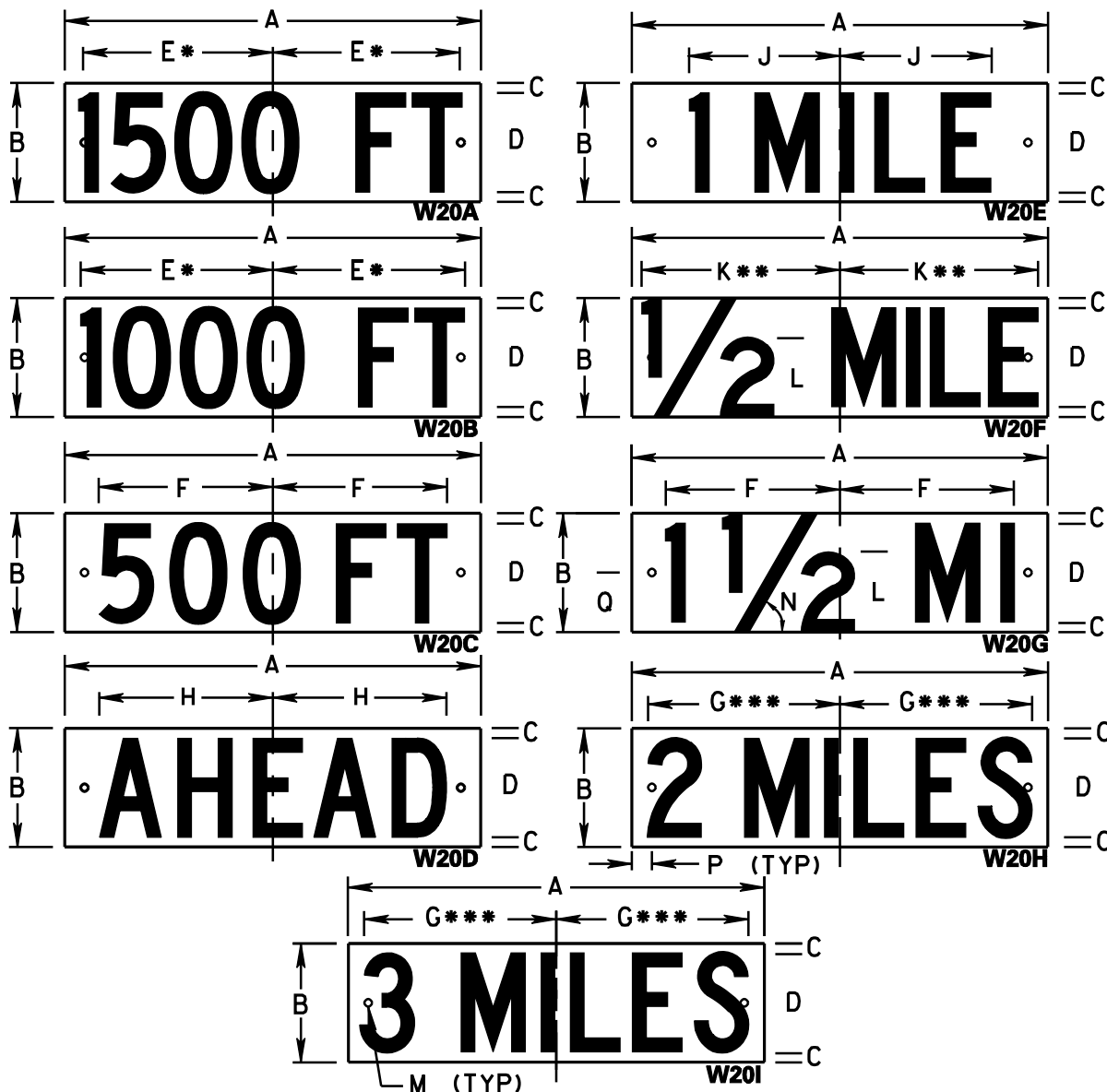

**COLORS**

LEGEND - BLACK (NON-REF)  
 BACKGROUND - ORANGE (REF)

**DIMENSIONS (INCHES)**

A	B	C	D	E	F	G	H	J	K	L	M	N	P	Q
21	6	1/2	5C	9 11/16	8 13/16	9 11/16	8 3/4	7 5/8	10	4D	3/8	60°	1	3
28	8	1/2	7C	13 5/16	12 1/8	13 3/4	12 1/4	10 5/8	13 3/4	5D	3/8	60°	1 1/2	4

**VISUALLY CENTER FRACTION BAR**

- \* - REDUCE SPACING 40%
- \*\* - REDUCE SPACING 50%
- \*\*\* - REDUCE SPACING 25%

21" x 6"		28" x 8"	
W20A	022001	W20A	022002
W20B		W20B	022008
W20C		W20C	022013
W20D		W20D	
W20E	022018	W20E	022019
W20F	022024	W20F	022025
W20G		W20G	
W20H		W20H	
W20I		W20I	

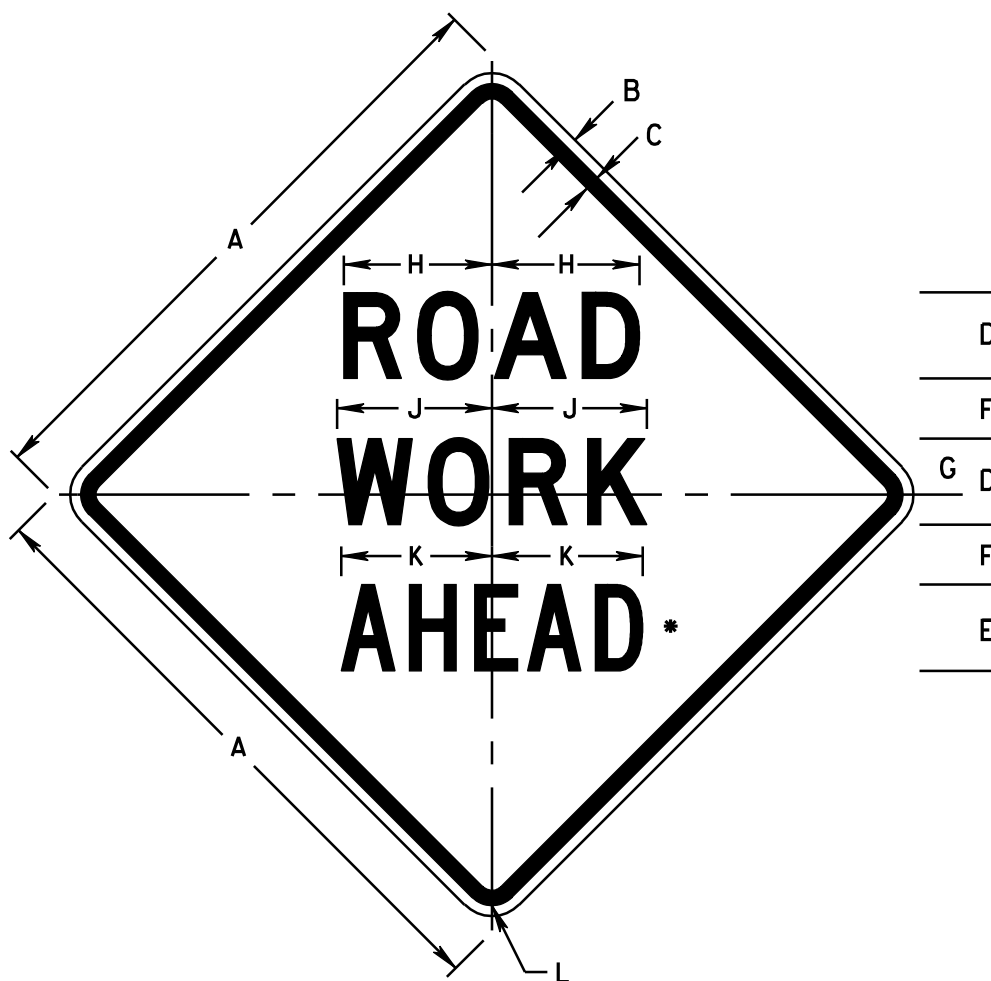

**COLORS**

LEGEND - BLACK (NON-REF)  
 BACKGROUND - ORANGE (REF)

**DIMENSIONS (INCHES)**

A	B	C	D	E	F	G	H	J	K	L	PLAQUE
36	5/8	7/8	5D	5C	3 1/2	3 1/4	8 5/8	9	8 3/4	1 5/8	21 X 6
48	3/4	1 1/4	7D	7C	4 3/4	4 1/2	12 1/16	12 5/8	12 1/4	2 1/4	28 X 8

\* - ALTERNATE LINE #3: 500 FT, 1000 FT, 1500 FT, 1/2 MILE, 1 MILE, 1 1/2 MI, 2 MILES, AND 3 MILES. ALTERNATE LINE #3 MAY BE DIRECT APPLIED COPY OR APPROPRIATE PLAQUE (SEE DETAIL SHEET W20).

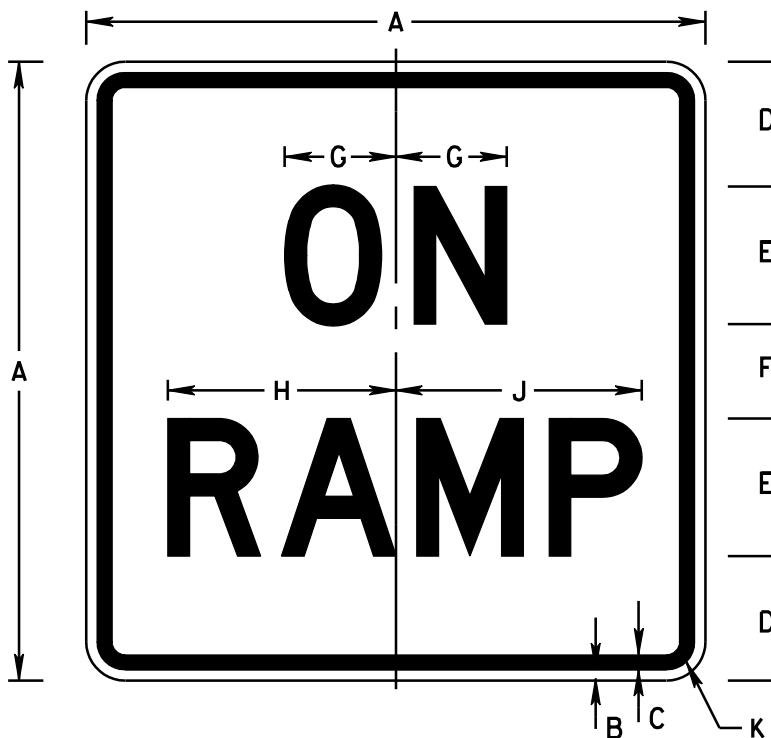

COLORS

LEGEND - BLACK (NON-REF)  
 BACKGROUND - ORANGE (REF)

DIMENSIONS (INCHES)

A	B	C	D	E	F	G	H	J	K
36	5/8	7/8	7 1/4	8D	5 1/2	6 7/16	13 1/4	14 3/8	1 5/8

TO BE USED IN CONJUNCTION WITH OTHER CONSTRUCTION SERIES SIGNS.

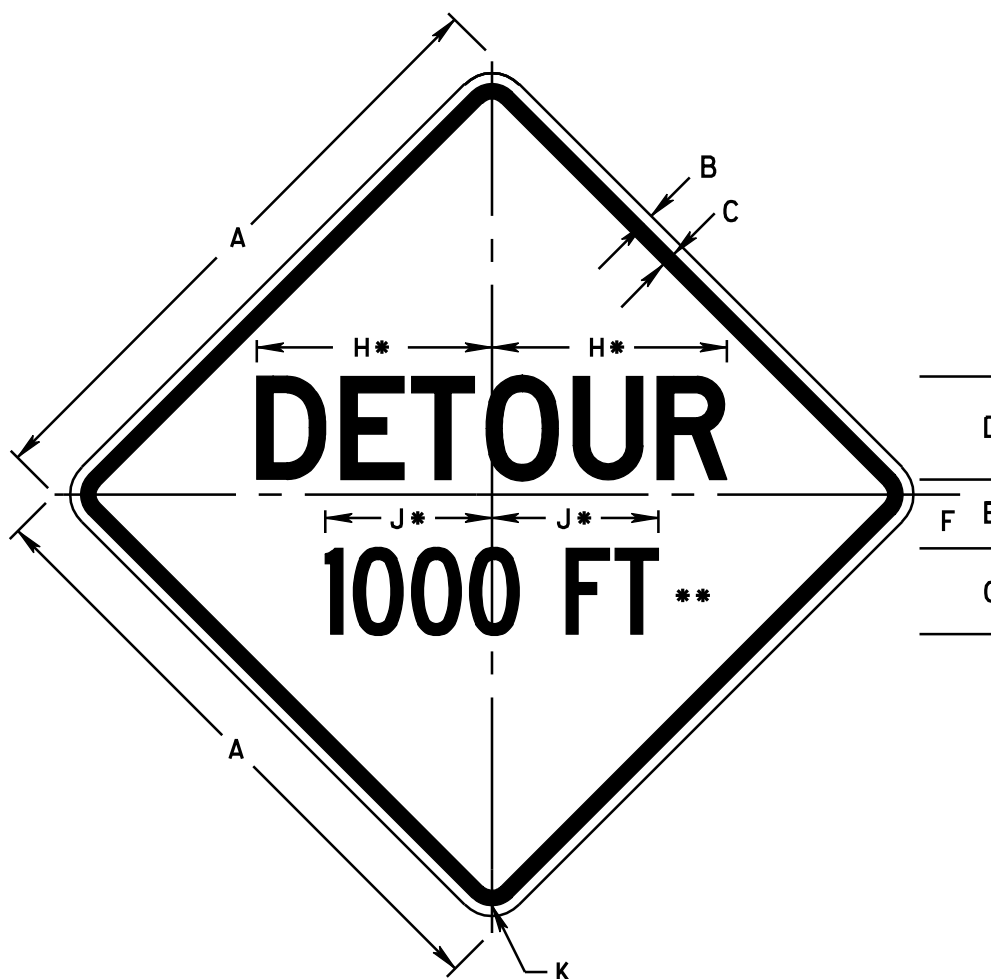

**COLORS**

LEGEND - BLACK (NON-REF)  
 BACKGROUND - ORANGE (REF)

**DIMENSIONS (INCHES)**

A	B	C	D	E	F	G	H	J	K	PLAQUE
36	5/8	7/8	6D	4	3 1/8	5C	13 1/16	9 1/16	1 5/8	21 X 6
48	3/4	1 1/4	8D	5 1/4	4	7C	18 1/4	13 5/16	2 1/4	28 X 8

\* - REDUCE SPACING 40%

\*\* - ALTERNATE LINE #2: 500 FT, 1500 FT, AHEAD, 1/2 MILE, 1 MILE, 1 1/2 MI, 2 MILES, AND 3 MILES. ALTERNATE LINE #2 MAY BE DIRECT APPLIED COPY OR APPROPRIATE PLAQUE (SEE DETAIL SHEET W20).

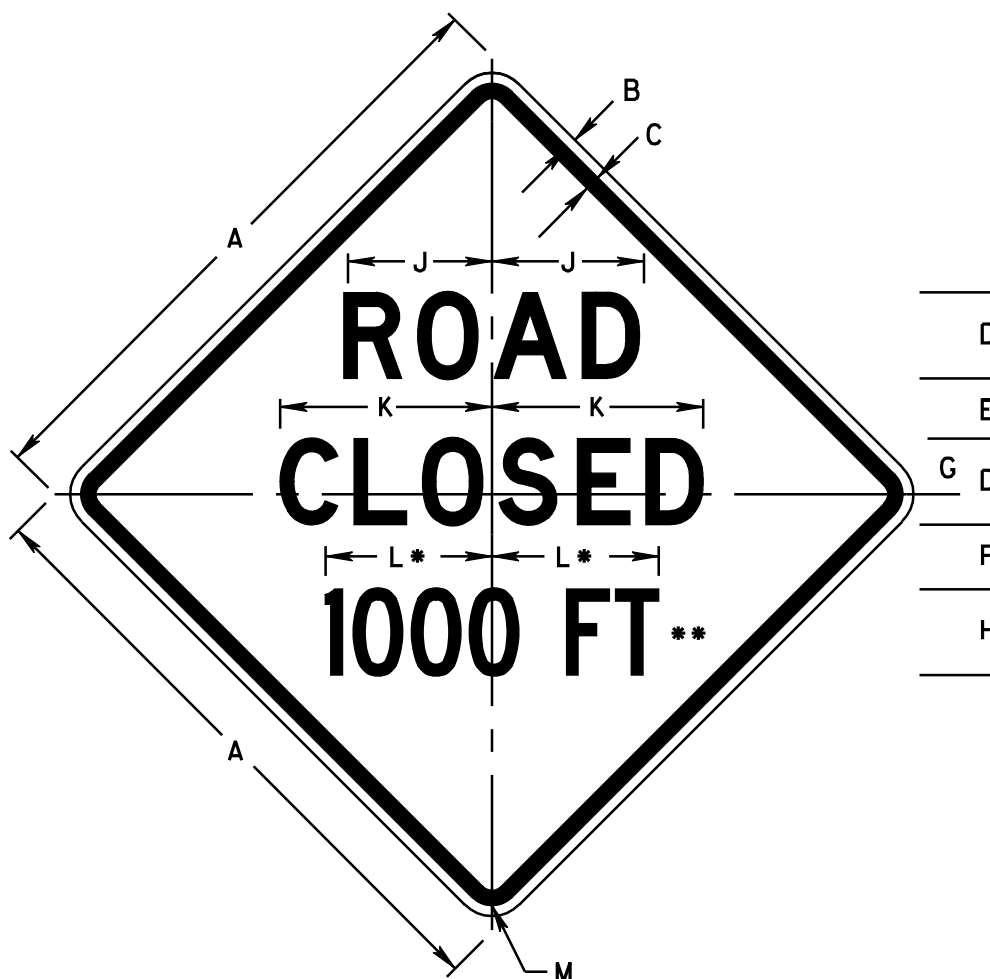

**COLORS**  
 LEGEND - BLACK (NON-REF)  
 BACKGROUND - ORANGE (REF)

**DIMENSIONS (INCHES)**

A	B	C	D	E	F	G	H	J	K	L	M	PLAQUE
36	5/8	7/8	5D	3 1/2	3 3/4	3 1/4	5C	8 5/8	12 5/16	9 11/16	1 5/8	21 X 6
48	3/4	1 1/4	7D	4 3/4	5 1/4	4 1/2	7C	12 1/16	17 1/4	13 5/16	2 1/4	28 X 8

\* - REDUCE SPACING 40%

\*\* - ALTERNATE LINE #3: 500 FT, 1500 FT, AHEAD, 1/2 MILE, 1 MILE, 1 1/2 MI, 2 MILES, AND 3 MILES. ALTERNATE LINE #3 MAY BE DIRECT APPLIED COPY OR APPROPRIATE PLAQUE (SEE DETAIL SHEET W20).

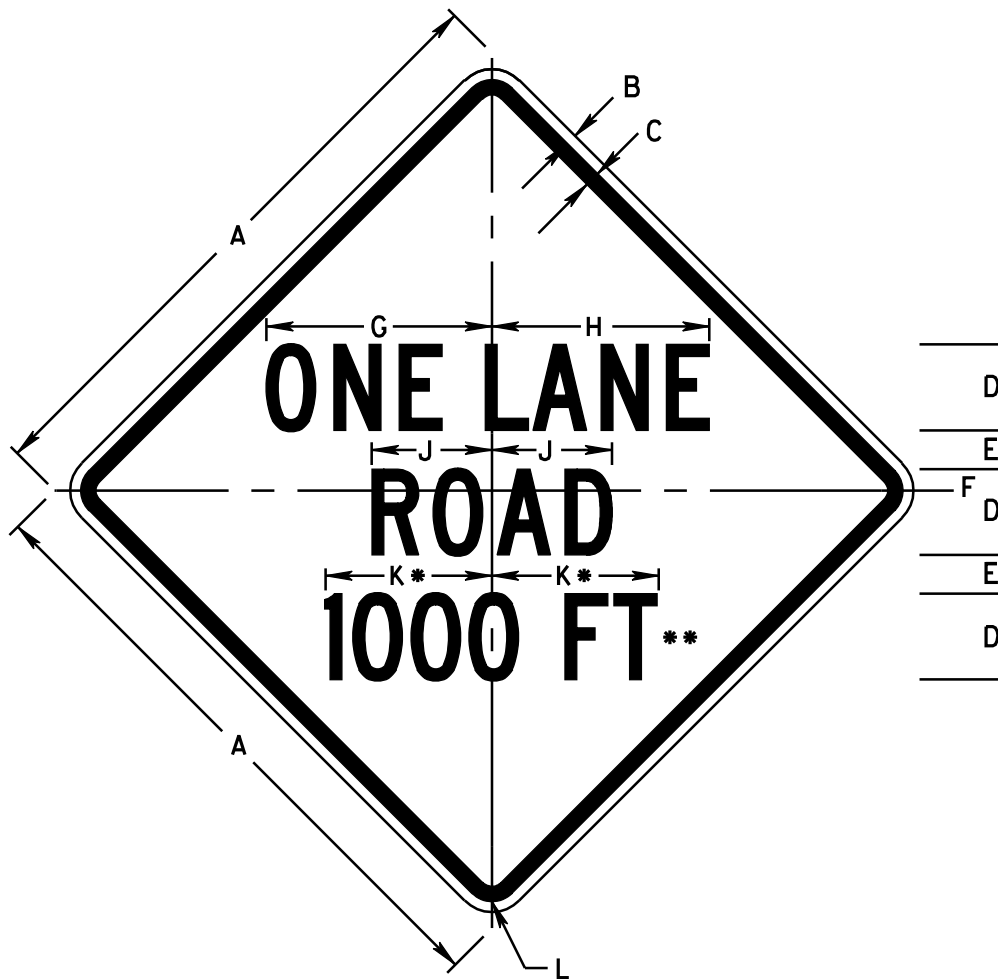

**COLORS**

LEGEND - BLACK (NON-REF)  
 BACKGROUND - ORANGE (REF)

**DIMENSIONS (INCHES)**

A	B	C	D	E	F	G	H	J	K	L	PLAQUE
36	5/8	7/8	5C	2 1/4	1 1/4	13 1/8	12 5/8	7	9 11/16	1 5/8	21 X 6
48	3/4	1 1/4	7C	3 1/8	1 3/4	18 1/2	17 3/4	9 11/16	13 5/16	2 1/4	28 X 8

\* - REDUCE SPACING 40%

\*\* - ALTERNATE LINE #3: 500 FT, 1500 FT, AHEAD, 1/2 MILE, 1 MILE, 1 1/2 MI, 2 MILES, AND 3 MILES. ALTERNATE LINE #3 MAY BE DIRECT APPLIED COPY OR APPROPRIATE PLAQUE (SEE DETAIL SHEET W20).



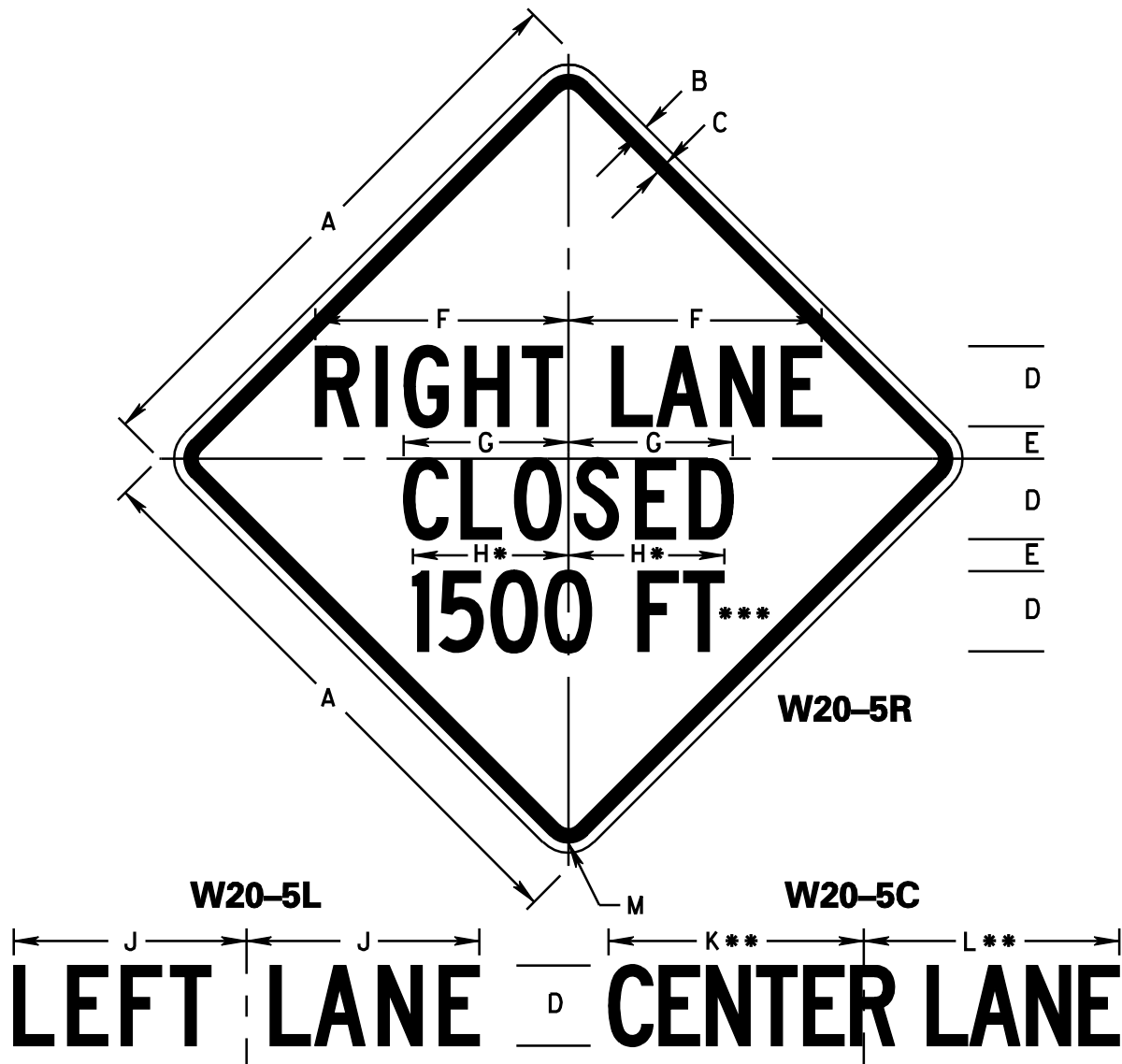

COLORS

LEGEND - BLACK (NON-REF)  
 BACKGROUND - ORANGE (REF)

DIMENSIONS (INCHES)

A	B	C	D	E	F	G	H	J	K	L	M	PLAQUE
36	5/8	7/8	5C	2	15 3/4	10 1/4	9 1/16	14 1/2	16 1/16	15 3/4	1 5/8	21 X 6
48	3/4	1 1/4	6C	3 1/2	19	12 5/16	11 5/8	17 7/16	20 3/8	19 3/8	2 1/4	28 X 8

\* - REDUCE SPACING 40%

\*\* - REDUCE SPACING 50%

\*\*\* - ALTERNATE LINE #3: 500 FT, 1000 FT, AHEAD, 1/2 MILE, 1 MILE, 1 1/2 MI, 2 MILES, AND 3 MILES. ALTERNATE LINE #3 MAY BE DIRECT APPLIED COPY OR APPROPRIATE PLAQUE (SEE DETAIL SHEET W20).

WV DEPARTMENT OF TRANSPORTATION  
 DIVISION OF HIGHWAYS  
 TRAFFIC ENGINEERING DIVISION

W20-5R CODE		W20-5L CODE	
36"		36"	
48"	022065	48"	022060
W20-5C CODE			
36"			
48"	022055		

**W20-5**

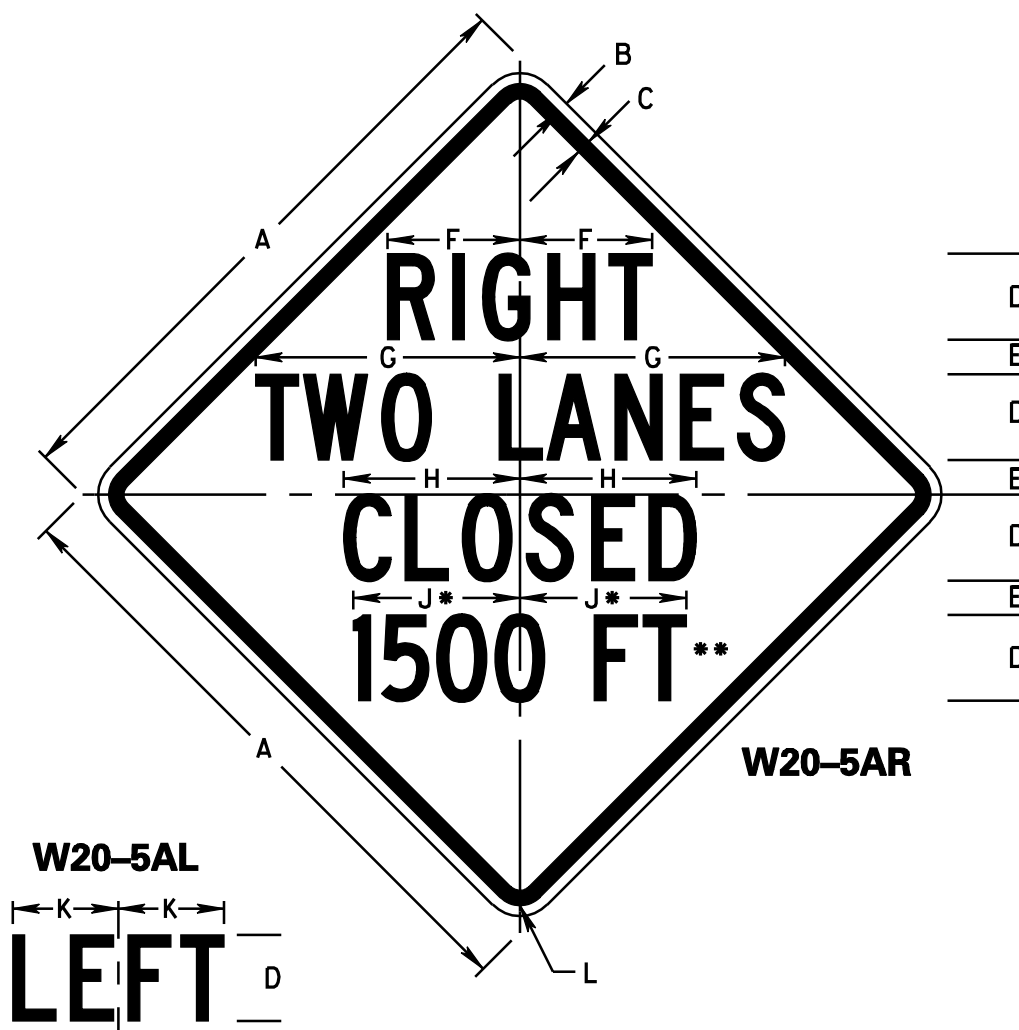

**COLORS**

LEGEND - BLACK (NON-REF)  
 BACKGROUND - ORANGE (REF)

**DIMENSIONS (INCHES)**

A	B	C	D	E	F	G	H	J	K	L	PLAQUE
36	5/8	7/8	5C	2	7 11/16	15 3/8	10 1/4	9 11/16	6 1/8	1 5/8	21 X 6
48	3/4	1 1/4	6C	3	9 1/4	19 1/8	12 5/16	11 5/8	7 3/8	2 1/4	28 X 8

\* - REDUCE SPACING 40%

\*\* - ALTERNATE LINE #4: 500 FT, 1000 FT, AHEAD, 1/2 MILE, 1 MILE, 1 1/2 MI, 2 MILES, AND 3 MILES. ALTERNATE LINE #4 MAY BE DIRECT APPLIED COPY OR APPROPRIATE PLAQUE (SEE DETAIL SHEET W20).

W20-5AR CODE		W20-5AL CODE	
36"		36"	
48"	022086	48"	022088

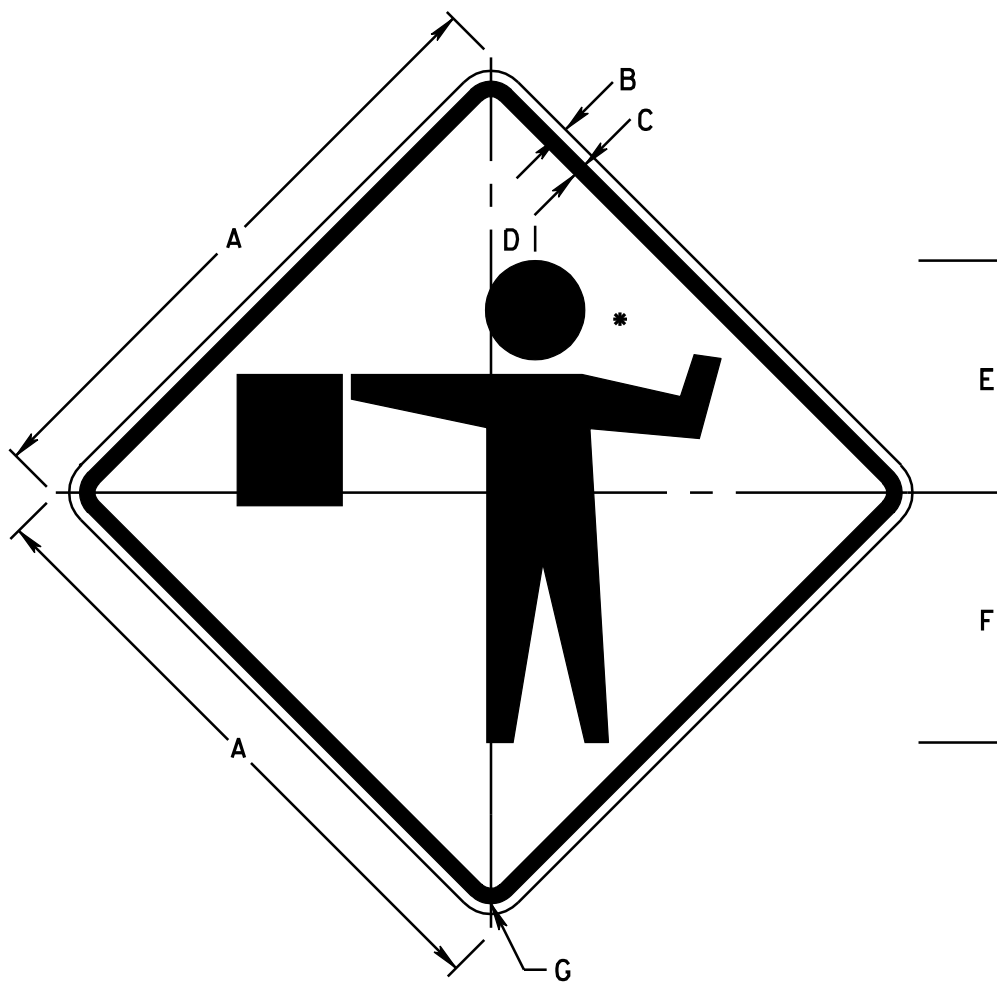

**COLORS**

LEGEND - BLACK (NON-REF)  
 BACKGROUND - ORANGE (REF)

**DIMENSIONS (INCHES)**

A	B	C	D	E	F	G
36	5/8	7/8	2 3/4	13 1/2	14 5/8	1 5/8
48	3/4	1 1/4	3 3/4	18	19 1/2	2 1/4

\* - SEE APPENDIX FOR SYMBOL DESIGN

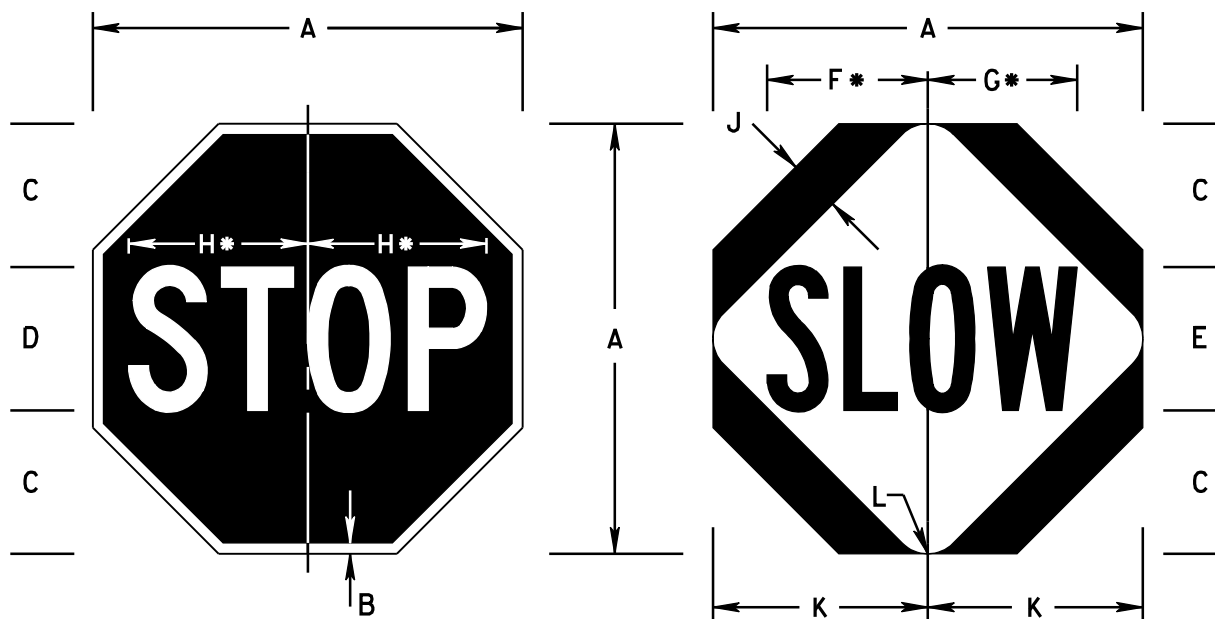

**COLORS**  
 LEGEND - WHITE (REF)  
 BACKGROUND - RED (REF)

**COLORS**  
 LEGEND - BLACK (NON-REF)  
 BACKGROUND - ORANGE (REF)  
 AREA OUTSIDE DIAMOND - BLACK

\* - REDUCE SPACING 40%

\* - REDUCE SPACING 40%

**DIMENSIONS (INCHES)**

A	B	C	D	E	F	G	H	J	K	L
18	1/2	6	6C	6B	6 3/4	6 1/4	7 1/2	2 3/16	9	1 1/2

**STOP - SLOW PADDLE**

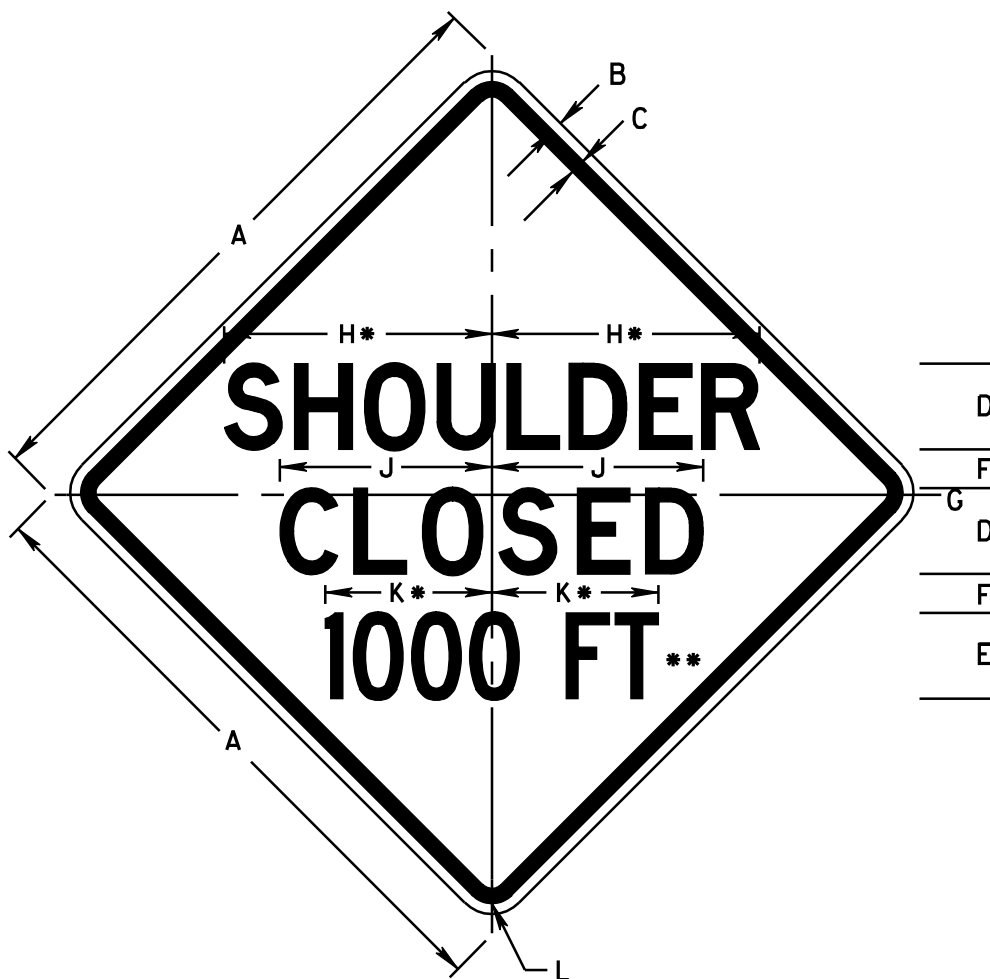

**COLORS**

LEGEND - BLACK (NON-REF)  
 BACKGROUND - ORANGE (REF)

**DIMENSIONS (INCHES)**

A	B	C	D	E	F	G	H	J	K	L	PLAQUE
36	5/8	7/8	5D	5C	2 1/4	1/4	15 9/16	12 5/16	9 11/16	1 5/8	21 X 6
48	3/4	1 1/4	6D	6C	3 3/4	1/2	18 11/16	14 3/4	11 5/8	2 1/4	28 X 8

\* - REDUCE SPACING 40%

\*\* - ALTERNATE LINE #3: 500 FT, 1500 FT, AHEAD, 1/2 MILE, 1 MILE, 1 1/2 MI, 2 MILES, AND 3 MILES. ALTERNATE LINE #3 MAY BE DIRECT APPLIED COPY OR APPROPRIATE PLAQUE (SEE DETAIL SHEET W20).

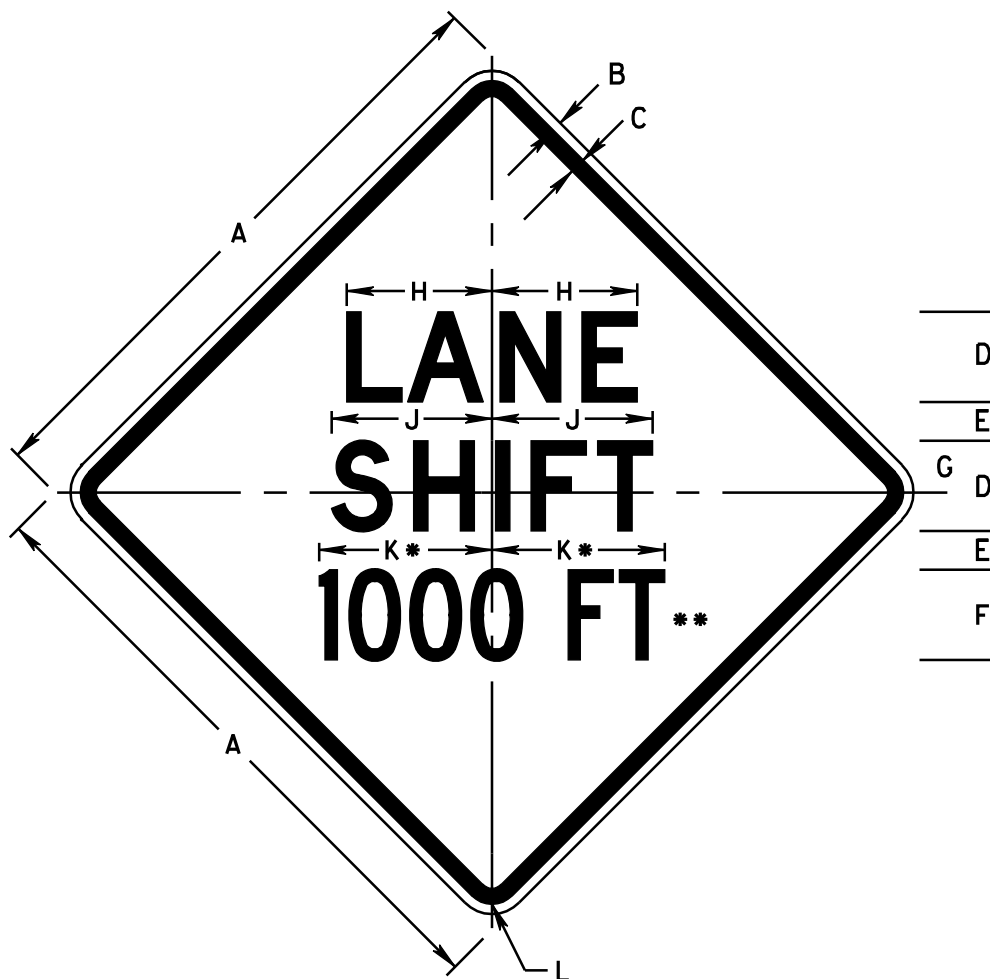

**COLORS**

LEGEND - BLACK (NON-REF)  
 BACKGROUND - ORANGE (REF)

**DIMENSIONS (INCHES)**

A	B	C	D	E	F	G	H	J	K	L	PLAQUE
36	5/8	7/8	5D	2 3/4	5C	3	8 1/16	8 7/8	9 11/16	1 5/8	21 X 6
48	3/4	1 1/4	7D	3	7C	4	11 1/4	12 7/16	13 5/16	2 1/4	28 X 8

\* - REDUCE SPACING 40%

\*\* - ALTERNATE LINE #3: 500 FT, 1500 FT, AHEAD, 1/2 MILE, 1 MILE, 1 1/2 MI, 2 MILES, AND 3 MILES. ALTERNATE LINE #3 MAY BE DIRECT APPLIED COPY OR APPROPRIATE PLAQUE (SEE DETAIL SHEET W20).

W20-11 CODE	
36"	
48"	

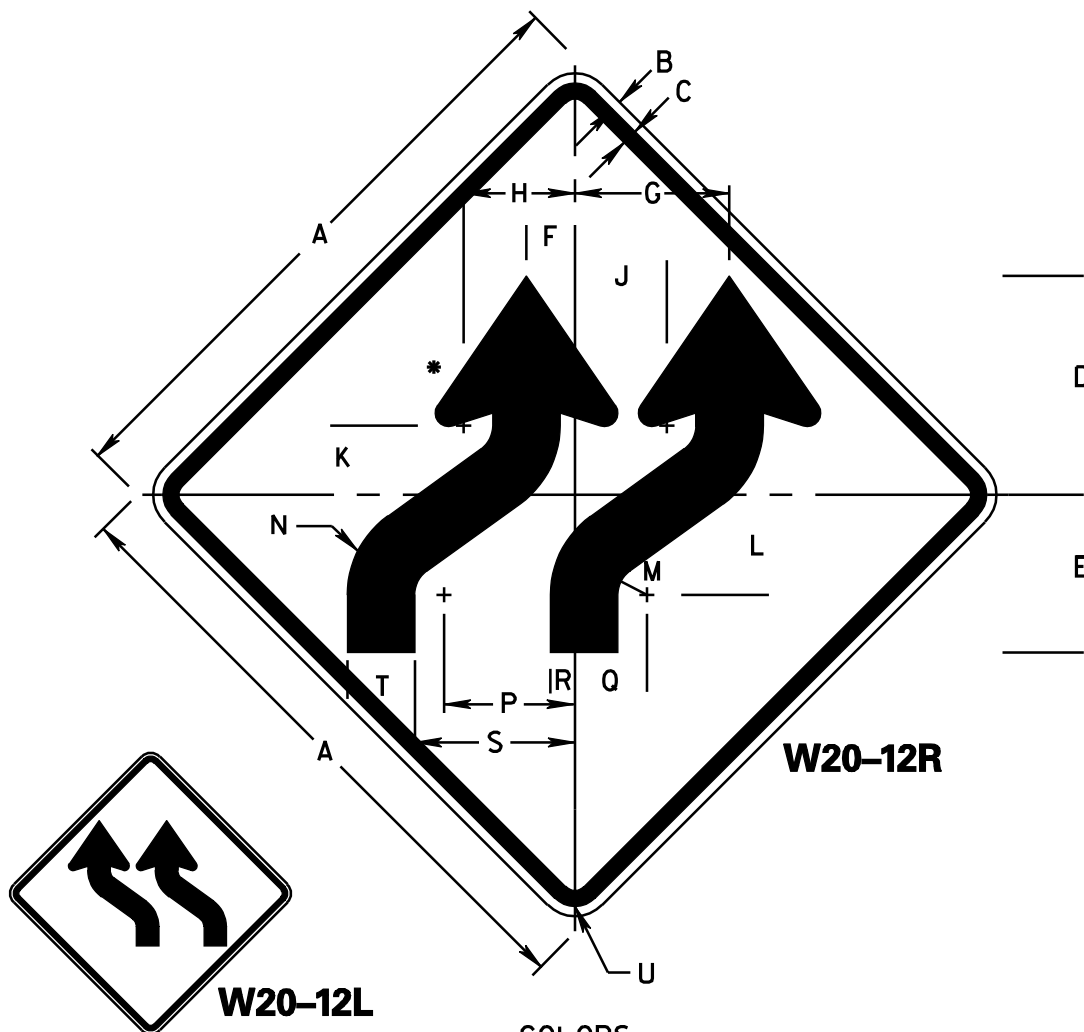

COLORS  
 LEGEND - BLACK (NON-REF)  
 BACKGROUND - ORANGE (REF)

DIMENSIONS (INCHES)

A	B	C	D	E	F	G	H	J	K	L	M	N	P
36	5/8	7/8	12 3/4	9 3/16	2 13/16	9	6 7/16	5 5/16	4	5 13/16	1 11/16	5 5/8	7 5/8
48	3/4	1 1/4	17	12 1/4	3 3/4	12	8 5/8	7 1/8	5 3/8	7 3/4	2 1/4	7 1/2	10 3/16

Q	R	S	T	U
4 3/16	1 7/16	9 5/16	3 15/16	1 5/8
5 9/16	1 15/16	12 7/16	5 1/4	2 1/4

\* - SEE APPENDIX FOR ARROW DESIGN

W20-12R CODE	W20-12L CODE
36"	36"
48"	48"

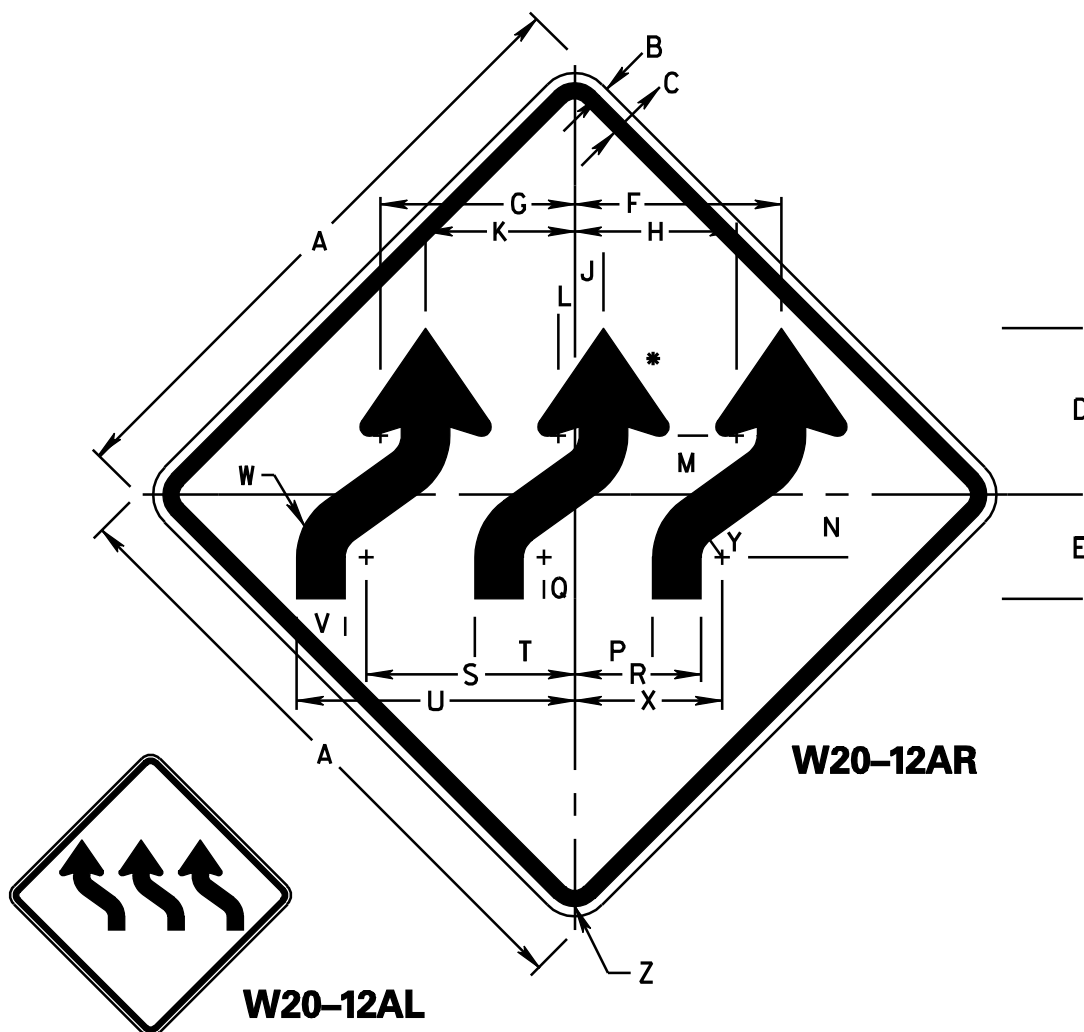

COLORS  
 LEGEND - BLACK (NON-REF)  
 BACKGROUND - ORANGE (REF)

DIMENSIONS (INCHES)

A	B	C	D	E	F	G	H	J	K	L	M	N	P
36	5/8	7/8	9 1/16	6 1/16	12	11 5/16	9 3/8	1 11/16	8 11/16	1 5/16	3 7/16	3 5/8	4 1/2
48	3/4	1 1/4	12 15/16	8 1/16	16	15 3/16	12 1/2	2 1/4	11 9/16	1 1/4	4 9/16	4 13/16	6 1/16

Q	R	S	T	U	V	W	X	Y	Z
1 13/16	7 3/8	12 1/8	5 13/16	16 3/16	2 13/16	4 1/16	8 9/16	1 3/16	1 5/8
2 3/8	9 13/16	16 3/16	7 3/4	21 9/16	3 3/4	5 3/8	11 7/16	1 5/8	2 1/4

\* - SEE APPENDIX FOR ARROW DESIGN

W20-12AR CODE	W20-12AL CODE
36"	36"
48"	48"



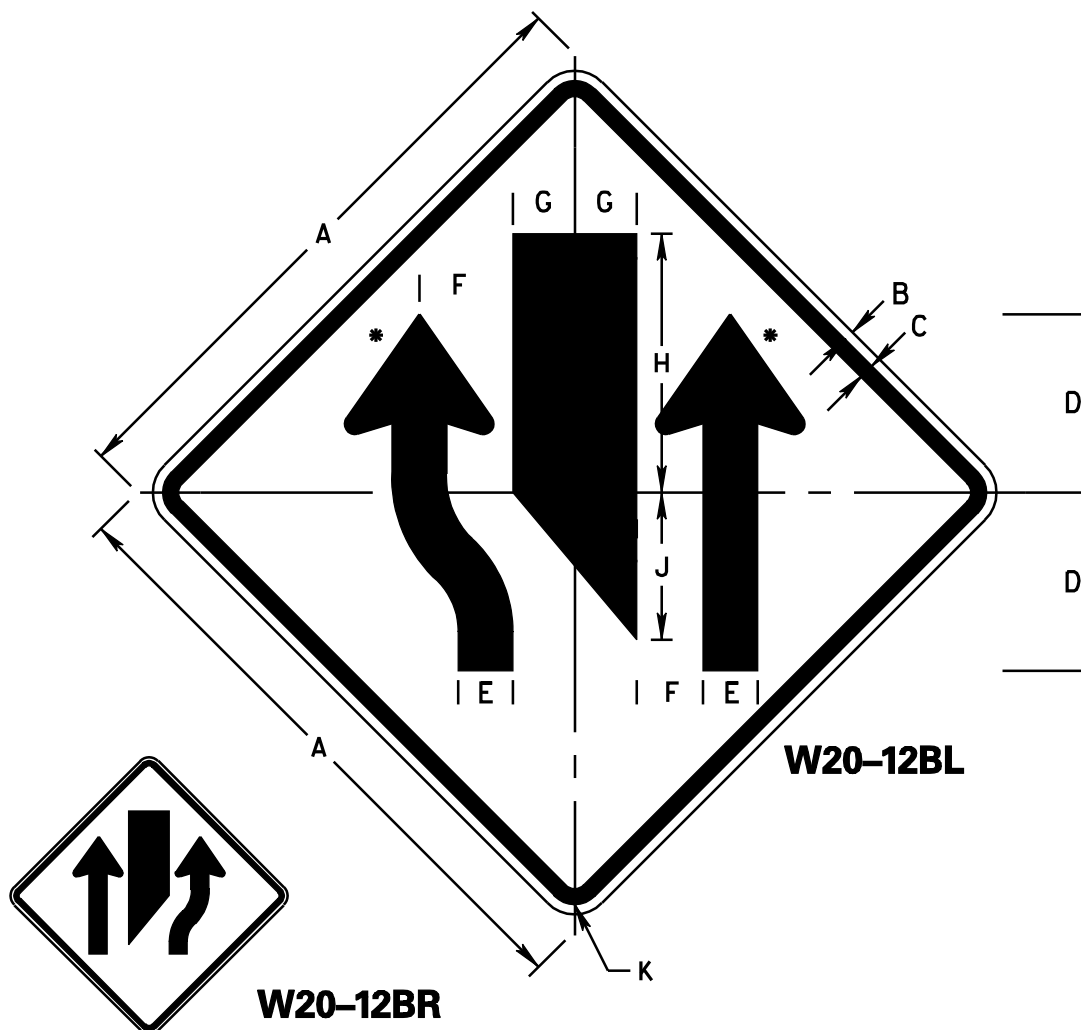

COLORS  
 LEGEND - BLACK (NON-REF)  
 BACKGROUND - ORANGE (REF)

DIMENSIONS (INCHES)

A	B	C	D	E	F	G	H	J	K
36	5/8	7/8	10 3/8	3 3/16	5 7/16	3 5/8	15 1/16	8 9/16	1 5/8
48	3/4	1 1/4	13 13/16	4 3/16	7 1/4	4 13/16	20 1/16	11 3/8	2 1/4

\* - SEE APPENDIX FOR ARROW DESIGN

W20-12BR CODE	W20-12BL CODE
36"	36"
48"	48"

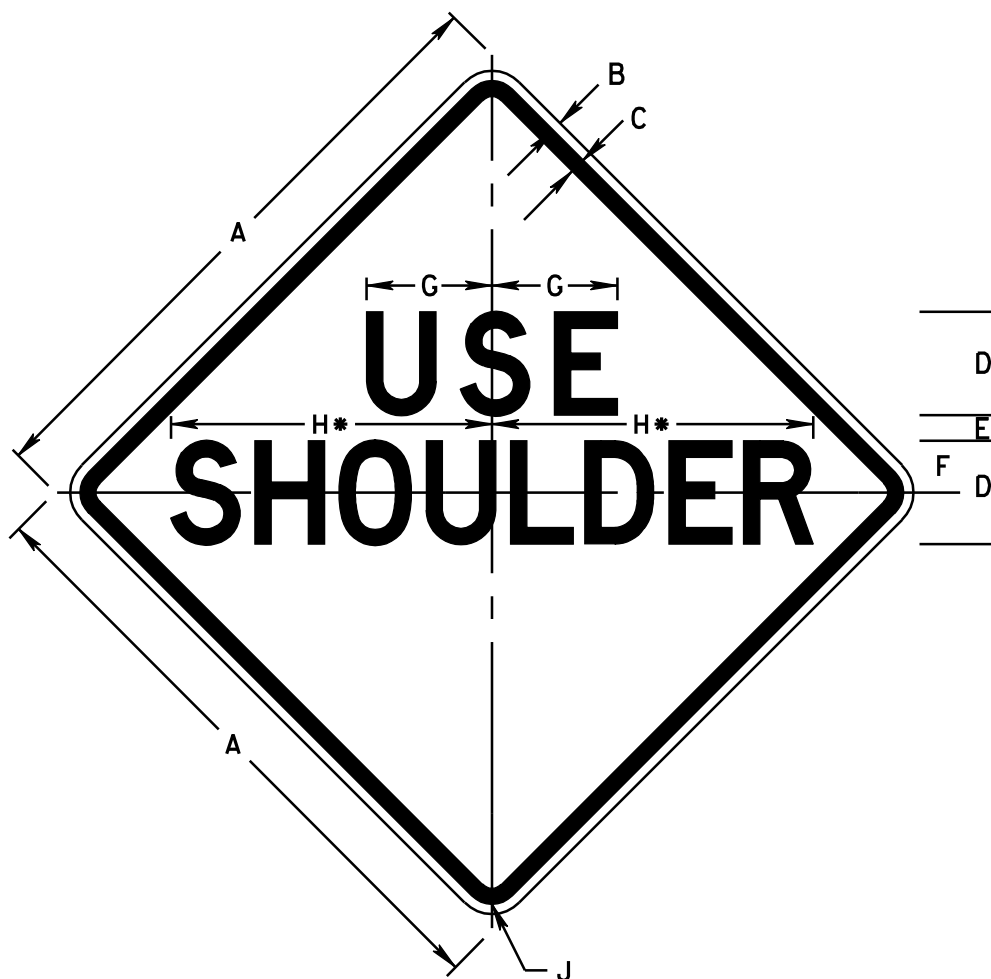

**COLORS**

LEGEND - BLACK (NON-REF)  
 BACKGROUND - ORANGE (REF)

**DIMENSIONS (INCHES)**

A	B	C	D	E	F	G	H	J
36	5/8	7/8	6D	2	3	7 5/16	18 11/16	1 5/8
48	3/4	1 1/4	8D	2	4	9 11/16	24 7/8	2 1/4

\* - REDUCE SPACING 40%

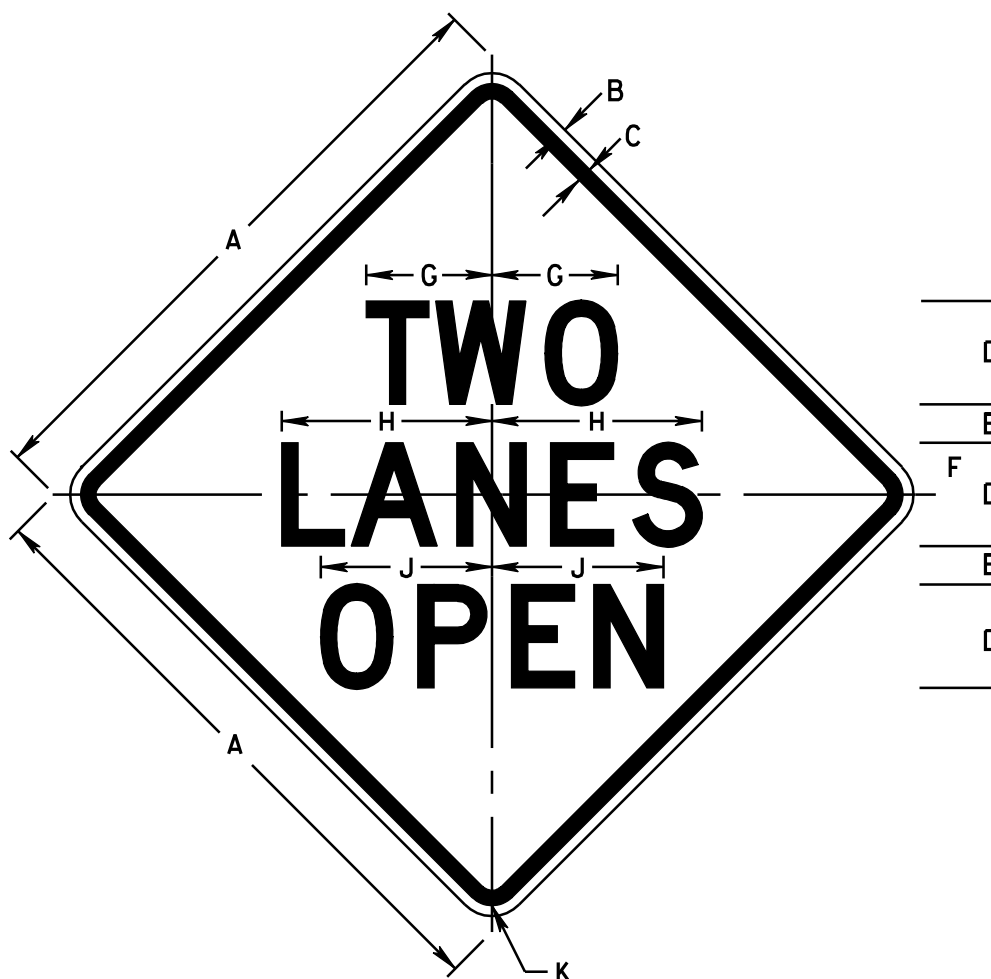

**COLORS**

LEGEND - BLACK (NON-REF)  
 BACKGROUND - ORANGE (REF)

**DIMENSIONS (INCHES)**

A	B	C	D	E	F	G	H	J	K
36	5/8	7/8	6D	2 1/4	3	7 5/16	12 1/4	9 15/16	1 5/8
48	3/4	1 1/4	8D	3	4	9 3/4	16 5/16	13 5/16	2 1/4

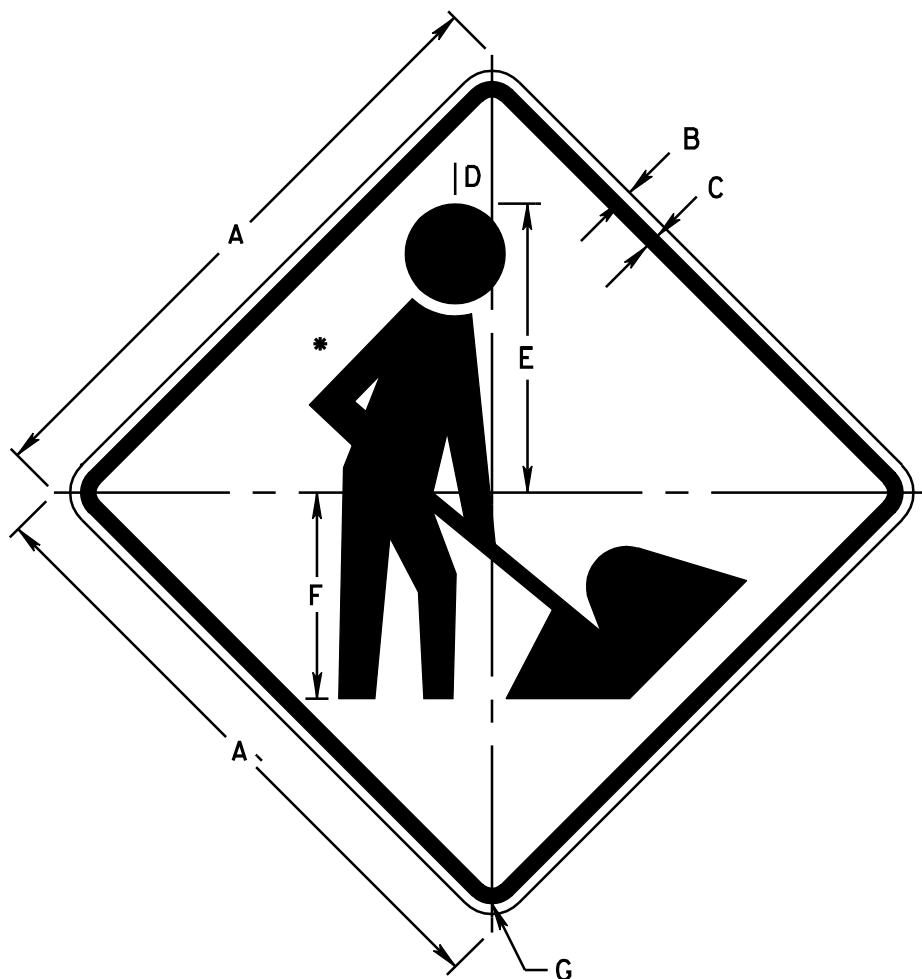

COLORS  
 LEGEND - BLACK (NON-REF)  
 BACKGROUND - ORANGE (REF)

DIMENSIONS (INCHES)

A	B	C	D	E	F	G
36	5/8	7/8	2 1/4	16 7/8	12	1 5/8
48	3/4	1 1/4	3	22 3/8	16	2 1/4

\* - SEE APPENDIX FOR SYMBOL DESIGN

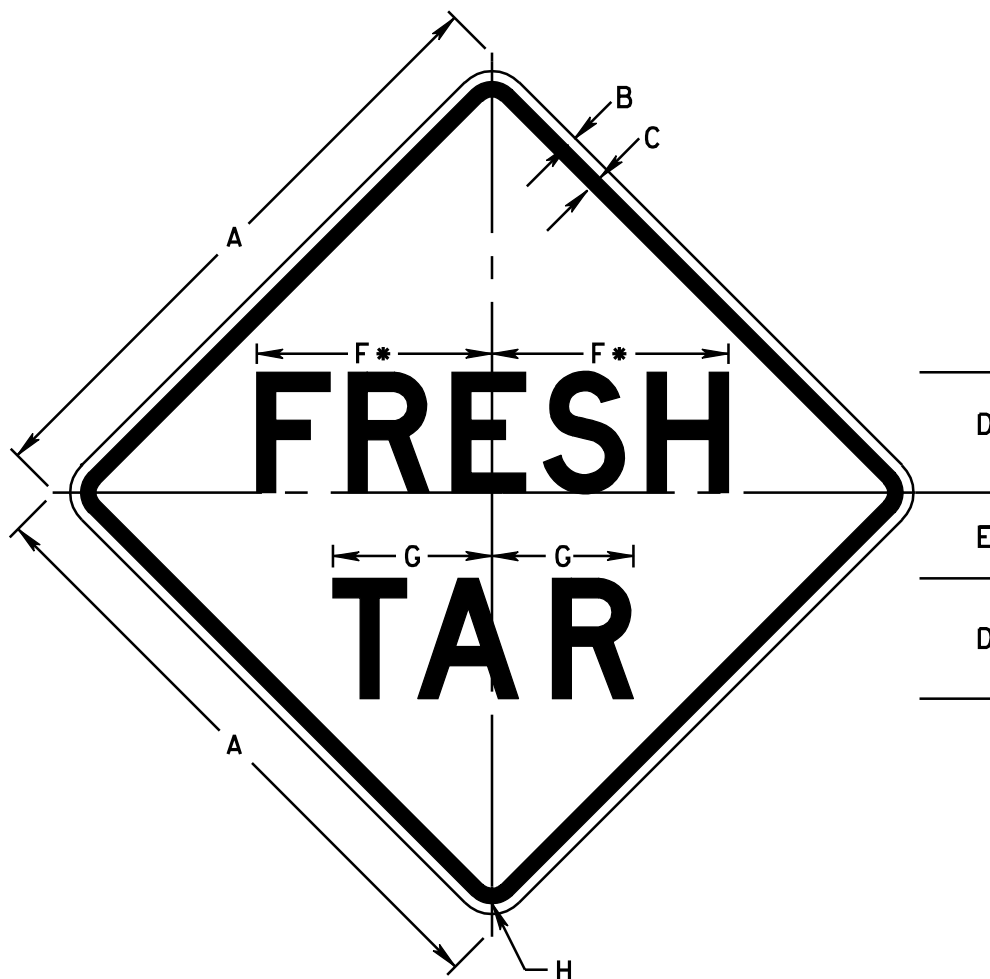

**COLORS**

LEGEND - BLACK (NON-REF)  
 BACKGROUND - ORANGE (REF)

**DIMENSIONS (INCHES)**

A	B	C	D	E	F	G	H
36	5/8	7/8	7D	5	13 11/16	7 5/8	1 5/8
48	3/4	1 1/4	9D	6	17 5/8	10 11/16	2 1/4

\* - REDUCE SPACING 20%

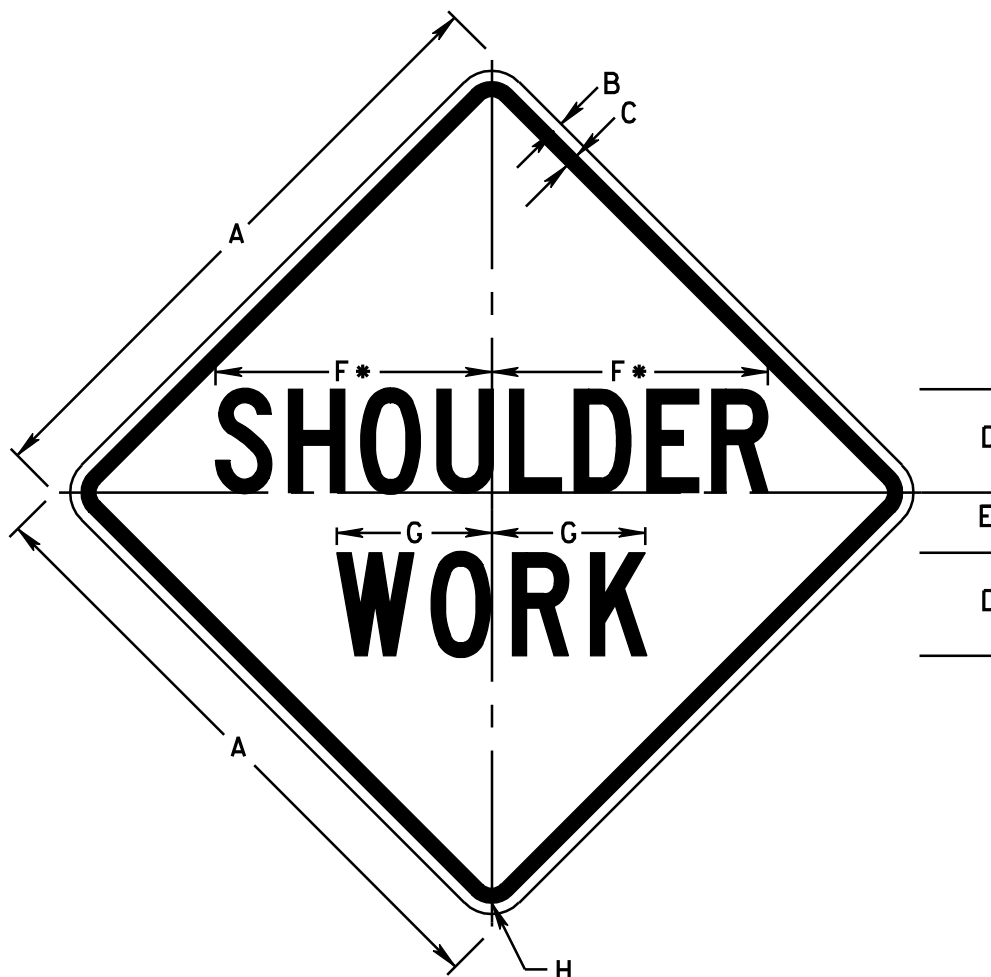

**COLORS**

LEGEND - BLACK (NON-REF)  
 BACKGROUND - ORANGE (REF)

**DIMENSIONS (INCHES)**

A	B	C	D	E	F	G	H
36	5/8	7/8	6C	3 1/2	16 1/16	9	1 5/8
48	3/4	1 1/4	8C	4	21 7/16	12	2 1/4

\* - REDUCE SPACING 25%

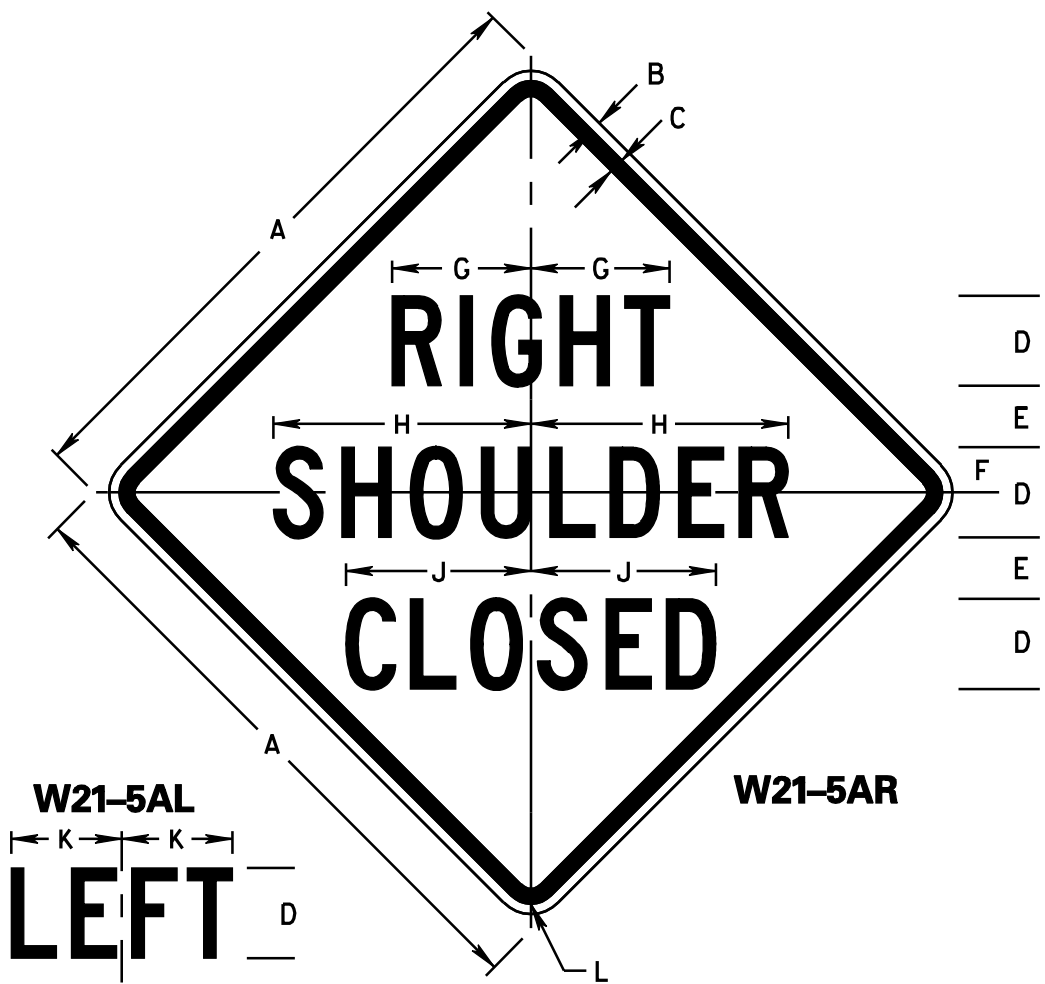

**COLORS**  
 LEGEND - BLACK (NON-REF)  
 BACKGROUND - ORANGE (REF)

**DIMENSIONS (INCHES)**

A	B	C	D	E	F	G	H	J	K	L
36	5/8	7/8	5C	3 5/8	2 1/2	7 11/16	14 1/4	10 1/4	6 1/8	1 5/8
48	3/4	1 1/4	7C	4 3/4	3 1/2	10 3/4	19 15/16	14 3/8	8 9/16	2 1/4

W21-5AR CODE	W21-5AL CODE
36"	36"
48"	48"

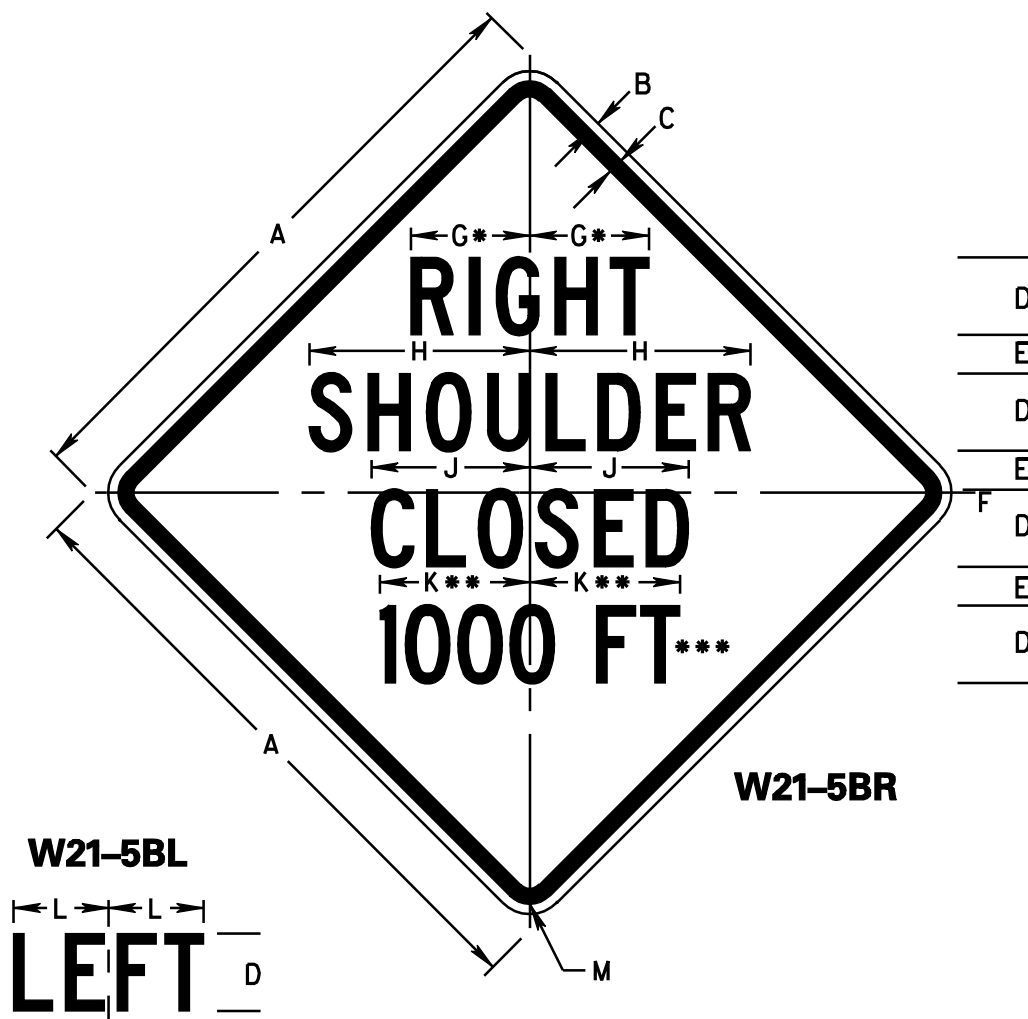

**COLORS**  
 LEGEND - BLACK (NON-REF)  
 BACKGROUND - ORANGE (REF)

**DIMENSIONS (INCHES)**

A	B	C	D	E	F	G	H	J	K	L	M	PLAQUE
36	5/8	7/8	5C	2 1/4	1/2	7 1/8	14 1/4	10 1/4	9 11/16	6 1/8	1 5/8	21 X 6
48	3/4	1 1/4	6C	3	1/4	9 1/4	17 1/8	12 5/16	11 5/8	7 3/8	2 1/4	28 X 8

\* - 36" REDUCE SPACING 30%

\*\* - REDUCE SPACING 40%

\*\*\* - ALTERNATE LINE #4: 500 FT, 1500 FT, AHEAD, 1/2 MILE, 1 MILE, 1 1/2 MI, 2 MILES, AND 3 MILES. ALTERNATE LINE #4 MAY BE DIRECT APPLIED COPY OR APPROPRIATE PLAQUE (SEE DETAIL SHEET W20).

W21-5BR CODE	W21-5BL CODE
36"	36"
48"	48"



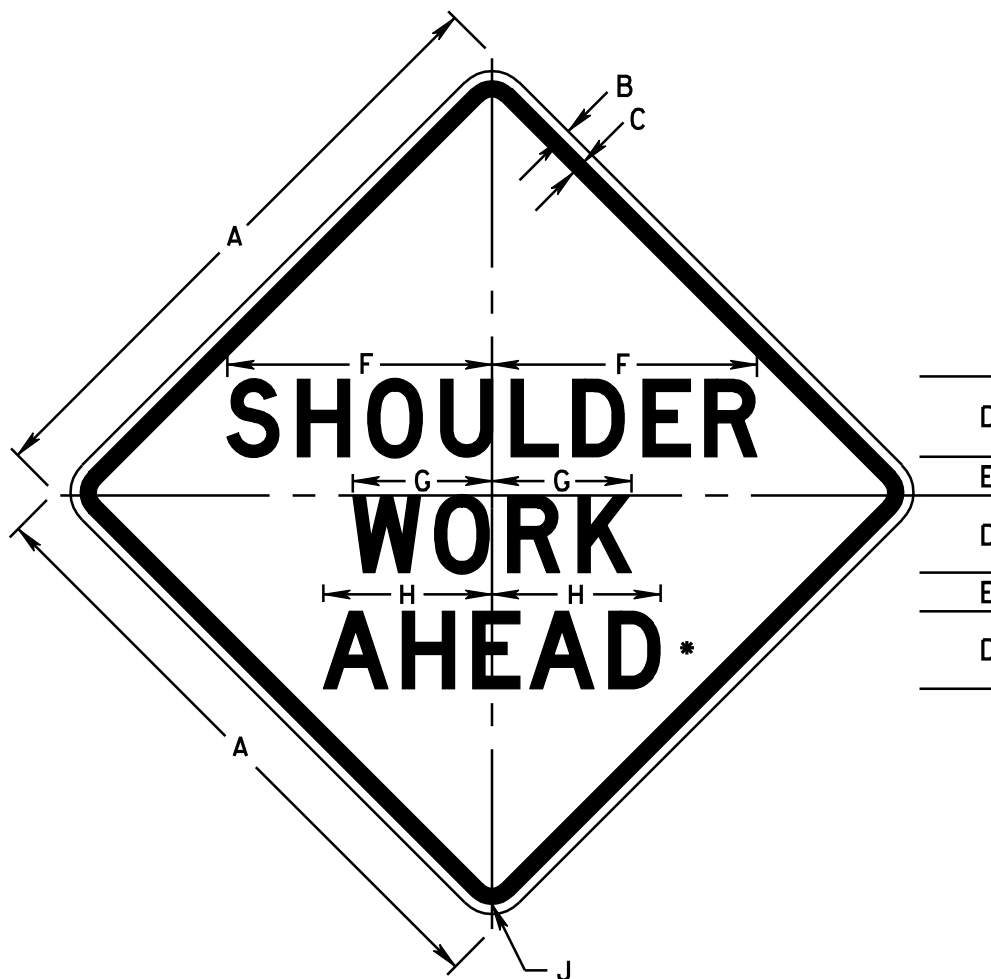

**COLORS**

LEGEND - BLACK (NON-REF)  
 BACKGROUND - ORANGE (REF)

**DIMENSIONS (INCHES)**

A	B	C	D	E	F	G	H	J	PLAQUE
36	5/8	7/8	4D	2 1/2	13 11/16	7 3/16	8 3/4	1 5/8	21 X 6
48	3/4	1 1/4	6D	3	20 9/16	10 13/16	13 1/16	2 1/4	28 X 8

\* - ALTERNATE LINE #3: 500 FT, 1000 FT, 1500 FT, 1/2 MILE, 1 MILE, 1 1/2 MI, 2 MILES, AND 3 MILES. ALTERNATE LINE #3 MAY BE DIRECT APPLIED COPY OR APPROPRIATE PLAQUE (SEE DETAIL SHEET W20).

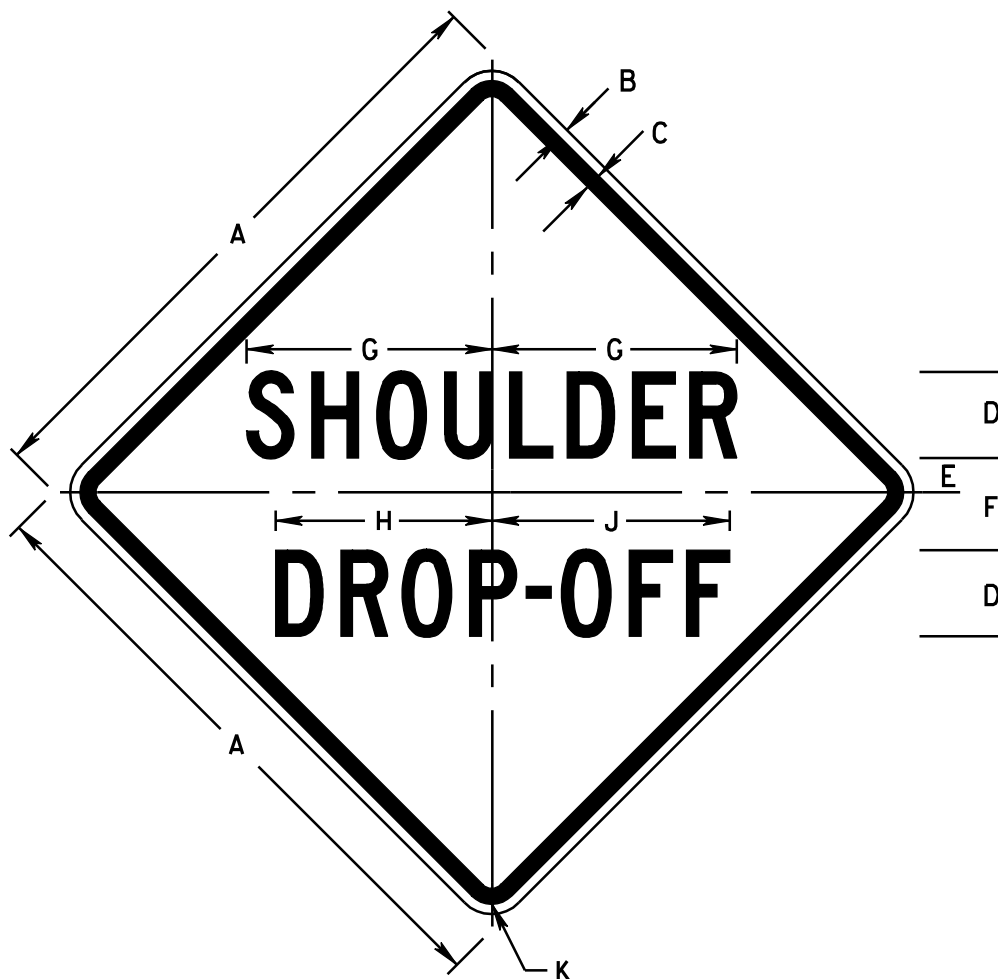

**COLORS**

LEGEND - BLACK (NON-REF)  
 BACKGROUND - ORANGE (REF)

**DIMENSIONS (INCHES)**

A	B	C	D	E	F	G	H	J	K
36	5/8	7/8	5C	2	5 3/8	14 1/4	12 9/16	13 13/16	1 5/8
48	3/4	1 1/4	7C	3 3/4	5 3/4	20	17 3/8	19 9/16	2 1/4

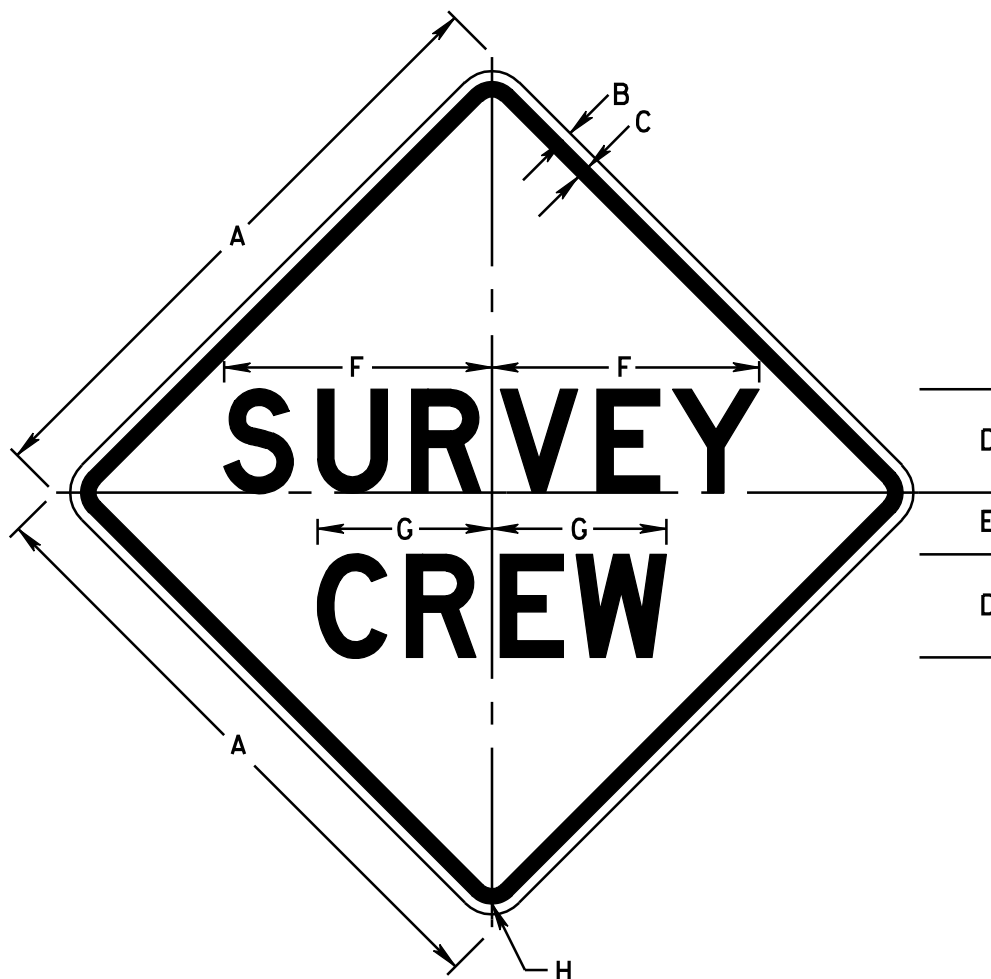

**COLORS**

LEGEND - BLACK (NON-REF)  
 BACKGROUND - ORANGE (REF)

**DIMENSIONS (INCHES)**

A	B	C	D	E	F	G	H
36	5/8	7/8	6D	3 1/2	15 9/16	10 1/8	1 5/8
48	3/4	1 1/4	8D	4	20 9/16	13 1/2	2 1/4

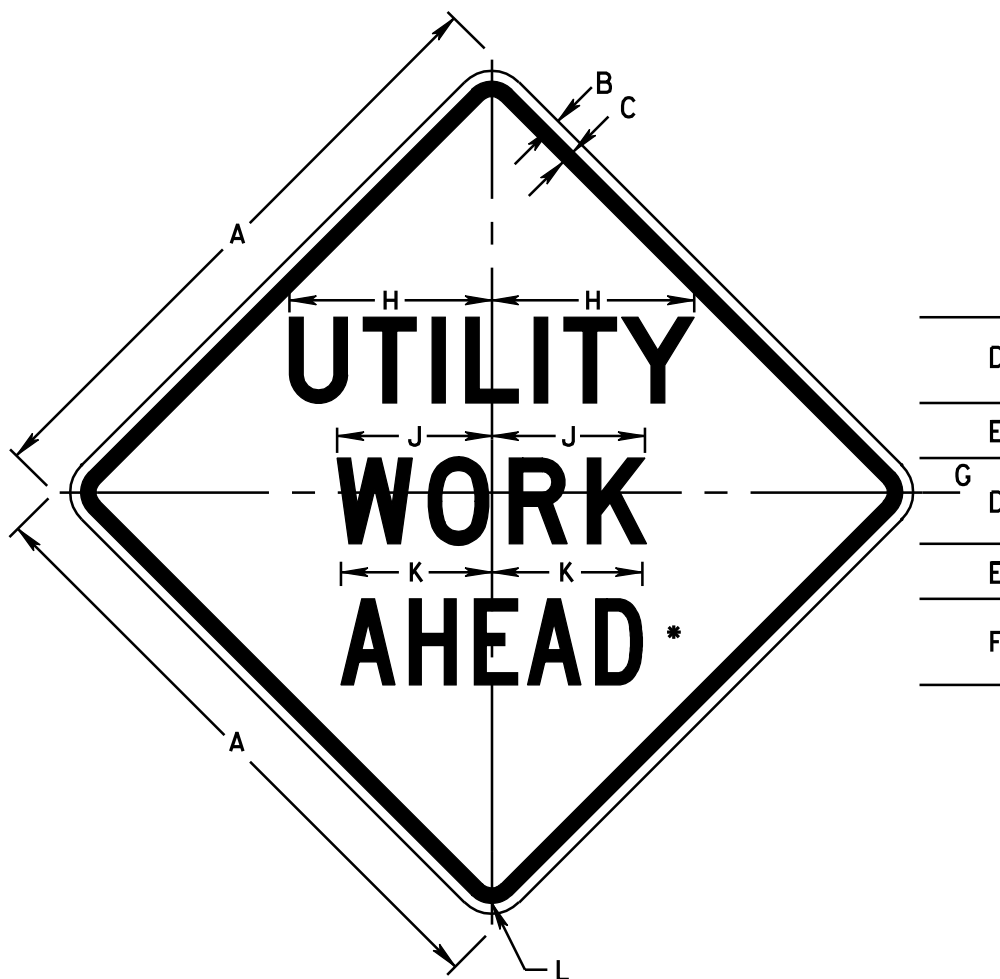

**COLORS**

LEGEND - BLACK (NON-REF)  
 BACKGROUND - ORANGE (REF)

**DIMENSIONS (INCHES)**

A	B	C	D	E	F	G	H	J	K	L	PLAQUE
36	5/8	7/8	5D	3 3/16	5C	2	1 1 3/4	9	8 3/4	1 5/8	21 X 6
48	3/4	1 1/4	7D	3 5/8	7C	2 5/16	16 1/2	12 5/8	12 1/4	2 1/4	28 X 8

\* - ALTERNATE LINE #3: 500 FT, 1000 FT, 1500 FT, 1/2 MILE, 1 MILE, 1 1/2 MI, 2 MILES, AND 3 MILES. ALTERNATE LINE #3 MAY BE DIRECT APPLIED COPY OR APPROPRIATE PLAQUE (SEE DETAIL SHEET W20).

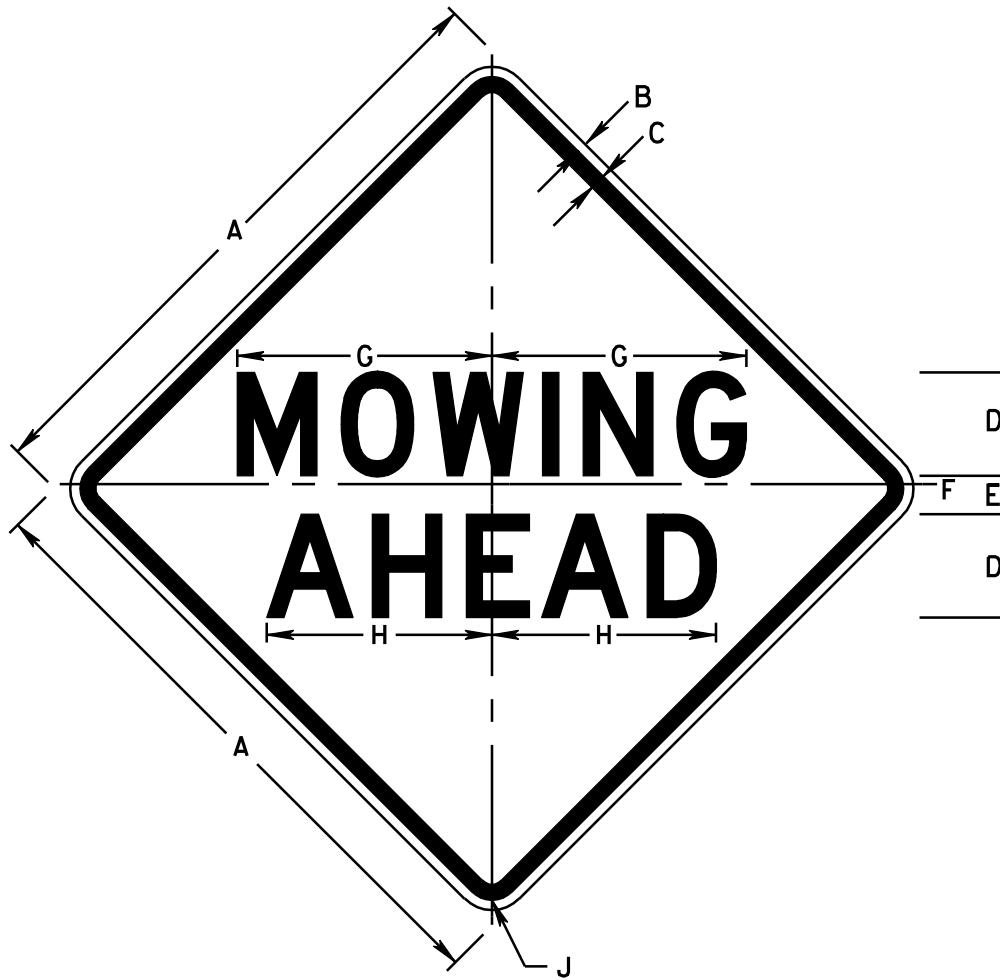

**COLORS**

LEGEND - BLACK (NON-REF)  
 BACKGROUND - ORANGE (REF)

**DIMENSIONS (INCHES)**

A	B	C	D	E	F	G	H	J
36	5/8	7/8	6D	2 3/16	1 1/16	14 3/4	13 1/8	1 5/8
48	3/4	1 1/4	8D	3	1	19 3/4	17 7/16	2 1/4

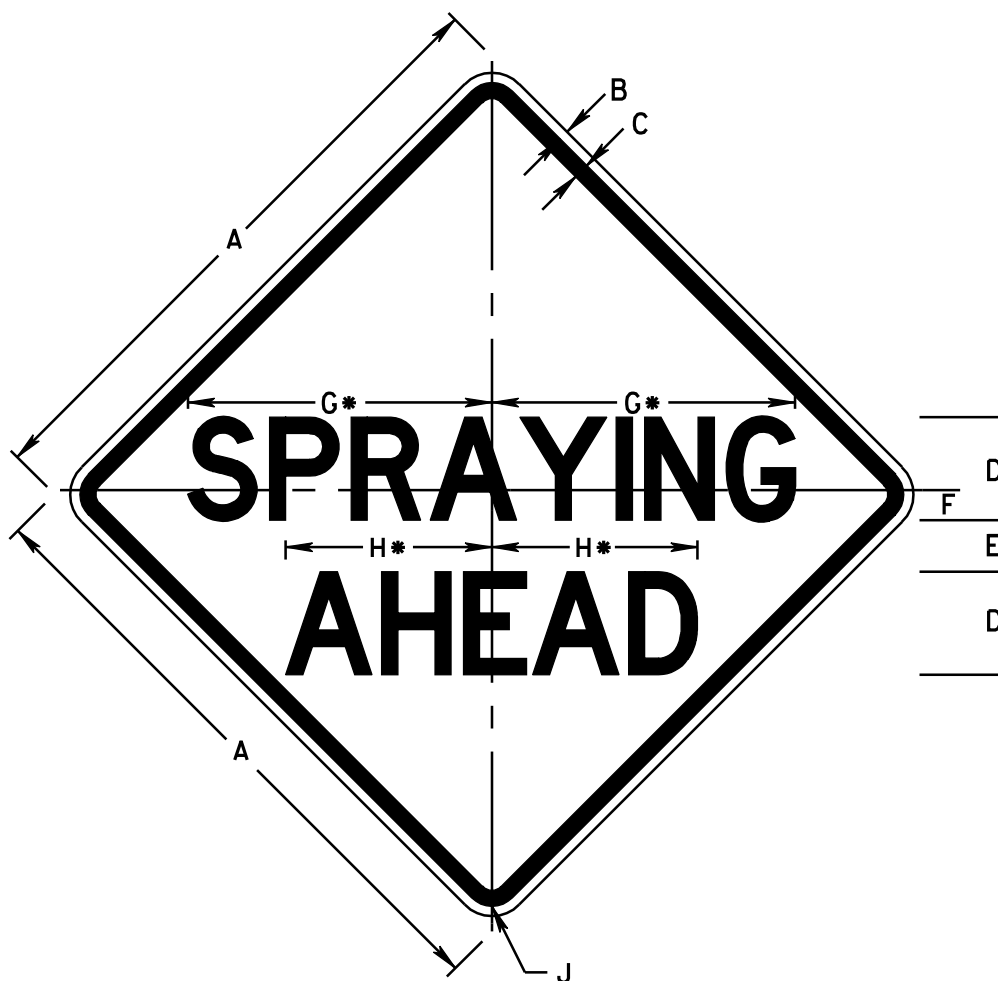

**COLORS**

LEGEND - BLACK (NON-REF)  
 BACKGROUND - ORANGE (REF)

**DIMENSIONS (INCHES)**

A	B	C	D	E	F	G	H	J
36	5/8	7/8	6D	2	2	17 11/16	12	1 5/8
48	3/4	1 1/4	8D	4	2	23 9/16	16	2 1/4

\* - REDUCE SPACING 50%

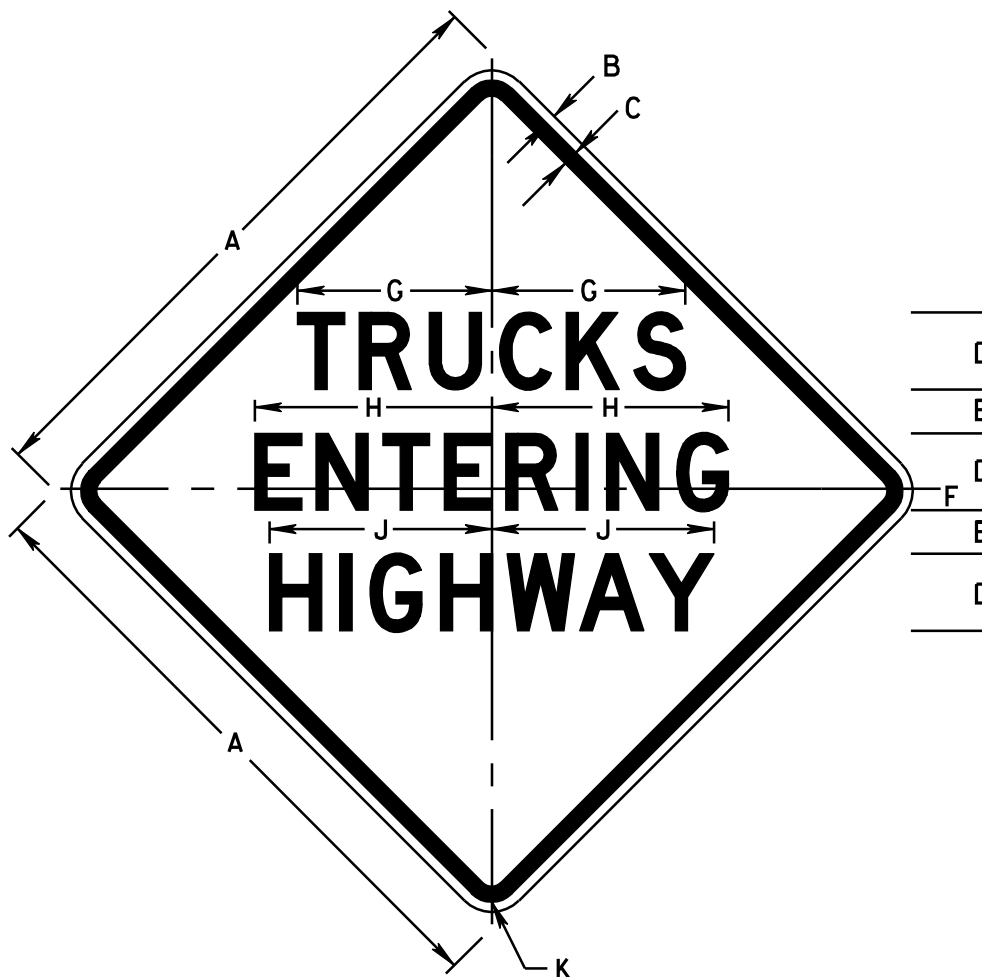

**COLORS**

LEGEND - BLACK (NON-REF)  
 BACKGROUND - ORANGE (REF)

**DIMENSIONS (INCHES)**

A	B	C	D	E	F	G	H	J	K
36	5/8	7/8	4D	2 3/4	3/4	10 1/16	12 1/4	11 1/2	1 5/8
48	3/4	1 1/4	6D	3 3/8	1 1/2	15 3/16	18 7/16	17 1/4	2 1/4

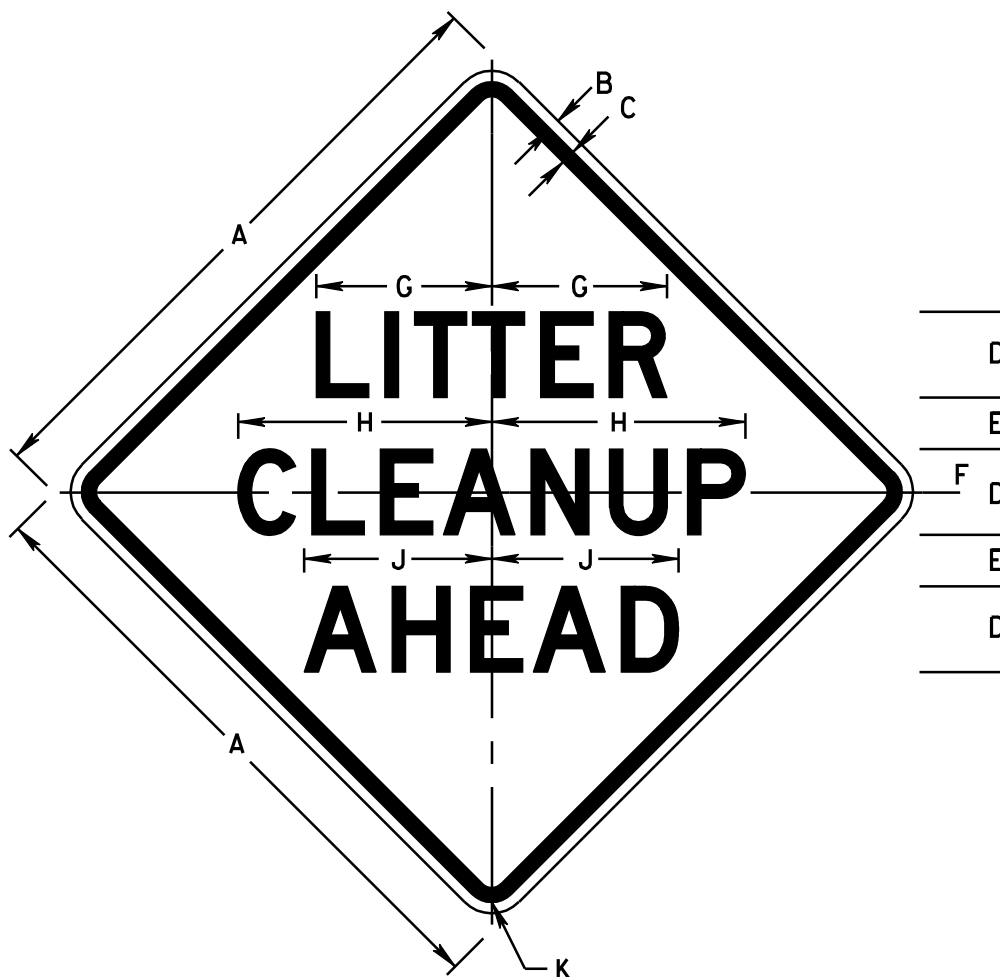

**COLORS**

LEGEND - BLACK (NON-REF)  
 BACKGROUND - ORANGE (REF)

**DIMENSIONS (INCHES)**

A	B	C	D	E	F	G	H	J	K
36	5/8	7/8	5D	3	2 1/2	10 3/16	14 3/4	10 5/16	1 5/8

FABRIC ONLY



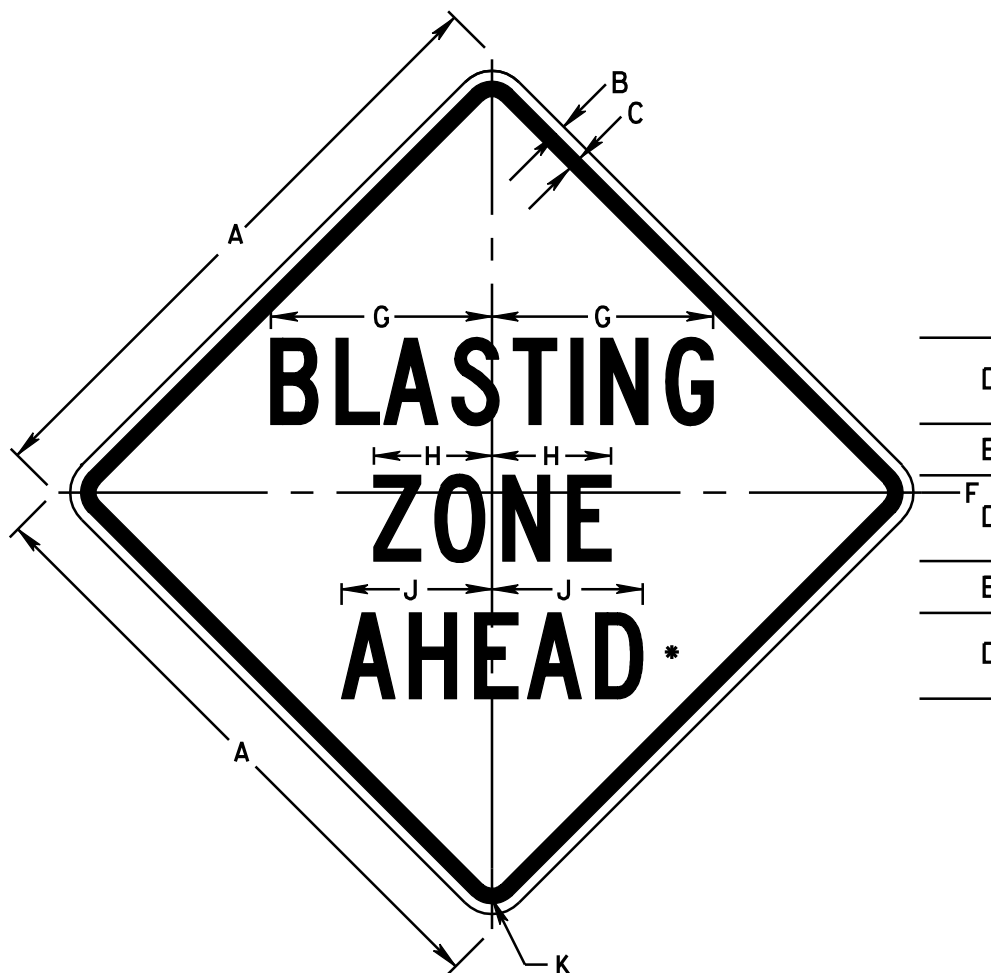

**COLORS**

LEGEND - BLACK (NON-REF)  
 BACKGROUND - ORANGE (REF)

**DIMENSIONS (INCHES)**

A	B	C	D	E	F	G	H	J	K	PLAQUE
36	5/8	7/8	5C	3	1	12 7/8	6 7/8	8 3/4	1 5/8	21 X 6
48	3/4	1 1/4	7C	3 1/2	1 3/4	18	9 11/16	12 1/4	2 1/4	28 X 8

\* - ALTERNATE LINE #3: 500 FT, 1000 FT, 1500 FT, 1/2 MILE, 1 MILE, 1 1/2 MI, 2 MILES, AND 3 MILES. ALTERNATE LINE #3 MAY BE DIRECT APPLIED COPY OR APPROPRIATE PLAQUE (SEE DETAIL SHEET W20).

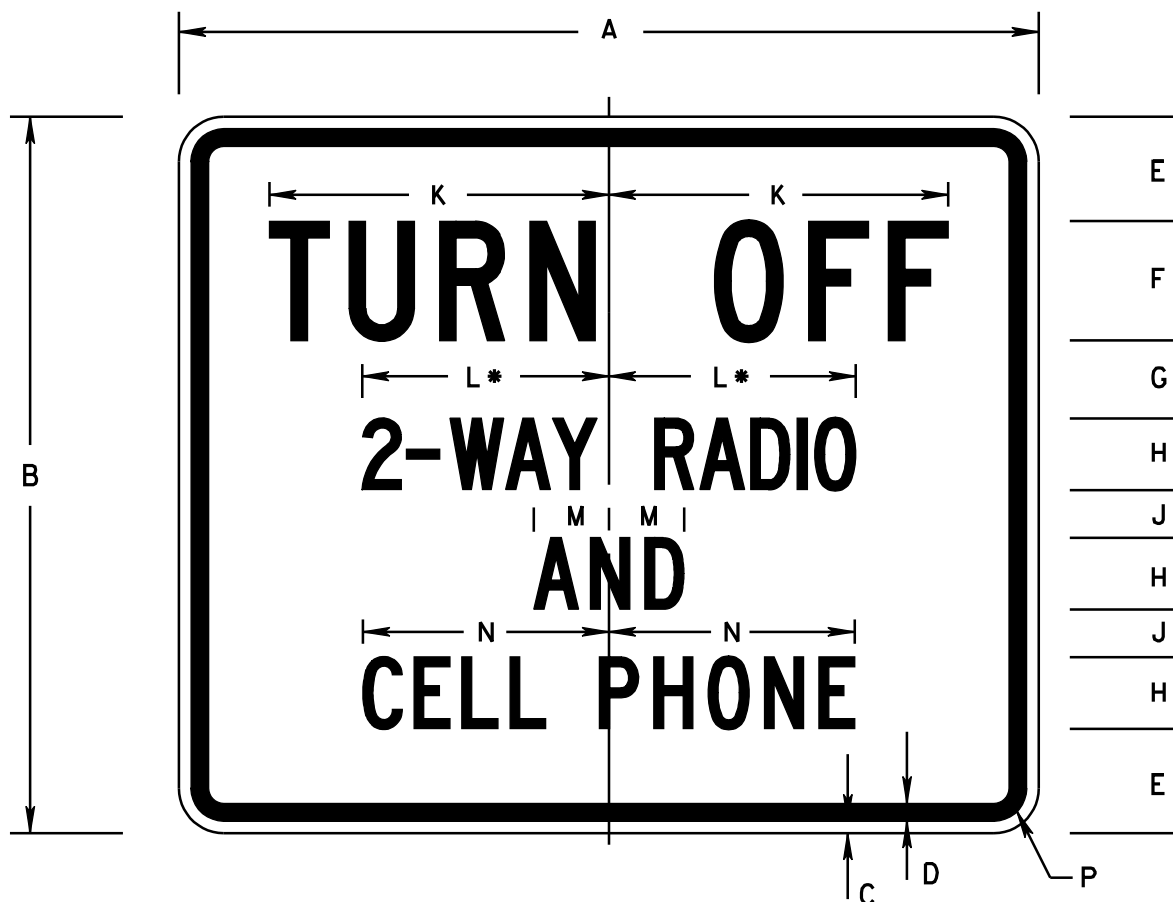

COLORS

LEGEND - BLACK (NON-REF)  
 BACKGROUND - ORANGE (REF)

DIMENSIONS (INCHES)

A	B	C	D	E	F	G	H	J	K	L	M	N	P
36	30	1/2	3/4	4 3/8	5C	3 1/4	3C	2	13 3/8	10 5/16	3 3/16	10 5/16	1 3/8
48	36	5/8	7/8	5	7C	4	4C	1 1/2	18 11/16	13 15/16	4 1/4	13 3/4	1 5/8

\* - REDUCE SPACING TO FIT



COLORS

LEGEND - BLACK (NON-REF)  
 BACKGROUND - ORANGE (REF)

DIMENSIONS (INCHES)

A	B	C	D	E	F	G	H	J	K	L	M	N
36	30	1/2	3/4	4 3/8	5C	3 1/8	4 11/16	5 3/16	11 1/2	11 13/16	6 7/8	1 3/8
42	36	5/8	7/8	4 1/2	7C	3	6 9/16	7 1/4	17 1/2	18	9 11/16	1 5/8

\* - REDUCE SPACING 40%

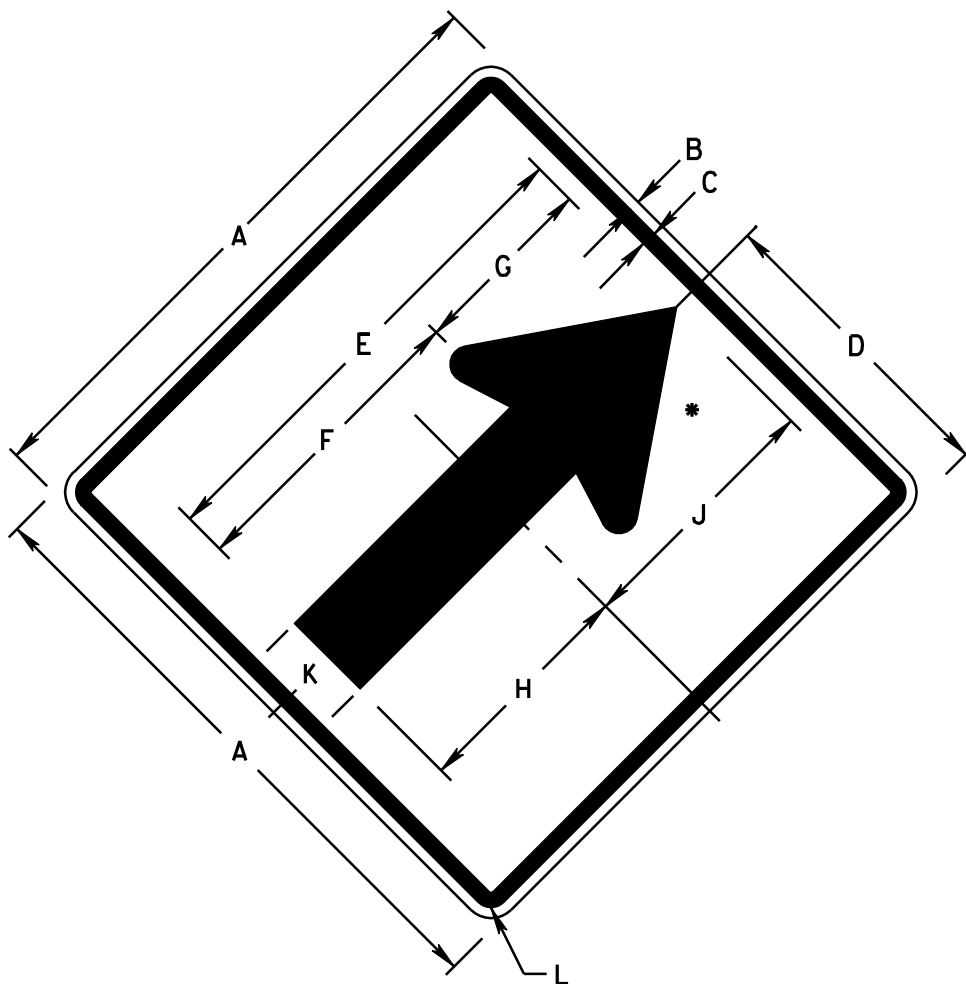

COLORS

LEGEND - BLACK (NON-REF)  
 BACKGROUND - ORANGE (REF)

DIMENSIONS (INCHES)

A	B	C	D	E	F	G	H	J	K	L
30	1/2	3/4	15	24	14 7/8	9 1/8	11 1/4	12 3/4	4 1/2	1 3/8

\* - SEE APPENDIX FOR ARROW DESIGN

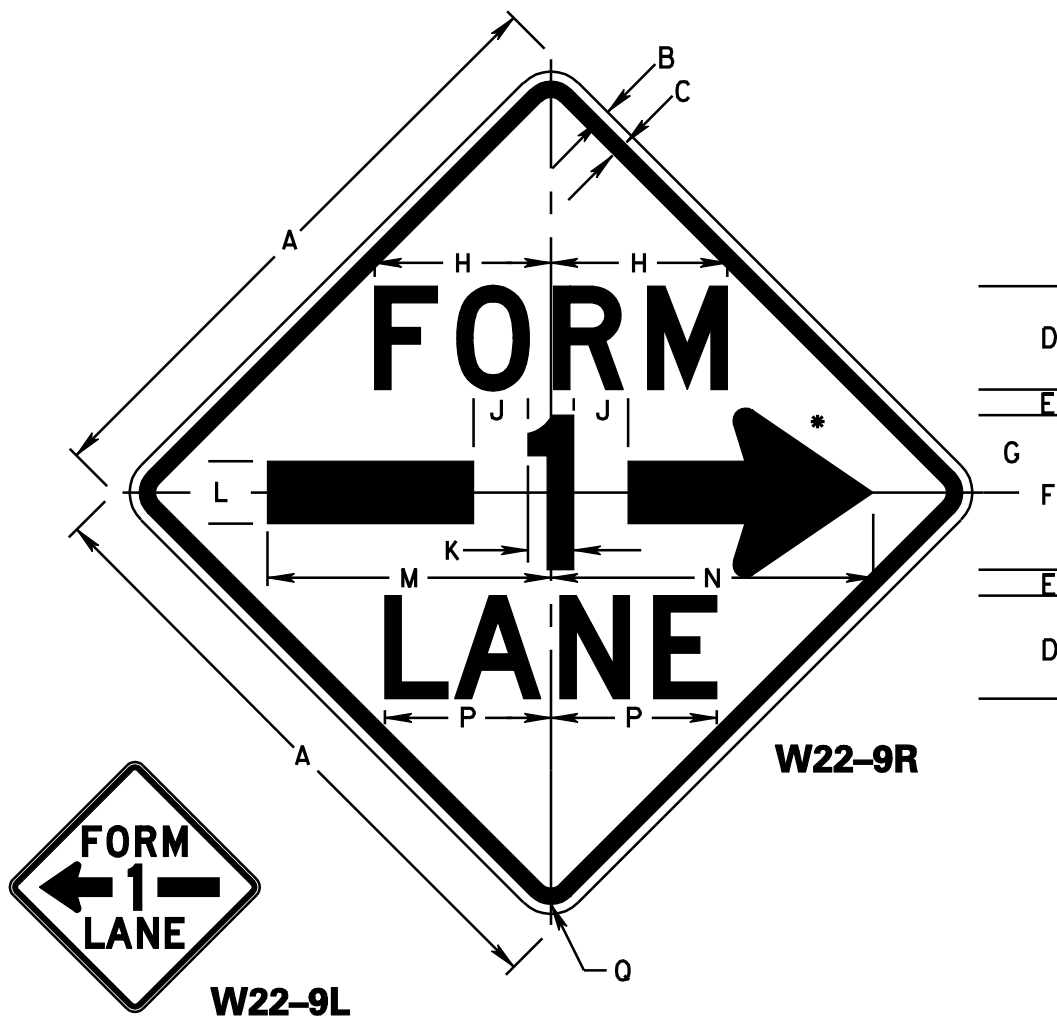

COLORS  
 LEGEND - BLACK (NON-REF)  
 BACKGROUND - ORANGE (REF)

DIMENSIONS (INCHES)

A	B	C	D	E	F	G	H	J	K	L	M	N	P	Q
48	3/4	1 1/4	8D	2	12E	6	13 5/8	6	3 5/8	4 7/8	22	25	12 13/16	2 1/4

\*\* - SEE APPENDIX FOR ARROW DESIGN  
 TO BE USED FOR INCIDENT MANAGEMENT ONLY



COLORS

LEGEND - BLACK (NON-REF)  
 BACKGROUND - ORANGE (REF)

DIMENSIONS (INCHES)

A	B	C	D	E	F	G	H	J	K	L
48	36	5/8	7/8	6 1/2	8E	7	8D	12 3/16	19 1/4	1 5/8

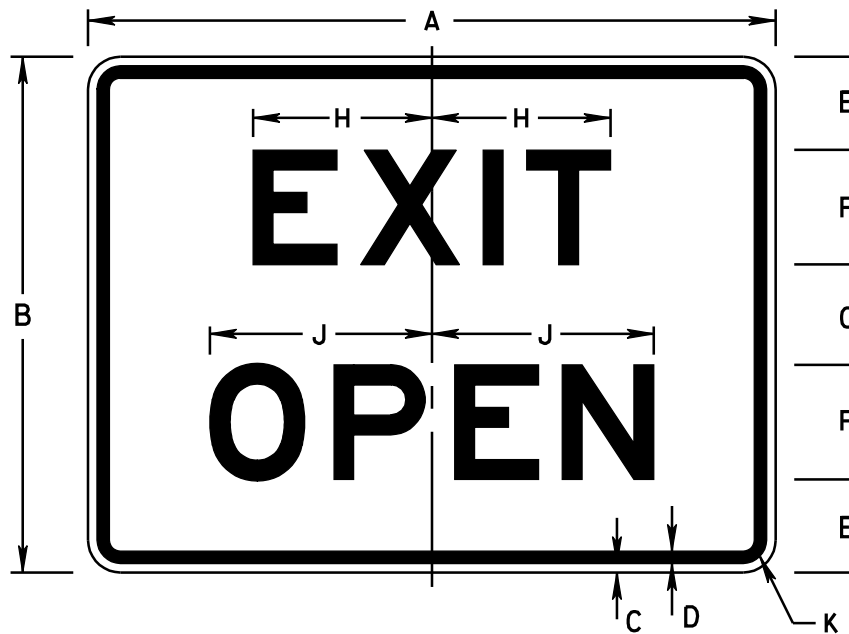

COLORS

LEGEND - BLACK (NON-REF)  
 BACKGROUND - ORANGE (REF)

DIMENSIONS (INCHES)

A	B	C	D	E	F	G	H	J	K
48	36	5/8	7/8	6 1/2	8E	7	12 3/16	15 1/8	1 5/8

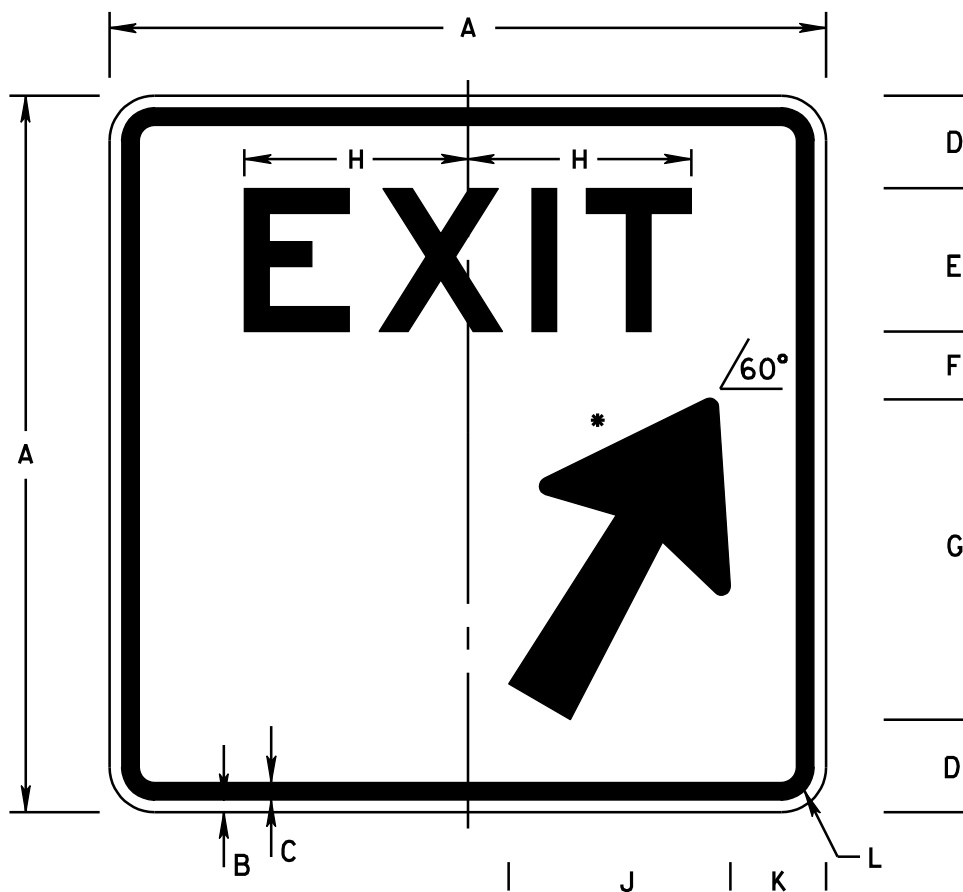

**COLORS**

LEGEND - BLACK (NON-REF)  
 BACKGROUND - ORANGE (REF)

**ALTERNATE COLORS**

LEGEND - WHITE (REF)  
 BACKGROUND - GREEN (REF)

**DIMENSIONS (INCHES)**

A	B	C	D	E	F	G	H	J	K	L
60	1	1 1/2	7 3/4	12E	5 3/4	26 3/4	18 11/16	18 1/2	8	2 3/4

\* - SEE APPENDIX FOR ARROW DESIGN  
 FOR USE IN CONSTRUCTION OR MAINTENANCE OPERATIONS ONLY.  
 WHEN USING THE ALTERNATE COLORS (GREEN/WHITE) THE SIGN  
 SHALL HAVE NO MARGIN, A 1" BORDER, AND A 6" BORDER RADIUS.



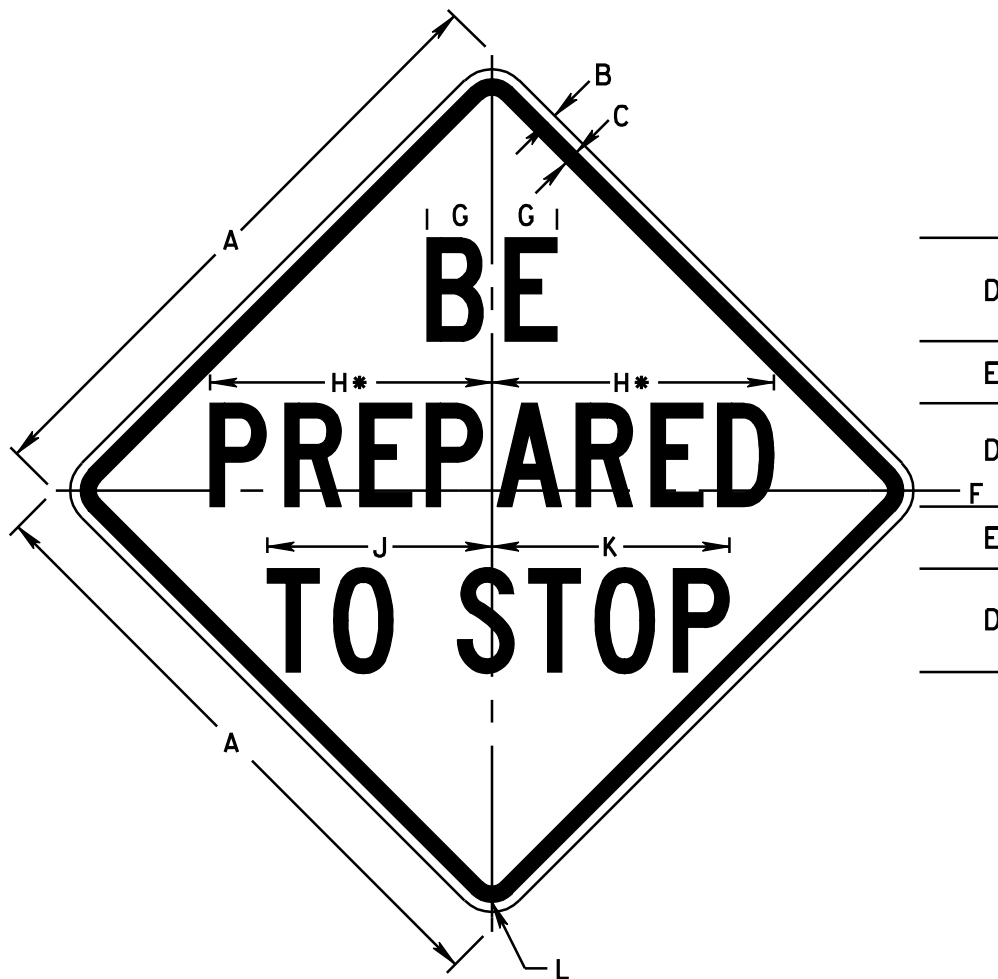

**COLORS**

LEGEND - BLACK (NON-REF)  
 BACKGROUND - ORANGE (REF)

**DIMENSIONS (INCHES)**

A	B	C	D	E	F	G	H	J	K	L
36	5/8	7/8	6C	3 5/8	15/16	3 11/16	16 3/8	13 1/16	13 13/16	1 5/8
48	3/4	1 1/4	8C	4 3/4	1 3/16	4 15/16	21 7/8	17 3/8	18 1/2	2 1/4

\* - REDUCE SPACING 15%

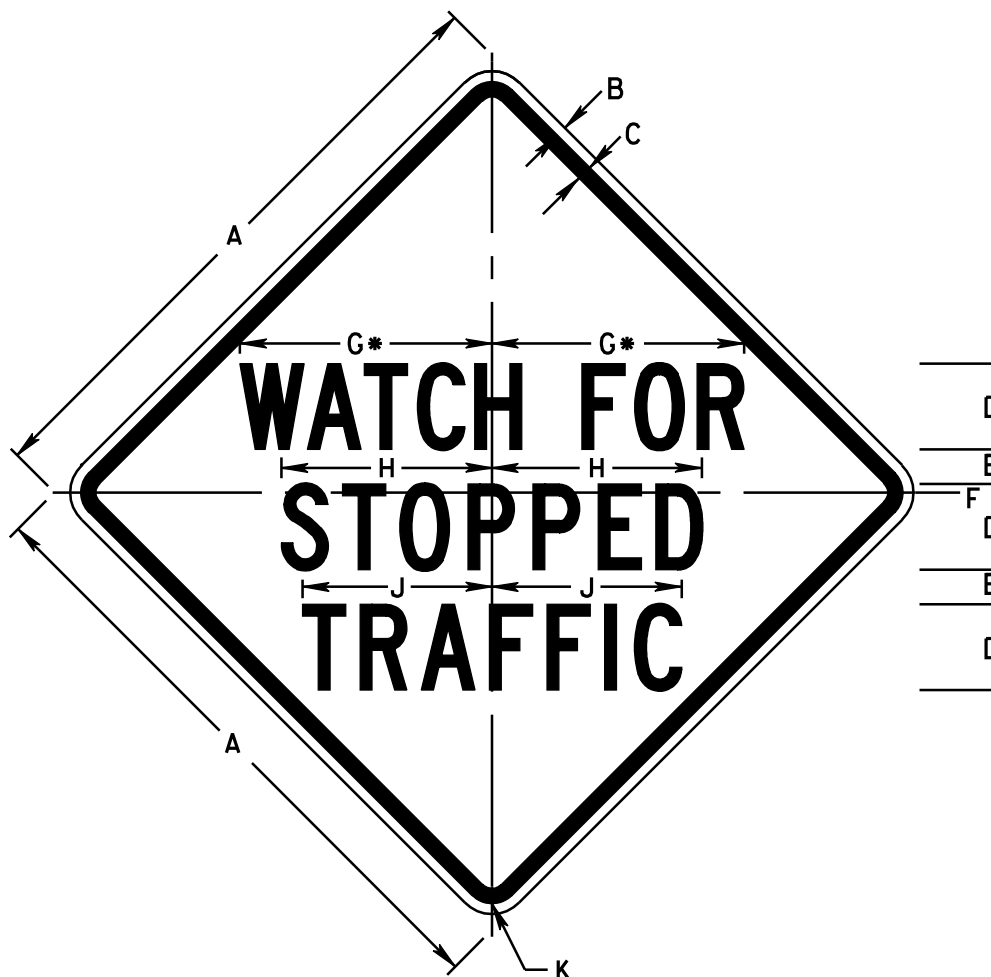

**COLORS**

LEGEND - BLACK (NON-REF)  
 BACKGROUND - ORANGE (REF)

**DIMENSIONS (INCHES)**

A	B	C	D	E	F	G	H	J	K
36	5/8	7/8	5C	2	1/2	14 11/16	12 1/4	11	1 5/8
48	3/4	1 1/4	6C	3	1	18 1/2	14 11/16	13 1/4	2 1/4

\* - 36" REDUCE SPACING 30%

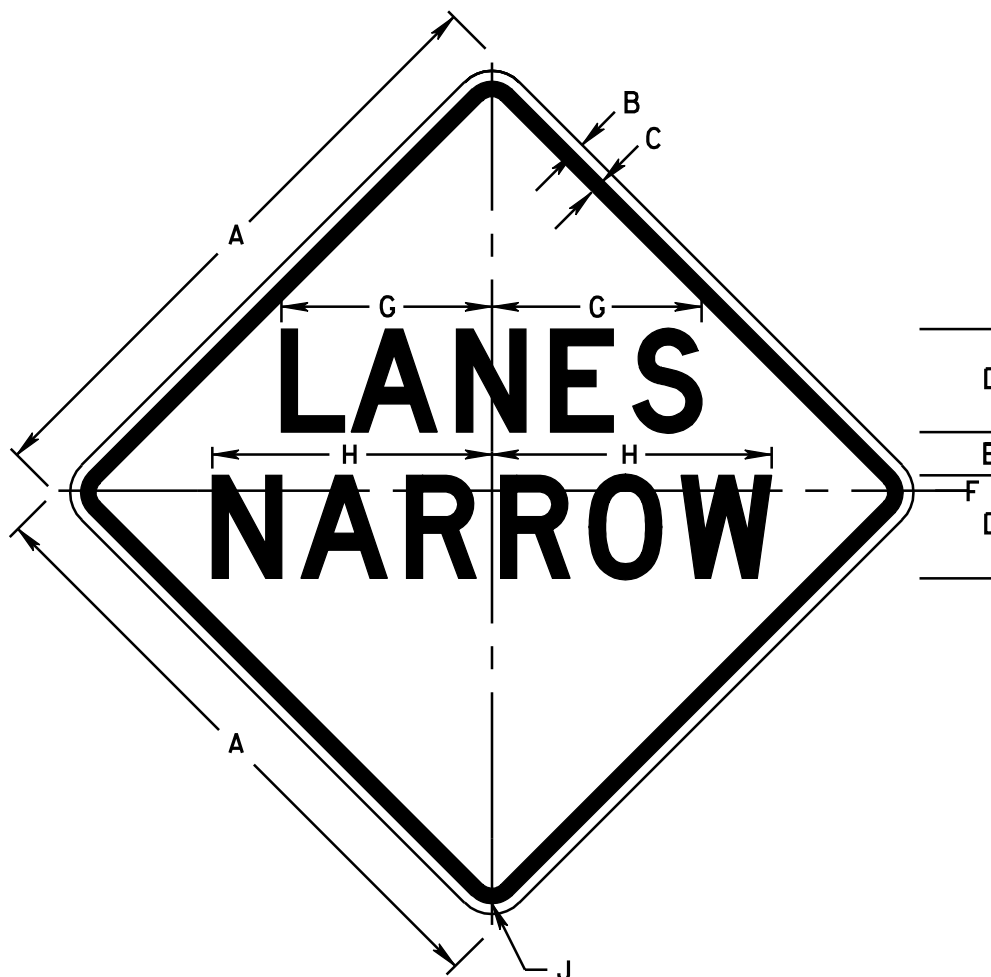

**COLORS**

LEGEND - BLACK (NON-REF)  
 BACKGROUND - ORANGE (REF)

**DIMENSIONS (INCHES)**

A	B	C	D	E	F	G	H	J
36	$\frac{5}{8}$	$\frac{7}{8}$	6D	$2\frac{1}{2}$	1	$12\frac{1}{4}$	$16\frac{1}{4}$	$1\frac{5}{8}$
48	$\frac{3}{4}$	$1\frac{1}{4}$	8D	$3\frac{5}{16}$	$1\frac{5}{16}$	$16\frac{5}{16}$	$21\frac{11}{16}$	$2\frac{1}{4}$

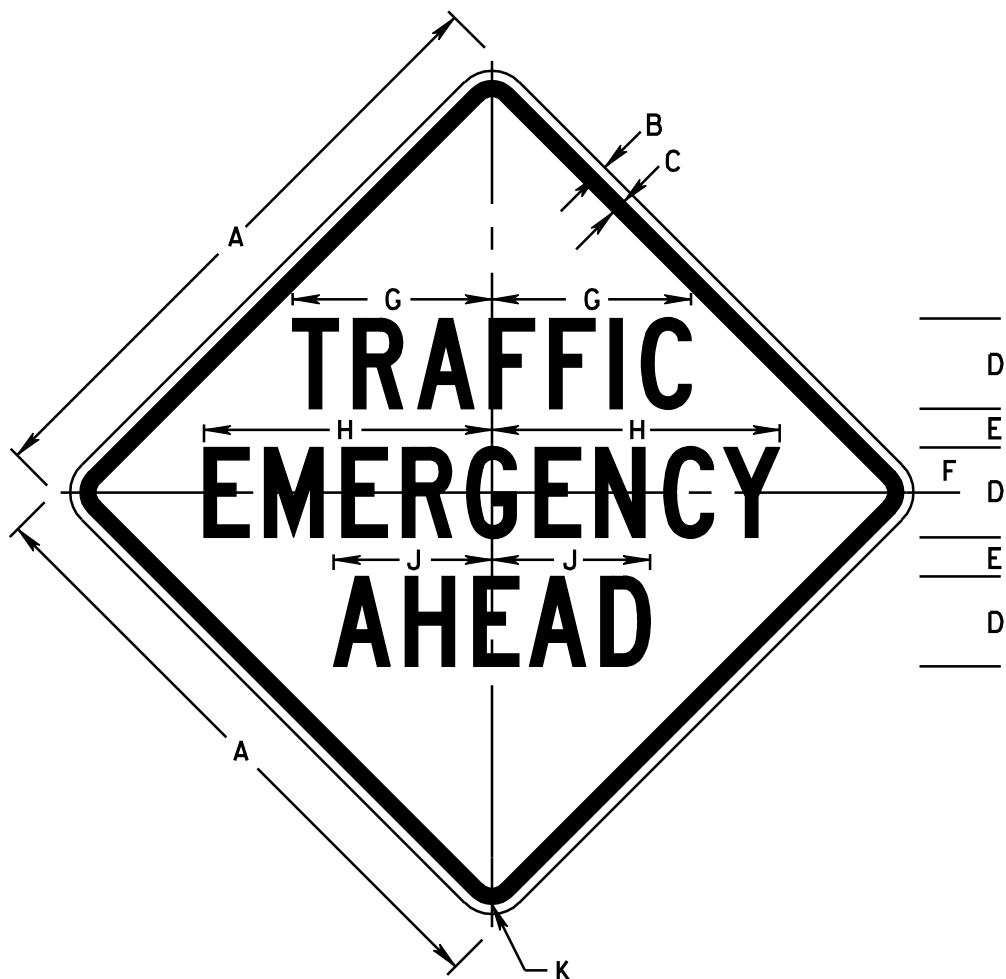

**COLORS**

LEGEND - BLACK (NON-REF)  
 BACKGROUND - ORANGE (REF)

**DIMENSIONS (INCHES)**

A	B	C	D	E	F	G	H	J	K
36	5/8	7/8	5C	2	2 1/2	11	15 15/16	8 3/4	1 5/8
48	3/4	1 1/4	7C	3	3 1/2	15 7/16	22 5/16	12 1/4	2 1/4

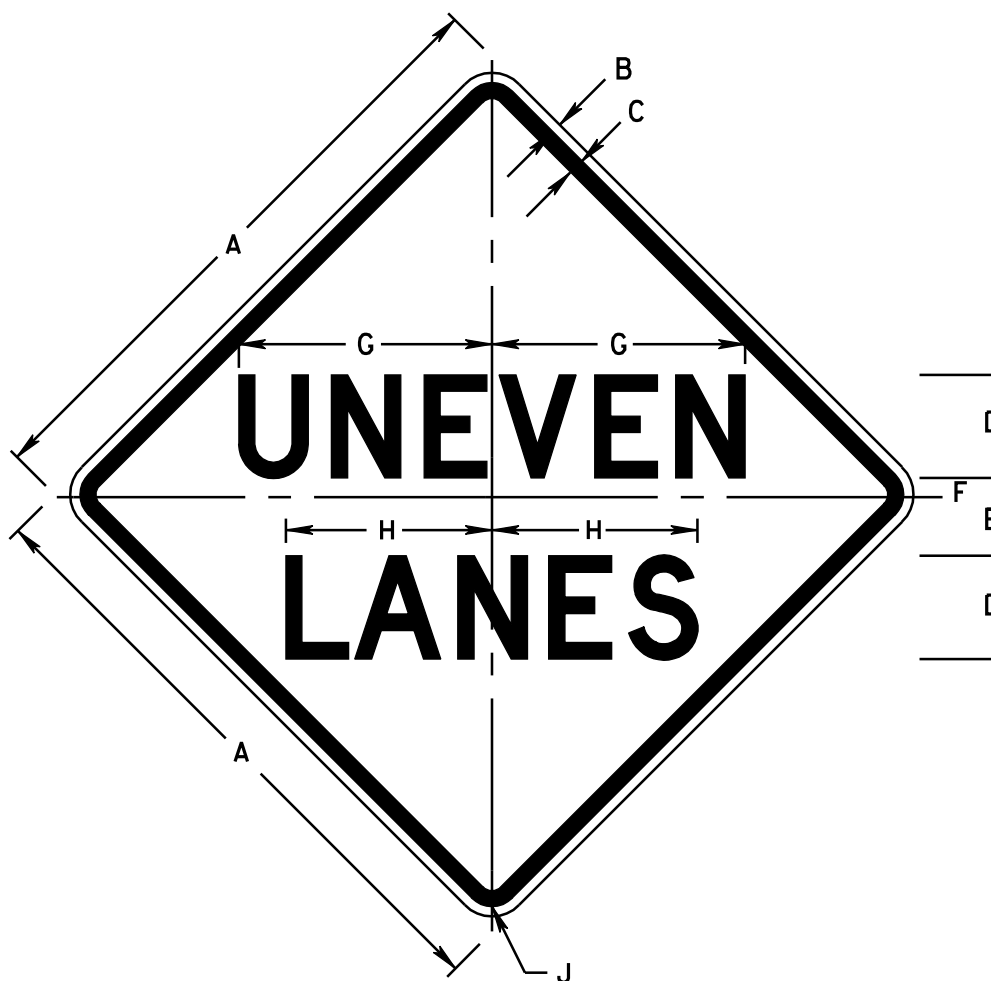

**COLORS**

LEGEND - BLACK (NON-REF)  
 BACKGROUND - ORANGE (REF)

**DIMENSIONS (INCHES)**

A	B	C	D	E	F	G	H	J
36	$\frac{5}{8}$	$\frac{7}{8}$	6D	4 $\frac{1}{2}$	$\frac{15}{16}$	14 $\frac{11}{16}$	12	1 $\frac{5}{8}$
48	$\frac{3}{4}$	1 $\frac{1}{4}$	8D	6	1 $\frac{1}{4}$	19 $\frac{9}{16}$	16	2 $\frac{1}{4}$

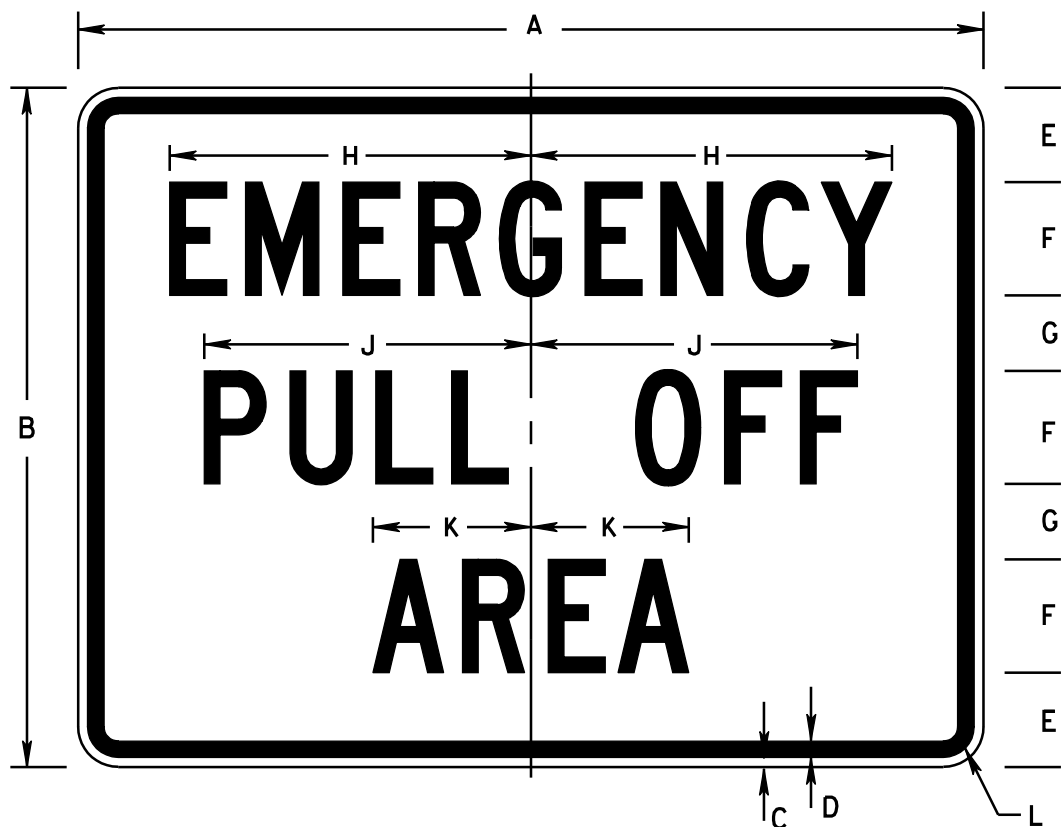

COLORS

LEGEND - BLACK (NON-REF)  
 BACKGROUND - ORANGE (REF)

DIMENSIONS (INCHES)

A	B	C	D	E	F	G	H	J	K	L
48	36	5/8	7/8	5	6C	4	19 1/8	17 5/16	8 3/8	1 5/8