

# 8<sup>TH</sup> STREET BRIDGE ALTERNATIVES

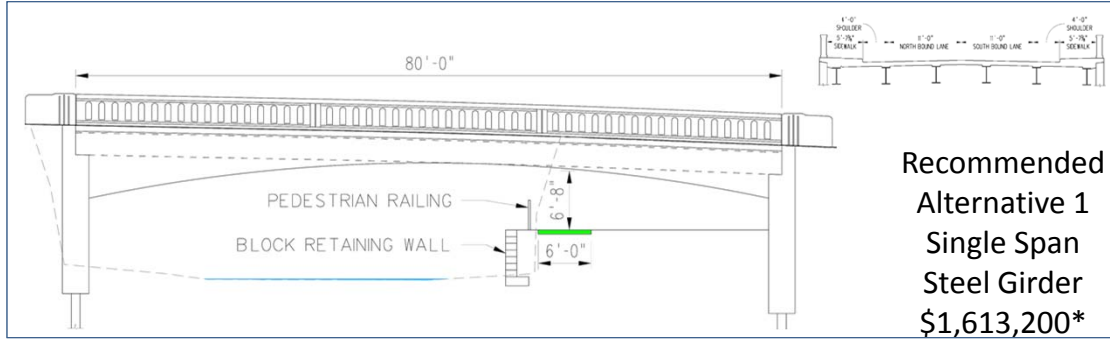

**Recommended  
Alternative 1  
Single Span  
Steel Girder  
\$1,613,200\***

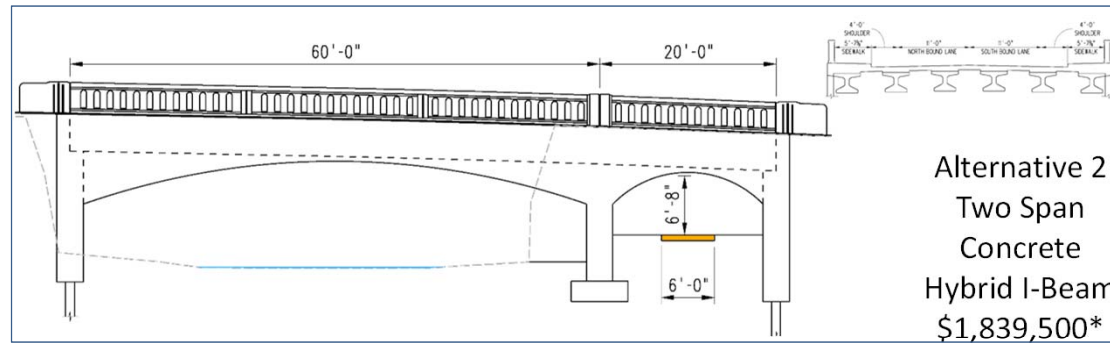

**Alternative 2  
Two Span  
Concrete  
Hybrid I-Beam  
\$1,839,500\***

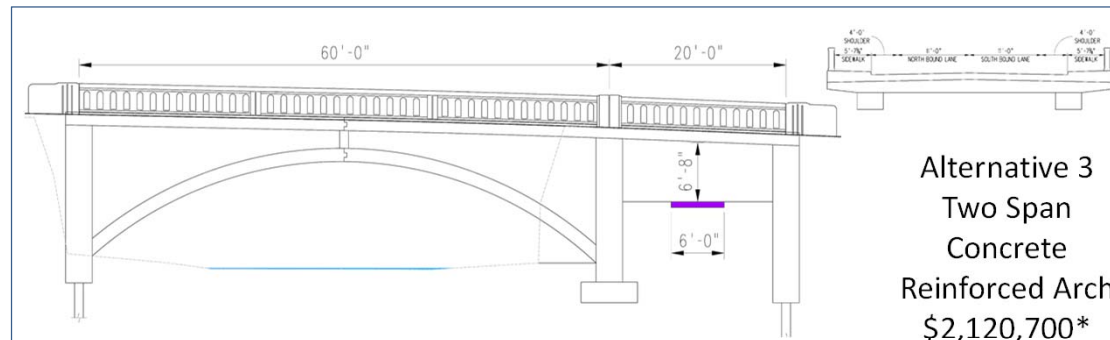

**Alternative 3  
Two Span  
Concrete  
Reinforced Arch  
\$2,120,700\***

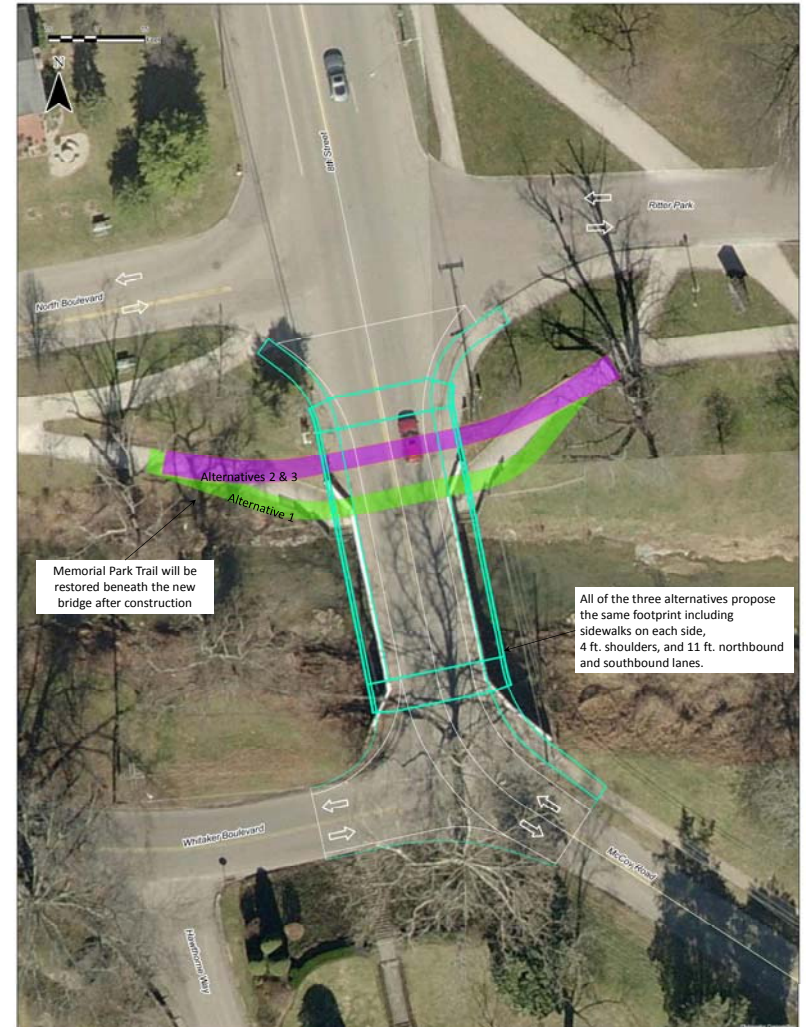

\*Estimated costs subject to change

