



Department of Administration
 Purchasing Division
 2019 Washington Street East
 Post Office Box 50130
 Charleston, WV 25305-0130

**State of West Virginia
 Solicitation Response**

Proc Folder: 1041355
Solicitation Description: ADDENDUM 2: UPS Batteries (81220107)
Proc Type: Agency Master Agreement

Solicitation Closes	Solicitation Response	Version
2022-06-02 14:30	SR 0803 ESR05262200000007495	1

VENDOR
VS0000011412 GRUBER TECHNICAL INC

Solicitation Number: ARFQ 0803 DOT2200000034

Total Bid: 0 **Response Date:** 2022-05-26 **Response Time:** 14:45:19

Comments: Based on the data sheet for the BP12-8 battery, we have determined the actual dimensions are: 6" L x 2.5" W x 4.02" H (please see attachment: "Current Battery Spec Sheet"). Gruber Power Services 12 volt 9 amp hour battery has equivalent dimensions and required specs (please see attachment: "Proposed Battery Spec Sheet"). For the attachment: "Gruber's Formal Battery Quote", this quote includes estimated shipping based on the estimated quantity of 300 batteries, it is understood that the actual order quantity may vary, and thus the shipping cost may also vary.

FOR INFORMATION CONTACT THE BUYER
Dusty J Smith 304-414-6859 dusty.j.smith@wv.gov

**Vendor
 Signature X**

FEIN#

DATE

--

All offers subject to all terms and conditions contained in this solicitation

Line	Comm Ln Desc	Qty	Unit Issue	Unit Price	Ln Total Or Contract Amount
1	UPS Battery 12V 8AH AGM	0.00000	EA	23.450000	0.00

Comm Code	Manufacturer	Specification	Model #
26111700			

Commodity Line Comments:

Extended Description:

UPS Battery 12V 8AH AGM



**State of West Virginia
Agency Request for Quote
Info Technology**

Proc Folder: 1041355	Reason for Modification:
Doc Description: UPS Batteries (81220107)	
Proc Type: Agency Master Agreement	

Date Issued	Solicitation Closes	Solicitation No	Version
2022-05-17	2022-05-31 14:30	ARFQ 0803 DOT2200000034	1

BID RECEIVING LOCATION

BUDGET & PROCUREMENT
DIVISION OF HIGHWAYS
BLDG 5, RM A-260
1900 KANAWHA BLVD E
CHARLESTON WV 25305
US

VENDOR

Vendor Customer Code: VS0000011412
Vendor Name : Gruber Technical Inc. DBA Gruber Power Services
Address : 21439
Street : N. 2nd Ave
City : Phoenix
State : AZ **Country :** USA **Zip :** 85027
Principal Contact : Rita Marie Lomoglio
Vendor Contact Phone: (602) 863-2655 **Extension:** 251

FOR INFORMATION CONTACT THE BUYER

Dusty J Smith
304-414-2063
dusty.j.smith@wv.gov

**Vendor
Signature X**

FEIN# 86-1001733

DATE 5/26/2022

All offers subject to all terms and conditions contained in this solicitation

ADDITIONAL INFORMATION

THE WEST VIRGINIA DEPARTMENT OF TRANSPORTATION- BUDGET AND PROCUREMENT DIVISION - THIS IS AN AGENCY OPEN-ENDED SOLICITATION FOR UPS Batteries PER THE ATTACHED DOCUMENTS.

QUESTIONS REGARDING THE SOLICITATION MUST BE SUBMITTED IN WRITING TO DUSTY.J.SMITH@WV.GOV PRIOR TO THE QUESTION PERIOD DEADLINE CONTAINED IN THE INSTRUCTIONS TO VENDORS SUBMITTING BIDS.

*****NOTICE*****

WE DO NOT ACCEPT EMAIL BIDS

MUST USE ONE THE FOLLOWING TO SUBMIT A BID:

- * UPLOAD TO OASIS
- * HAND DELIVERY
- * MAIL IN HARD COPY

MAKE SURE YOU DOWNLOAD ALL INFORMATION
THE- COMPLETE SOLICITATION-PRICING PAGES-SIGN THE PAGES THAT NEED SIGNED

PLEASE NOTE THAT TO BE AWARDED THIS CONTRACT YOU WILL BE TO A REGISTER VENDOR WITH WV STATE PURCHASING, AND COMPLIANT WITH SEVERAL AGENCIES SUCH AS THE WVSOS, TAX DEPARTMENT, WORKER'S COMPENSATION, AND UNEMPLOYMENT INSURANCE

INVOICE TO		SHIP TO	
DEPT. OF TRANSPORTATION 1900 KANAWHA BLVD E, BLD. 5 RM-720		DEPT. OF TRANSPORTATION 1900 KANAWHA BLVD E, BLD. 5 RM-720	
CHARLESTON	WV	CHARLESTON	WV
US		US	

Line	Comm Ln Desc	Qty	Unit Issue	Unit Price	Total Price
1	UPS Battery 12V 8AH AGM	0.00000	EA	\$23.45	

Comm Code	Manufacturer	Specification	Model #
26111700			

Extended Description:
UPS Battery 12V 8AH AGM

SCHEDULE OF EVENTS

<u>Line</u>	<u>Event</u>	<u>Event Date</u>
1	TECHNICAL QUESTIONS DUE AT 10AM	2022-05-23

**INSTRUCTIONS TO VENDORS SUBMITTING BIDS
(Agency Delegated Procurements Only)**

1. REVIEW DOCUMENTS THOROUGHLY: The attached documents contain a solicitation for bids. Please read these instructions and all documents attached in their entirety. These instructions provide critical information about requirements that if overlooked could lead to disqualification of a Vendor's bid. All bids must be submitted in accordance with the provisions contained in these instructions and the Solicitation. Failure to do so may result in disqualification of Vendor's bid.

2. MANDATORY TERMS: The Solicitation may contain mandatory provisions identified by the use of the words "must," "will," and "shall." Failure to comply with a mandatory term in the Solicitation will result in bid disqualification.

2A. PREBID MEETING: The item identified below shall apply to this Solicitation.

A pre-bid meeting will not be held prior to bid opening

A MANDATORY PRE-BID meeting will be held at the following place and time:

All Vendors submitting a bid must attend the mandatory pre-bid meeting. Failure to attend the mandatory pre-bid meeting shall result in disqualification of the Vendor's bid. No one individual is permitted to represent more than one vendor at the pre-bid meeting. Any individual that does attempt to represent two or more vendors will be required to select one vendor to which the individual's attendance will be attributed. The vendors not selected will be deemed to have not attended the pre-bid meeting unless another individual attended on their behalf. The required attribution of attendance to a single vendor should be addressed during the pre-bid but may occur at any time deemed appropriate by the Purchasing Division.

An attendance sheet provided at the pre-bid meeting shall serve as the official document verifying attendance. Any person attending the pre-bid meeting on behalf of a Vendor must list on the attendance sheet his or her name and the name of the Vendor he or she is representing.

Additionally, the person attending the pre-bid meeting should include the Vendor's E-Mail address, phone number, and Fax number on the attendance sheet. It is the Vendor's responsibility to locate the attendance sheet and provide the required information. Failure to complete the attendance sheet as required may result in disqualification of Vendor's bid.

All Vendors should arrive prior to the starting time for the pre-bid. Vendors who arrive after the starting time but prior to the end of the pre-bid will be permitted to sign in, but are charged with knowing all matters discussed at the pre-bid.

Questions submitted at least five business days prior to a scheduled pre-bid will be discussed at

the pre-bid meeting if possible. Any discussions or answers to questions at the pre-bid meeting are preliminary in nature and are non-binding. Official and binding answers to questions will be published in a written addendum to the Solicitation prior to bid opening.

3. BID SUBMISSION: All bids must be submitted electronically through wvOASIS or signed and delivered by the Vendor to the Agency on or before the date and time of the bid opening. Any bid received by the Agency staff is considered to be in the possession of the Agency and will not be returned for any reason.

3A. BID SUBMISSION

A bid that is not submitted electronically through wvOASIS should contain the information listed below on the face of the envelope or the bid may be rejected by the Agency.

SEALED BID:

BUYER:

SOLICITATION NO.:

BID OPENING DATE:

BID OPENING TIME:

FAX NUMBER:

4. ADDENDUM ACKNOWLEDGEMENT: Changes or revisions to this Solicitation will be made by an official addendum issued by the Agency. Vendor should acknowledge receipt of all addenda issued with this Solicitation by completing an Addendum Acknowledgment Form, a copy of which is included herewith. Failure to acknowledge addenda may result in bid disqualification. The addendum acknowledgement should be submitted with the bid to expedite document processing.

5. BID FORMATTING: Vendor should type or electronically enter the information onto its bid to prevent errors in the evaluation. Failure to type or electronically enter the information may result in bid disqualification.

6. ALTERNATE MODEL OR BRAND: Unless the box below is checked, any model, brand, or specification listed in this Solicitation establishes the acceptable level of quality only and is not intended to reflect a preference for, or in any way favor, a particular brand or vendor. Vendors may bid alternates to a listed model or brand provided that the alternate is at least equal to the model or brand and complies with the required specifications. The equality of any alternate being bid shall be determined by the State at its sole discretion. Any Vendor bidding an alternate model or brand should clearly identify the alternate items in its bid and should include manufacturer's specifications, industry literature, and/or any other relevant documentation demonstrating the equality of the alternate items. Failure to provide information for alternate items may be grounds for rejection of a Vendor's bid.

[] This Solicitation is based upon a standardized commodity established under West Virginia Code § 5A-3-61. Vendors are expected to bid the standardized commodity identified. Failure to bid the standardized commodity will result in your firm's bid being rejected.

7. EXCEPTIONS AND CLARIFICATIONS: The Solicitation contains the specifications that shall form the basis of a contractual agreement. Vendor shall clearly mark any exceptions,
Revised 04/01/2022

clarifications, or other proposed modifications in its bid. Exceptions to, clarifications of, or modifications of a requirement or term and condition of the Solicitation may result in bid disqualification.

8. REGISTRATION: Prior to Contract award, the apparent successful Vendor must be properly registered with the West Virginia Purchasing Division and must have paid the \$125 fee, if applicable.

9. UNIT PRICE: Unit prices shall prevail in cases of a discrepancy in the Vendor's bid.

10. PREFERENCE: Vendor Preference may be requested in purchases of motor vehicles or construction and maintenance equipment and machinery used in highway and other infrastructure projects. Any request for preference must be submitted in writing with the bid, must specifically identify the preference requested with reference to the applicable subsection of West Virginia Code § 5A-3-37, and must include with the bid any information necessary to evaluate and confirm the applicability of the requested preference. A request form to help facilitate the request can be found at: <http://www.state.wv.us/admin/purchase/vrc/Venpref.pdf>.

10A. RECIPROCAL PREFERENCE: The State of West Virginia applies a reciprocal preference to all solicitations for commodities and printing in accordance with W. Va. Code § 5A-3-37(b). In effect, if reciprocal preference is requested by a West Virginia resident vendor, non-resident vendors receiving a preference in their home states, will see that same preference granted to West Virginia resident vendors bidding against them in West Virginia. Any request for reciprocal preference must include with the bid any information necessary to evaluate and confirm the applicability of the preference. A request form to help facilitate the request can be found at: <http://www.state.wv.us/admin/purchase/vrc/Venpref.pdf>.

11. SMALL, WOMEN-OWNED, OR MINORITY-OWNED BUSINESSES: For any solicitations publicly advertised for bid, in accordance with West Virginia Code §5A-3-37(a)(7) and W. Va. CSR § 148-22-9, any non-resident vendor certified as a small, women-owned, or minority-owned business under W. Va. CSR § 148-22-9 shall be provided the same preference made available to any resident vendor. Any non-resident small, women-owned, or minority-owned business must identify itself as such in writing, must submit that writing to the Purchasing Division with its bid, and must be properly certified under W. Va. CSR § 148-22-9 prior to contract award to receive the preferences made available to resident vendors. Preference for a non-resident small, women-owned, or minority owned business shall be applied in accordance with W. Va. CSR § 148-22-9.

12. ELECTRONIC FILE ACCESS RESTRICTIONS: Vendor must ensure that its submission in wvOASIS can be accessed and viewed by the Agency staff immediately upon bid opening. The Agency will consider any file that cannot be immediately access and viewed at the time of the bid opening (such as, encrypted files, password protected files, or incompatible files) to be blank or incomplete as context requires, and therefore unacceptable. A vendor will not be permitted to unencrypt files, remove password protections, or resubmit documents after bid opening to make a file viewable if those documents are required with the bid. A Vendor may be required to provide document passwords or removed access restrictions to allow the Agency to print or electronically save documents provided that those documents are viewable by the Agency prior to obtaining the password or removing the access restriction.

13. NON-RESPONSIBLE: The Purchasing Division Director reserves the right to reject the bid of any vendor as Non-Responsible in accordance with W. Va. Code of State Rules § 148-1-5.3, when the Director determines that the vendor submitting the bid does not have the capability to fully perform, or lacks the integrity and reliability to assure good-faith performance.”

14. ACCEPTANCE/REJECTION: The State may accept or reject any bid in whole, or in part in accordance with W. Va. Code of State Rules § 148-1-4.5. and § 148-1-6.4.b.”

15. YOUR SUBMISSION IS A PUBLIC DOCUMENT: Vendor’s entire response to the Solicitation and the resulting Contract are public documents. As public documents, they will be disclosed to the public following the bid/proposal opening or award of the contract, as required by the competitive bidding laws of West Virginia Code §§ 5A-3-1 et seq., 5-22-1 et seq., 5G-1-1 et seq. and the Freedom of Information Act in West Virginia Code §§ 29B-1-1 et seq.

DO NOT SUBMIT MATERIAL YOU CONSIDER TO BE CONFIDENTIAL, A TRADE SECRET, OR OTHERWISE NOT SUBJECT TO PUBLIC DISCLOSURE.

Submission of any bid, proposal, or other document to the Purchasing Division constitutes your explicit consent to the subsequent public disclosure of the bid, proposal, or document. The Purchasing Division will disclose any document labeled “confidential,” “proprietary,” “trade secret,” “private,” or labeled with any other claim against public disclosure of the documents, to include any “trade secrets” as defined by West Virginia Code § 47-22-1 et seq. All submissions are subject to public disclosure without notice.

**GENERAL TERMS AND CONDITIONS:
(Agency Delegated Procurements Only)**

1. CONTRACTUAL AGREEMENT: Issuance of an Award Document signed by the Agency and approved as to form by the Attorney General's office, if required, constitutes acceptance by the State of this Contract made by and between the State of West Virginia and the Vendor. Vendor's signature on its bid, or on the Contract if the Contract is not the result of a bid solicitation, signifies Vendor's agreement to be bound by and accept the terms and conditions contained in this Contract.

2. DEFINITIONS: As used in this Solicitation/Contract, the following terms shall have the meanings attributed to them below. Additional definitions may be found in the specifications included with this Solicitation/Contract.

2.1. "Agency" or "Agencies" means the agency, board, commission, or other entity of the State of West Virginia that is identified on the first page of the Solicitation or any other public entity seeking to procure goods or services under this Contract.

2.2. "Bid" or "Proposal" means the vendors submitted response to this solicitation.

2.3. "Contract" means the binding agreement that is entered into between the State and the Vendor to provide the goods or services requested in the Solicitation.

2.4. "Director" means the Director of the West Virginia Department of Administration, Purchasing Division.

2.5. "Purchasing Division" means the West Virginia Department of Administration, Purchasing Division.

2.6. "Award Document" means the document signed by the Agency that identifies the Vendor as the contract holder.

2.7. "Solicitation" means the official notice of an opportunity to supply the State with goods or services.

2.8. "State" means the State of West Virginia and/or any of its agencies, commissions, boards, etc. as context requires.

2.9. "Vendor" or "Vendors" means any entity submitting a bid in response to the Solicitation, the entity that has been selected as the lowest responsible bidder, or the entity that has been awarded the Contract as context requires.

3. CONTRACT TERM; RENEWAL; EXTENSION: The term of this Contract shall be determined in accordance with the category that has been identified as applicable to this Contract below:

Term Contract

Initial Contract Term: This Contract becomes effective on _____
Upon Award Date _____ and the initial contract term extends until _____ One (1) Year after Award _____.

Renewal Term: This Contract may be renewed upon the mutual written consent of the Agency, and the Vendor. Any request for renewal should be delivered to the Agency thirty (30) days prior to the expiration date of the initial contract term or appropriate renewal term. A Contract renewal shall be in accordance with the terms and conditions of the original contract. Unless otherwise specified below, renewal of this Contract is limited to Zero (0) successive one (1) year periods or multiple renewal periods of less than one year, provided that the multiple renewal periods do not exceed the total number of months available in all renewal years combined. Automatic renewal of this Contract is prohibited.

Alternate Renewal Term – This contract may be renewed for _____ successive _____ year periods or shorter periods provided that they do not exceed the total number of months contained in all available renewals. Automatic renewal of this Contract is prohibited. Renewals must be approved by the Vendor and Agency.

Delivery Order Limitations: In the event that this contract permits delivery orders, a delivery order may only be issued during the time this Contract is in effect. Any delivery order issued within one year of the expiration of this Contract shall be effective for one year from the date the delivery order is issued. No delivery order may be extended beyond one year after this Contract has expired.

Fixed Period Contract: This Contract becomes effective upon Vendor's receipt of the notice to proceed and must be completed within _____ days.

Fixed Period Contract with Renewals: This Contract becomes effective upon Vendor's receipt of the notice to proceed and part of the Contract more fully described in the attached specifications must be completed within _____ days. Upon completion of the work covered by the preceding sentence, the vendor agrees that maintenance, monitoring, or warranty services will be provided for _____ year(s) thereafter.

One Time Purchase: The term of this Contract shall run from the issuance of the Award Document until all of the goods contracted for have been delivered, but in no event will this Contract extend for more than one fiscal year.

Other: See attached.

4. AUTHORITY TO PROCEED: Vendor is authorized to begin performance of this contract on the date of encumbrance listed on the front page of the Award Document unless either the box for “Fixed Period Contract” or “Fixed Period Contract with Renewals” has been checked in Section 3 above. If either “Fixed Period Contract” or “Fixed Period Contract with Renewals” has been checked, Vendor must not begin work until it receives a separate notice to proceed from the State. The notice to proceed will then be incorporated into the Contract via change order to memorialize the official date that work commenced.

5. QUANTITIES: The quantities required under this Contract shall be determined in accordance with the category that has been identified as applicable to this Contract below.

Open End Contract: Quantities listed in this Solicitation/Award Document are approximations only, based on estimates supplied by the Agency. It is understood and agreed that the Contract shall cover the quantities actually ordered for delivery during the term of the Contract, whether more or less than the quantities shown.

Service: The scope of the service to be provided will be more clearly defined in the specifications included herewith.

Combined Service and Goods: The scope of the service and deliverable goods to be provided will be more clearly defined in the specifications included herewith.

One Time Purchase: This Contract is for the purchase of a set quantity of goods that are identified in the specifications included herewith. Once those items have been delivered, no additional goods may be procured under this Contract without an appropriate change order approved by the Vendor, Agency, Purchasing Division, and Attorney General’s office.

6. EMERGENCY PURCHASES: The Purchasing Division Director may authorize the Agency to purchase goods or services in the open market that Vendor would otherwise provide under this Contract if those goods or services are for immediate or expedited delivery in an emergency. Emergencies shall include, but are not limited to, delays in transportation or an unanticipated increase in the volume of work. An emergency purchase in the open market, approved by the Purchasing Division Director, shall not constitute a breach of this Contract and shall not entitle the Vendor to any form of compensation or damages. This provision does not excuse the State from fulfilling its obligations under a One Time Purchase contract.

7. REQUIRED DOCUMENTS: All of the items checked below must be provided to the Agency by the Vendor as specified below.

PERFORMANCE BOND: The apparent successful Vendor shall provide a performance bond in the amount of 100% of the contract value. The performance bond must be received by the Agency prior to Contract award.

LABOR/MATERIAL PAYMENT BOND: The apparent successful Vendor shall provide a labor/material payment bond in the amount of 100% of the Contract value. The labor/material payment bond must be received by the Agency prior to Contract award.

MAINTENANCE BOND: The apparent successful Vendor shall provide a two (2) year maintenance bond covering the roofing system. The maintenance bond must be issued and delivered to the Agency prior to Contract award.

LICENSE(S) / CERTIFICATIONS / PERMITS: In addition to anything required under the Section of the General Terms and Conditions entitled Licensing, the apparent successful Vendor shall furnish proof of the following licenses, certifications, and/or permits upon request and in a form acceptable to the State. The request may be prior to or after contract award at the State's sole discretion.

The apparent successful Vendor shall also furnish proof of any additional licenses or certifications contained in the specifications regardless of whether or not that requirement is listed above.

8. INSURANCE: The apparent successful Vendor shall furnish proof of the insurance identified by a checkmark below and must include the State as an additional insured on each policy prior to Contract award. The insurance coverages identified below must be maintained throughout the life of this contract. Thirty (30) days prior to the expiration of the insurance policies Vendor shall provide the Agency with proof that the insurance mandated herein has been continued. Vendor must also provide Agency with immediate notice of any changes in its insurance policies, including but not limited to, policy cancelation, policy reduction, or change in insurers. The apparent successful Vendor shall also furnish proof of any additional insurance requirements contained in the specifications prior to Contract award regardless of whether or not that insurance requirement is listed in this section.

Vendor must maintain:

Commercial General Liability Insurance in at least an amount of:
\$1,000,000.00 per occurrence.

Automobile Liability Insurance in at least an amount of: _____ per occurrence.

Professional/Malpractice/Errors and Omission Insurance in at least an amount of: _____ per occurrence. Notwithstanding the forgoing, Vendor's are not required to list the State as an additional insured for this type of policy.

Commercial Crime and Third Party Fidelity Insurance in an amount of: _____ per occurrence.

Cyber Liability Insurance in an amount of: _____ per occurrence.

Builders Risk Insurance in an amount equal to 100% of the amount of the Contract.

Pollution Insurance in an amount of: _____ per occurrence.

Aircraft Liability in an amount of: _____ per occurrence.

State of WV must be listed as additional insured on insurance certificate

Certificate Holder should read as follows:
State of WV
1900 Kanawha Blvd E, Charleston, WV 25305

9. WORKERS' COMPENSATION INSURANCE: Vendor shall comply with laws relating to workers compensation, shall maintain workers' compensation insurance when required, and shall furnish proof of workers' compensation insurance upon request.

10. LIQUIDATED DAMAGES: This clause shall in no way be considered exclusive and shall not limit the State or Agency's right to pursue any other available remedy. Vendor shall pay liquidated damages in the amount specified below or as described in the specifications:

_____ for _____

Liquidated Damages Contained in the Specifications.

Liquidated Damages Are Not Included in this Contract.

11. ACCEPTANCE: Vendor's signature on its bid, or on the certification and signature page, constitutes an offer to the State that cannot be unilaterally withdrawn, signifies that the product or service proposed by vendor meets the mandatory requirements contained in the Solicitation for that product or service, unless otherwise indicated, and signifies acceptance of the terms and conditions contained in the Solicitation unless otherwise indicated.

12. PRICING: The pricing set forth herein is firm for the life of the Contract, unless specified elsewhere within this Solicitation/Contract by the State. A Vendor's inclusion of price adjustment provisions in its bid, without an express authorization from the State in the Solicitation to do so, may result in bid disqualification. Notwithstanding the foregoing, Vendor must extend any publicly advertised sale price to the State and invoice at the lower of the contract price or the publicly advertised sale price.

13. PAYMENT IN ARREARS: Payments for goods/services will be made in arrears only upon receipt of a proper invoice, detailing the goods/services provided or receipt of the goods/services, whichever is later. Notwithstanding the foregoing, payments for software licenses, subscriptions, or maintenance may be paid annually in advance.

14. PAYMENT METHODS: Vendor must accept payment by electronic funds transfer or P-Card. (The State of West Virginia's Purchasing Card program, administered under contract by a banking institution, processes payment for goods and services through state designated credit cards.)

15. ADDITIONAL FEES: Vendor is not permitted to charge additional fees or assess additional charges that were not either expressly provided for in the solicitation published by the State of West Virginia, included in the Contract, or included in the unit price or lump sum bid amount that Vendor is required by the solicitation to provide. Including such fees or charges as notes to the solicitation may result in rejection of vendor's bid. Requesting such fees or charges be paid after the contract has been awarded may result in cancellation of the contract.

16. TAXES: The Vendor shall pay any applicable sales, use, personal property or any other taxes arising out of this Contract and the transactions contemplated thereby. The State of West Virginia is exempt from federal and state taxes and will not pay or reimburse such taxes.

17. FUNDING: This Contract shall continue for the term stated herein, contingent upon funds being appropriated by the Legislature or otherwise being made available. In the event funds are not appropriated or otherwise made available, this Contract becomes void and of no effect beginning on July 1 of the fiscal year for which funding has not been appropriated or otherwise made available. If that occurs, the State may notify the Vendor that an alternative source of funding has been obtained and thereby avoid the automatic termination. Non-appropriation or non-funding shall not be considered an event of default.

18. CANCELLATION: The State reserves the right to cancel this Contract immediately upon written notice to the vendor if the materials or workmanship supplied do not conform to the specifications contained in the Contract. The Agency may also cancel any purchase or Contract upon 30 days written notice to the Vendor in accordance with West Virginia Code of State Rules § 148-1-5.2.b.

19. TIME: Time is of the essence with regard to all matters of time and performance in this Contract.

20. APPLICABLE LAW: This Contract is governed by and interpreted under West Virginia law without giving effect to its choice of law principles. Any information provided in specification manuals, or any other source, verbal or written, which contradicts or violates the West Virginia Constitution, West Virginia Code or West Virginia Code of State Rules is void and of no effect.

21. COMPLIANCE WITH LAWS: Vendor shall comply with all applicable federal, state, and local laws, regulations and ordinances. By submitting a bid, Vendor acknowledges that it has reviewed, understands, and will comply with all applicable laws, regulations, and ordinances. Vendor shall notify all subcontractors providing commodities or services related to this Contract that as subcontractors, they too are required to comply with all applicable laws, regulations, and ordinances.

22. ARBITRATION: Any references made to arbitration contained in this Contract, Vendor's bid, or in any American Institute of Architects documents pertaining to this Contract are hereby deleted, void, and of no effect.

23. MODIFICATIONS: This writing is the parties' final expression of intent. Notwithstanding anything contained in this Contract to the contrary, no modification of this Contract shall be binding without mutual written consent of the Agency, and the Vendor.

24. WAIVER: The failure of either party to insist upon a strict performance of any of the terms or provision of this Contract, or to exercise any option, right, or remedy herein contained, shall not be construed as a waiver or a relinquishment for the future of such term, provision, option, right, or remedy, but the same shall continue in full force and effect. Any waiver must be expressly stated in writing and signed by the waiving party.

25. SUBSEQUENT FORMS: The terms and conditions contained in this Contract shall supersede any and all subsequent terms and conditions which may appear on any form documents submitted by Vendor to the Agency or Purchasing Division such as price lists, order forms, invoices, sales agreements, or maintenance agreements, and includes internet websites or other electronic documents. Acceptance or use of Vendor's forms does not constitute acceptance of the terms and conditions contained thereon.

26. ASSIGNMENT: Neither this Contract nor any monies due, or to become due hereunder, may be assigned by the Vendor without the express written consent of the Agency and any other government agency or office that may be required to approve such assignments.

27. WARRANTY: The Vendor expressly warrants that the goods and/or services covered by this Contract will: (a) conform to the specifications, drawings, samples, or other description furnished or specified by the Agency; (b) be merchantable and fit for the purpose intended; and (c) be free from defect in material and workmanship.

28. STATE EMPLOYEES: State employees are not permitted to utilize this Contract for personal use and the Vendor is prohibited from permitting or facilitating the same.

29. PRIVACY, SECURITY, AND CONFIDENTIALITY: The Vendor agrees that it will not disclose to anyone, directly or indirectly, any such personally identifiable information or other confidential information gained from the Agency, unless the individual who is the subject of the information consents to the disclosure in writing or the disclosure is made pursuant to the Agency's policies, procedures, and rules. Vendor further agrees to comply with the Confidentiality Policies and Information Security Accountability Requirements, set forth in www.state.wv.us/admin/purchase/privacy.

30. YOUR SUBMISSION IS A PUBLIC DOCUMENT: Vendor's entire response to the Solicitation and the resulting Contract are public documents. As public documents, they will be disclosed to the public following the bid/proposal opening or award of the contract, as required by the competitive bidding laws of West Virginia Code §§ 5A-3-1 et seq., 5-22-1 et seq., and 5G-1-1 et seq. and the Freedom of Information Act West Virginia Code §§ 29B-1-1 et seq.

DO NOT SUBMIT MATERIAL YOU CONSIDER TO BE CONFIDENTIAL, A TRADE SECRET, OR OTHERWISE NOT SUBJECT TO PUBLIC DISCLOSURE.

Submission of any bid, proposal, or other document to the Purchasing Division constitutes your explicit consent to the subsequent public disclosure of the bid, proposal, or document. The Purchasing Division will disclose any document labeled "confidential," "proprietary," "trade secret," "private," or labeled with any other claim against public disclosure of the documents, to include any "trade secrets" as defined by West Virginia Code § 47-22-1 et seq. All submissions are subject to public disclosure without notice.

31. LICENSING: In accordance with West Virginia Code of State Rules § 148-1-6.1.e, Vendor must be licensed and in good standing in accordance with any and all state and local laws and requirements by any state or local agency of West Virginia, including, but not limited to, the West Virginia Secretary of State's Office, the West Virginia Tax Department, West Virginia Insurance Commission, or any other state agency or political subdivision. Obligations related to political subdivisions may include, but are not limited to, business licensing, business and occupation taxes, inspection compliance, permitting, etc. Upon request, the Vendor must provide all necessary releases to obtain information to enable the Purchasing Division Director or the Agency to verify that the Vendor is licensed and in good standing with the above entities. Vendor shall notify all subcontractors providing commodities or services related to this Contract that as subcontractors, they too are required to be licensed, in good standing, and up-to-date on all state and local obligations as described in this section.

32. ANTITRUST: In submitting a bid to, signing a contract with, or accepting an Award Document from any agency of the State of West Virginia, the Vendor agrees to convey, sell, assign, or transfer to the State of West Virginia all rights, title, and interest in and to all causes of action it may now or hereafter acquire under the antitrust laws of the United States and the State of West Virginia for price fixing and/or unreasonable restraints of trade relating to the particular commodities or services purchased or acquired by the State of West Virginia. Such assignment shall be made and become effective at the time the purchasing agency tenders the initial payment to Vendor.

33. VENDOR CERTIFICATIONS: By signing its bid or entering into this Contract, Vendor certifies (1) that its bid or offer was made without prior understanding, agreement, or connection with any corporation, firm, limited liability company, partnership, person or entity submitting a bid or offer for the same material, supplies, equipment or services; (2) that its bid or offer is in all respects fair and without collusion or fraud; (3) that this Contract is accepted or entered into without any prior understanding, agreement, or connection to any other entity that could be considered a violation of law; and (4) that it has reviewed this Solicitation in its entirety; understands the requirements, terms and conditions, and other information contained herein. Vendor's signature on its bid or offer also affirms that neither it nor its representatives have any interest, nor shall acquire any interest, direct or indirect, which would compromise the performance of its services hereunder. Any such interests shall be promptly presented in detail to the Agency. The individual signing this bid or offer on behalf of Vendor certifies that he or she is authorized by the Vendor to execute this bid or offer or any documents related thereto on

Vendor's behalf; that he or she is authorized to bind the Vendor in a contractual relationship; and that, to the best of his or her knowledge, the Vendor has properly registered with any State agency that may require registration.

34. VENDOR RELATIONSHIP: The relationship of the Vendor to the State shall be that of an independent contractor and no principal-agent relationship or employer-employee relationship is contemplated or created by this Contract. The Vendor as an independent contractor is solely liable for the acts and omissions of its employees and agents. Vendor shall be responsible for selecting, supervising, and compensating any and all individuals employed pursuant to the terms of this Solicitation and resulting contract. Neither the Vendor, nor any employees or subcontractors of the Vendor, shall be deemed to be employees of the State for any purpose whatsoever. Vendor shall be exclusively responsible for payment of employees and contractors

for all wages and salaries, taxes, withholding payments, penalties, fees, fringe benefits, professional liability insurance premiums, contributions to insurance and pension, or other deferred compensation plans, including but not limited to, Workers' Compensation and Social Security obligations, licensing fees, etc. and the filing of all necessary documents, forms, and returns pertinent to all of the foregoing. Vendor shall hold harmless the State, and shall provide the State and Agency with a defense against any and all claims including, but not limited to, the foregoing payments, withholdings, contributions, taxes, Social Security taxes, and employer income tax returns.

35. INDEMNIFICATION: The Vendor agrees to indemnify, defend, and hold harmless the State and the Agency, their officers, and employees from and against: (1) Any claims or losses for services rendered by any subcontractor, person, or firm performing or supplying services, materials, or supplies in connection with the performance of the Contract; (2) Any claims or losses resulting to any person or entity injured or damaged by the Vendor, its officers, employees, or subcontractors by the publication, translation, reproduction, delivery, performance, use, or disposition of any data used under the Contract in a manner not authorized by the Contract, or by Federal or State statutes or regulations; and (3) Any failure of the Vendor, its officers, employees, or subcontractors to observe State and Federal laws including, but not limited to, labor and wage and hour laws.

36. NO DEBT CERTIFICATION: In accordance with West Virginia Code §§ 5A-3-10a and 5-22-1(i), the State is prohibited from awarding a contract to any bidder that owes a debt to the State or a political subdivision of the State. By submitting a bid, or entering into a contract with the State, Vendor is affirming that (1) for construction contracts, the vendor is not in default on any monetary obligation owed to the state or a political subdivision of the state, and (2) for all other contracts, that neither vendor nor any related party owe a debt as defined above and that neither Vendor nor any related party are in employer default as defined in the statute cited above unless the debt or employer default is permitted under the statute.

37. CONFLICT OF INTEREST: Vendor, its officers or members or employees, shall not presently have or acquire an interest, direct or indirect, which would conflict with or compromise the performance of its obligations hereunder. Vendor shall periodically inquire of its officers, members and employees to ensure that a conflict of interest does not arise. Any conflict of interest discovered shall be promptly presented in detail to the Agency.

38. REPORTS: Vendor shall provide the Agency and/or the Purchasing Division with the following reports identified by a checked box below:

Such reports as the Agency and/or the Purchasing Division may request. Requested reports may include, but are not limited to, quantities purchased, agencies utilizing the contract, total contract expenditures by agency, etc.

Quarterly reports detailing the total quantity of purchases in units and dollars, along with a listing of purchases by agency. Quarterly reports should be delivered to the Purchasing Division via email at purchasing.division@wv.gov.

39. BACKGROUND CHECK: In accordance with W. Va. Code § 15-2D-3, the State reserves the right to prohibit a service provider's employees from accessing sensitive or critical information or to be present at the Capitol complex based upon results addressed from a criminal background check. Service providers should contact the West Virginia Division of Protective Services by phone at (304) 558-9911 for more information.

40. PREFERENCE FOR USE OF DOMESTIC STEEL PRODUCTS: Except when authorized by the Director of the Purchasing Division pursuant to W. Va. Code § 5A-3-56, no contractor may use or supply steel products for a State Contract Project other than those steel products made in the United States. A contractor who uses steel products in violation of this section may be subject to civil penalties pursuant to W. Va. Code § 5A-3-56. As used in this section:

a. "State Contract Project" means any erection or construction of, or any addition to, alteration of or other improvement to any building or structure, including, but not limited to, roads or highways, or the installation of any heating or cooling or ventilating plants or other equipment, or the supply of and materials for such projects, pursuant to a contract with the State of West Virginia for which bids were solicited on or after June 6, 2001.

b. "Steel Products" means products rolled, formed, shaped, drawn, extruded, forged, cast, fabricated or otherwise similarly processed, or processed by a combination of two or more or such operations, from steel made by the open hearth, basic oxygen, electric furnace, Bessemer or other steel making process. The Purchasing Division Director may, in writing, authorize the use of foreign steel products if:

c. The cost for each contract item used does not exceed one tenth of one percent (.1%) of the total contract cost or two thousand five hundred dollars (\$2,500.00), whichever is greater. For the purposes of this section, the cost is the value of the steel product as delivered to the project; or

d. The Director of the Purchasing Division determines that specified steel materials are not produced in the United States in sufficient quantity or otherwise are not reasonably available to meet contract requirements.

41. PREFERENCE FOR USE OF DOMESTIC ALUMINUM, GLASS, AND STEEL: In Accordance with W. Va. Code § 5-19-1 et seq., and W. Va. CSR § 148-10-1 et seq., for every contract or subcontract, subject to the limitations contained herein, for the construction, reconstruction, alteration, repair, improvement or maintenance of public works or for the purchase of any item of machinery or equipment to be used at sites of public works, only domestic aluminum, glass or steel products shall be supplied unless the spending officer determines, in writing, after the receipt of offers or bids, (1) that the cost of domestic aluminum, glass or steel products is unreasonable or inconsistent with the public interest of the State of West Virginia, (2) that domestic aluminum, glass or steel products are not produced in sufficient quantities to meet the contract requirements, or (3) the available domestic aluminum, glass, or steel do not meet the contract specifications. This provision only applies to public works contracts awarded in an amount more than fifty thousand dollars (\$50,000) or public works contracts that require more than ten thousand pounds of steel products.

The cost of domestic aluminum, glass, or steel products may be unreasonable if the cost is more

than twenty percent (20%) of the bid or offered price for foreign made aluminum, glass, or steel products. If the domestic aluminum, glass or steel products to be supplied or produced in a “substantial labor surplus area”, as defined by the United States Department of Labor, the cost of domestic aluminum, glass, or steel products may be unreasonable if the cost is more than thirty percent (30%) of the bid or offered price for foreign made aluminum, glass, or steel products. This preference shall be applied to an item of machinery or equipment, as indicated above, when the item is a single unit of equipment or machinery manufactured primarily of aluminum, glass or steel, is part of a public works contract and has the sole purpose or of being a permanent part of a single public works project. This provision does not apply to equipment or machinery purchased by a spending unit for use by that spending unit and not as part of a single public works project.

All bids and offers including domestic aluminum, glass or steel products that exceed bid or offer prices including foreign aluminum, glass or steel products after application of the preferences provided in this provision may be reduced to a price equal to or lower than the lowest bid or offer price for foreign aluminum, glass or steel products plus the applicable preference. If the reduced bid or offer prices are made in writing and supersede the prior bid or offer prices, all bids or offers, including the reduced bid or offer prices, will be reevaluated in accordance with this rule.

42. PROHIBITION AGAINST USED OR REFURBISHED: Unless expressly permitted in the solicitation published by the State, Vendor must provide new, unused commodities, and is prohibited from supplying used or refurbished commodities, in fulfilling its responsibilities under this Contract.

43. VOID CONTRACT CLAUSES – This Contract is subject to the provisions of West Virginia Code § 5A-3-62, which automatically voids certain contract clauses that violate State law.

DESIGNATED CONTACT: Vendor appoints the individual identified in this Section as the Contract Administrator and the initial point of contact for matters relating to this Contract.

Rita Marie Lomoglio

(Name, Title)

Rita Marie Lomoglio, Government Account Manager

(Printed Name and Title)

21439 N 2nd Ave. Phoenix, AZ 85027

(Address)

(602) 863-2655 x251 / (623) 879-7341

(Phone Number) / (Fax Number)

gov@gruber.com

(E-mail address)

CERTIFICATION AND SIGNATURE: By signing below, or submitting documentation through wvOASIS, I certify that I have reviewed this Solicitation in its entirety; that I understand the requirements, terms and conditions, and other information contained herein; that this bid, offer or proposal constitutes an offer to the State that cannot be unilaterally withdrawn; that the product or service proposed meets the mandatory requirements contained in the Solicitation for that product or service, unless otherwise stated herein; that the Vendor accepts the terms and conditions contained in the Solicitation, unless otherwise stated herein; that I am submitting this bid, offer or proposal for review and consideration; that I am authorized by the vendor to execute and submit this bid, offer, or proposal, or any documents related thereto on vendor's behalf; that I am authorized to bind the vendor in a contractual relationship; and that to the best of my knowledge, the vendor has properly registered with any State agency that may require registration.

By signing below, I further certify that I understand this Contract is subject to the provisions of West Virginia Code § 5A-3-62, which automatically voids certain contract clauses that violate State law.

Gruber Technical Inc DBA Gruber Power Services

(Company)

Rita Marie Lomoglio

(Authorized Signature) (Representative Name, Title)

Rita Marie Lomoglio / Government Account Manager

(Printed Name and Title of Authorized Representative)

5/26/2022

(Date)

(602) 863-2655 x251 / (623) 879-7341

(Phone Number) (Fax Number)

Revised 04/01/2022

REQUEST FOR QUOTATION
Open End Contract for UPS Batteries

SPECIFICATIONS

1. **PURPOSE AND SCOPE:** The West Virginia Department of Transportation is soliciting bids to establish an open end contract to purchase UPS Batteries.
2. **DEFINITIONS:** The terms listed below shall have the meanings assigned to them below. Additional definitions can be found in section 2 of the General Terms and Conditions.
 - 2.1. **“Contract Item”** means the list of items identified in Section 3.1 below and on the Pricing Pages.
 - 2.2. **“Pricing Pages”** means the schedule of prices, estimated order quantity, and totals contained in wvOASIS or attached hereto as Exhibit A, and used to evaluate the Solicitation responses.
 - 2.3. **“Solicitation”** means the official notice of an opportunity to supply the State with goods or services that is published by the Purchasing Division.
 - 2.4. **“UPS”** means uninterruptible power supply.
3. **GENERAL REQUIREMENTS:**
 - 3.1. **Mandatory Contract Item Requirements:** The Vendor shall provide Agency with the Contract Items listed below and the items must meet or exceed the mandatory requirements listed.
 - 3.1.1. Contract Item #1: UPS Battery – 12V 8AH AGM
 - 3.2. **Alternate bids that are equal to, meet, or exceed the specifications and requirements listed are invited. In order to receive full consideration, such alternate bids must be accompanied by sufficient descriptive literature and/or samples to clearly identify the offer and allow for a complete evaluation.**

The use of brand name or equal specifications is for describing the minimum standard of quality, technical performance and installation characteristics required and are not intended to limit or restrict competition.
4. **CONTRACT AWARD:**
 - 4.1. **Contract Award:** The Contract is intended to provide the Agency with a purchase price on all Contract Items. The Contract shall be awarded to the Vendor that provides the Contract Items meeting the required specifications for the lowest overall total cost as shown on the Pricing Pages.

REQUEST FOR QUOTATION
Open End Contract for UPS Batteries

4.2. Pricing Pages: Vendor should complete the Pricing Pages by completing the cost table included as Exhibit A. Vendor should complete the Pricing Pages in their entirety as failure to do so may result in Vendor's bids being disqualified.

The Pricing Pages contain a list of the Contract Items and estimated purchase volume. The estimated purchase volume for each item represents the approximate volume of anticipated purchases only. No future use of the Contract or any individual item is guaranteed or implied.

Vendor should type or electronically enter the information into the Pricing Page to prevent errors in the evaluation.

5. ORDERING AND PAYMENT:

5.1. Ordering: Vendor shall accept orders through wvOASIS, regular mail, facsimile, e-mail, or any other written form of communication. Vendor may, but is not required to, accept on-line orders through a secure internet ordering portal/website. If Vendor has the ability to accept on-line orders, it should include in its response a brief description of how Agencies may utilize the on-line ordering system. Vendor shall ensure that its on-line ordering system is properly secured prior to processing Agency orders on-line.

5.2. Payment: Vendor shall accept payment in accordance with the payment procedures of the State of West Virginia.

6. DELIVERY AND RETURN:

6.1. Shipment and Delivery: Vendor shall deliver the Contract Items within ten (10) working days after being awarded this Contract and receiving a purchase order or notice to proceed.

6.2. Late Delivery: The Agency placing the order under this Contract must be notified in writing if the shipment of the Contract Items will be delayed for any reason. Any delay in delivery that could cause harm to an Agency will be grounds for cancellation of the Contract, and/or obtaining the Contract Items from a third party.

Any Agency seeking to obtain the Contract Items from a third party under this provision must first obtain approval of the Purchasing Division.

6.3. Delivery Payment/Risk of Loss: Vendor shall deliver the Contract Items F.O.B. destination to the Agency's location. Vendor shall include the cost of order delivery charges in its bid pricing/discount and is not permitted to charge the Agency separately for such delivery.

REQUEST FOR QUOTATION
Open End Contract for UPS Batteries

6.4. Return of Unacceptable Items: If the Agency deems the Contract Items to be unacceptable, the Contract Items shall be returned to Vendor at Vendor's expense and with no restocking charge. Vendor shall either make arrangements for the return within five (5) days of being notified that item(s) are unacceptable or permit the Agency to arrange for the return and reimburse Agency for delivery expenses. If the original packaging cannot be utilized for the return, Vendor will supply the Agency with appropriate return packaging upon request. All returns of unacceptable items shall be F.O.B. the Agency's location. The returned product shall either be replaced, or the Agency shall receive a full credit or refund for the purchase price, at the Agency's discretion.

6.5. Return Due to Agency Error: Items ordered in error by the Agency will be returned for credit within 30 days of receipt, F.O.B. Vendor's location. Vendor shall not charge a restocking fee if returned products are in a resalable condition. Items shall be deemed to be in a resalable condition if they are unused and in the original packaging. Any restocking fee for items not in a resalable condition shall be the lower of the Vendor's customary restocking fee or 5% of the total invoiced value of the returned items.

7. VENDOR DEFAULT:

7.1. The following shall be considered a vendor default under this Contract.

- 7.1.1.** Failure to provide Contract Items in accordance with the requirements contained herein.
- 7.1.2.** Failure to comply with other specifications and requirements contained herein.
- 7.1.3.** Failure to comply with any laws, rules, and ordinances applicable to the Contract Services provided under this Contract.
- 7.1.4.** Failure to remedy deficient performance upon request.

7.2. The following remedies shall be available to Agency upon default.

- 7.2.1.** Immediate cancellation of the Contract.
- 7.2.2.** Immediate cancellation of one or more release orders issued under this Contract.
- 7.2.3.** Any other remedies available in law or equity.

8. MISCELLANEOUS:

8.1. No Substitutions: Vendor shall supply only Contract Items submitted in response to the Solicitation unless a contract modification is approved in accordance with the provisions contained in this Contract.

REQUEST FOR QUOTATION
Open End Contract for UPS Batteries

8.2. Vendor Supply: Vendor must carry sufficient inventory of the Contract Items being offered to fulfill its obligations under this Contract. By signing its bid, Vendor certifies that it can supply the Contract Items contained in its bid response.

8.3. Contract Manager: During its performance of this Contract, Vendor must designate and maintain a primary contract manager responsible for overseeing Vendor's responsibilities under this Contract. The Contract manager must be available during normal business hours to address any customer service or other issues related to this Contract. Vendor should list its Contract manager and his or her contact information below.

Contract Manager: Rita Marie Lomoglio

Telephone Number: (602) 863-2655 x251

Fax Number: (623) 879-7341

Email Address: gov@gruber.com

EXHIBIT A - PRICING PAGE

Open End Contract Pricing for UPS Batteries

LOCATION: BUILDING 5, ROOM A-720, CHARLESTON, WV 25305

Contract Item Number	Description	Quantity*	Unit Cost	Extended Cost
1	12V *AH AGM Battery	300	\$ 23.45	\$7,035.00
				\$0.00

* Quantity listed is an estimated purchase volume.

The estimated purchase volume represents the approximate volume of anticipated purchases only.

No future use of the Contract or any individual item is guaranteed or implied.



Vendor Signature



**State of West Virginia
Agency Request for Quote
Info Technology**

Proc Folder: 1041355		Reason for Modification:	
Doc Description: ADDENDUM 1: UPS Batteries (81220107)		ADDENDUM 1	
Proc Type: Agency Master Agreement			
Date Issued	Solicitation Closes	Solicitation No	Version
2022-05-24	2022-05-31 14:30	ARFQ 0803 DOT2200000034	2

BID RECEIVING LOCATION

BUDGET & PROCUREMENT
 DIVISION OF HIGHWAYS
 BLDG 5, RM A-260
 1900 KANAWHA BLVD E
 CHARLESTON WV 25305
 US

VENDOR

Vendor Customer Code: VS0000011412
Vendor Name : Gruber Technical Inc DBA Gruber Power Services
Address :
Street : 21439 N. 2nd Ave
City : Phoenix
State : AZ **Country :** USA **Zip :** 85027
Principal Contact : Rita Marie Lomoglio
Vendor Contact Phone: (602) 863-2655 **Extension:** 251

FOR INFORMATION CONTACT THE BUYER

Dusty J Smith
 304-414-2063
 dusty.j.smith@wv.gov

Vendor Signature X *Rita Marie Lomoglio* **FEIN#** 86-1001733 **DATE** 5/26/2022

All offers subject to all terms and conditions contained in this solicitation

ADDITIONAL INFORMATION

ADDENDUM 1 IS ISSUED
TO RESPOND TO THE VENODR QUESTIONS
NO OTHER CHANGES

INVOICE TO		SHIP TO	
DEPT. OF TRANSPORTATION 1900 KANAWHA BLVD E, BLD. 5 RM-720		DEPT. OF TRANSPORTATION 1900 KANAWHA BLVD E, BLD. 5 RM-720	
CHARLESTON	WV	CHARLESTON	WV
US		US	

Line	Comm Ln Desc	Qty	Unit Issue	Unit Price	Total Price
1	UPS Battery 12V 8AH AGM	0.00000	EA		

Comm Code	Manufacturer	Specification	Model #
26111700			

Extended Description:
UPS Battery 12V 8AH AGM

SCHEDULE OF EVENTS

<u>Line</u>	<u>Event</u>	<u>Event Date</u>
1	TECHNICAL QUESTIONS DUE AT 10AM	2022-05-23

SOLICITATION NUMBER:
Addendum Number:

The purpose of this addendum is to modify the solicitation identified as (“Solicitation”) to reflect the change(s) identified and described below.

Applicable Addendum Category:

- Modify bid opening date and time
- Modify specifications of product or service being sought
- Attachment of vendor questions and responses
- Attachment of pre-bid sign-in sheet
- Correction of error
- Other

Description of Modification to Solicitation:

Additional Documentation: Documentation related to this Addendum (if any) has been included herewith as Attachment A and is specifically incorporated herein by reference.

Terms and Conditions:

1. All provisions of the Solicitation and other addenda not modified herein shall remain in full force and effect.
2. Vendor should acknowledge receipt of all addenda issued for this Solicitation by completing an Addendum Acknowledgment, a copy of which is included herewith. Failure to acknowledge addenda may result in bid disqualification. The addendum acknowledgement should be submitted with the bid to expedite document processing.

ATTACHMENT A

Please route to → Dusty Smith

Customer	West Virginia, State of-WV Charleston			PO #	Pending	Quote Date	05/26/2022
Dept		Voice #	1-304-558-9911	Quote #	22May0924		
Address	1900 Kanawha Blvd E			Cell #		Extension	
Mail Stop		Suite		Tech Cont		Fax #	
City	Charleston	State	WV	Zip	25305-1209	Email	terry.w.finney@cappd.wvsp.gov

Battery Quote Section

Qty	Brand	Part Number	Description	Volts	A/H	Post Style	Weight	Unit Cost	Total	
300	GPS	58AGPS-12-9-F2	UPS Battery	12 V	9 AH		5 lbs	\$ 23.45	\$ 7,035.00	
							Total Weight	1620 lbs	Subtotal	\$ 7,035.00
Quote Number	22May0924			Prepared by:	Bryan Moot x334			Shipping & Handling	\$ 652.91	
Warranty	<input checked="" type="checkbox"/>			Email	mo9@gruber.com			Tax	\$ 0.00	
Extended warranties are available. Please review our "Battery Care and Maintenance" section to improve battery life.								Grand Total	\$ 7,687.91	

Notes or Special Instructions	Terminal
Tax will be applied at time of sale unless tax exempt documentation is provided At time of quote, Gruber's stock of these batteries exceeds three thousand units.	

Critical Power Products	Critical Power Repair Services	Critical Power Batteries
		

Sales of all brands of new and refurbished

Nationwide service on all brands of UPS

The source of the leading UPS battery

Prepared by:	Phone Number	Email
Bryan Moot x334	800-658-5883	mo9@gruber.com

ARFQ-0803-DOT2200000034

UPS Batteries (81220107) Technical Questions

Question 1 Can you provide the required dimensions for the batteries?

Response 1 Dimensions: 6"L x 2.5"W x 3.75" H
Part/Catalog#: BP12-8 or equal

Question 2 Appreciate if you could provide model number of the UPS to provide
accurate product and best pricing for this opportunity

Response 2 Part/Catalog#: BP12-8 or equal

ADDENDUM ACKNOWLEDGEMENT FORM
SOLICITATION NO.: _____

Instructions: Please acknowledge receipt of all addenda issued with this solicitation by completing this addendum acknowledgment form. Check the box next to each addendum received and sign below. Failure to acknowledge addenda may result in bid disqualification.

Acknowledgment: I hereby acknowledge receipt of the following addenda and have made the necessary revisions to my proposal, plans and/or specification, etc.

Addendum Numbers Received:

(Check the box next to each addendum received)

- | | |
|--|--|
| <input checked="" type="checkbox"/> Addendum No. 1 | <input type="checkbox"/> Addendum No. 6 |
| <input type="checkbox"/> Addendum No. 2 | <input type="checkbox"/> Addendum No. 7 |
| <input type="checkbox"/> Addendum No. 3 | <input type="checkbox"/> Addendum No. 8 |
| <input type="checkbox"/> Addendum No. 4 | <input type="checkbox"/> Addendum No. 9 |
| <input type="checkbox"/> Addendum No. 5 | <input type="checkbox"/> Addendum No. 10 |

I understand that failure to confirm the receipt of addenda may be cause for rejection of this bid. I further understand that any verbal representation made or assumed to be made during any oral discussion held between Vendor's representatives and any state personnel is not binding. Only the information issued in writing and added to the specifications by an official addendum is binding.

Gruber Power Services

Company



Authorized Signature

5/26/2022

Date

NOTE: This addendum acknowledgment should be submitted with the bid to expedite document processing.

Revised 6/8/2012

58AGPS-12-9-F2 (12V9.0AH)

Specification

Nominal Voltage	12V	
Nominal Capacity(20HR)	9.0AH	
Dimensions	Length	151±2mm (5.95 inches)
	Width	65±1mm (2.56 inches)
	Container Height	93.5±1mm (3.68 inches)
	Total Height (with Terminal)	99±1mm (3.90 inches)
Approx Weight	Approx 2.45 kg (5.40lbs)	
Terminal	T2	
Container Material	ABS	
Rated Capacity	9.00 AH/0.450A	(20hr , 1.80V/cell,25°C/77°F)
	8.40 AH/0.840A	(10hr, 1.80V/cell,25°C/77°F)
	7.55 AH/1.51A	(5hr, 1.75V/cell,25°C/77°F)
	6.72 AH/2.24A	(3hr, 1.75V/cell,25°C/77°F)
	5.62 AH/5.62A	(1hr, 1.60V/cell,25°C/77°F)
Max. Discharge Current	135A (5s)	
Internal Resistance	Approx 17mΩ	
Operating Temp.Range	Discharge : -15~50°C (5~122°F)	
	Charge : 0~40°C (32~104°F)	
	Storage : -15~40°C (5~104°F)	
Nominal Operating Temp. Range	25±3°C (77±5°F)	
Cycle Use	Initial Charging Current less than 2.7A.Voltage	
	14.4V~15.0V at 25°C(77°F)Temp. Coefficient -30mV/°C	
Standby Use	No limit on Initial Charging Current Voltage	
	13.5V~13.8V at 25°C(77°F)Temp. Coefficient -20mV/°C	
Capacity affected by Temperature	40°C (104°F)	103%
	25°C (77°F)	100%
	0°C (32°F)	86%
Self Discharge	GRUBER 58AGPS series batteries may be stored for up to 6 months at 25°C(77°F) and then a freshening charge is required. For higher temperatures the time interval will be shorter.	



Applications

- ◆ All purpose
- ◆ Uninterruptable Power Supply (UPS)
- ◆ Electric Power System (EPS)
- ◆ Emergency backup power supply
- ◆ Emergency light
- ◆ Railway signal
- ◆ Aircraft signal
- ◆ Alarm and security system
- ◆ Electronic apparatus and equipment
- ◆ Communication power supply
- ◆ DC power supply
- ◆ Auto control system

Constant Current Discharge (Amperes) at 25 °C (77°F)

F.V/Time	5min	10min	15min	20min	30min	45min	1h	2h	3h	4h	5h	6h	8h	10h	20h
1.85V/cell	20.8	14.7	12.4	10.5	7.85	5.82	4.66	2.77	2.06	1.67	1.41	1.22	0.965	0.797	0.439
1.80V/cell	24.8	16.9	13.9	11.5	8.59	6.28	5.01	2.96	2.19	1.77	1.48	1.28	1.018	0.840	0.450
1.75V/cell	27.6	18.4	14.9	12.3	8.95	6.51	5.19	3.05	2.24	1.80	1.51	1.30	1.036	0.853	0.460
1.70V/cell	30.2	19.9	15.7	12.8	9.29	6.73	5.34	3.13	2.30	1.84	1.54	1.32	1.050	0.864	0.465
1.65V/cell	32.7	21.0	16.3	13.2	9.59	6.95	5.51	3.19	2.35	1.86	1.57	1.34	1.062	0.874	0.469
1.60V/cell	34.5	21.8	16.8	13.6	9.87	7.12	5.62	3.26	2.38	1.91	1.59	1.37	1.073	0.881	0.472

Constant Power Discharge (Watts/cell) at 25 °C (77°F)

F.V/Time	5min	10min	15min	20min	30min	45min	1h	2h	3h	4h	5h	6h	8h	10h	20h
1.85V/cell	39.1	28.0	23.7	20.3	15.4	11.4	9.18	5.48	4.11	3.34	2.83	2.46	1.94	1.61	0.888
1.80V/cell	46.2	32.0	26.4	22.3	16.7	12.3	9.83	5.86	4.34	3.52	2.96	2.57	2.04	1.68	0.905
1.75V/cell	51.2	34.6	28.3	23.5	17.3	12.7	10.2	6.00	4.43	3.56	3.00	2.59	2.06	1.70	0.920
1.70V/cell	55.0	36.8	29.3	24.2	17.8	13.0	10.4	6.11	4.51	3.61	3.03	2.63	2.08	1.72	0.923
1.65V/cell	58.8	38.3	30.1	24.8	18.2	13.2	10.6	6.17	4.56	3.64	3.06	2.64	2.09	1.73	0.925
1.60V/cell	60.6	38.9	30.6	25.0	18.4	13.4	10.7	6.27	4.60	3.68	3.09	2.67	2.10	1.74	0.928

Dimensions

T2 Terminal

Unit: mm [inches]

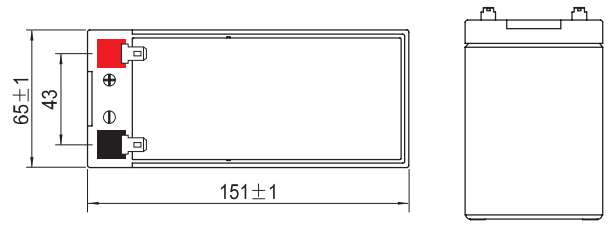
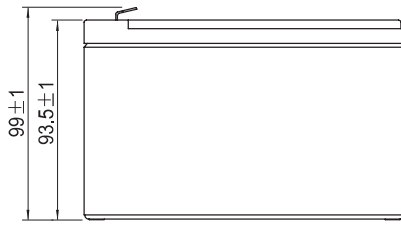
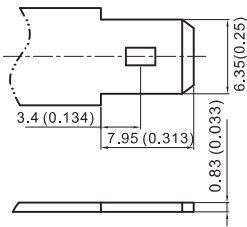

Discharge Characteristics

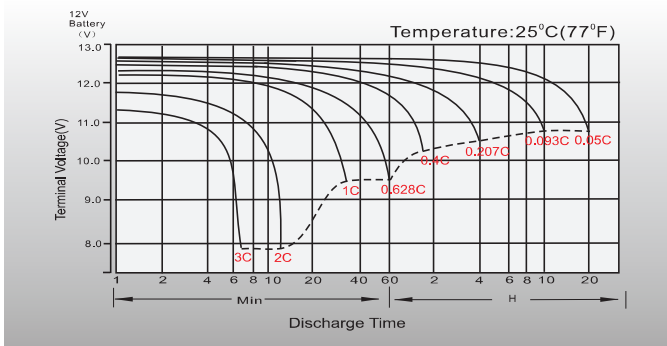

Float Charging Characteristics

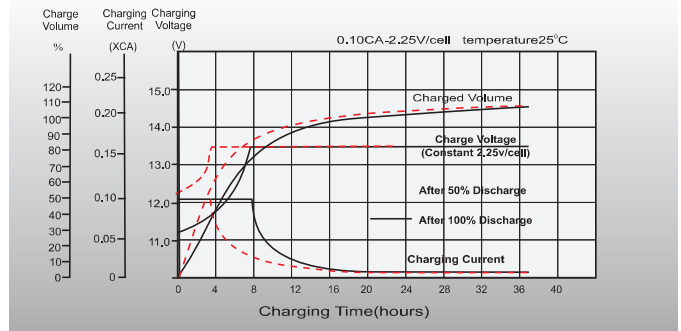

Temperature Effects in Relation to Battery Capacity

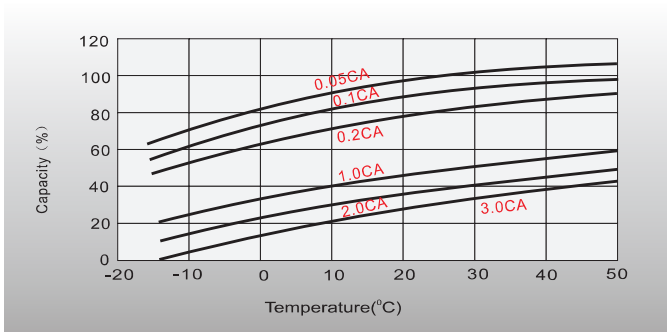

Effect of Temperature on Long Term Float Life

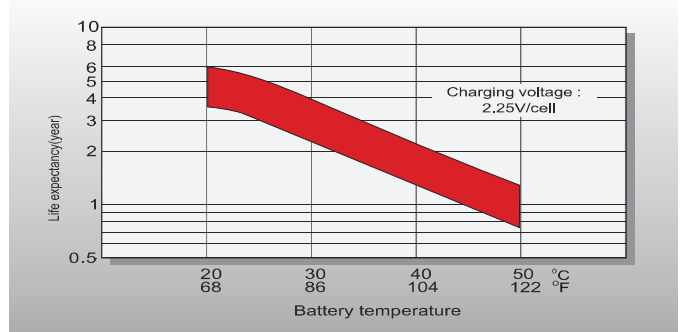

Cycle Life in Relation to Depth of Discharge

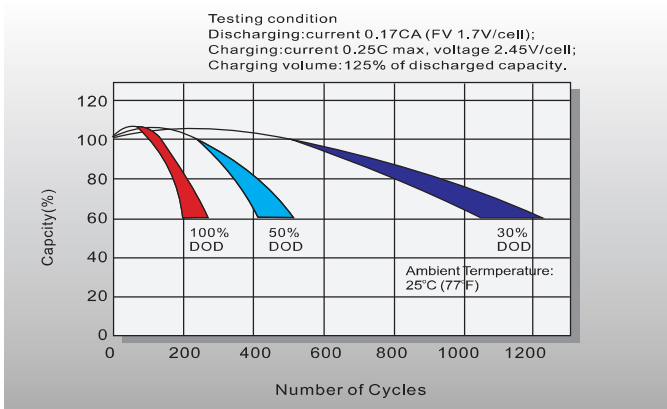

Self Discharge Characteristics

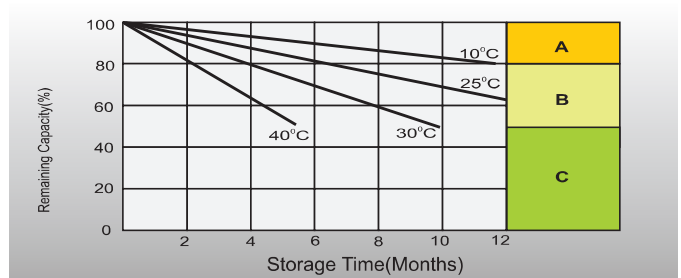

- A** No supplementary charge required (Carry out supplementary charge before use if 100% capacity is required.)
- B** Supplementary charge required before use. Optional charging way as below:
 1. Charged for above 3 days at limited current 0.25CA and constant voltage 2.25V/cell.
 2. Charged for above 20 hours at limited current 0.25CA and constant voltage 2.45V/cell.
 3. Charged for 8-10 hours at limited current 0.05CA.
- C** Supplementary charge may often fail to recover the capacity. The battery should never be left standing till this is reached.

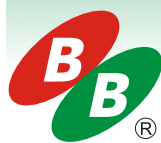

VRLA Rechargeable Battery

BP8-12

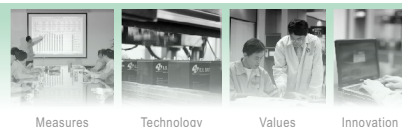

FEATURES

- Maintenance Free (topping up not needed)
- Non-spillable (no free electrolyte)
- Low Self Discharge, less than 3% per month
- both Vertical & Horizontal installations

APPLICATIONS

- UPS
- Laboratory Equipment
- Toy-Cars
- Power Packs
- Fishing Lights



SPECIFICATIONS

Nominal Voltage	12 V
Nominal Capacity	8.0Ah @ 20 hour rate F.V.(1.75V/cell)
Approx. Weight	2650g(5.84lbs.)
Terminals	T2 (Faston Tab 250) T1 is optional
Internal Resistance	≤25mΩ (Fully Charged)
Max. Discharge Current	120 A (5 sec.)
Max. Charge Current	2.4 A
Operating Temperature Range	Charge: 0°C~40°C(32°F~104°F) Discharge: -20°C~50°C(-4°F~122°F) Storage: -20°C~40°C(-4°F~104°F)
Container Material	Standard: ABS (UL94 HB) BP8-12 Optional: Flame Retardant ABS(UL94 V-0) BP8-12FR

 MH19884

 C4M20310-2474-E-16

- IEC 61056-1
- JIS C 8702-1
- GB/T 19639.1

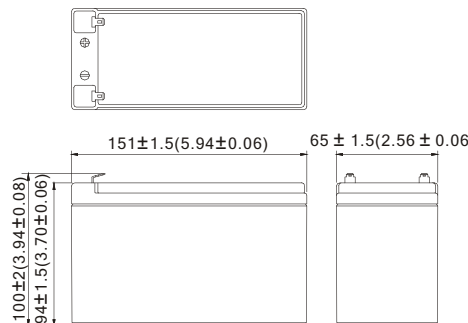
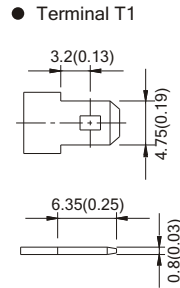
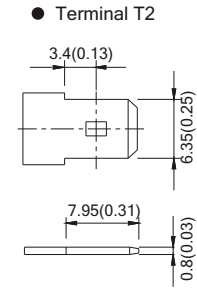
DIMENSION(mm/inch)	OUTER DIMENSIONS	TERMINAL TYPE
<ul style="list-style-type: none"> ■ Length 151±1.5 (5.94±0.06) ■ Width 65±1.5 (2.56±0.06) ■ Container Height 94±1.5 (3.70±0.06) ■ Total Height 100±2.0 (3.94±0.08) 		<ul style="list-style-type: none"> ● Terminal T1  ● Terminal T2 

Constant power discharge characteristics at 25 °C/77 °F Unit: W

F.V. (V/cell) \ Discharge Time	5 Min	10 Min	15 Min	30 Min	1 Hr	3 Hr	5 Hr	10 Hr	20 Hr
1.80V	289	213	171	101.5	58.2	23.3	16.08	8.99	4.73
1.75V	335	231	178	105.4	60.0	23.8	16.32	9.12	4.80
1.70V	356	239	184	107.8	61.0	24.0	16.41	9.17	4.82
1.65V	372	245	188	109.3	61.8	24.2	16.47	9.19	4.84
1.60V	384	250	192	110.4	62.4	24.3	16.52	9.19	4.84

Constant current discharge characteristics at 25 °C/77 °F Unit: A

F.V. (V/cell) \ Discharge Time	5 Min	10 Min	15 Min	30 Min	1 Hr	3 Hr	5 Hr	10 Hr	20 Hr
1.80V	26.1	18.7	14.8	8.60	4.89	1.94	1.340	0.749	0.394
1.75V	30.7	20.3	15.5	8.93	5.04	1.98	1.360	0.760	0.400
1.70V	32.6	21.0	16.0	9.14	5.13	2.00	1.367	0.764	0.402
1.65V	34.1	21.5	16.4	9.26	5.19	2.01	1.372	0.766	0.403
1.60V	35.2	22.0	16.7	9.36	5.24	2.03	1.376	0.766	0.403

All data and artworks shall be changed without prior notice, BB reserves the right to explain and update the information contained hereinto.