



Department of Administration
 Purchasing Division
 2019 Washington Street East
 Post Office Box 50130
 Charleston, WV 25305-0130

**State of West Virginia
 Solicitation Response**

Proc Folder: 1061135
Solicitation Description: ADDENDUM 1 : Fabrication of a spreader rack for District 9
Proc Type: Agency Purchase Order

Solicitation Closes	Solicitation Response	Version
2022-07-22 14:30	SR 0803 ESR07152200000000220	1

VENDOR
 VS0000022174
 KODIAK MANUFACTURING INC

Solicitation Number: ARFQ 0803 DOT2300000003
Total Bid: 30294.38000000000101863406598 **Response Date:** 2022-07-15 **Response Time:** 13:59:56
Comments:

FOR INFORMATION CONTACT THE BUYER

Dusty J Smith
 304-414-6859
 dusty.j.smith@wv.gov

Vendor Signature X **FEIN#** **DATE**

All offers subject to all terms and conditions contained in this solicitation

Line	Comm Ln Desc	Qty	Unit Issue	Unit Price	Ln Total Or Contract Amount
1	(14 each) W10x22x11'5"	3516.3300	LB	1.490000	5239.33

Comm Code	Manufacturer	Specification	Model #
30101704			

Commodity Line Comments: does not include shipping

Extended Description:

(14 each) W10x22x11'5"

Line	Comm Ln Desc	Qty	Unit Issue	Unit Price	Ln Total Or Contract Amount
2	(8 each) Angle, 3x5x1/4x7'5"	391.60000	LB	2.050000	802.78

Comm Code	Manufacturer	Specification	Model #
30101504			

Commodity Line Comments: does not include shipping

Extended Description:

(8 each) Angle, 3x5x1/4x7'5"

Line	Comm Ln Desc	Qty	Unit Issue	Unit Price	Ln Total Or Contract Amount
3	(4 each) HSS 6X6X1/4"X12'10"	976.36000	LB	1.650000	1610.99

Comm Code	Manufacturer	Specification	Model #
30101704			

Commodity Line Comments: does not include shipping

Extended Description:

(4 each) HSS 6X6X1/4"X12'10"

Line	Comm Ln Desc	Qty	Unit Issue	Unit Price	Ln Total Or Contract Amount
4	(12 each) HSS 6X6X1/4X12'10"	2929.0800	LB	1.650000	4832.98

Comm Code	Manufacturer	Specification	Model #
30101704			

Commodity Line Comments: does not include shipping

Extended Description:

(12 each) HSS 6X6X1/4X12'10"

Line	Comm Ln Desc	Qty	Unit Issue	Unit Price	Ln Total Or Contract Amount
5	(16 each) PL 3/4"X16"X16"	1161.6000	LB	1.050000	1219.68

Comm Code	Manufacturer	Specification	Model #
30264000			

Commodity Line Comments: does not include shipping

Extended Description:

(16 each) PL 3/4"X16"X16"

Line	Comm Ln Desc	Qty	Unit Issue	Unit Price	Ln Total Or Contract Amount
6	(44 each) PL 3/8"X4"X8"	112.35000	LB	1.840000	206.72

Comm Code	Manufacturer	Specification	Model #
30264000			

Commodity Line Comments: does not include shipping

Extended Description:

(44 each) PL 3/8"X4"X8"

Line	Comm Ln Desc	Qty	Unit Issue	Unit Price	Ln Total Or Contract Amount
7	(16 each) PL 1/4"X6"X6"	20.40000	LB	2.750000	56.10

Comm Code	Manufacturer	Specification	Model #
30264000			

Commodity Line Comments: does not include shipping

Extended Description:

(16 each) PL 1/4"X6"X6"

Line	Comm Ln Desc	Qty	Unit Issue	Unit Price	Ln Total Or Contract Amount
8	(5 each) Expanded Metal, 1/4"x11"x8' (3/4"x#9)	184.00000	LB	4.230000	778.32

Comm Code	Manufacturer	Specification	Model #
30264000			

Commodity Line Comments: does not include shipping

Extended Description:

(5 each) Expanded Metal, 1/4"x11"x8' (3/4"x#9)

Line	Comm Ln Desc	Qty	Unit Issue	Unit Price	Ln Total Or Contract Amount
9	(5 each) Angle, 3"x3"x1/4"x20'	940.00000	LB	0.580000	545.20

Comm Code	Manufacturer	Specification	Model #
30101504			

Commodity Line Comments: does not include shipping

Extended Description:

(5 each) Angle, 3"x3"x1/4"x20'

Line	Comm Ln Desc	Qty	Unit Issue	Unit Price	Ln Total Or Contract Amount
10	(10 each) Angle, 1 1/2"x1 1/2"x20'	468.00000	LB	1.960000	917.28

Comm Code	Manufacturer	Specification	Model #
30101504			

Commodity Line Comments: does not include shipping

Extended Description:

(10 each) Angle, 1 1/2"x1 1/2"x20'

Line	Comm Ln Desc	Qty	Unit Issue	Unit Price	Ln Total Or Contract Amount
11	All Fasteners Required	1.00000	LS	1980.000000	1980.00

Comm Code	Manufacturer	Specification	Model #
31161600			

Commodity Line Comments: does not include shipping

Extended Description:

All Fasteners Required

Line	Comm Ln Desc	Qty	Unit Issue	Unit Price	Ln Total Or Contract Amount
12	Fabrication and Paint	0.00000			12105.00

Comm Code	Manufacturer	Specification	Model #
86131502			

Commodity Line Comments:

Extended Description:

Fabrication and Paint



**State of West Virginia
Agency Request for Quote
Highways**

Proc Folder: 1061135		Reason for Modification:	
Doc Description: ADDENDUM 1 : Fabrication of a spreader rack for District 9		ADDENDUM 1 : TO ATTACH THE DRAWING OF THE SHED	
Proc Type: Agency Purchase Order			
Date Issued	Solicitation Closes	Solicitation No	Version
2022-07-08	2022-07-22 14:30	ARFQ 0803 DOT2300000003	2

BID RECEIVING LOCATION

BUDGET & PROCUREMENT
DIVISION OF HIGHWAYS
BLDG 5, RM A-260
1900 KANAWHA BLVD E
CHARLESTON WV 25305
US

VENDOR

Vendor Customer Code:
Vendor Name :
Address :
Street :
City :
State : **Country :** **Zip :**
Principal Contact :
Vendor Contact Phone: **Extension:**

FOR INFORMATION CONTACT THE BUYER

Dusty J Smith
304-414-6859
dusty.j.smith@wv.gov

Vendor Signature X **FEIN#** **DATE**

All offers subject to all terms and conditions contained in this solicitation

ADDITIONAL INFORMATION

ADDENDUM 1 : IS ISSUED TO ATTACH THE DRAWING OF THE SHED

INVOICE TO		SHIP TO	
DIVISION OF HIGHWAYS DISTRICT NINE 146 STONEHOUSE RD LEWISBURG WV US		DIVISION OF HIGHWAYS DISTRICT NINE SUMMERS COUNTY HEADQUARTERS 20414 STATE RT 12 HINTON WV US	

Line	Comm Ln Desc	Qty	Unit Issue	Unit Price	Total Price
1	(14 each) W10x22x11'5"	3516.33000	LB		

Comm Code	Manufacturer	Specification	Model #
30101704			

Extended Description:
(14 each) W10x22x11'5"

INVOICE TO		SHIP TO	
DIVISION OF HIGHWAYS DISTRICT NINE 146 STONEHOUSE RD LEWISBURG WV US		DIVISION OF HIGHWAYS DISTRICT NINE SUMMERS COUNTY HEADQUARTERS 20414 STATE RT 12 HINTON WV US	

Line	Comm Ln Desc	Qty	Unit Issue	Unit Price	Total Price
2	(8 each) Angle, 3x5x1/4x7'5"	391.60000	LB		

Comm Code	Manufacturer	Specification	Model #
30101504			

Extended Description:
(8 each) Angle, 3x5x1/4x7'5"

INVOICE TO		SHIP TO	
DIVISION OF HIGHWAYS DISTRICT NINE 146 STONEHOUSE RD LEWISBURG WV US		DIVISION OF HIGHWAYS DISTRICT NINE SUMMERS COUNTY HEADQUARTERS 20414 STATE RT 12 HINTON WV US	

Line	Comm Ln Desc	Qty	Unit Issue	Unit Price	Total Price
3	(4 each) HSS 6X6X1/4"X12'10"	976.36000	LB		

Comm Code	Manufacturer	Specification	Model #
30101704			

Extended Description:
(4 each) HSS 6X6X1/4"X12'10"

INVOICE TO		SHIP TO	
DIVISION OF HIGHWAYS DISTRICT NINE 146 STONEHOUSE RD LEWISBURG WV US		DIVISION OF HIGHWAYS DISTRICT NINE SUMMERS COUNTY HEADQUARTERS 20414 STATE RT 12 HINTON WV US	

Line	Comm Ln Desc	Qty	Unit Issue	Unit Price	Total Price
4	(12 each) HSS 6X6X1/4X12'10"	2929.08000	LB		

Comm Code	Manufacturer	Specification	Model #
30101704			

Extended Description:
(12 each) HSS 6X6X1/4X12'10"

INVOICE TO		SHIP TO	
DIVISION OF HIGHWAYS DISTRICT NINE 146 STONEHOUSE RD LEWISBURG WV US		DIVISION OF HIGHWAYS DISTRICT NINE SUMMERS COUNTY HEADQUARTERS 20414 STATE RT 12 HINTON WV US	

Line	Comm Ln Desc	Qty	Unit Issue	Unit Price	Total Price
5	(16 each) PL 3/4"X16"X16"	1161.60000	LB		

Comm Code	Manufacturer	Specification	Model #
30264000			

Extended Description:
(16 each) PL 3/4"X16"X16"

INVOICE TO		SHIP TO	
DIVISION OF HIGHWAYS DISTRICT NINE 146 STONEHOUSE RD LEWISBURG WV US		DIVISION OF HIGHWAYS DISTRICT NINE SUMMERS COUNTY HEADQUARTERS 20414 STATE RT 12 HINTON WV US	

Line	Comm Ln Desc	Qty	Unit Issue	Unit Price	Total Price
6	(44 each) PL 3/8"X4"X8"	112.35000	LB		

Comm Code	Manufacturer	Specification	Model #
30264000			

Extended Description:
(44 each) PL 3/8"X4"X8"

INVOICE TO		SHIP TO	
DIVISION OF HIGHWAYS DISTRICT NINE 146 STONEHOUSE RD LEWISBURG WV US		DIVISION OF HIGHWAYS DISTRICT NINE SUMMERS COUNTY HEADQUARTERS 20414 STATE RT 12 HINTON WV US	

Line	Comm Ln Desc	Qty	Unit Issue	Unit Price	Total Price
7	(16 each) PL 1/4"X6"X6"	20.40000	LB		

Comm Code	Manufacturer	Specification	Model #
30264000			

Extended Description:
(16 each) PL 1/4"X6"X6"

INVOICE TO		SHIP TO	
DIVISION OF HIGHWAYS DISTRICT NINE 146 STONEHOUSE RD LEWISBURG WV US		DIVISION OF HIGHWAYS DISTRICT NINE SUMMERS COUNTY HEADQUARTERS 20414 STATE RT 12 HINTON WV US	

Line	Comm Ln Desc	Qty	Unit Issue	Unit Price	Total Price
8	(5 each) Expanded Metal, 1/4"x11"x8' (3/4"x#9)	184.00000	LB		

Comm Code	Manufacturer	Specification	Model #
30264000			

Extended Description:
(5 each) Expanded Metal, 1/4"x11"x8' (3/4"x#9)

INVOICE TO		SHIP TO	
DIVISION OF HIGHWAYS DISTRICT NINE 146 STONEHOUSE RD LEWISBURG WV US		DIVISION OF HIGHWAYS DISTRICT NINE SUMMERS COUNTY HEADQUARTERS 20414 STATE RT 12 HINTON WV US	

Line	Comm Ln Desc	Qty	Unit Issue	Unit Price	Total Price
9	(5 each) Angle, 3"x3"x1/4"x20'	940.00000	LB		

Comm Code	Manufacturer	Specification	Model #
30101504			

Extended Description:
(5 each) Angle, 3"x3"x1/4"x20'

INVOICE TO		SHIP TO	
DIVISION OF HIGHWAYS DISTRICT NINE 146 STONEHOUSE RD LEWISBURG WV US		DIVISION OF HIGHWAYS DISTRICT NINE SUMMERS COUNTY HEADQUARTERS 20414 STATE RT 12 HINTON WV US	

Line	Comm Ln Desc	Qty	Unit Issue	Unit Price	Total Price
10	(10 each) Angle, 1 1/2"x1 1/2"x20'	468.00000	LB		

Comm Code	Manufacturer	Specification	Model #
30101504			

Extended Description:
(10 each) Angle, 1 1/2"x1 1/2"x20'

INVOICE TO		SHIP TO	
DIVISION OF HIGHWAYS DISTRICT NINE 146 STONEHOUSE RD LEWISBURG WV US		DIVISION OF HIGHWAYS DISTRICT NINE SUMMERS COUNTY HEADQUARTERS 20414 STATE RT 12 HINTON WV US	

Line	Comm Ln Desc	Qty	Unit Issue	Unit Price	Total Price
11	All Fasteners Required	1.00000	LS		

Comm Code	Manufacturer	Specification	Model #
31161600			

Extended Description:
All Fasteners Required

INVOICE TO		SHIP TO	
DIVISION OF HIGHWAYS DISTRICT NINE 146 STONEHOUSE RD LEWISBURG WV US		DIVISION OF HIGHWAYS DISTRICT NINE SUMMERS COUNTY HEADQUARTERS 20414 STATE RT 12 HINTON WV US	

Line	Comm Ln Desc	Qty	Unit Issue	Unit Price	Total Price
12	Fabrication and Paint	0.00000			

Comm Code	Manufacturer	Specification	Model #
86131502			

Extended Description:
Fabrication and Paint

SCHEDULE OF EVENTS

Line	Event	Event Date
1	Technical Questions due at 11:00am	2022-07-14

SOLICITATION NUMBER:
Addendum Number:

The purpose of this addendum is to modify the solicitation identified as (“Solicitation”) to reflect the change(s) identified and described below.

Applicable Addendum Category:

- Modify bid opening date and time
- Modify specifications of product or service being sought
- Attachment of vendor questions and responses
- Attachment of pre-bid sign-in sheet
- Correction of error
- Other

Description of Modification to Solicitation:

Additional Documentation: Documentation related to this Addendum (if any) has been included herewith as Attachment A and is specifically incorporated herein by reference.

Terms and Conditions:

1. All provisions of the Solicitation and other addenda not modified herein shall remain in full force and effect.
2. Vendor should acknowledge receipt of all addenda issued for this Solicitation by completing an Addendum Acknowledgment, a copy of which is included herewith. Failure to acknowledge addenda may result in bid disqualification. The addendum acknowledgement should be submitted with the bid to expedite document processing.

ATTACHMENT A

PROJECT NUMBERS		DISTRICT	COUNTY	SHEET NO.	TOTAL
STATE	FEDERAL				
PM524B	N/A	9	SUMMERS	2	4

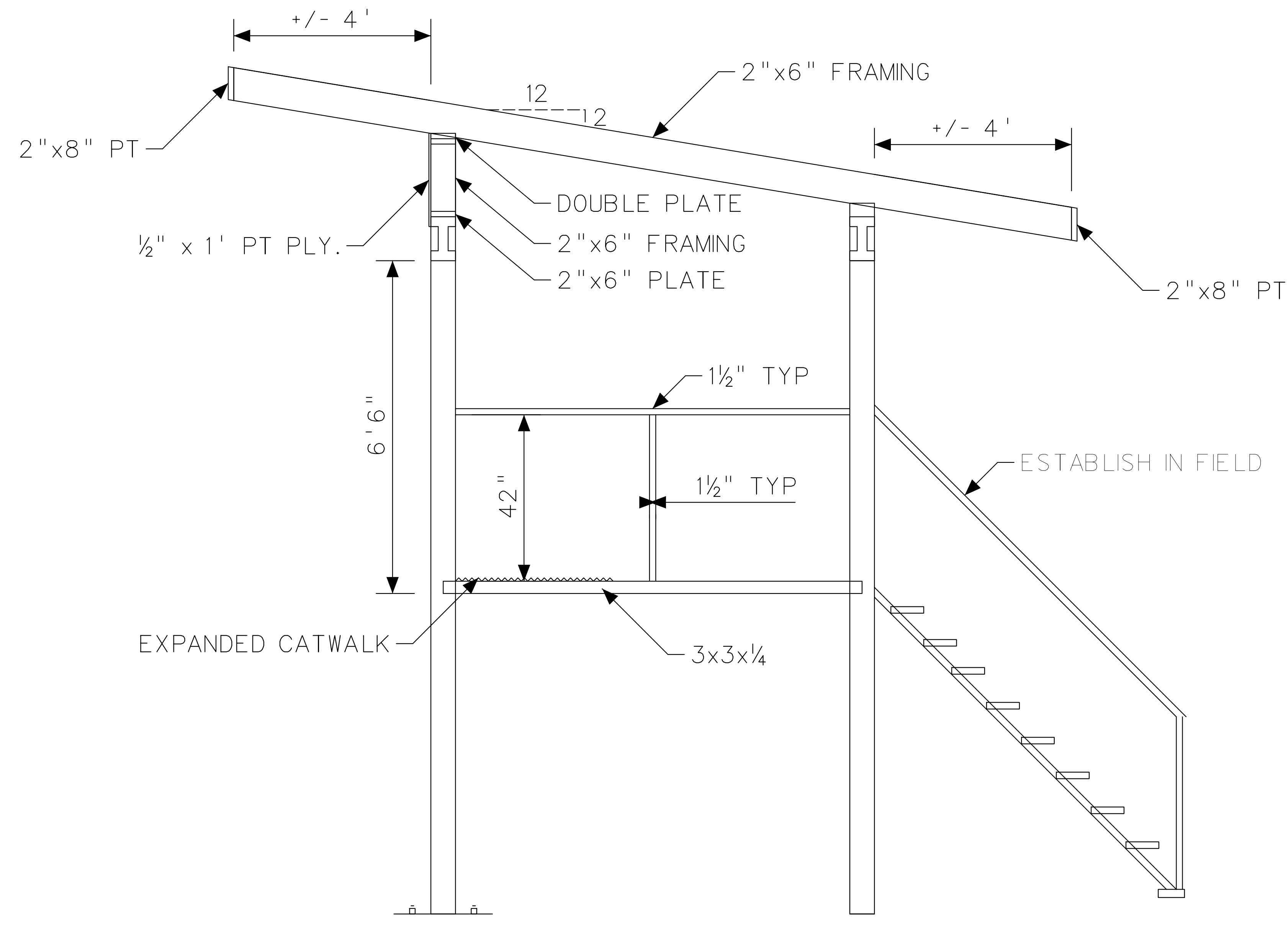

SECTION B-B
DETAILED

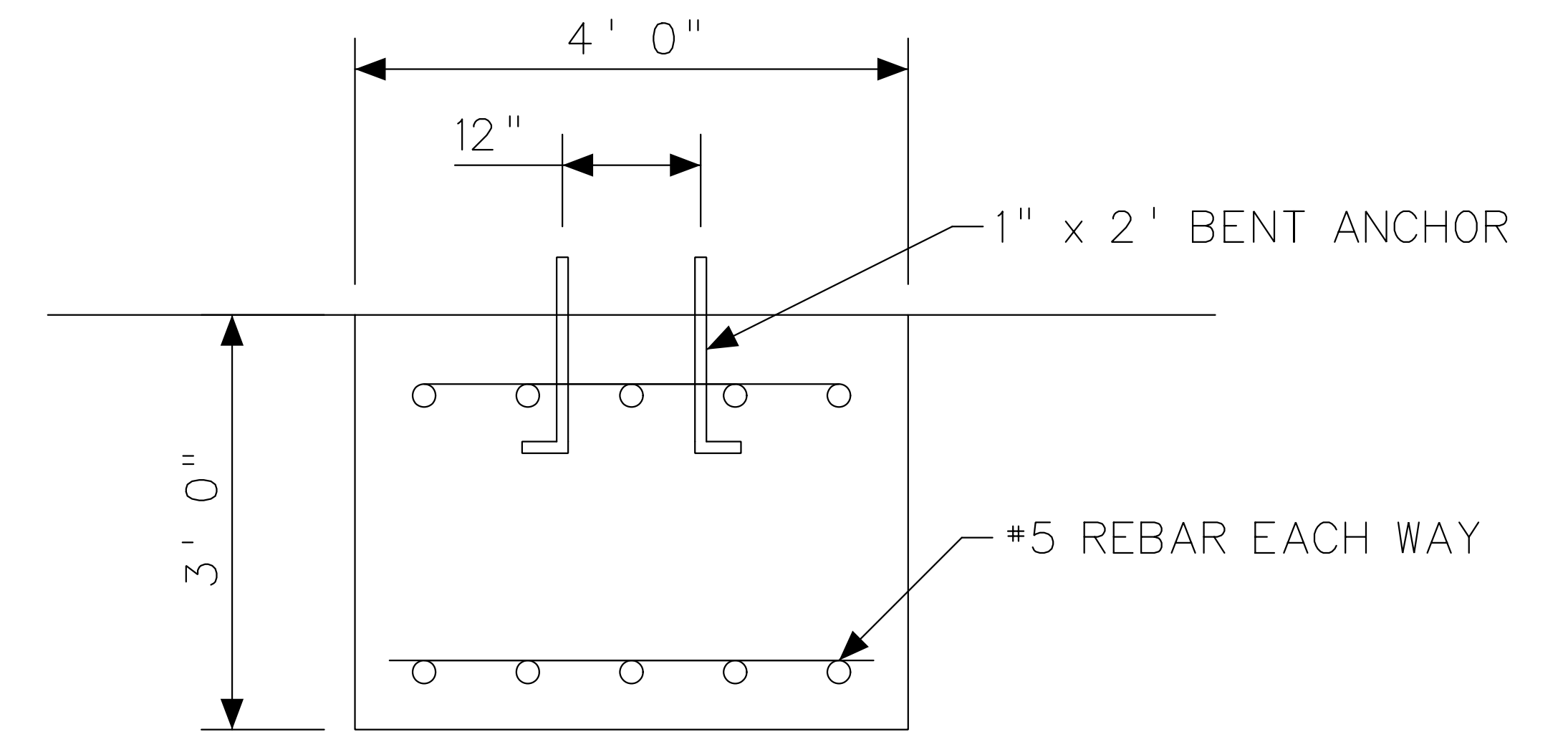

SECTION C-C

NO.	REVISION	DATE	BY

WEST VIRGINIA DEPARTMENT OF TRANSPORTATION
DIVISION OF HIGHWAYS
ENGINEERING

DESIGNED CFB	DATE 2/22	CHECKED ---	DATE 1/21
DRAWN EDE	DATE 3/22	REVIEWED ---	DATE 1/21

SUMMERS COUNTY
SPREADER
RACK

PLAN SHEET

SHEET 2 OF 4
DESIGN NUMBER XXXX

20-APR-2022 14:49 p:\DOT\B6P\W\H\executive.state.wv.gov\pw-primary\Documents\WVDOH\ORGS\D09\BRIDGE\DESIGN\STAFF\CADD\DE Projects\Summers County Salt Spreader Shed\Design 2 (Selected Design +5-22)\Salt Shed Design 2

PROJECT NUMBERS		DISTRICT	COUNTY	SHEET NO.	TOTAL
STATE	FEDERAL				
PM524B	N/A	9	SUMMERS	3	4

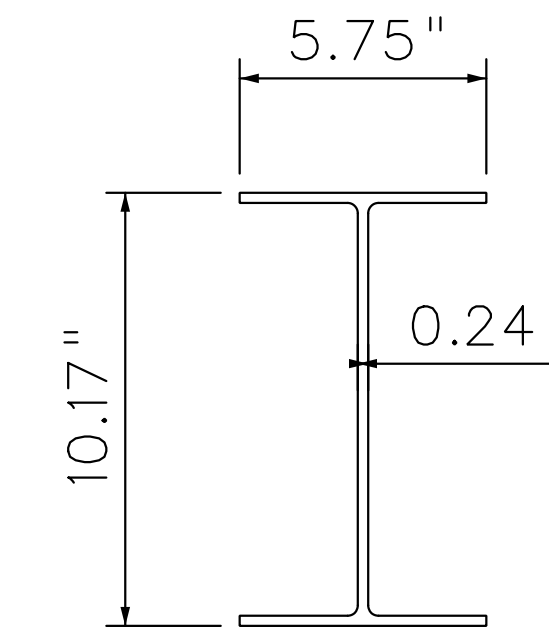
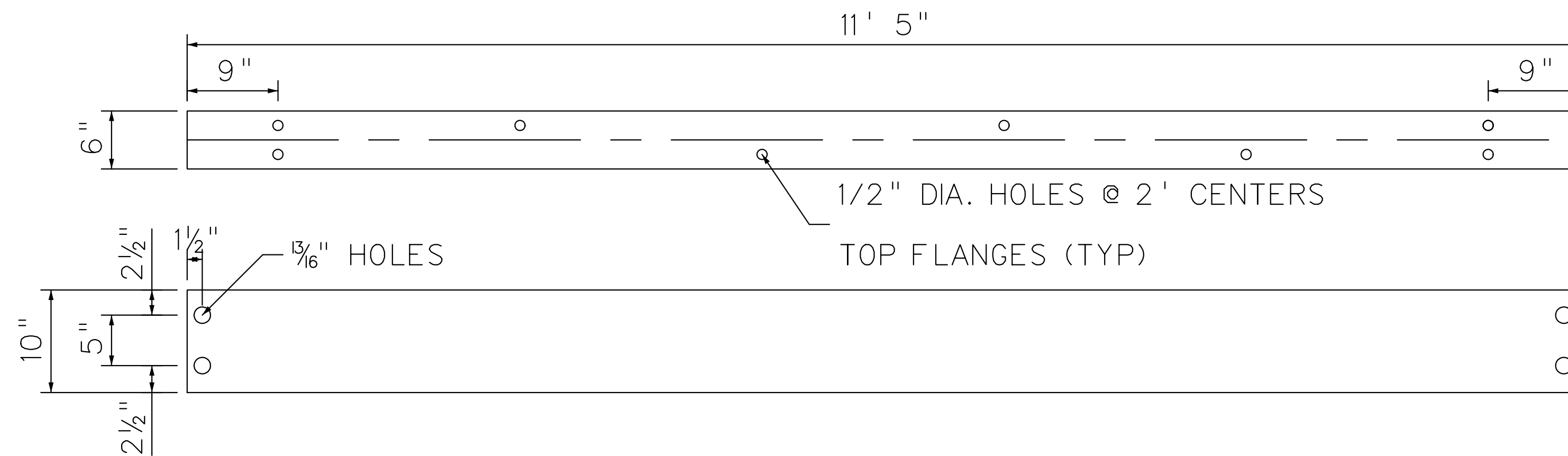

W10x22

(FOURTEEN) BEAM - MK 1B1

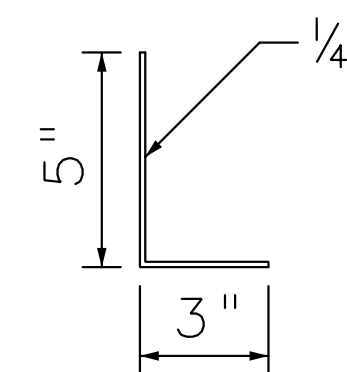
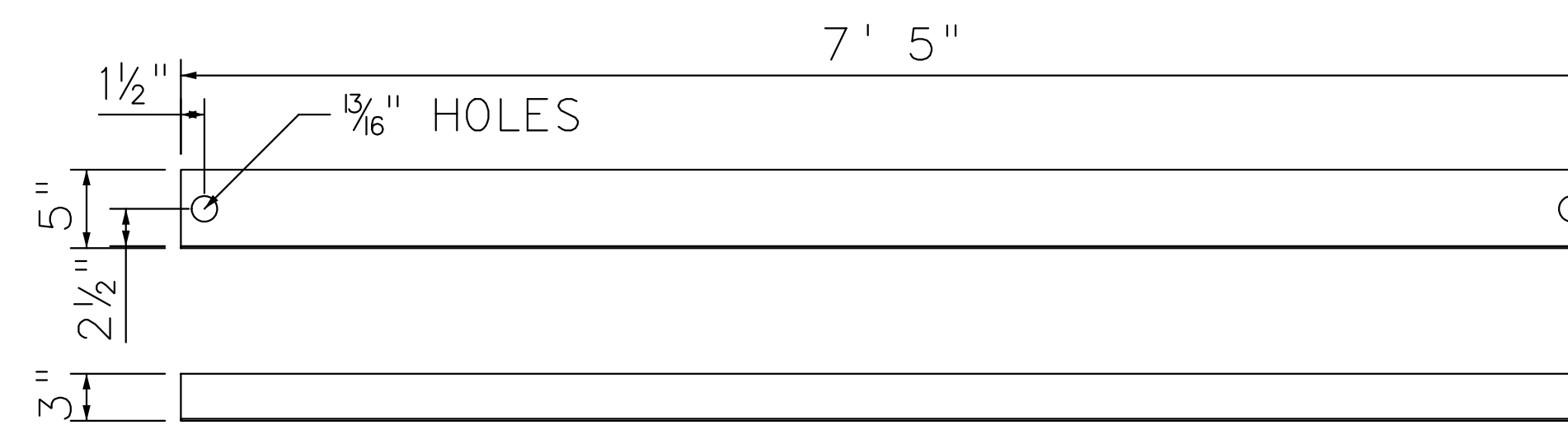

3" X 5" X 1/4"

(EIGHT) BEAM - MK 1B2

NO.	REVISION	DATE	BY

WEST VIRGINIA DEPARTMENT OF TRANSPORTATION
DIVISION OF HIGHWAYS
ENGINEERING

DESIGNED CFB	DATE 2/22	CHECKED ---	DATE 1/21
DRAWN EDE	DATE 3/22	REVIEWED ---	DATE 1/21

SUMMERS COUNTY
SPREADER
RACK

BEAM SHEET

SHEET
3 OF 4
DESIGN NUMBER XXXX

PROJECT NUMBERS		DISTRICT	COUNTY	SHEET NO.	TOTAL
STATE	FEDERAL				
PM5241B	N/A	9	SUMMERS	4	4

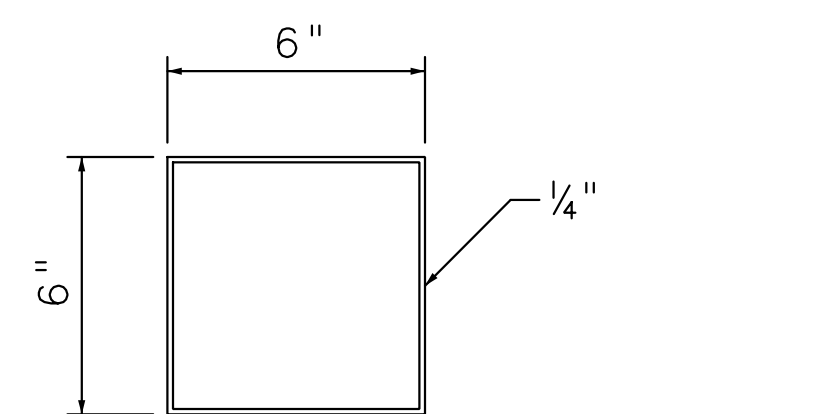
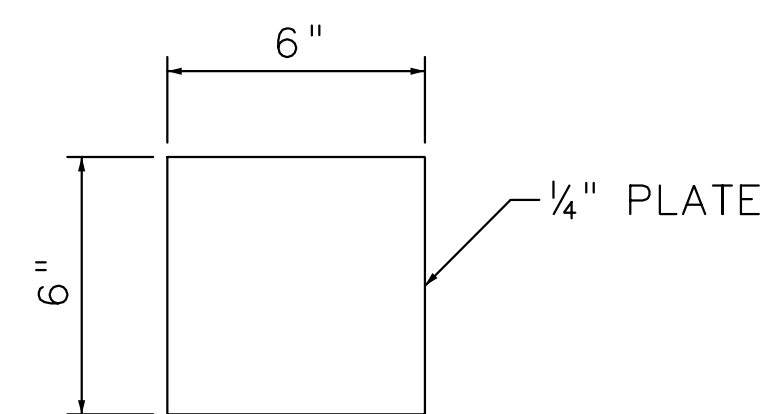
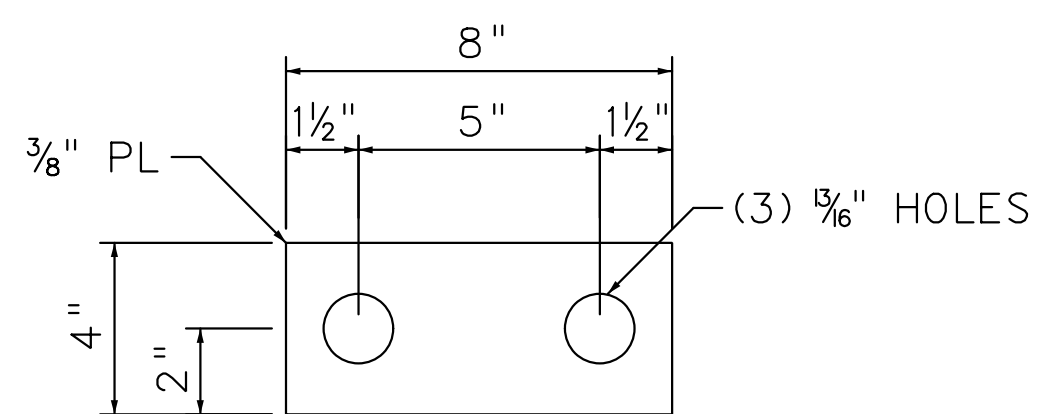
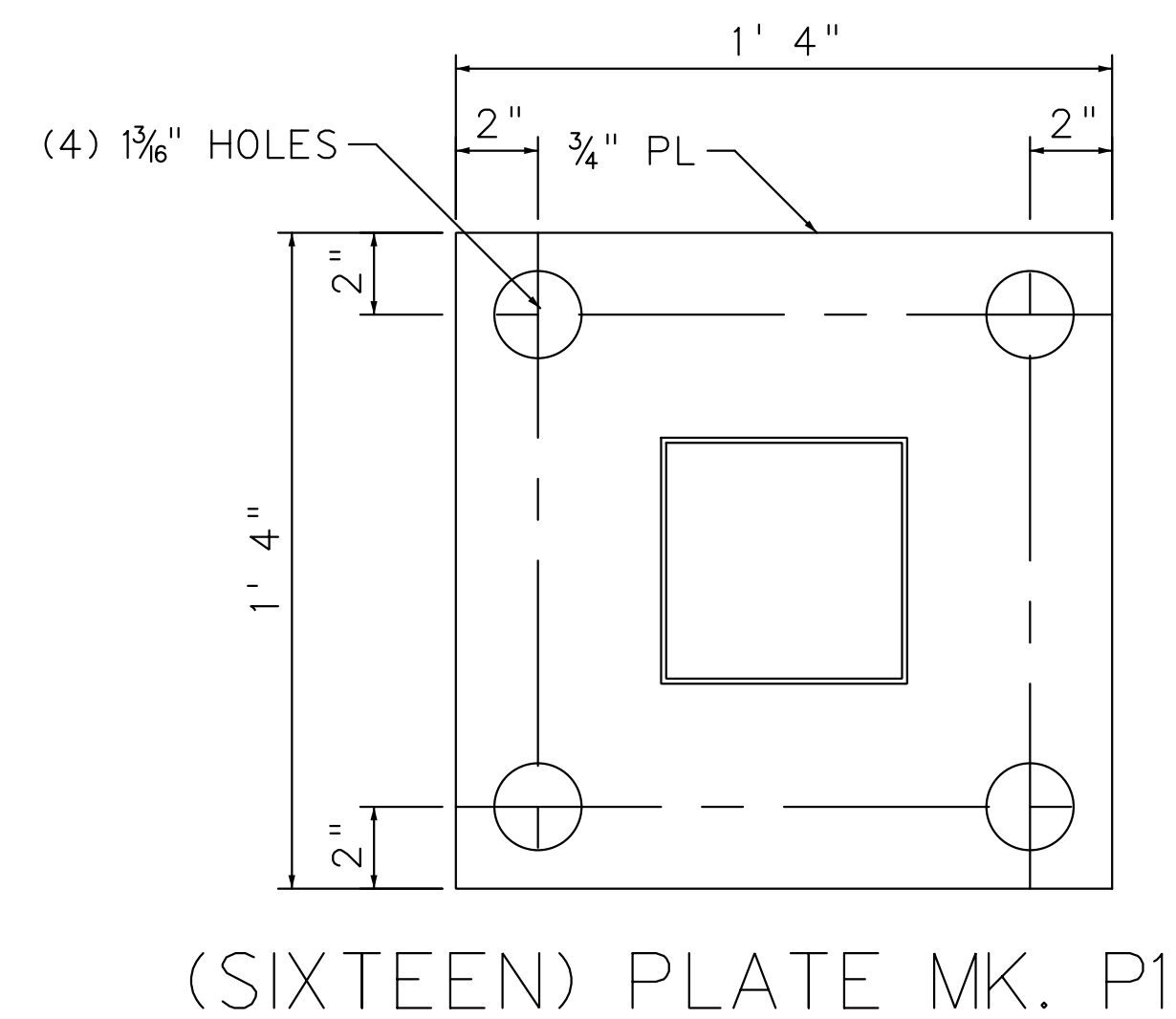
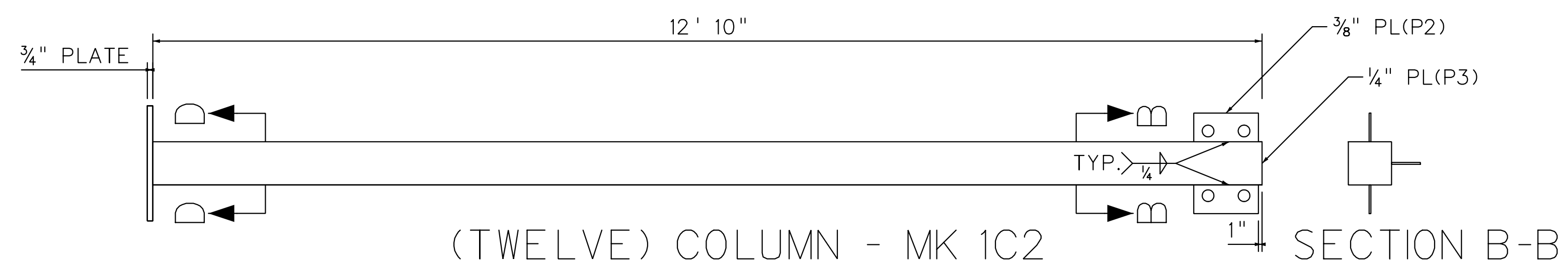
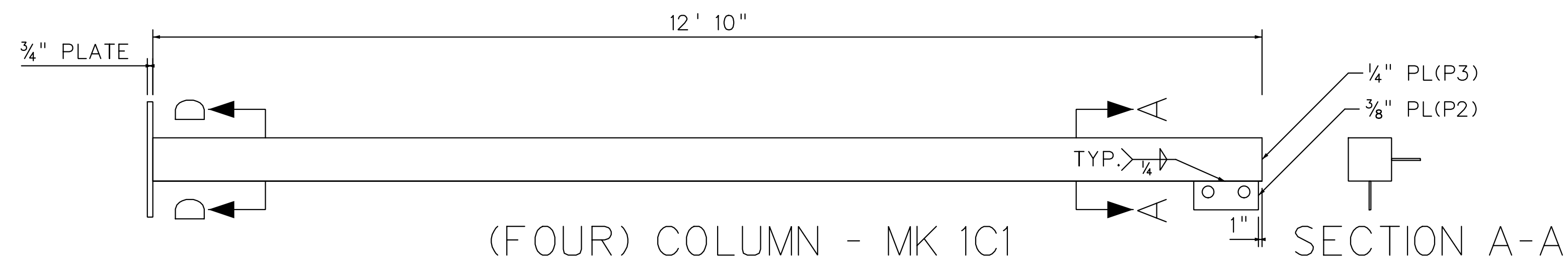

MK	QTY	DESCRIPTION	LENGTH		REMARKS	WEIGHT (LBS)
			FEET	INCHES		
1B1	14	W10x22	11	5	ASTM A992 GR. 50	3516.33
1B2	8	3 x 5 x 1/4	7	5	ASTM A992 GR. 50	391.60
1C1	4	HSS6 x 6 x 1/4	12	10	ASTM A500 GR. 46	976.36
1C2	12	HSS6 x 6 x 1/4	12	10	ASTM A500 GR. 46	2929.08
P1	16	PL 3/4 x 16	0	16	ASTM A36 GR. 36	1161.60
P2	44	PL 3/8 x 4	0	8	ASTM A36 GR. 36	112.35
P3	16	PL 1/4 x 6	0	6	ASTM A36 GR. 36	20.40
EM	5	PL 1/4 X 11	8	0	EXPANDED METAL	184.00
AI1	5	3 x 3 x 1/4	20	0	ANGLE IRON	940
AI2	10	1 1/2 x 1 1/2 x 1/4	20	0	ANGLE IRON	468

NOTE: INCLUDE ALL 3/4 STRUCTURAL BOLTS, WASHERS, AND NUTS (A325)
ALL STRUCTURAL STEEL TO BE COATED WITH RED PRIMER

NO.	REVISION	DATE	BY

WEST VIRGINIA DEPARTMENT OF TRANSPORTATION
DIVISION OF HIGHWAYS
ENGINEERING

DESIGNED CFB	DATE 2/22	CHECKED ---	DATE 1/21
DRAWN EDE	DATE 3/22	REVIEWED ---	DATE 1/21

SUMMERS COUNTY
SPREADER
RACK

COLUMN SHEET

SHEET 4 OF 4 DESIGN NUMBER XXXX
--

ADDENDUM ACKNOWLEDGEMENT FORM
SOLICITATION NO.: _____

Instructions: Please acknowledge receipt of all addenda issued with this solicitation by completing this addendum acknowledgment form. Check the box next to each addendum received and sign below. Failure to acknowledge addenda may result in bid disqualification.

Acknowledgment: I hereby acknowledge receipt of the following addenda and have made the necessary revisions to my proposal, plans and/or specification, etc.

Addendum Numbers Received:

(Check the box next to each addendum received)

- | | |
|--|--|
| <input checked="" type="checkbox"/> Addendum No. 1 | <input type="checkbox"/> Addendum No. 6 |
| <input type="checkbox"/> Addendum No. 2 | <input type="checkbox"/> Addendum No. 7 |
| <input type="checkbox"/> Addendum No. 3 | <input type="checkbox"/> Addendum No. 8 |
| <input type="checkbox"/> Addendum No. 4 | <input type="checkbox"/> Addendum No. 9 |
| <input type="checkbox"/> Addendum No. 5 | <input type="checkbox"/> Addendum No. 10 |

I understand that failure to confirm the receipt of addenda may be cause for rejection of this bid. I further understand that any verbal representation made or assumed to be made during any oral discussion held between Vendor's representatives and any state personnel is not binding. Only the information issued in writing and added to the specifications by an official addendum is binding.

ACF Group
Company

John B. Harvey
Authorized Signature

7/14/2022
Date

Item Number	Quantity	Unit of Measure	Description	Unit Price	Extended Amount
1	3516.33	Pounds	14 EA. W10x22x11'5" per Drawing (ASTM A992 GR.50)	1.49	\$ 5,239.33
2	391.6	Pounds	8 EA. Angle, 3x5x1/4x7'5" per Drawing (ASTM A992 GR.50)	2.05	\$ 802.78
3	976.36	Pounds	4 EA. HSS6x6x1/4"x12'10" per Drawing (ASTM A500 GR. 46)	1.65	\$ 1,610.99
4	2929.08	Pounds	12 EA. HSS6X6X1/4x12'10" per Drawing (ASTM A500 GR. 46)	1.65	\$ 4,832.98
5	1161.6	Pounds	16 EA. PL 3/4"x16"x16" per Drawing (ASTM A36 GR.36)	1.05	\$ 1,219.68
6	112.35	Pounds	44 EA. PL 3/8"x4"x8" per Drawing (ASTM A36 GR. 36)	1.84	\$ 206.72
7	20.4	Pounds	16 EA. PL 1/4"x6"x6" per Drawing (ASTM A36 GR.36)	2.75	\$ 56.10
8	184	Pounds	5 EA. Expanded Metal, 1/4"x11"x8' (3/4"x#9) per Drawing	4.23	\$ 778.32
9	940	Pounds	5 EA. Angle Iron, 3"x3"x1/4"x20' (ASTM A992 GR.50)	0.58	\$ 545.20
10	468	Pounds	10 EA. Angle Iron, 1 1/2"x1 1/2"x20' (ASTM A992 GR.50)	1.96	\$ 917.28
11	1	Each	All Fasteners required	1980	\$ 1,980.00
12	1	Each	Fabrication Charge	12105	\$ 12,105.00
13	1.00	Each	Delivery	1250	\$ 1,250.00
					TOTAL
					\$ 31,544.39

STATE OF WEST VIRGINIA
PURCHASING AFFIDAVIT

CONSTRUCTION CONTRACTS: Under W. Va. Code § 5-22-1(i), the contracting public entity shall not award a construction contract to any bidder that is known to be in default on any monetary obligation owed to the state or a political subdivision of the state, including, but not limited to, obligations related to payroll taxes, property taxes, sales and use taxes, fire service fees, or other fines or fees.

ALL CONTRACTS: Under W. Va. Code §15A-3-14, no contract or renewal of any contract may be awarded by the state or any of its political subdivisions to any vendor or prospective vendor when the vendor or prospective vendor or a related party to the vendor or prospective vendor is a debtor and: (1) the debt owed is an amount greater than one thousand dollars in the aggregate; or (2) the debtor is in employer default.

EXCEPTION: The prohibition listed above does not apply where a vendor has contested any tax administered pursuant to chapter eleven of the W. Va. Code, workers' compensation premium, permit fee or environmental fee or assessment and the matter has not become final or where the vendor has entered into a payment plan or agreement and the vendor is not in default of any of the provisions of such plan or agreement.

DEFINITIONS:

"Debt" means any assessment, premium, penalty, fine, tax or other amount of money owed to the state or any of its political subdivisions because of a judgment, fine, permit violation, license assessment, defaulted workers' compensation premium, penalty or other assessment presently delinquent or due and required to be paid to the state or any of its political subdivisions, including any interest or additional penalties accrued thereon.

"Employer default" means having an outstanding balance or liability to the old fund or to the uninsured employers' fund or being in policy default, as defined in W. Va. Code § 23-2c-2, failure to maintain mandatory workers' compensation coverage, or failure to fully meet its obligations as a workers' compensation self-insured employer. An employer is not in employer default if it has entered into a repayment agreement with the Insurance Commissioner and remains in compliance with the obligations under the repayment agreement.

"Related party" means a party, whether an individual, corporation, partnership, association, limited liability company or any other form or business association or other entity whatsoever, related to any vendor by blood, marriage, ownership or contract through which the party has a relationship of ownership or other interest with the vendor so that the party will actually or by effect receive or control a portion of the benefit, profit or other consideration from performance of a vendor contract with the party receiving an amount that meets or exceeds five percent of the total contract amount.

AFFIRMATION: By signing this form, the vendor's authorized signer affirms and acknowledges under penalty of law for false swearing (W. Va. Code §61-5-3) that: (1) for construction contracts, the vendor is not in default on any monetary obligation owed to the state or a political subdivision of the state, and (2) for all other contracts, that neither vendor nor any related party owe a debt as defined above and that neither vendor nor any related party are in employer default as defined above, unless the debt or employer default is permitted under the exception above.

WITNESS THE FOLLOWING SIGNATURE:

Vendor's Name: KODIAK MANUFACTURING

Authorized Signature: John R. [Signature] Date: 3/31/2022

State of PENNSYLVANIA

County of FAYETTE, to-wit:

Taken, subscribed, and sworn to before me this 31st day of MARCH, 2022

My Commission expires ~~PA OCTOBER~~ OCTOBER 02, 2023

AFFIX SEAL HERE

Commonwealth of Pennsylvania - Notary Seal
Patricia J. Larson, Notary Public
Fayette County
My commission expires October 2, 2023
Commission number 1202039
Member, Pennsylvania Association of Notaries

NOTARY PUBLIC [Signature]