

**PROJECT NOTE**  
**CLEANING AND PAINTING**

**GENERAL**

All work performed according to this Project Note shall be considered incidental to Pay Item **688001, Clean and Paint Existing Steel Bridge.**

**DESCRIPTION**

The Bridge Paint Designation Label shall consist of painting on the fascia web of the exterior girder the following information: paint system, contractor, and the month-year the project was completed in accordance with this special provision and attached details.

**LOCATION**

The paint designation label will be located at abutment number one on the fascia web of the exterior girder with a southern or eastern orientation.

**PAINT SYSTEM**

The Contractor shall label the primer, intermediate and topcoat in accordance with the designated acronyms listed below.

<b>Paint System</b>	<b>Paint System Acronym</b>
Acrylic	A
Alkyd	AK
Calcium Sulfonate	CS
Epoxy Mastic	EM
Galvanizing	G
Inorganic Zinc	IZ
Metalizing	M
Micaceous Iron Oxide	MIO
Organic Zinc	OZ
Polyaspartic	PA
Polysiloxane	PS
Polyurea	PU
Silanes	S
Urethane	U

**Example:**

The paint system is *Organic Zinc Primer, Epoxy Intermediate, Urethane Topcoat*, the acronym would be *OZEU*. The paint system is *Organic Zinc Primer, Acrylic Intermediate, Acrylic Topcoat*, the acronym would be *OZAA*. There will be no differentiating between water-based or solvent-based acrylics.

## **CONTRACTOR**

The Contractor shall select the designated acronym for their company from the list below. If the company is not listed, the Engineer will contact Materials Control, Soils & Testing Division for a company acronym to be designated.

<b>Contractor</b>	<b>Contractor Acronym</b>
3-D's BRIDGE PAINTING CORP.	3DB
ATLAS CENTRAL, CORP.	AC
AVALOTIS PAINTING CO.	AP
ALLSTATE PAINTING & CONTACTING	APC
ADVANCE PAINTING SYSTEMS, INC.	APS
ABHE & SVOBODA, INC.	A&S
AUTO MART, INC.	AMI
BLASTECH ENTERPRISES, INC.	BEI
CORCON, INC.	COR
CENTRAL STATES CONTRACTING, INC.	CSC
DICK CORPORATION	DC
DAMALOS & SONS, INC.	DS
ELITE CONTRACTORS, INC.	EC
GLOBAL CONSTRUCTION, INC.	GC
GERONIMO PAINTING CO.	GP
G.T. MAGNUM PAINTING, INC.	GTM
HERCULES PAINTING CO.	HP
HARTMAN WALSH PAINTING CO.	HWP
INDUSTRIAL ENTERPRISE, SANDBLAST & PAINT, INC.	IESP
IPI INC.	IPI
JOHN B. CONOMOS, INC.	JBC
JEWELL PAINTING CO., INC.	JP
LEGEND PAINTING, INC.	LEG
LM LIGNOS ENTERPRISES	LL
LIBERTY MAINTENANCE, INC.	LM
MANGANAS ENTERPRISES, INC.	ME
M & J PAINTING CO.	MJ
MONOKO, INC.	MON
MPG CONSTRUCTION, INC.	MPG
MVP	MVP
NEW CASTLE CONSTRUCTION CO., INC.	NCC
NORTH STAR PAINTING CO., INC.	NSP
ODYSSEY CONTRACTING CORP.	OCC

PANTHERA PAINTING, INC.	PAN
ROYAL BRIDGE, INC.	RB
SEMINOLE EQUIPMENT, INC.	SE
SPECIALTY GROUPS, INC.	SG
SPYROS PAINTING, INC.	SP
SUPERIOR PAINTING & CONTRACTING	SPC
VIMAS PAINTING CO., INC.	VP
WHITMAN, REQUARDT & ASSOCIATES, LLP	WRA
W.Q. WATERS CO.	WQW
W.R. MOLLOHAN, INC.	WRM

### **MONTH-YEAR**

The Contractor shall label the month and year the paint project was completed.

### **Example:**

The paint project was completed in August 2004, the numbering format would be 0804.

### **LETTERING**

The Contractor shall apply the Bridge Paint Designation Label with a semi-gloss paint compatible with the topcoat material.

The color of all lettering shall be **Black** in accordance with *AMS-Standard 37030*. The letter height, width and spacing shall be in accordance with the Attachment 1.

Attachment 1

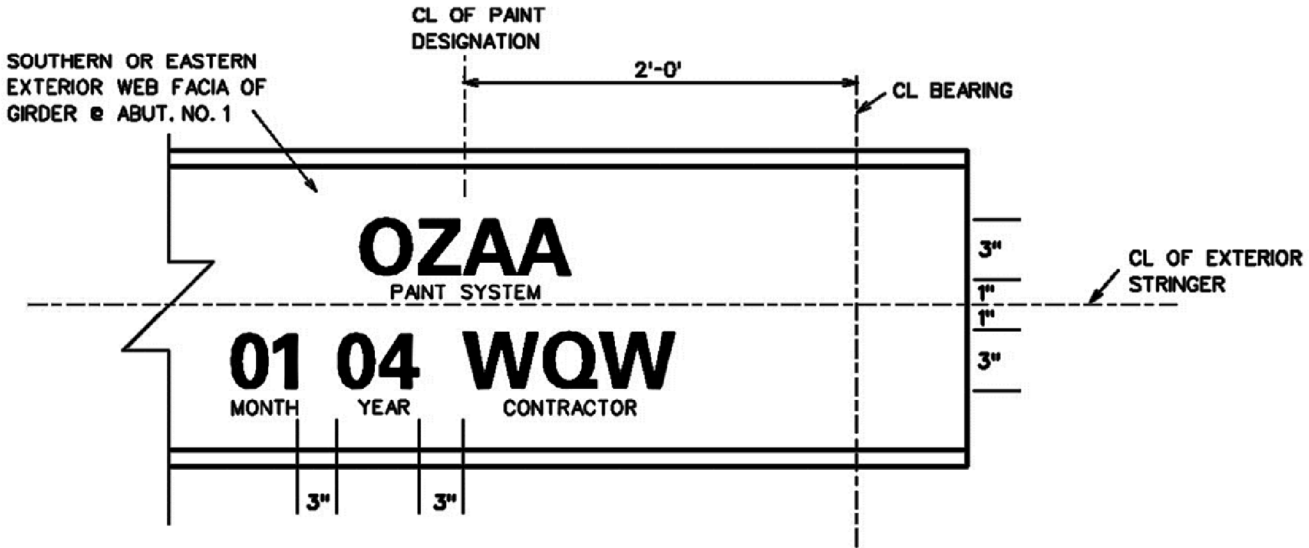

**EXAMPLE: BRIDGE PAINT DESIGNATION**

BLACK LEGEND ON TOP COAT COLOR

NOTES:

1. HEIGHT OF ALL LETTERING SHALL BE 3".
2. AVERAGE WIDTH OF ALL LETTERING SHALL BE 1 1/2".
3. SPACING BETWEEN LETTERS AND NUMBERS SHALL BE 1/2".
4. SPACING BETWEEN MONTH-YEAR AND YEAR-CONTRACTOR SHALL BE 3".

36th STREET BRIDGE  
+ RAMP A, B & PEDESTRIAN WALKWAY

KANAWHA  
COUNTY

BRIDGE NO. 2798  
SS20-0003-0-TI 00