



**WEST VIRGINIA DEPARTMENT OF TRANSPORTATION
DIVISION OF HIGHWAYS
STANDARD DETAILS BOOK
VOLUME I
DRAINAGE, GUARDRAIL, PAVEMENT,
FENCE, MARKERS AND MAILBOX**



ISSUE DATE: MAY, 2016

TABLE OF CONTENTS

DRAINAGE

DR 1	PIPE CULVERT HEADWALLS
DR 2	PIPE CULVERT WINGWALLS
DR 3	END SECTIONS FOR CORRUGATED STEEL PIPES AND PIPE ARCHES
DR 4*	SAFETY SLOPE END SECTIONS FOR CONCRETE PIPE
DR 5	SAFETY SLOPE END SECTION FOR CIRCULAR & ARCHED STEEL PIPE
DR 6A	TYPE A INLET
DR 6B	TYPE B INLET
DR 6C	TYPE C INLET
DR 6D	TYPE D INLET
DR 6E	TYPE E INLET
DR 6F	TYPE F INLET
DR 6G	TYPE G INLET
DR 6H	TYPE H INLET
DR 6S	SLOT INLET
DR 6X	INLET CASTINGS
DR 7A	TYPE A MANHOLE
DR 7B	TYPE B MANHOLE
DR 7X	MANHOLE CASTINGS
DR 8*	MISCELLANEOUS DRAINAGE
DR 9	REPAVING TRENCHES UNDER EXISTING PAVEMENT
DR 10*	TYPE F DRAINAGE PIPE TRENCH, CONCRETE COLLAR

GUARDRAIL

GR 1*	GUARDRAIL ELEMENTS
GR 2*	GUARDRAILS POSTS AND BLOCKS
GR 3*	DOUBLE-FACED GUARDRAIL POSTS
GR 4	CUT SLOPE TERMINAL
GR 4A	CUT SLOPE TERMINAL TYPE A SOFT SHALE OR SOIL
GR 4B	CUT SLOPE TERMINAL TYPE B SHALE OR ROC
GR 5	FLARED END TERMINAL
GR 6	TANGENT END TERMINAL
GR 7	SPECIAL TRAILING END TERMINAL
GR 9	GUARDRAIL BRIDGE TRANSITIONS AND CONNECTIONS
GR 10	W-BEAM BRIDGE TRANSITION TO SAFETY SLOPE STEEL POST WITH RUBRAIL
GR 11A	28-1/2" THRIE BEAM GUARDRAIL BRIDGE TRANSITION AND CONNECTION
GR 11B	31" THRIE BEAM GUARDRAIL BRIDGE TRANSITION AND CONNECTION
GR 11C	THRIE BEAM GUARDRAIL BRIDGE TRANSITION AND CONNECTION DETAILS
GR 15	GUARDRAIL MODIFICATIONS
GR 16	GUARDRAIL MODIFICATIONS FOR UNDERGROUND OBSTRUCTIONS
GR 18*	MEDIAN BARRIER TYPE X

PAVEMENT

PVT 1*	CONCRETE PAVEMENT JOINT LAYOUT AND TYPES
PVT 2	RUMBLE STRIPS, TYPE H JOINT, MODIFIED E JOINT
PVT 3	LONGITUDINAL TIE BOLT ASSEMBLY
PVT 4	LOAD TRANSFER UNIT
PVT 5	BRIDGE APPROACH EXPANSION JOINT: BRIDGE TRANSITION PAVEMENT WITH SKID RESISTANT OVERLAY, TYPE J JOINT
PVT 6	CONCRETE CURBING AND SIDEWALK
PVT 7*	SIDEWALK RAMPS
PVT 8*	CONCRETE PAVEMENT REPAIR

FENCE

F 1	R/W FENCE – CHAIN LINK 5' FABRIC HEIGHT
F 2	R/W FENCE – FARM FIELD WITH STEEL POSTS (3' – 11" FENCE FABRIC HEIGHT)
F 3	R/W FENCE – FARM FIELD WITH TREATED WOOD POSTS (3' – 11" FENCE FABRIC HEIGHT)
F 4	SUPER SILT FENCE

MARKERS AND MAILBOX

M 1	PROJECT MARKER, SURVEY MARKER
M 2	MAILBOX

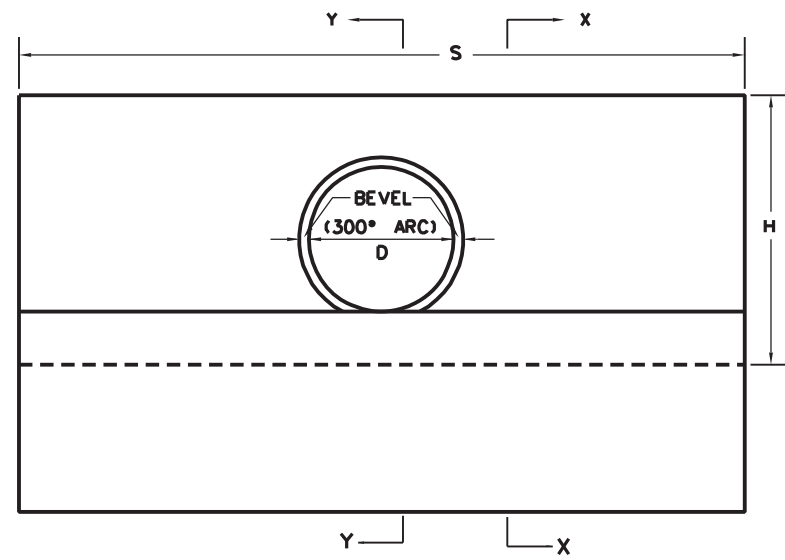

ELEVATION

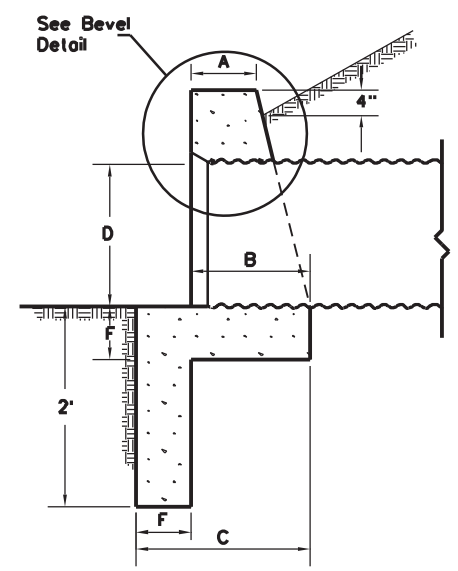

SECTION Y-Y

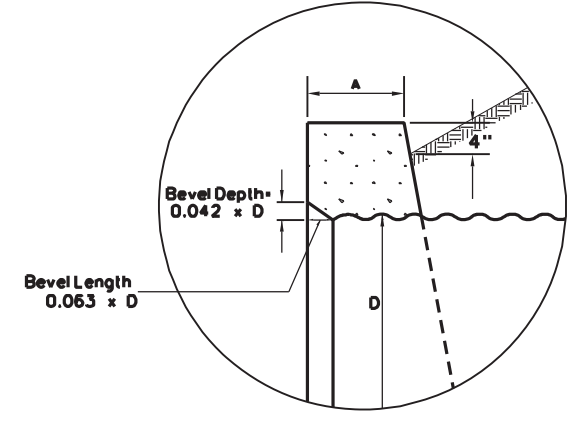

BEVEL DETAIL
(Section Thru Center Of Pipe)

	DIAMETER OF PIPE				
	12"	15"	18"	24"	30"
Depth	1/2"	3/4"	3/4"	1"	1 1/4"
Length	3/4"	1"	1 1/4"	1 1/2"	2"

NOTES

All concrete shall be Class "B" Concrete.
All concrete edges shall have a 3/4" x 45° chamfer. Chamfer on vertical edges shall be continued a minimum of one foot below finished ground line.

When headwalls are placed on the inlet end of corrugated metal pipe or skewed concrete pipe, a bevel shall be used at the inlet opening. The end of the pipe shall be set in from the face of the wall, as shown on the "Bevel Detail", and the bevel constructed from the end of the pipe to the face of the wall.

When headwalls are placed on the inlet end of concrete pipe, the "bell" or "groove" of the pipe shall be placed in the wall in lieu of the bevel, except when the pipe is to be cut for placing in skewed headwalls. The inside of the "bell" or "groove" shall be filled with concrete up to the flow line.

Bevels are not required on outlet headwalls.

Reinforcing fabric shall conform to the requirements of 709.3 and 709.4 of the Specifications.

Reinforcing fabric, as detailed herein, shall be used in all walls of all headwall structures. The covering for the fabric shall be two inches, measured from the surface of the concrete to the face of the wire, unless otherwise specified. The fabric shall be cut as necessary to accommodate the pipe opening in the wall and may be otherwise cut or field bent to fit the structure.

In lieu of the reinforcing fabric described above, as shown reinforcing steel bars, meeting the requirements of 709.1 of the Specification, may be used in these structures. Covering for the reinforcing shall be two inches, measured from the surface of the concrete to the face of the bars, unless otherwise specified. Bars shall be furnished in such lengths, or field bent or cut as necessary, to fit the structures and to accommodate the pipe opening in the walls.

Keyed or doweled type construction joints, acceptable to the Engineer, may be used during construction.

The pay quantity for Straight Headwalls, constructed in accordance with the details herein, will be the cubic yards of Class B Concrete specified herein.

Cost of all reinforcing fabric and reinforcing bars shall be included in the unit price bid for "Class B Concrete".

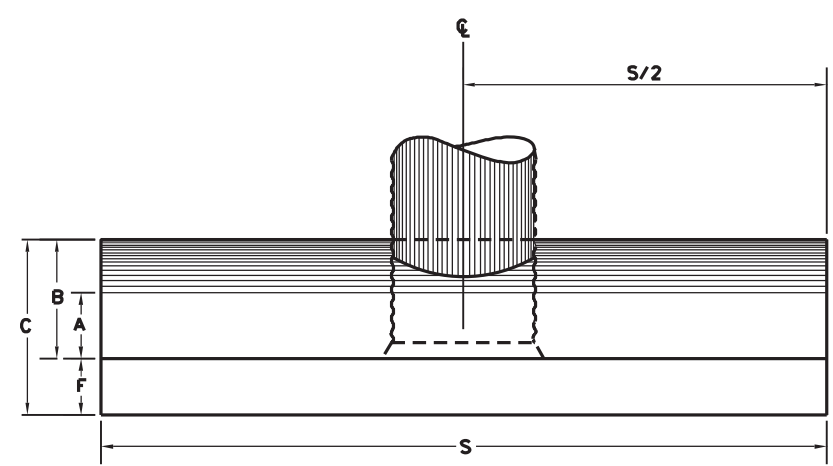

PLAN VIEW

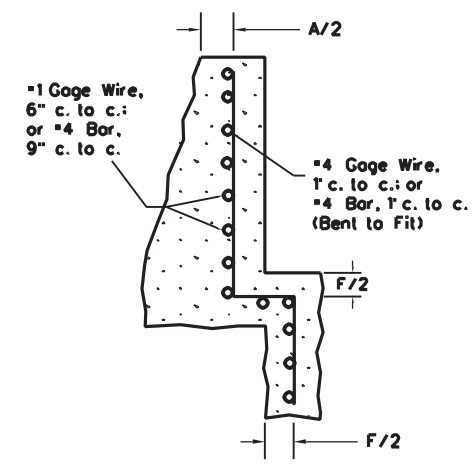

SECTION X-X
(Showing Reinforcing Details)

STRAIGHT HEADWALL
(Corrugated Metal Pipe Shown)

	DIAMETER OF PIPE				
	12"	15"	18"	24"	30"
A	0'-6"	0'-8"	0'-9"	0'-11"	1'-0"
B	0'-11"	1'-2"	1'-4"	1'-8"	1'-10"
C	1'-5"	1'-9"	2'-0"	2'-5"	2'-8"
D	1'-0"	1'-3"	1'-6"	2'-0"	2'-6"
F	0'-6"	0'-7"	0'-8"	0'-9"	0'-10"
H	2'-3"	2'-10"	3'-2"	3'-9"	4'-4"
S	5'-0"	6'-3"	7'-6"	10'-0"	12'-6"

QUANTITIES		CU. YDS. CLASS B CONCRETE				
R.C.P.	0.46	0.82	1.22	2.20	3.35	
C.M.P.	0.47	0.85	1.27	2.29	3.48	

WEST VIRGINIA DEPARTMENT OF TRANSPORTATION
DIVISION OF HIGHWAYS
STANDARD DETAIL

PREPARED 7-1-99
REVISION DATE

PIPE CULVERT
HEADWALLS

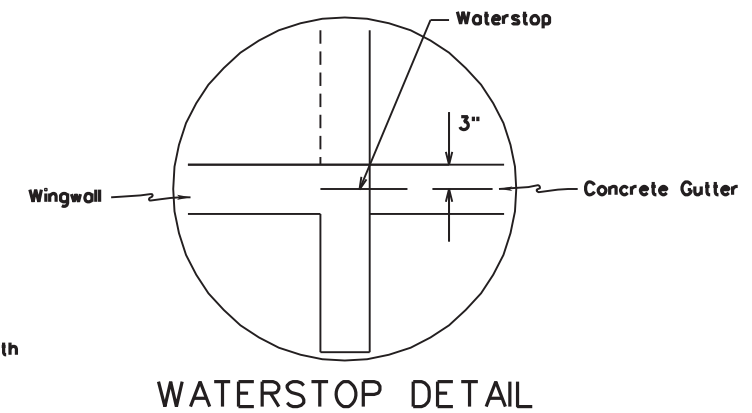
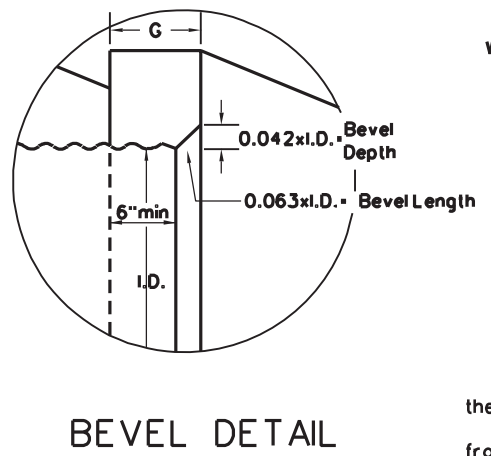
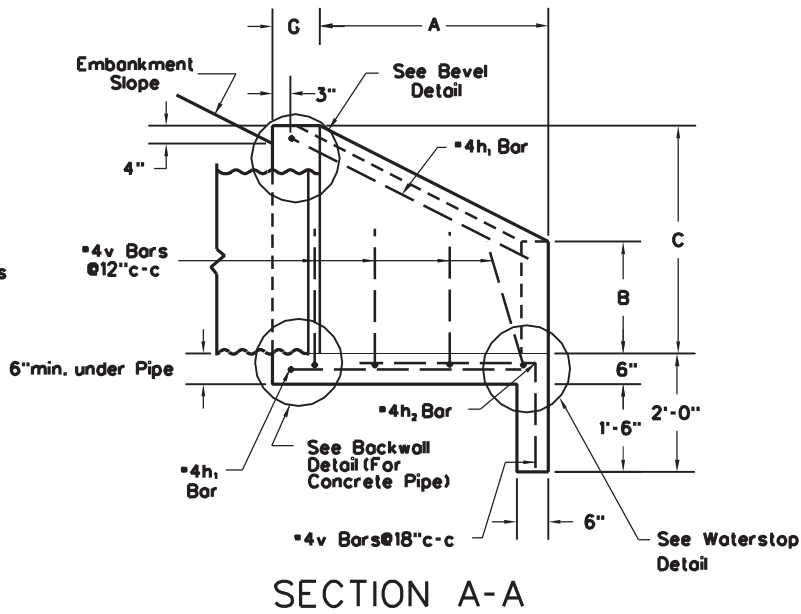
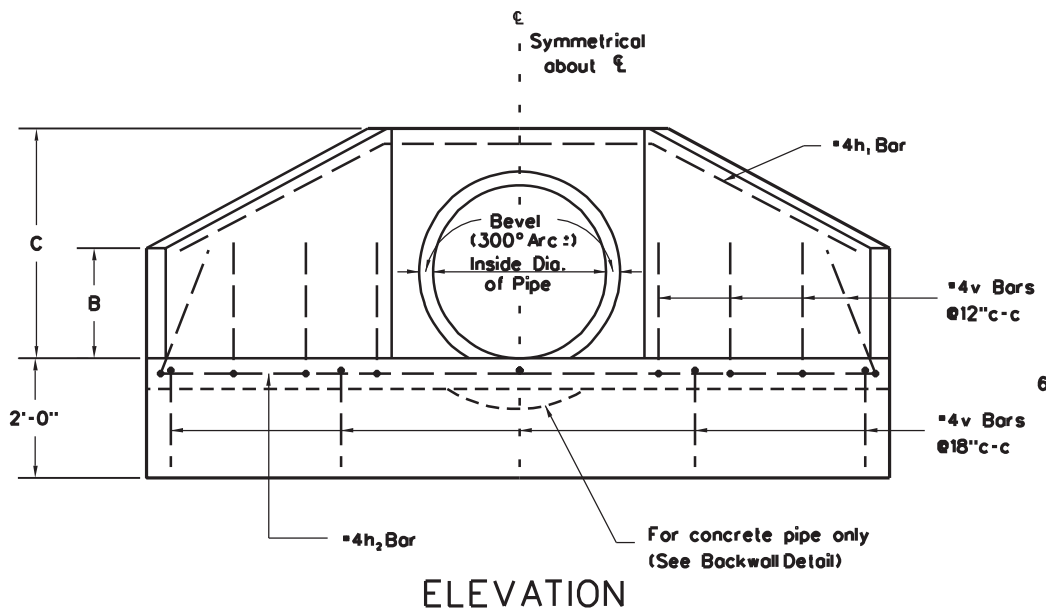

NOTES

All concrete shall be Class B Concrete.

Reinforcing steel shall be new billet steel and shall conform to the requirements of 709.1 of the Specifications.

The covering for Reinforcing Steel shall be 2" measured from the surface of the concrete to the face of the bar, unless otherwise noted on the Plans. Reinforcement in members where concrete is deposited on the ground shall have 3" of concrete from the face of the bar to the ground contact surface.

All exposed edges shall have a 3/4" x 45° chamfer. Chamfer on vertical edges shall be continued a minimum of one foot below finished ground line.

When wingwalls are placed on the inlet end of corrugated metal or structural plate pipe, a bevel shall be used at the inlet opening. The end of the pipe shall be set in from the face of the wall as shown on the "Bevel Detail", and the bevel constructed from the end of the pipe to the face of the wall.

When wingwalls are placed on the inlet end of concrete pipe, the "bell" or "groove" of the pipe shall be placed in the wall, and the inside of the "bell" or "groove" shall be filled with concrete up to the flow line.

Bevels are not required on outlet wingwalls or on inlet wingwalls for concrete pipe.

Keyed or doweled type construction joints, acceptable to the Engineer, may be used during construction.

If embankment slope above wingwalls is flatter than 2:1, provide wings for 2:1 slope and warp embankment to 2:1 slope at wingwall.

The pay quantity for wingwalls, constructed in accordance with the details herein, will be the cubic yards of Class B Concrete specified on this sheet. Cost of all reinforcing steel shall be included in the unit price bid for Class B Concrete.

Waterstop meeting the requirements of 708.10 shall be placed as shown when concrete gutter is to abut the wingwall.

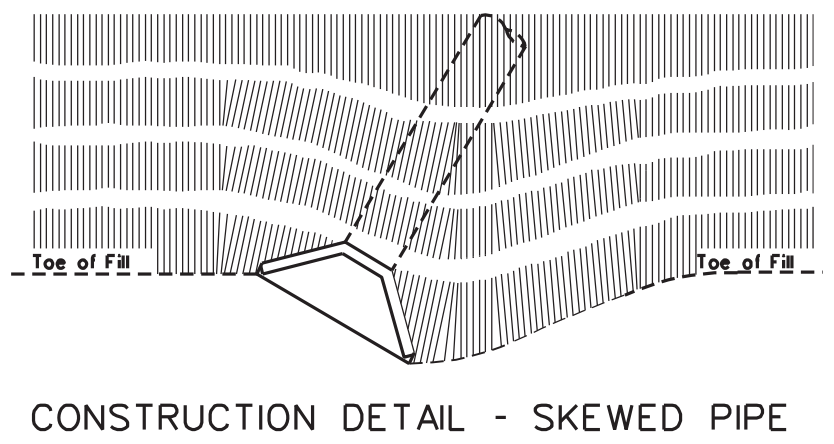
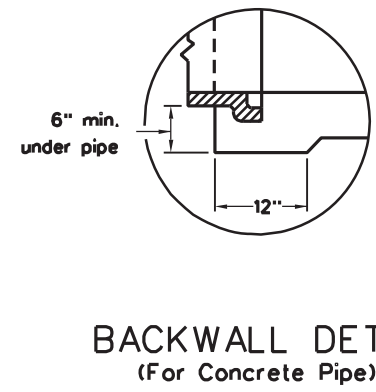
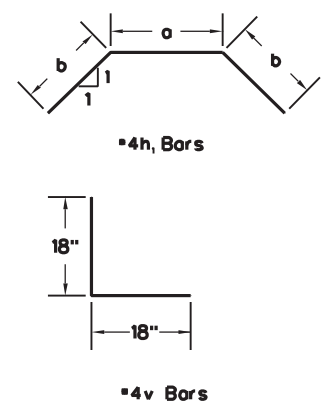
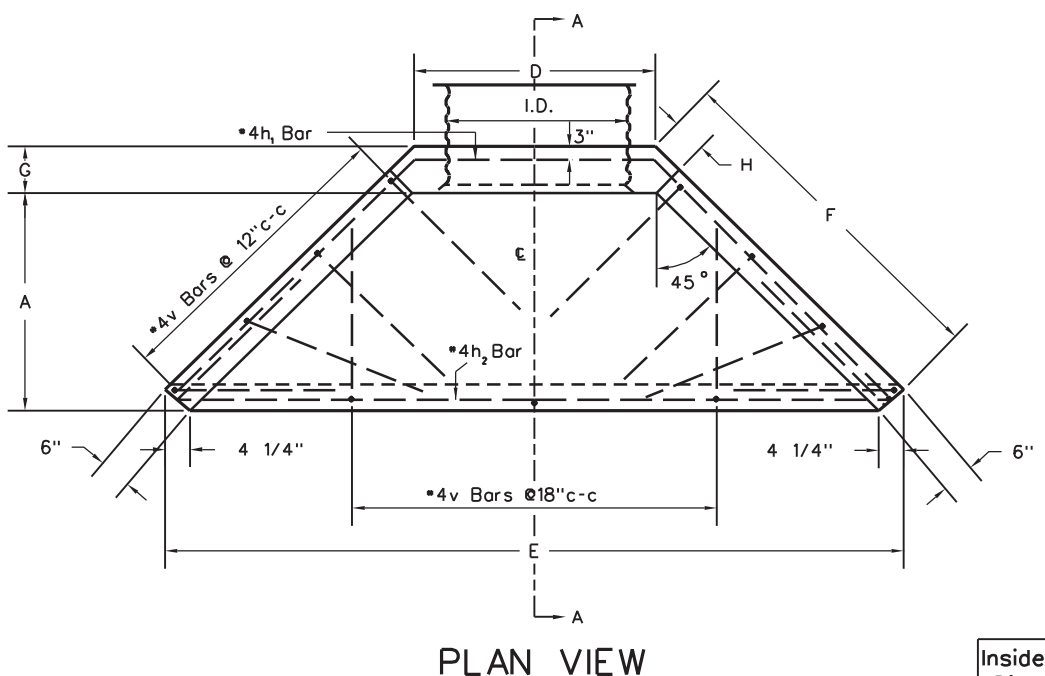

Inside Dia. of Pipe	Slope of Fill	DIMENSIONS								REINFORCEMENT					QUANTITIES				
		A	B	C	D	E	F	G	H	Mark	Size	No. of Bars	LENGTH		Type	CONC (R.C.P.) C.Y.	CONC (C.M.P.) C.Y.	STEEL LBS.	
15"	2:1	*2'-0"	0'-10"	1'-11"	2'-0"	6'-7 1/2"	3'-3 1/4"	*0'-8"	*0'-5 3/8"	h ₁	*4	2	1'-10"	3'-2 1/2"	8'-3"	BENT	0.61	0.62	41.2
		†2'-2"						†0'-6"	†0'-2 1/2"	h ₂	*4	1			6'-1"	ST.			
		BEVEL: DEPTH=3/4" LENGTH=1"								v	*4	13			3'-0"	BENT			
18"	2:1	*2'-0"	1'-1"	2'-2"	2'-3"	6'-10 1/2"	3'-3 1/4"	*0'-8"	*0'-5 3/8"	h ₁	*4	2	2'-1"	3'-2 1/2"	8'-6"	BENT	0.67	0.68	41.8
		†2'-2"						†0'-6"	†0'-2 1/2"	h ₂	*4	1			6'-4"	ST.			
		BEVEL: DEPTH=3/4" LENGTH=1 1/4"								v	*4	13			3'-0"	BENT			
24"	2:1	*2'-8"	1'-4"	2'-9"	2'-11"	8'-10 1/2"	4'-2 1/2"	*0'-8"	*0'-5 3/8"	h ₁	*4	2	2'-9"	4'-1 1/2"	11'-0"	BENT	1.01	1.02	52.4
		†2'-10"						†0'-6"	†0'-2 1/2"	h ₂	*4	1			8'-4"	ST.			
		BEVEL: DEPTH=1" LENGTH=1 1/2"								v	*4	16			3'-0"	BENT			
30"	2:1	*3'-1"	1'-7"	3'-3"	3'-5"	10'-4 1/2"	4'-11"	*0'-9"	*0'-6 3/4"	h ₁	*4	2	3'-3"	4'-10 1/2"	13'-0"	BENT	1.32	1.37	58.1
		†3'-4"						†0'-6"	†0'-2 1/2"	h ₂	*4	1			9'-10"	ST.			
		BEVEL: DEPTH=1 1/4" LENGTH=2"								v	*4	17			3'-0"	BENT			
36"	2:1	*3'-9"	1'-10"	3'-10"	4'-1"	12'-4 1/2"	5'-10 1/2"	*0'-9"	*0'-6 3/4"	h ₁	*4	2	3'-11"	5'-9 1/2"	15'-6"	BENT	1.79	1.86	70.8
		†4'-0"						†0'-6"	†0'-2 1/2"	h ₂	*4	1			11'-10"	ST.			
		BEVEL: DEPTH=1 1/2" LENGTH=2 1/4"								v	*4	21			3'-0"	BENT			

* DIMENSIONS FOR INLET WINGWALLS ON CORRUGATED METAL PIPE (TO ACCOMMODATE THE BEVEL).
 † DIMENSIONS FOR INLET WINGWALLS ON CONCRETE PIPE AND ALL OUTLET WINGWALLS.

WEST VIRGINIA DEPARTMENT OF TRANSPORTATION
 DIVISION OF HIGHWAYS
 STANDARD DETAIL

**PIPE CULVERT
 WINGWALLS
 (SHEET 1 OF 4)**

STANDARD SHEET DR2

PREPARED 7-1-99
 REVISION DATE

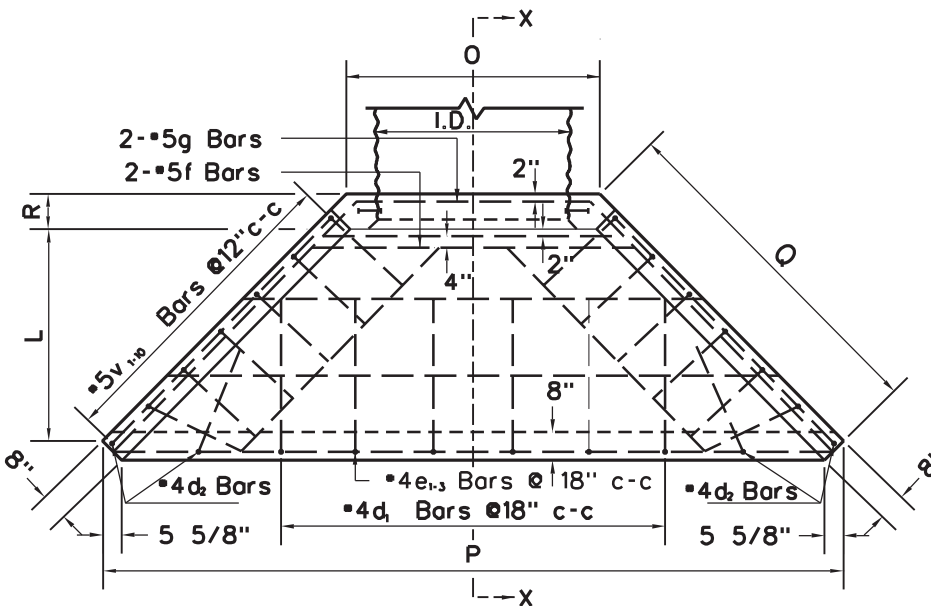

PLAN VIEW

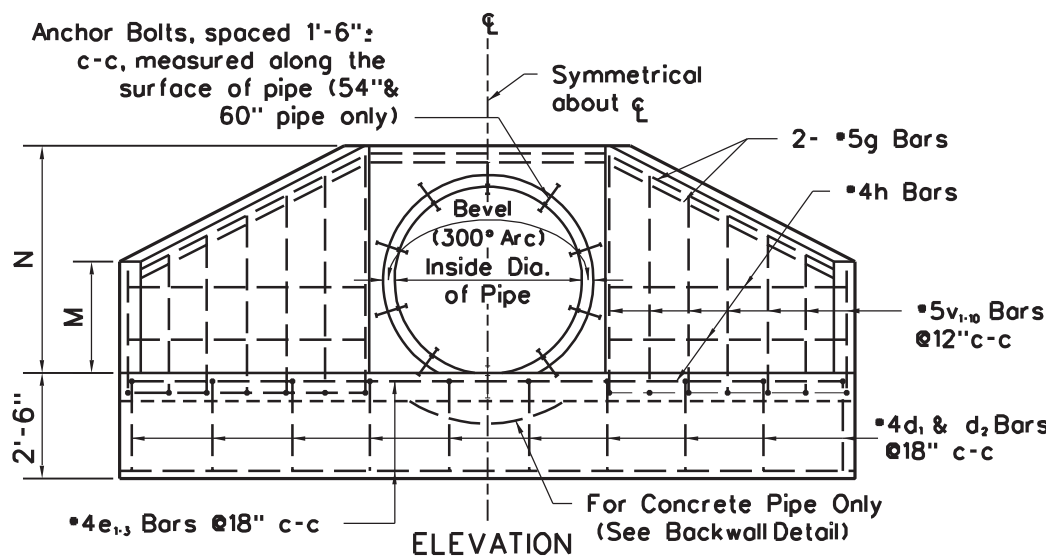

ELEVATION

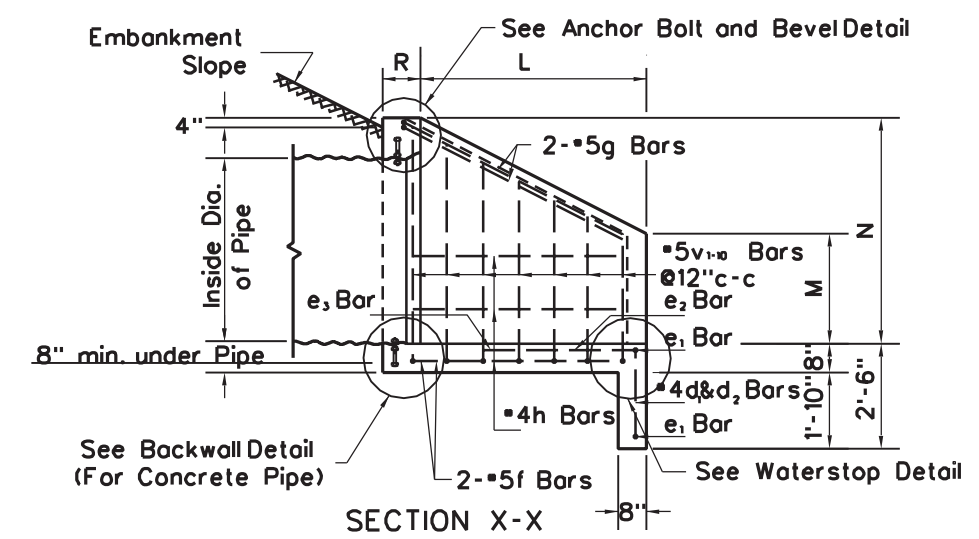

SECTION X-X

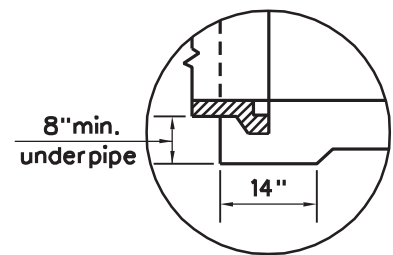

BACKWALL DETAIL (for concrete pipe)

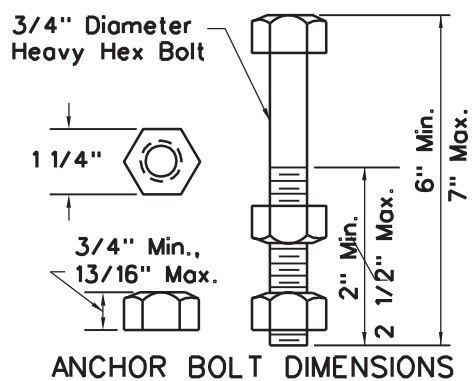

ANCHOR BOLT DIMENSIONS

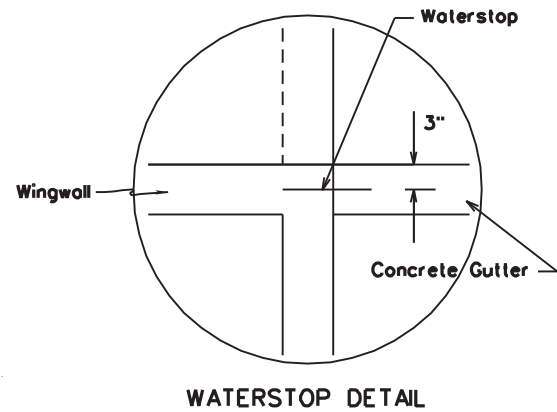

WATERSTOP DETAIL

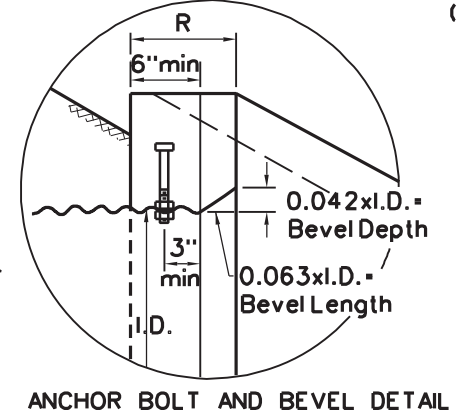

ANCHOR BOLT AND BEVEL DETAIL

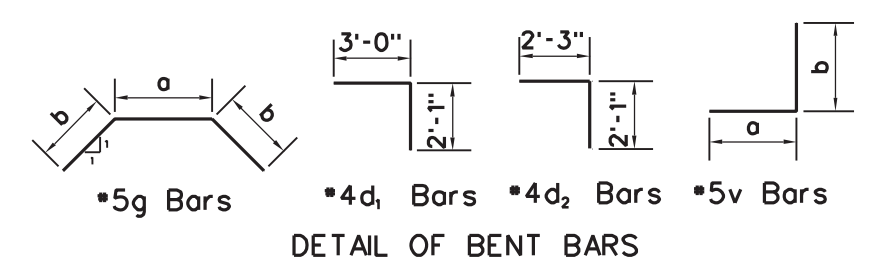

DETAIL OF BENT BARS

NOTES

The "Notes" and the "Construction Detail-Skewed Pipe" on Standard Sheet DR2 (Sheet 1 of 2) shall apply to this sheet.

Anchor bolts shall be used on wingwalls for corrugated metal and structural plate pipe greater than 48" in diameter. Anchor bolts are not required for concrete pipe.

Anchor bolts and nuts shall conform to the requirements for "Headwall Anchorage" hardware as stipulated in AASHTO Specification M-167. Anchor bolts and nuts shall be cleaned after galvanizing to provide a free running fit.

Cost of the anchor bolts and nuts shall be included in the unit price bid for the pipe.

Right-of-way fence hardware inserts shall be installed in the sidewalls during the construction of wingwalls for pipes over 48" in diameter. Dimensions and location of inserts shall conform to the "Drainage Structure Terminal Installation" detail of the applicable right-of-way fence standard.

Waterstop meeting the requirements of 708.10 shall be placed as shown when concrete gutter is to abut the wingwall.

Inside Dia. of Pipe	Slope of Fill	DIMENSIONS										REINFORCEMENT			QUANTITIES			Inside Dia. of Pipe	Slope of Fill	DIMENSIONS										REINFORCEMENT			QUANTITIES		
		L	M	N	O	P	Q	R	S	M	Size	No. of Bars	Length	Type	Conc. (RCP) C.Y.	Conc. (C.M.P. or S.P.P.) C.Y.	Steel Lbs.			L	M	N	O	P	Q	R	S	M	Size	No. of Bars	Length	Type	Conc. (RCP) C.Y.	Conc. (C.M.P. or S.P.P.) C.Y.	Steel Lbs.
42"	2:1	x 4'-3"	2'-2"	4'-4 1/2"	4'-10"	14'-1 1/2"	6'-6 1/2"	x 0'-10"	x 0'-6 1/2"	d1	#4	6	5'-1"	Bent	3.17	3.23	225.0	54"	2:1	x 5'-5"	2'-8"	5'-5 1/2"	6'-0"	17'-6 1/2"	8'-2"	x 0'-10"	x 0'-6 1/2"	d1	#4	8	5'-1"	Bent	4.64	4.74	300.0
		+4'-5"						+0'-8"	+0'-3 1/4"	d2	#4	4	4'-4"	Bent				60"	2:1	x 6'-0"	2'-11"	6'-0"	6'-7"	19'-3 1/2"	9'-0"	x 0'-10"	x 0'-6 1/2"	d1	#4	9	5'-1"	Bent	5.54	5.66	341.0
										e1	#4	2	13'-6"	St.														e2	#4	4	4'-4"	Bent			
										e2	#4	1	11'-0"	St.														e3	#4	1	17'-0"	St.			
										e3	#4	1	8'-0"	St.														e4	#4	1	14'-6"	St.			
										f	#5	2	5'-10"	St.														e5	#4	1	11'-6"	St.			
										g	#5	2	4'-4"	Bent														f	#5	2	7'-0"	St.			
										h	#4	8	6'-0"	St.														g	#5	2	5'-6"	Bent			
										v1	#5	2	2'-0"	Bent														h	#4	8	7'-8"	St.			
										v2	#5	2	2'-0"	Bent														v1	#5	2	2'-0"	Bent			
										v3	#5	2	2'-0"	Bent														v2	#5	2	2'-0"	Bent			
										v4	#5	2	2'-0"	Bent														v3	#5	2	2'-0"	Bent			
										v5	#5	2	2'-0"	Bent														v4	#5	2	2'-0"	Bent			
										v6	#5	2	2'-0"	Bent														v5	#5	2	2'-0"	Bent			
										v7	#5	2	2'-0"	Bent														v6	#5	2	2'-0"	Bent			
										v8	#5	2	2'-0"	Bent														v7	#5	2	2'-0"	Bent			

* Dimensions for inlet wingwalls on corrugated metal or structural plate pipe (to accommodate bevel).
 + Dimensions for inlet wingwalls on concrete pipe and all outlet wingwalls.

WEST VIRGINIA DEPARTMENT OF TRANSPORTATION
 DIVISION OF HIGHWAYS
 STANDARD DETAIL

PIPE CULVERT
 WINGWALLS
 (SHEET 2 OF 4)

PREPARED 7-1-99
 REVISION DATE

STANDARD SHEET DR2

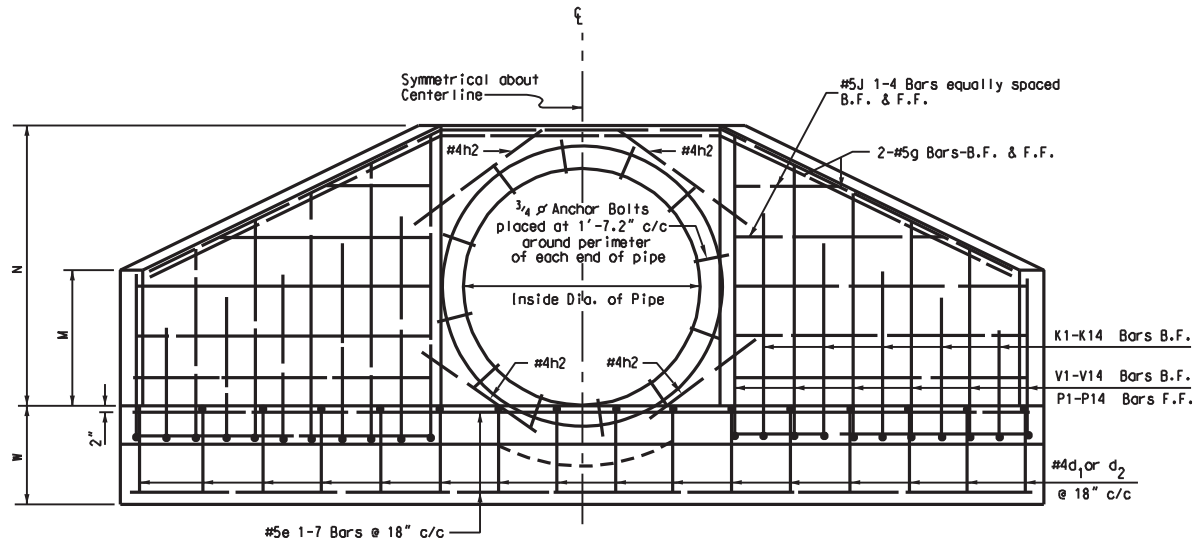

END VIEW

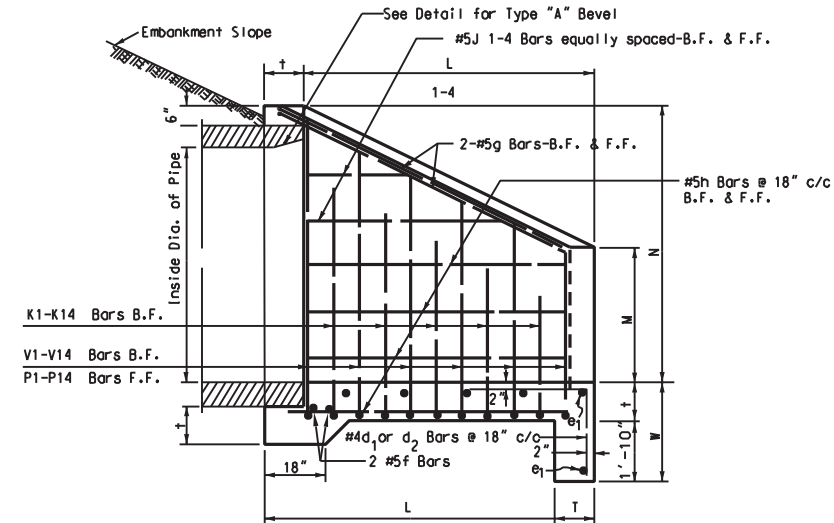

SECTION X-X

NOTES
REINFORCING BAR DETAILS AND QUANTITIES ARE SHOWN ON SHEET 4 OF 4
B.F. DENOTES BACK FACE
F.F. DENOTES FRONT FACE

INSIDE DIA OF PIPE	SLOPE OF FILL	DIMENSIONS									
		L	M	N	O	P	Q	t	u	w	
72"	2:1	7'-4"	3'-6"	7'-1"	8'-0"	23'-3"	10'-9"	12"	8 1/2"	2'-10"	
84"	2:1	8'-6"	4'-0"	8'-2"	9'-2"	26'-9"	12'-5"	12"	8 1/2"	2'-10"	
96"	2:1	9'-8"	4'-6"	9'-3"	10'-4"	30'-3"	14'-1"	12"	8 1/2"	2'-10"	
108"	2:1	10'-10"	5'-0"	10'-4"	11'-6"	33'-9"	15'-9"	12"	8 1/2"	2'-10"	
120"	2:1	12'-0"	5'-6"	11'-5"	12'-8"	37'-4"	17'-5"	14"	9 1/8"	3'-0"	
144"	2:1	14'-4"	6'-6"	13'-6"	14'-10"	44'-3"	20'-9"	16"	11 1/8"	3'-2"	

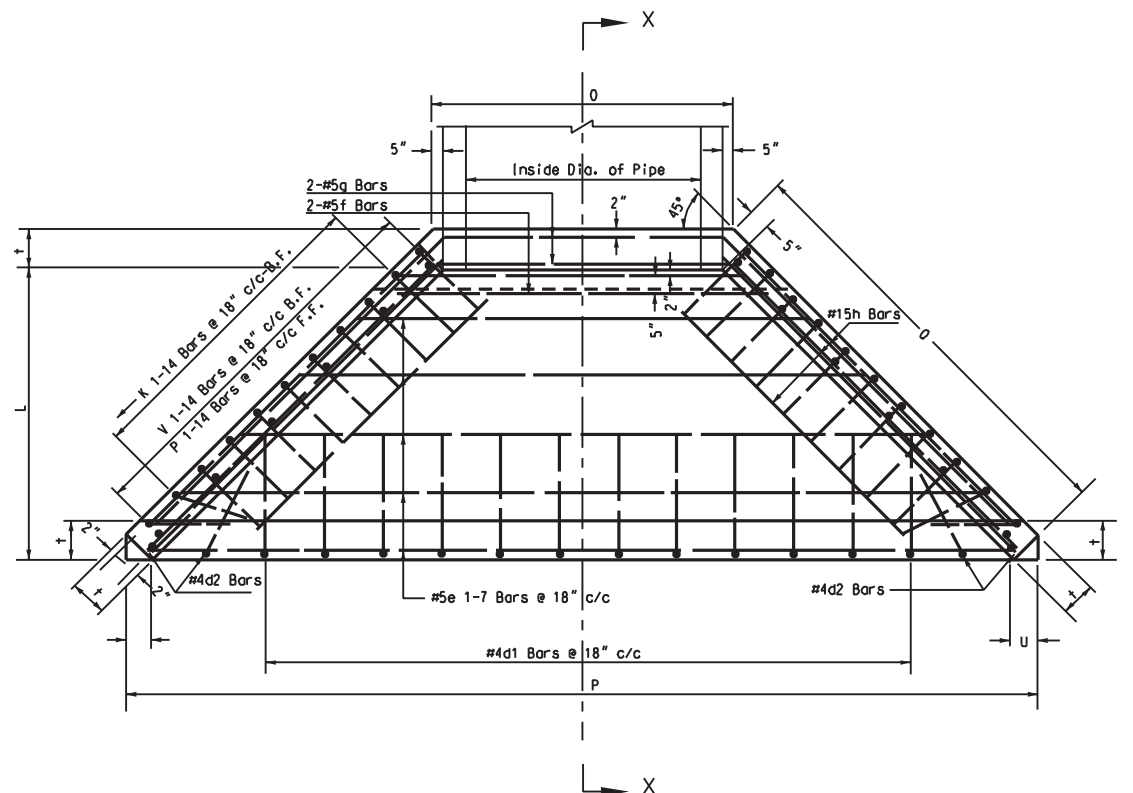

PLAN

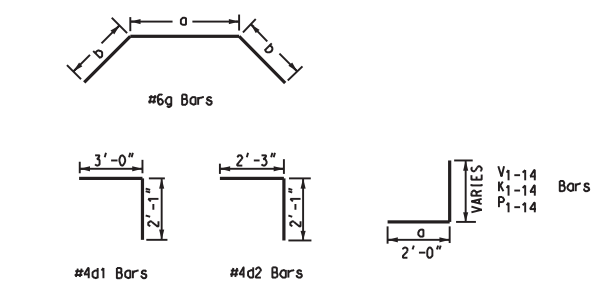

DETAIL OF BENT BARS

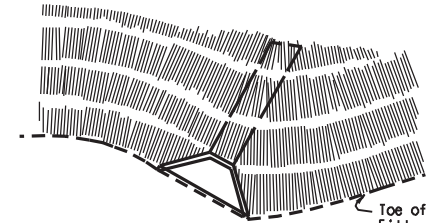

SKEWED PIPE CONSTRUCTION DETAIL

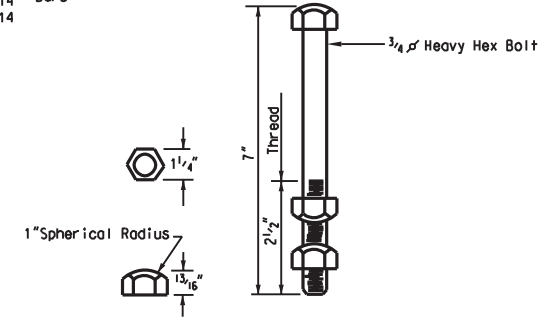
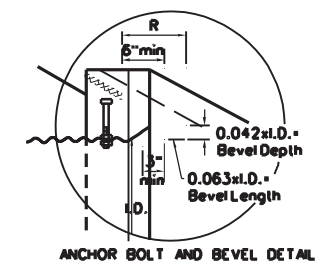
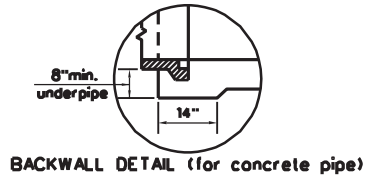

ANCHOR BOLT DETAIL

NOTES
NOTES ON THE STANDARD DETAIL DR2 (SHEETS 1 OF 2 AND 2 OF 2) SHALL APPLY TO THIS SHEET.

WEST VIRGINIA DEPARTMENT OF TRANSPORTATION
DIVISION OF HIGHWAYS
STANDARD DETAIL

PREPARED 7/1/99
REVISION DATE

PIPE CULVERT
WINGWALLS
(SHEET 3 OF 4)

STANDARD SHEET DR2

DIMENSIONS OF GALVANIZED STEEL END SECTION FOR ROUND PIPE								
PIPE DIAM. (INCHES)	METAL THK. (INCHES)	DIMENSIONS (INCHES)					APPROX. SLOPE	BODY
		A ± 1"	B MAX	H ± 1"	L ± 1 1/2"	W ± 2"		
12	.064	6	6	6	21	24	2 1/2	1 PC.
15	.064	7	8	6	26	30	2 1/2	1 PC.
18	.064	8	10	6	31	36	2 1/2	1 PC.
21	.064	9	12	6	36	42	2 1/2	1 PC.
24	.064	10	13	6	41	48	2 1/2	1 PC.
30	.079	12	16	8	51	60	2 1/2	1 PC.
36	.079	14	19	9	60	72	2 1/2	2 PC.
42	.109	16	22	11	69	84	2 1/2	2 PC.
48	.109	18	27	12	78	90	2 1/4	2 PC.
54	.109	18	30	12	84	102	2	2 PC.
60	.109	18	33	12	87	114	1 3/4	3 PC.
66	.109	18	36	12	87	120	1 1/2	3 PC.
72	.109	18	39	12	87	126	1 1/3	3 PC.
78	.109	18	42	12	87	132	1 1/4	3 PC.
84	.109	18	45	12	87	138	1 1/6	3 PC.

DIMENSIONS OF GALVANIZED STEEL END SECTION FOR PIPE ARCH										
PIPE ARCH SPAN X RISE (INCHES)	EQUIV. DIAM. (INCHES)	METAL THK. (INCHES)	DIMENSIONS (INCHES)					APPROX. SLOPE	BODY	
			A ± 1"	B MAX	H ± 1"	L ± 1 1/2"	W ± 2"			
17X13	15	.064	7	9	6	19	30	2 1/2	1 PC.	
21X15	18	.064	7	10	6	23	36	2 1/2	1 PC.	
24X18	21	.064	8	12	6	28	42	2 1/2	1 PC.	
28X20	24	.064	9	14	6	32	48	2 1/2	1 PC.	
35X24	30	.079	10	16	6	39	60	2 1/2	1 PC.	
42X29 (40X31)	36	.079	12	18	8	46	75	2 1/2	1 PC.	
49X33 (46X36)	42	.109	13	21	9	53	85	2 1/2	2 PC.	
57X38 (53X41)	48	.109	18	26	12	63	90	2 1/2	2 PC.	
64X43 (60X46)	54	.109	18	30	12	70	102	2 1/4	2 PC.	
71X47 (66X51)	60	.109	18	33	12	77	114	2 1/4	3 PC.	
77X52 (73X55)	66	.109	18	36	12	77	126	2	3 PC.	
83X57 (81X59)	72	.109	18	39	12	77	138	2	3 PC.	

NOTE: SPAN AND RISE DIMENSIONS IN PARENTHESES ARE FOR 3"X1" CORRUGATED PIPE ARCHES; ALL OTHER SPAN AND RISE VALUES ARE FOR 2 1/2"X1/2" CORRUGATED PIPE ARCHES.

NOTES

TYPICAL END SECTIONS FOR PIPES AND PIPE ARCHES ARE DETAILED HEREIN. OTHER SIMILAR DESIGNS MAY BE USED IF ACCEPTABLE TO THE ENGINEER.

GALVANIZED STEEL END SECTIONS SHALL BE USED ON THE ENDS OF CORRUGATED STEEL PIPES AND/OR PIPE ARCHES AT THOSE LOCATIONS SPECIFIED ON THE PLANS. END SECTIONS SHALL BE MEASURED AS THE NUMBER OF UNITS INSTALLED OF EACH SIZE AND TYPE AND SHALL BE PAID FOR IN ACCORDANCE WITH 604 OF THE SPECIFICATIONS.

TWO-PIECE AND THREE-PIECE END SECTIONS SHALL BE OF LAP SEAM CONSTRUCTION, TIGHTLY JOINED WITH 3/8" DIAMETER GALVANIZED RIVETS OR BOLTS.

FOR 60" THRU 84" PIPES, THE REINFORCED EDGES OF THE END SECTIONS SHALL BE SUPPLEMENTED WITH GALVANIZED STIFFENER ANGLES FASTENED BY 3/8" DIAMETER GALVANIZED BOLTS AND NUTS. THIS REQUIREMENT SHALL ALSO BE APPLICABLE TO THE END SECTIONS FOR 77"X52", 73"X 55", 83"X 57", AND 81"X 59" PIPE ARCH SIZES. IN ADDITION, FOR THOSE PIPE ARCH SIZES, ANGLE REINFORCEMENT SHALL BE USED UNDER THE CENTER PANEL SEAMS.

THE END SECTION CONNECTION DETAILS SHALL BE AS SHOWN ON THIS PLAN SHEET OR OF A SIMILAR DESIGN AS RECOMMENDED BY THE MANUFACTURER. ALL SIMILAR DESIGNS SHALL PROVIDE A SECURE ATTACHMENT OF THE END SECTION TO THE PIPE OR PIPE ARCH.

ALTHOUGH A PIPE OR PIPE ARCH MAY HAVE A BITUMINOUS COATING AND/OR PAVED INVERT, IT WILL NOT BE NECESSARY TO BITUMINOUS COAT OR PAVE THE END SECTION, CONNECTORS, OR CONNECTOR SECTION.

TOE PLATE EXTENSIONS SHALL BE THE SAME THICKNESS AS THE END SECTIONS AND SHALL BE FASTENED TO TOE PLATES WITH 3/8" DIAMETER GALVANIZED BOLTS. LENGTH OF TOE PLATE EXTENSION SHALL BE W+10"(approx.) FOR 12" THRU 30" DIAMETER PIPES AND FOR PIPE ARCHES WITH RISE VALUES UP TO AND INCLUDING 29". THE LENGTH SHALL BE W+22"(approx.) FOR LARGER PIPE SIZES AND W+18" (approx.) FOR LARGER PIPE ARCHES.

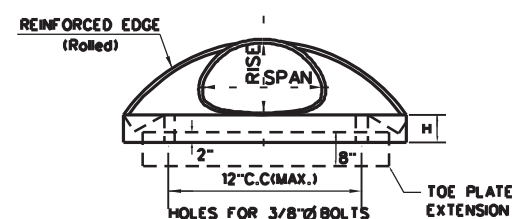
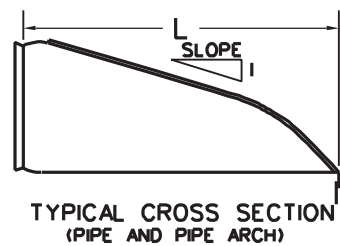
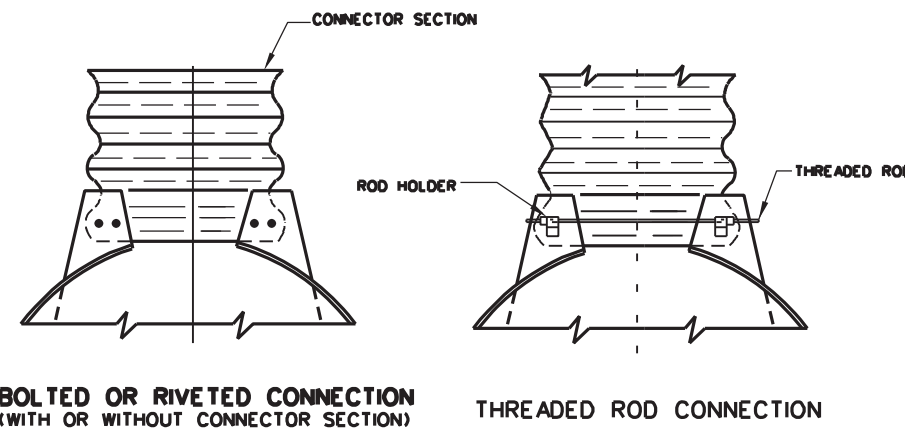
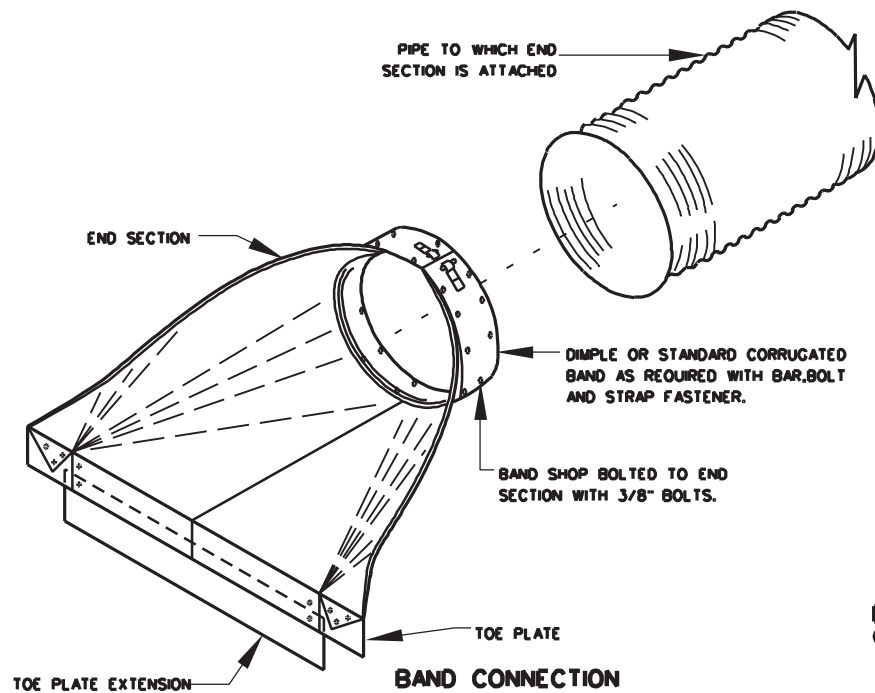

ELEVATION (PIPE ARCH)

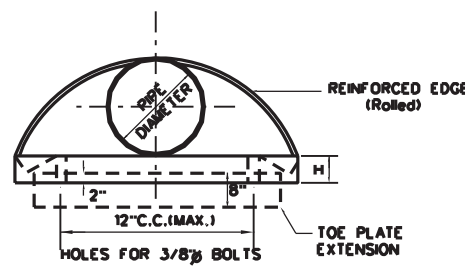

ELEVATION (PIPE)

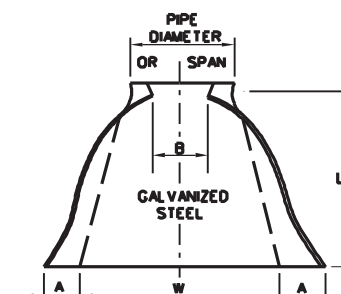

PLAN (PIPE AND PIPE ARCH)

WEST VIRGINIA DEPARTMENT OF TRANSPORTATION
DIVISION OF HIGHWAYS
STANDARD DETAIL

PREPARED 7-1-99
REVISION DATE

END SECTIONS FOR
CORRUGATED
STEEL PIPES AND PIPE
ARCHES

STANDARD SHEET DR3

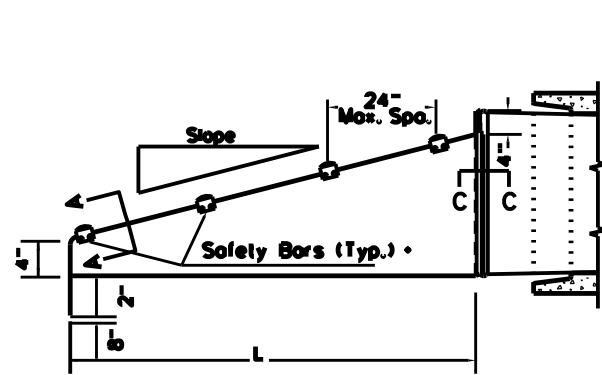

SIDE ELEVATION OF PARALLEL DRAINAGE STRUCTURE

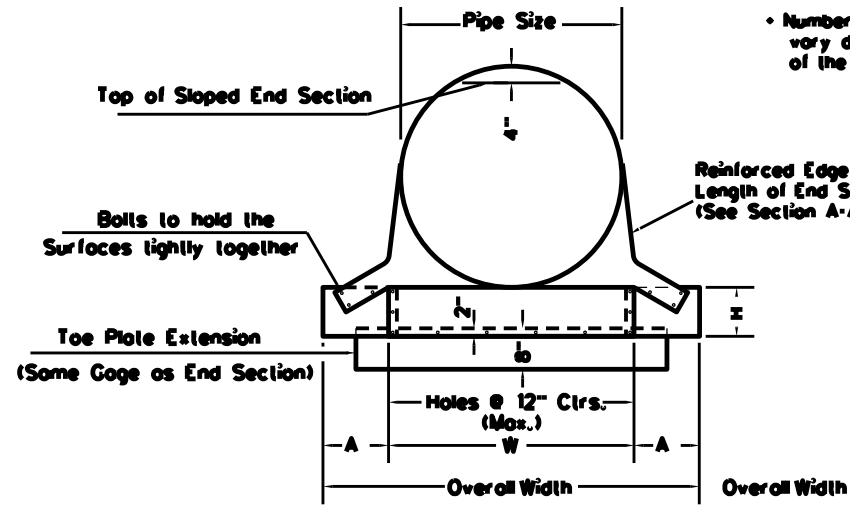

FRONT VIEW

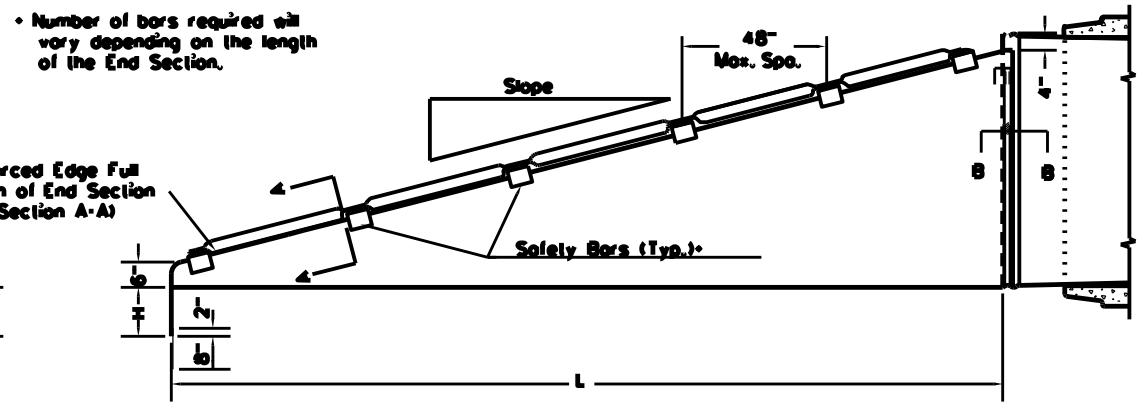

SIDE ELEVATION FOR CROSS DRAINAGE STRUCTURE

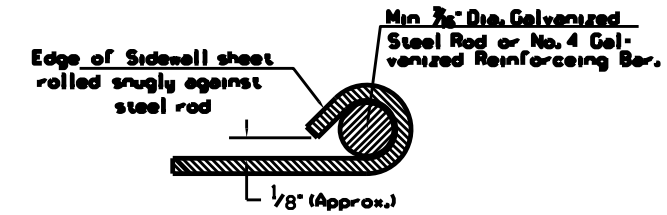

SECTION A-A

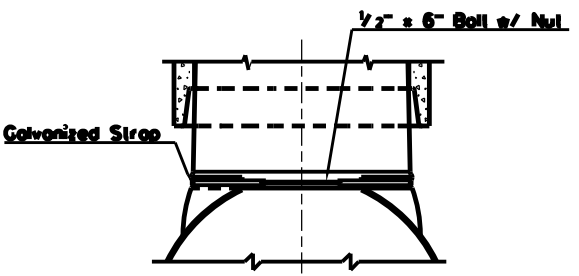

**SECTION C-C
TYPE #1 CONNECTOR DETAIL
Thru 24"**

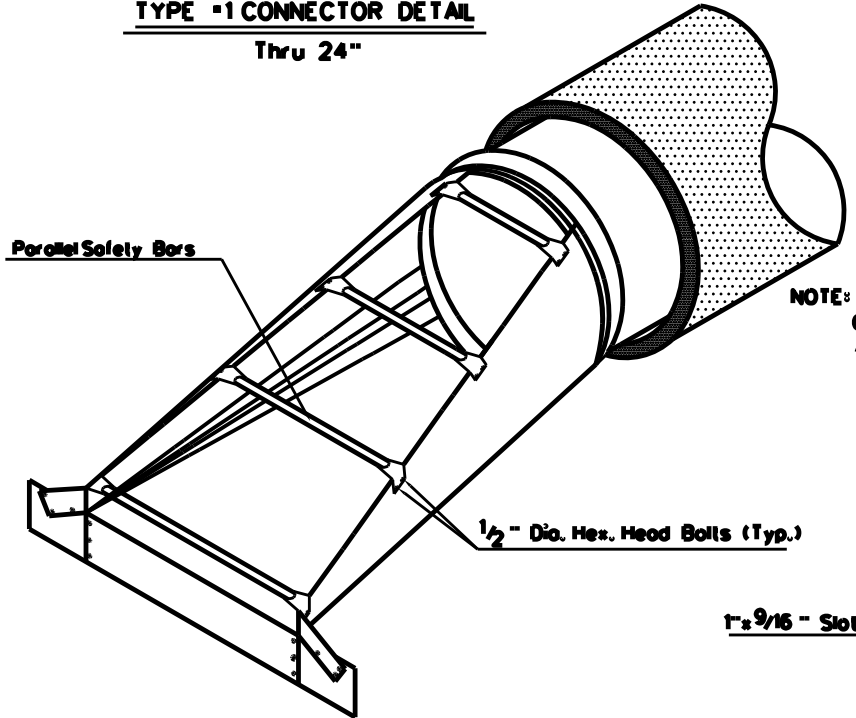

24" PARALLEL DRAINAGE STRUCTURE

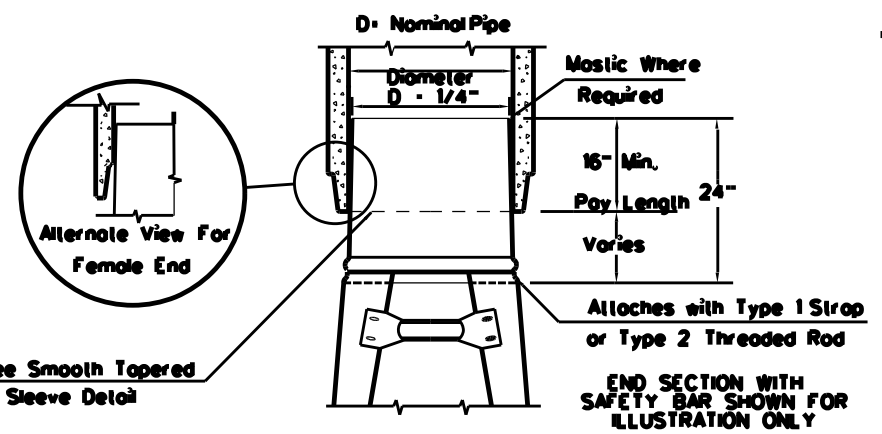

**TAPERED SLEEVE FOR ATTACHING
STEEL END SECTIONS TO CONCRETE PIPE**

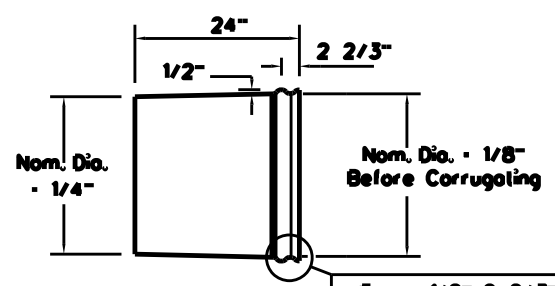

SMOOTH TAPERED SLEEVE DETAIL

NOTE: Metal to be 12 Gage Smooth Galvanized in Accordance with AASHTO M218.

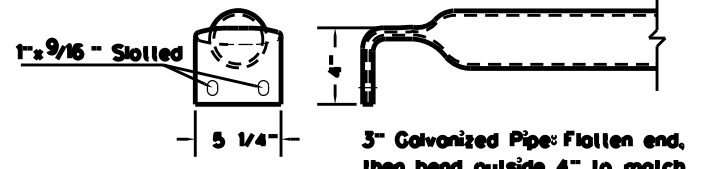

**PARALLEL BARS
DETAIL OF SAFETY BARS**

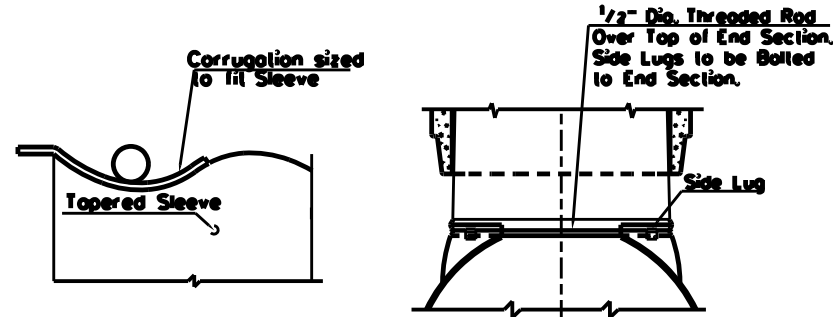

SECTION B-B

**TYPE #2 CONNECTOR DETAILS
For 30" and Larger**

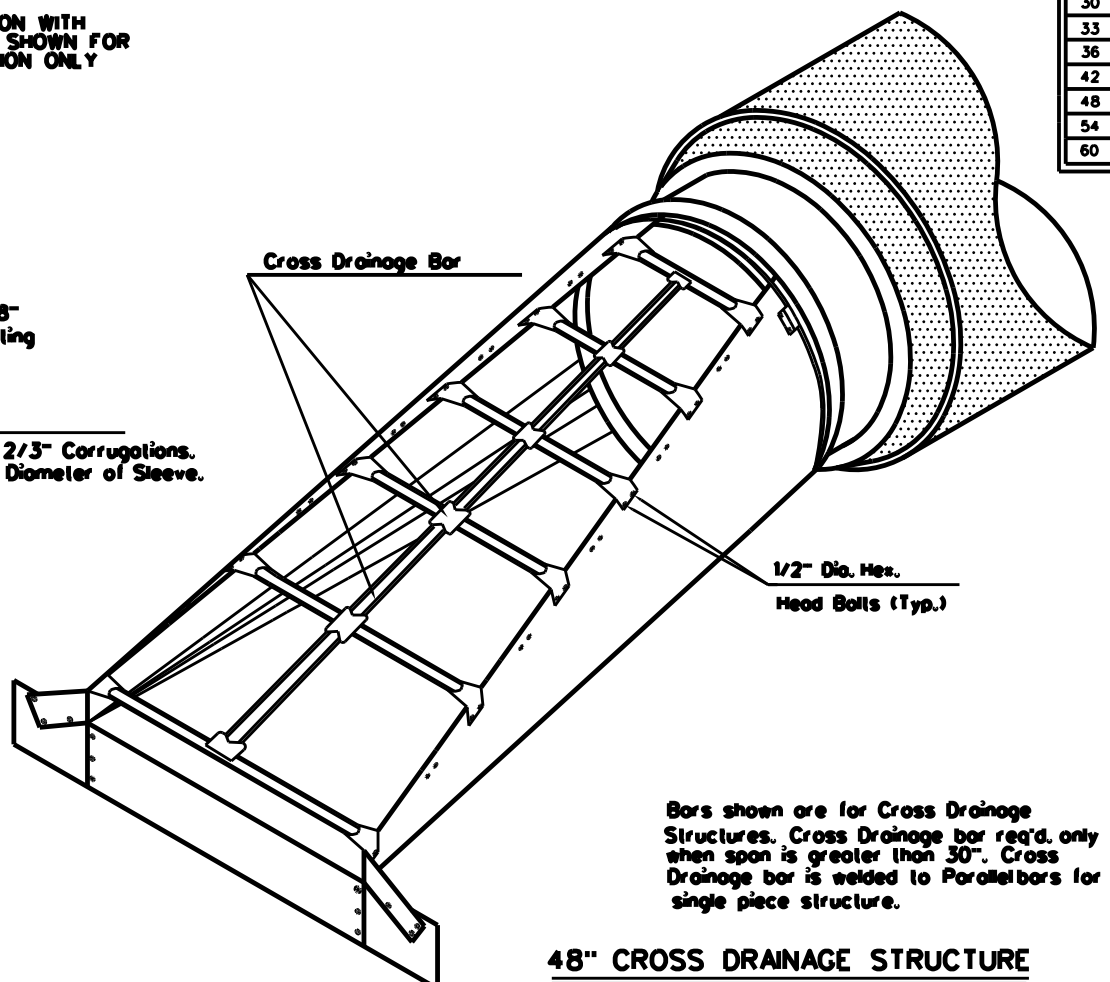

48" CROSS DRAINAGE STRUCTURE

Bars shown are for Cross Drainage Structures. Cross Drainage bar req'd. only when span is greater than 30". Cross Drainage bar is welded to Parallel bars for single piece structure.

NOTES

All notes on Standard Sheet DR3 are applicable to this Standard Sheet.
Slotted holes for safety bar attachment shall be provided for all end sections.
Safety bars shall be Schedule 40 Galvanized Steel Pipe conforming to ASTM A 53. Pipe to be galvanized after forming.

Pipe Dia. (In.)	Min. Thick. (In.)	Dimensions (Inches)				L Dimensions				
		Gage	A	H	W	Overall Width	Slope	Length (In.)	Slope	Length (In.)
15	.064	16	8	6	21	37	4:1	20	6:1	30
18	.064	16	8	6	24	40	4:1	32	6:1	48
21	.064	16	8	6	27	43	4:1	44	6:1	66
24	.064	16	8	6	30	46	4:1	56	6:1	84
27	.109	12	12	9	33	57	4:1	68	6:1	102
30	.109	12	12	9	36	60	4:1	80	6:1	120
33	.109	12	12	9	36	63	4:1	92	6:1	138
36	.109	12	12	9	42	66	4:1	104	6:1	156
42	.109	12	16	12	48	80	4:1	128	6:1	192
48	.109	12	16	12	54	86	4:1	152	6:1	228
54	.109	12	16	12	60	92	4:1	176	6:1	264
60	.109	12	16	12	66	98	4:1	200	6:1	300

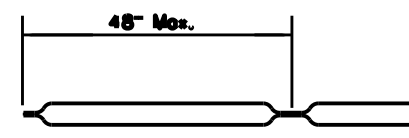

**CROSS DRAINAGE BAR
DETAIL OF SAFETY BARS**

WEST VIRGINIA DEPARTMENT OF TRANSPORTATION
DIVISION OF HIGHWAYS
STANDARD DETAIL

PREPARED 7-1-99
REVISION DATE
8-6-2020
6-17-2021

**SAFETY SLOPE END SECTION
FOR
CONCRETE PIPE**

STANDARD DRAWING DR 4
SHEET 1 OF 3

CONCRETE TO BE 3200 PSI MINIMUM COMPRESSIVE STRENGTH AT 28 DAYS. ALL REINFORCING STEEL TO CONFORM TO THE REQUIREMENTS OF 709.1 AND 709.4 OF THE SPECIFICATIONS. THE COST OF CONCRETE, STEEL REINFORCING, ALL OTHER REQUIRED ITEMS, SUCH AS, GASKET, GROUT, BEDDING, BACKFILL MATERIAL, PLACEMENT, ETC. IS INCLUDED IN THE COST OF THE CONCRETE PIPE SAFETY SLOPE END SECTION.

Inside Pipe Diameter	See Drawing For Dimensions Below					Wall Thickness	Slope
	A	B	C	D	E		
Inches	Inches						
12	3.75 - 8.75	23 - 27.25	45.5 - 52	69.5 - 77	23.5 - 24	2 - 2.75	2.2:1 - 3:1
15	5.5 - 11	26.5 - 27.75	42.75 - 49.5	69.5 - 77	30 - 32	2.25 - 5.5	1.5:1 - 3:1
18	9 - 14.5	25 - 29.25	42.25 - 49.5	69 - 76.5	35.75 - 36	2.5 - 5.75	1.5:1 - 3:1
21	9 - 11	33 - 35	38 - 42	73 - 77	42	2.75	2.2:1 - 3:1
24	9.5 - 16	43 - 44	25.75 - 36.5	69.25 - 78.5	47.5 - 48	3 - 6.5	2:1 - 3:1
27	10.5	48	25.5	73.5 - 77.5	54	3.25	2.4:1 - 3:1
30	9.5 - 19.25	53.75 - 54	15 - 21	69 - 77.75	59.5 - 60	3.5 - 6.75	1.9:1 - 3:1
33	13 - 21	59 - 60	39 - 40	94.5 - 98	66	3.75	2.4:1 - 3:1
36	15 - 23.5	62.5 - 64	23.25 - 36.75	92.5 - 99.75	69.75 - 72	4 - 4.75	2:1 - 3:1
42	20.5 - 21	62.5 - 63	34 - 39	97.5 - 101.5	77.25 - 78	4.5 - 4.75	2.4:1 - 3:1
48	24 - 24.75	71.75 - 72	26 - 26.75	97 - 98.5	81.75 - 84	5	2.4:1 - 3:1
54	27	65	35	100	90	5.5	1.9:1 - 2:1
60	30	60	39	99	96	6	1.6:1 - 2:1
66	36	78	21	99	102	6.25	2:1
72	34 - 42	78	21	99	108	7	1.7:1 - 2:1

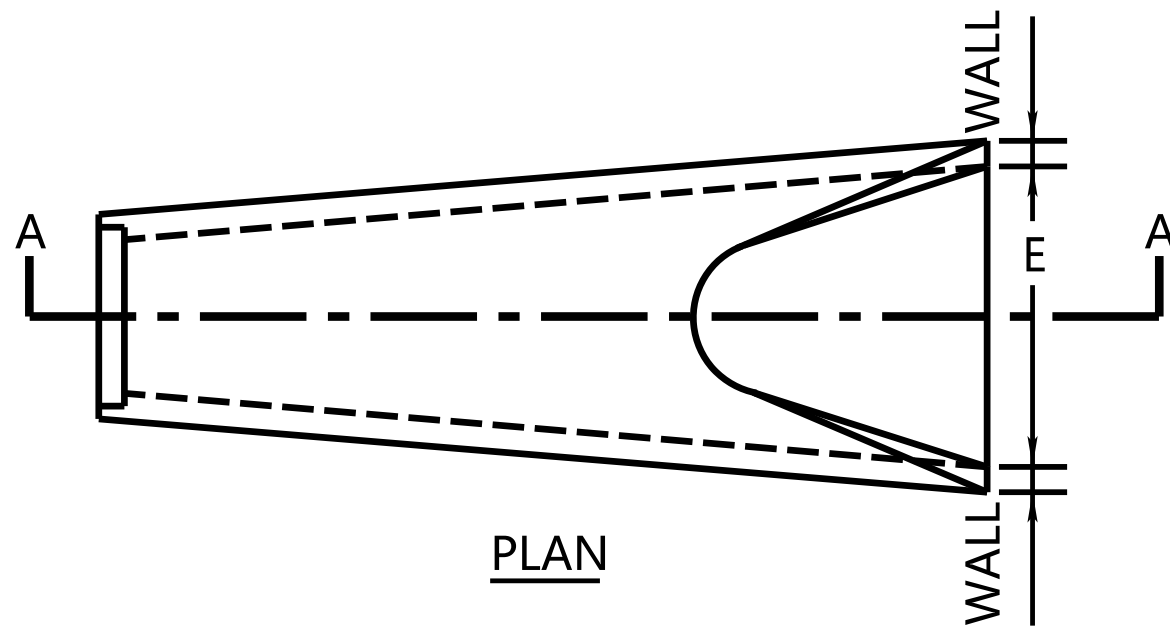

PLAN

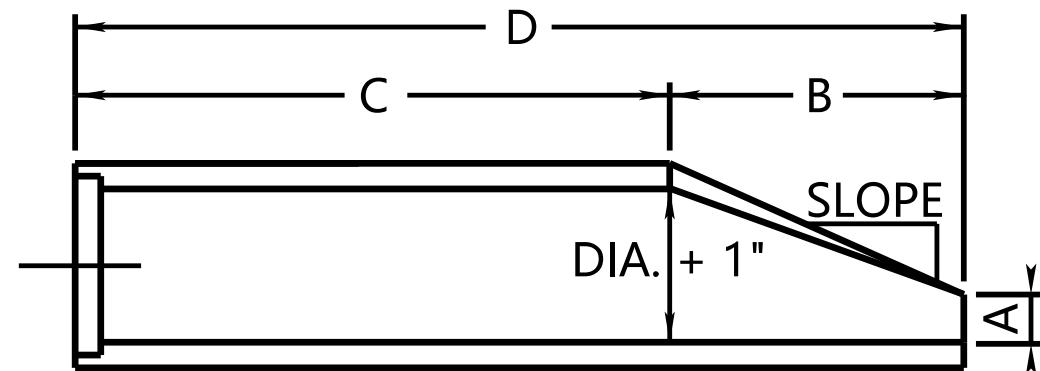

SECTION A-A

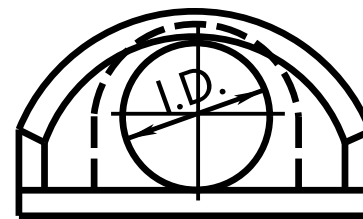

FRONT VIEW

WEST VIRGINIA DEPARTMENT OF TRANSPORTATION
DIVISION OF HIGHWAYS
STANDARD DETAIL

PREPARED 08/04/2020
REVISION DATE
06/17/2021

CONCRETE PIPE SAFETY SLOPE END SECTION

STANDARD DETAIL DRAWING DR 4
SHEET 2 of 3

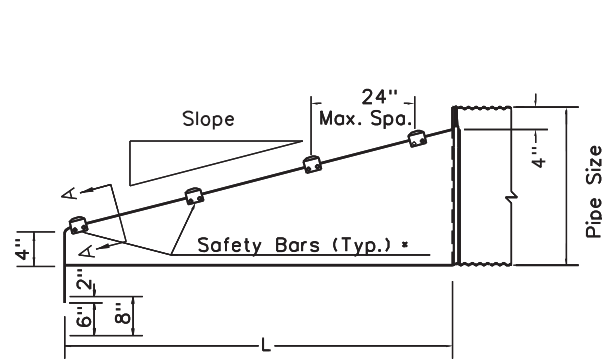

SIDE ELEVATION OF PARALLEL DRAINAGE STRUCTURE

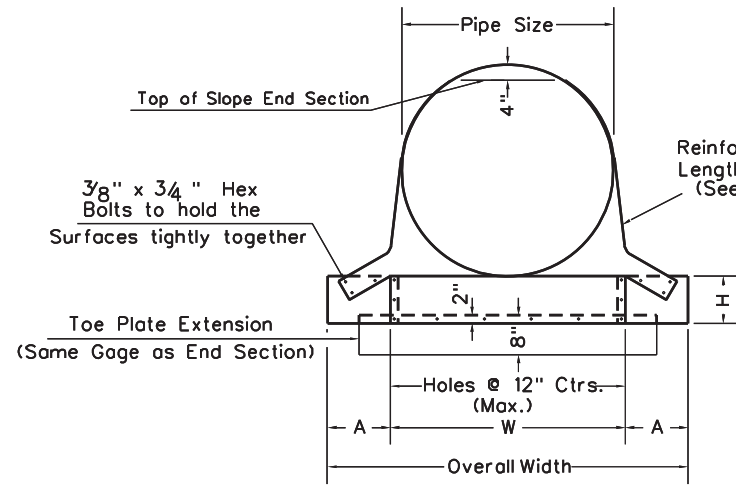

FRONT VIEW

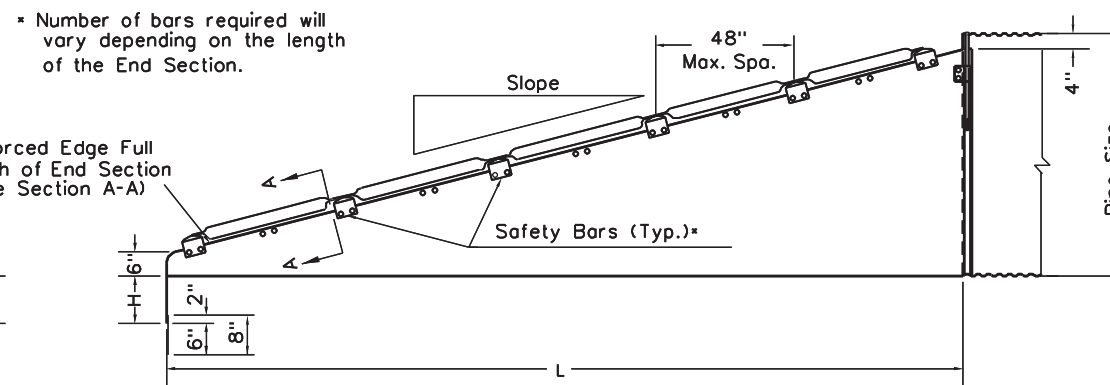

SIDE ELEVATION FOR CROSS DRAINAGE STRUCTURE

* Number of bars required will vary depending on the length of the End Section.

NOTES

All notes on Standard Sheet DR3 are applicable to this Standard Sheet.

Slotted holes for safety bar attachment shall be provided for all end sections.

Safety bars shall be Schedule 40 Galvanized Steel Pipe conforming to ASTM A 53. Pipe to be galvanized after forming.

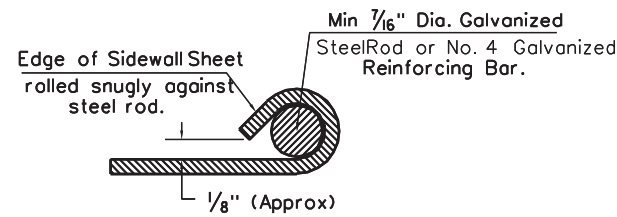

SECTION A-A

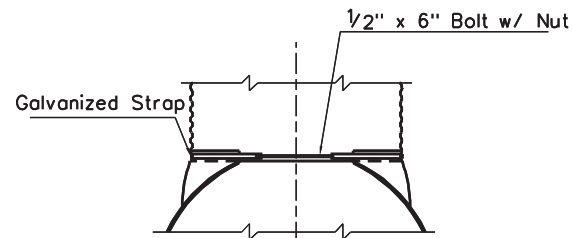

TYPE #1 CONNECTOR DETAIL
Thru 24"

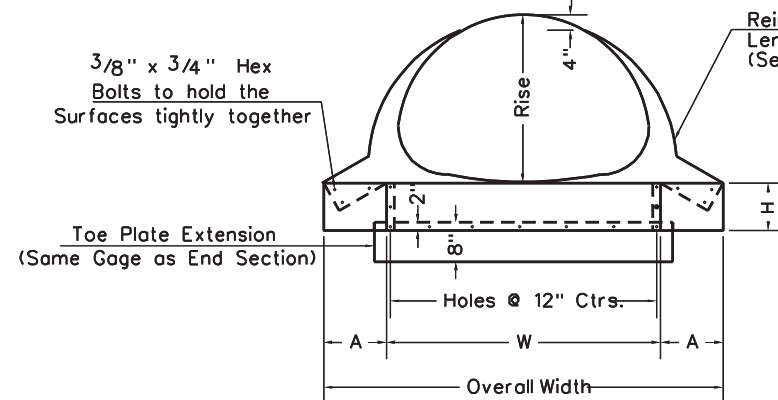

FRONT VIEW

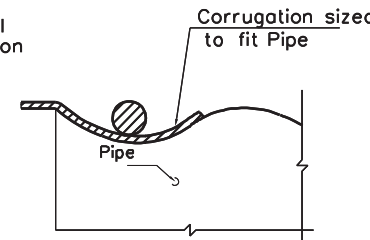

SECTION B-B

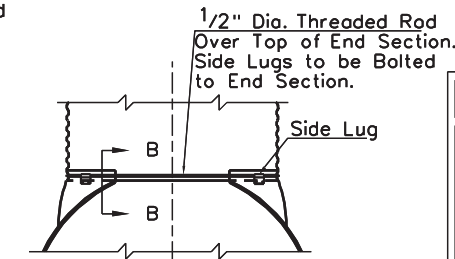

TYPE #2 CONNECTOR DETAILS
For 30" and Larger
21"x15" and Larger

METAL END SECTIONS FOR CIRCULAR PIPES										
Pipe Dia. (In.)	Min. Thick. In.	Gage	Dimensions (Inches)				L Dimensions			
			A	H	W	Overall Width	Slope	Length (In.)	Slope	Length (In.)
15	.064	16	8	6	21	37	4:1	20	6:1	30
18	.064	16	8	6	24	40	4:1	32	6:1	48
21	.064	16	8	6	27	43	4:1	44	6:1	66
24	.064	16	8	6	30	46	4:1	56	6:1	84
30	.109	12	12	9	36	60	4:1	80	6:1	120
36	.109	12	12	9	42	66	4:1	104	6:1	156
42	.109	12	16	12	48	80	4:1	128	6:1	192
48	.109	12	16	12	54	86	4:1	152	6:1	228
54	.109	12	16	12	60	92	4:1	176	6:1	264
60	.109	12	16	12	66	98	4:1	200	6:1	300

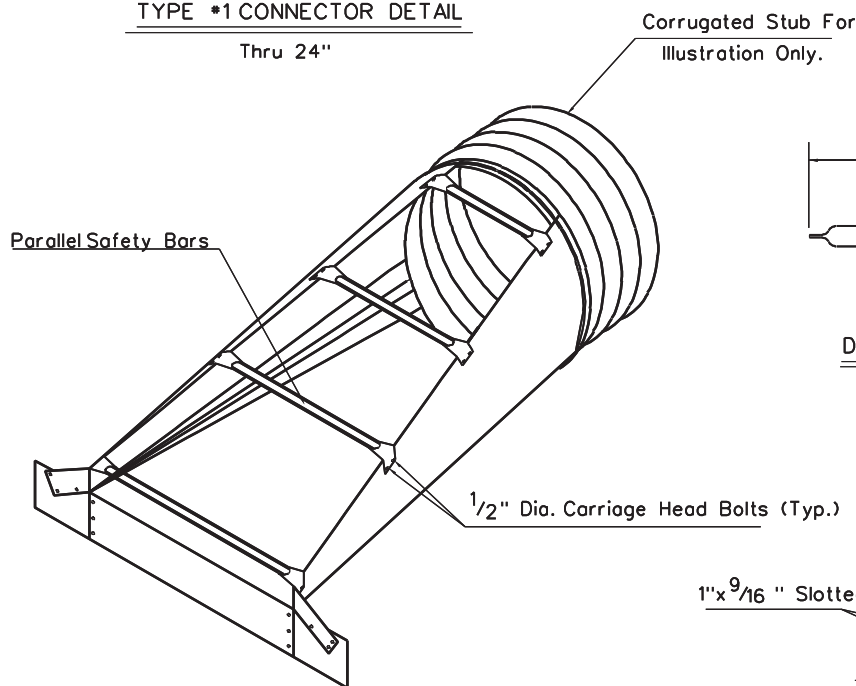

24" PARALLEL DRAINAGE STRUCTURE

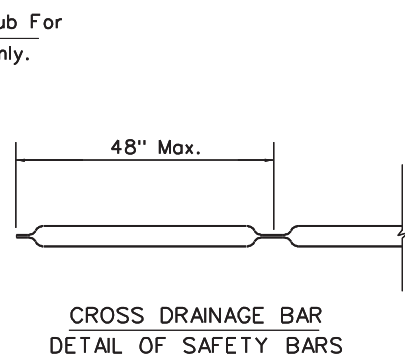

CROSS DRAINAGE BAR
DETAIL OF SAFETY BARS

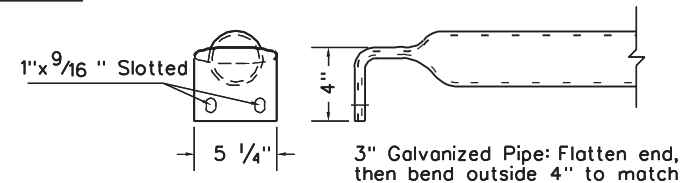

PARALLEL BARS
DETAIL OF SAFETY BARS

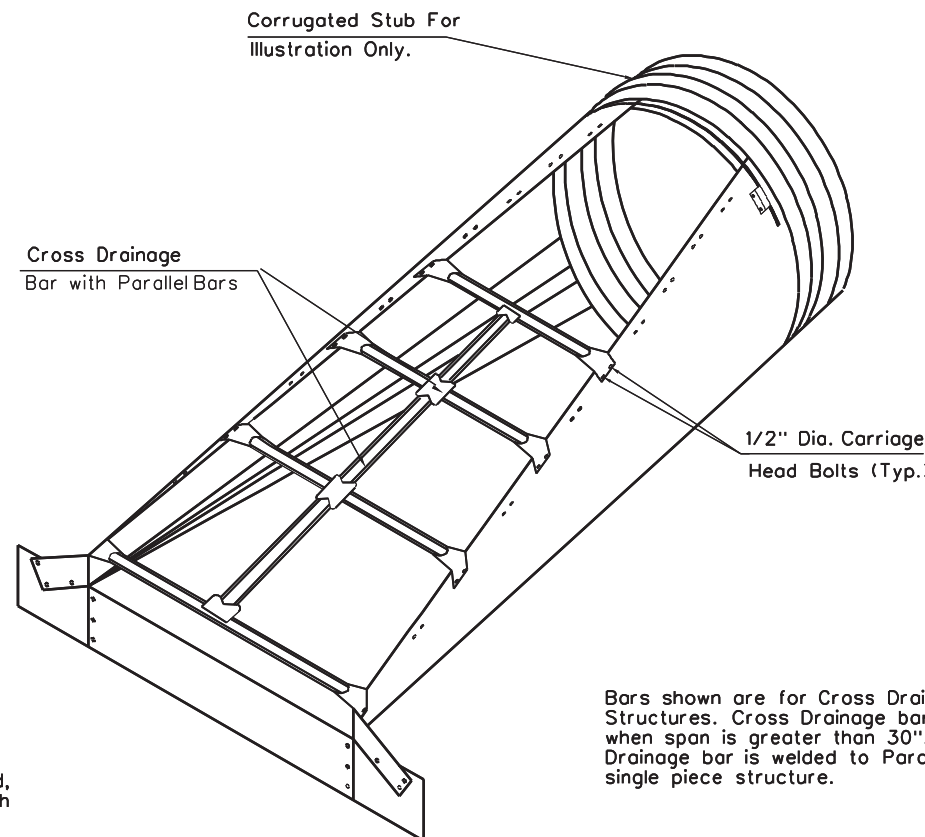

CROSS DRAINAGE STRUCTURE

Bars shown are for Cross Drainage Structures. Cross Drainage bar req'd. when span is greater than 30". Cross Drainage bar is welded to Parallelbars for single piece structure.

METAL END SECTIONS FOR ARCHED PIPES												
Eqv. Dia. (In.)	(Inches)		Min. Thick. In.	Gage	Dimensions (Inches)				L Dimensions			
	Span	Rise			A	H	W	Overall Width	Slope	Length (In.)	Slope	Length (In.)
18	21	15	.064	16	8	6	27	43	4:1	20	6:1	30
21	24	18	.064	16	8	6	30	46	4:1	32	6:1	48
24	28	20	.064	16	8	6	34	50	4:1	40	6:1	60
30	35	24	.079	14	12	9	41	65	4:1	56	6:1	84
36	42	29	.109	12	12	9	48	72	4:1	76	6:1	114
42	49	33	.109	12	16	12	55	87	4:1	92	6:1	138
48	57	38	.109	12	16	12	63	95	4:1	112	6:1	168
54	64	43	.109	12	16	12	70	102	4:1	132	6:1	198
60	71	47	.109	12	16	12	77	109	4:1	148	6:1	222
72	83	57	.109	12	16	12	89	121	4:1	188	6:1	282

WEST VIRGINIA DEPARTMENT OF TRANSPORTATION
DIVISION OF HIGHWAYS
STANDARD DETAIL

PREPARED 7-1-99

REVISION DATE

SAFETY SLOPE END SECTION
FOR
CIRCULAR & ARCHED
STEEL PIPES

STANDARD SHEET DR5

NOTES

THIS INLET SHOULD ONLY BE SPECIFIED WHEN ABUTTING CONCRETE PAVEMENT

THE FINAL INSTALLED TOP SURFACE OF INLET AND GRATE SHALL BE FLUSH WITH ADJACENT FINISHED SURFACES SUCH AS PAVEMENT, GUTTERS, CURBS, AND SIDEWALKS. TOP OF GRATE ELEVATION, IF SHOWN ON THE PLANS, IS FOR INFORMATION ONLY.

CONSTRUCTION MAY BE CAST-IN-PLACE, PRECAST IN ONE OR MULTIPLE SECTIONS, OR ANY COMBINATION OF CAST-IN-PLACE AND PRECAST.

REBARS ARE TO BE INSTALLED AT THE THIRD POINTS TO CONNECT CURB TO INLET. REBARS ARE NOT REQUIRED IF CURB IS POURED MONOLITHICALLY WITH INLET OR IF TYPE V OR VI MEDIAN IS SPECIFIED ON THE PLANS.

FOR DETAILS OF GRATE SUPPORT BAR, SHALLOW FRAME, AND GRATES (TWO REQUIRED), SEE INLET CASTINGS STANDARD SHEET DR6-X. USE OF THE SHALLOW FRAME WILL BE LIMITED TO ROADWAYS CONSTRUCTED OF CONCRETE PAVEMENT. IF ADJACENT ROADWAY IS BUILT OF HOT MIX ASPHALT PAVEMENT, THE FRAME AS REQUIRED FOR A TYPE F INLET (STANDARD SHEET DR6F) WILL BE REQUIRED.

THE CONTRACTOR MAY, AT HIS OPTION, OMIT USE OF THE FRAME BY FORMING A LEDGE IN THE CONCRETE.

SPECIAL CARE SHALL BE EXERCISED IN FORMING THE 2" WIDE CONCRETE LEDGE TO PROVIDE A SMOOTH, EVEN SURFACE FOR SUPPORTING THE GRATES IF THE SHALLOW FRAME IS NOT USED. NO PROJECTIONS SHALL EXIST ON THE BEARING SURFACES OF THE LEDGE OR THE GRATES, AND THE GRATES SHALL SEAT ON THE LEDGE WITHOUT ROCKING.

OPTIONAL CONSTRUCTION JOINTS LABELED "CJ" MAY BE ROUGHENED CONCRETE, KEYED OR DOWELED AS PER THE TYPICAL DETAILS SHOWN HEREIN OR AS APPROVED BY THE ENGINEER. NON SHRINK GROUT MEETING THE REQUIREMENTS OF SUBSECTION 715.5 OF THE SPECIFICATIONS MAY BE USED TO A DEPTH OF 1/2" FOR LEVELING BETWEEN PRECAST SECTIONS. THICKER DEPTHS WILL BE ALLOWED IF AS PER THE MANUFACTURER'S RECOMMENDATIONS.

PC (MINIMUM PIPE COVER) SHALL BE 12" BELOW INLET TOP FOR PIPES PLACED UNDER SIDEWALK OR GRASSED AREA OR 24" BELOW INLET TOP FOR PIPES PLACED UNDER PAVEMENT OR SHOULDER.

CURB, IF SPECIFIED, MAY BE EITHER CONCRETE PLACED ON THE INLET BACKWALL AS DETAILED HEREIN OR AN APPROVED CURB BOX AS MANUFACTURED WITH THE GRATE AND FRAME. DIMENSIONS OF THE CURB BOX SHOULD REASONABLY CONFORM TO THE STANDARD CURB AS SPECIFIED ON THE PLANS. THE CURB WILL BE PAID FOR PER SECTION 610, IN EITHER CASE

THIS INLET SHALL NOT BE PLACED IN A PEDESTRIAN CROSS WALK.

THE MINIMUM DISTANCE FROM THE TOP OF ANY PIPE OPENING TO ANY CONSTRUCTION JOINT ABOVE THE OPENING SHALL BE FOUR (4) INCHES.

THE NUMBER AND LOCATION OF PIPE OPENINGS SHALL BE AS SHOWN IN THE PLANS. THE CONTRACTOR AT NO ADDITIONAL COST, SHALL BE RESPONSIBLE FOR ANY TEMPORARY BRACING REQUIRED TO TRANSPORT PRECAST INLET SECTIONS DUE TO MULTIPLE OPENINGS.

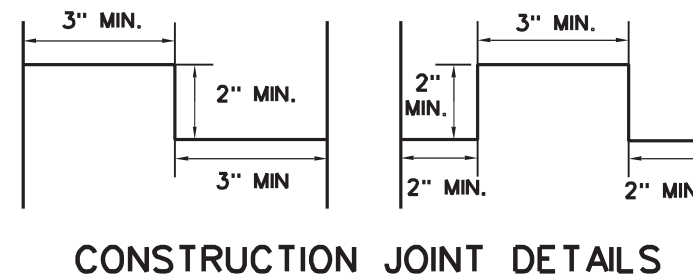
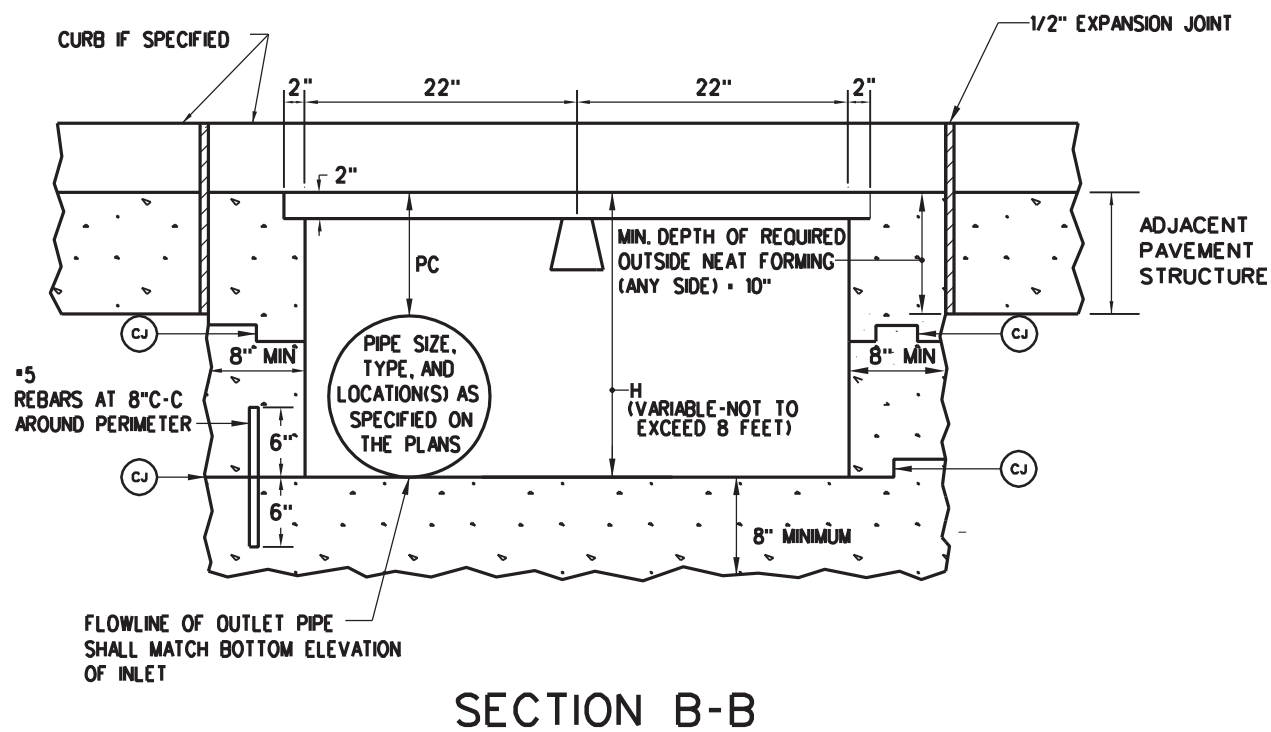
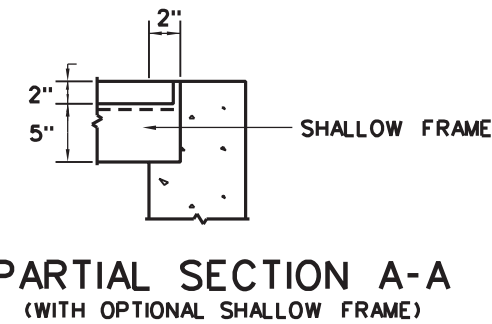
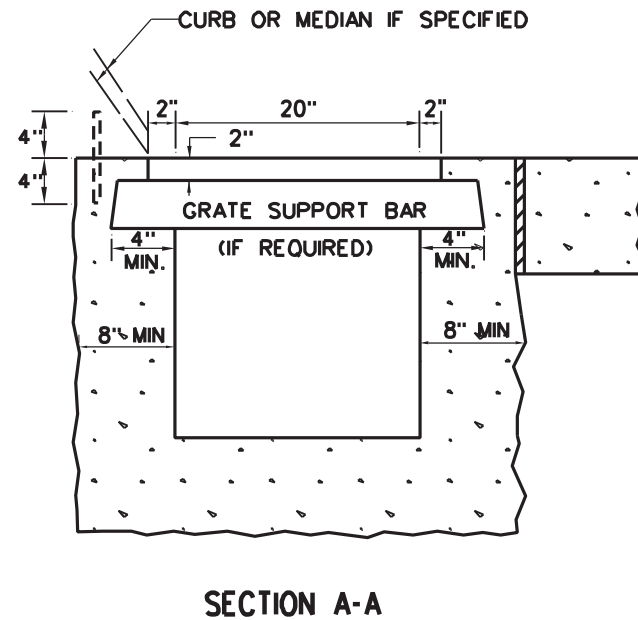
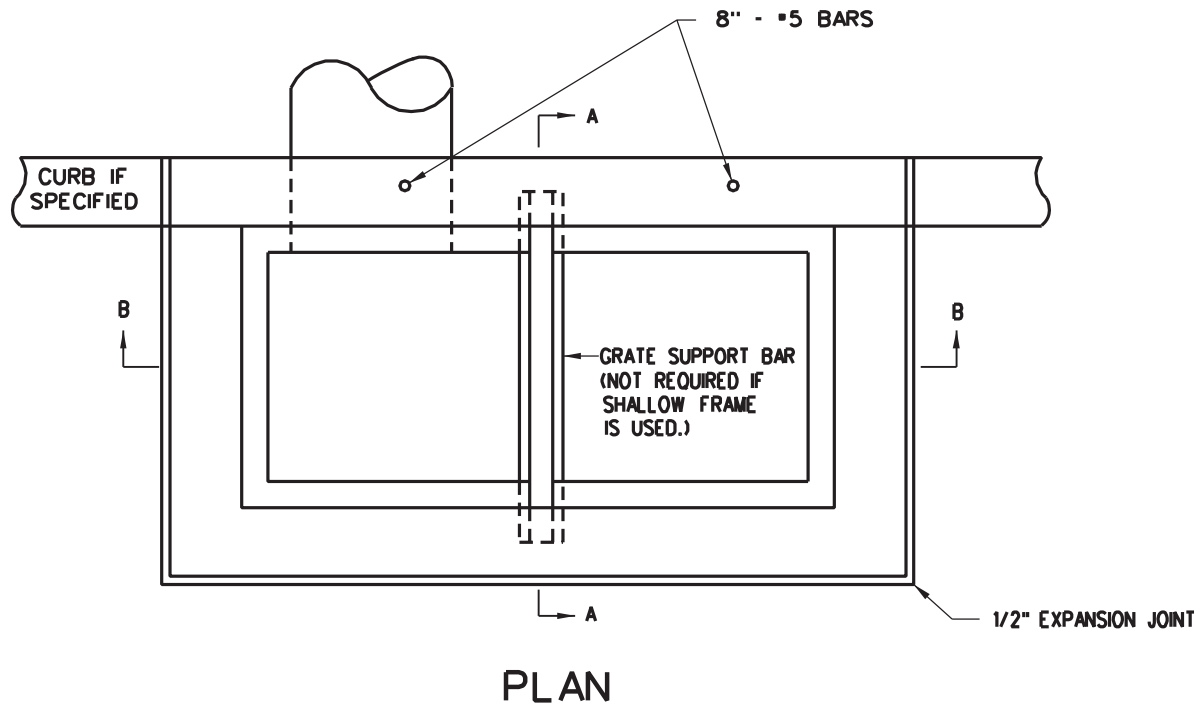

WEST VIRGINIA DEPARTMENT OF TRANSPORTATION
DIVISION OF HIGHWAYS
STANDARD DETAIL

PREPARED 7-1-99
REVISION DATE

TYPE A INLET

STANDARD SHEET DR6-A

NOTES

UNLESS OTHERWISE SPECIFIED ON THE PLANS, TYPE B INLETS MAY BE CONSTRUCTED IN ANY OF THE SHAPES SHOWN WHEN THE OUTLET PIPE DIAMETERS IS 21" OR LESS AND THE ADJACENT PAVEMENT IS CONCRETE.

IF THE OUTLET PIPE DIAMETER IS 24" OR THE ADJACENT PAVEMENT IS HOT MIX ASPHALT, ONLY THE SQUARE STYLE WITH THE DEEP FRAME WILL BE USED. THE INSIDE OPENING OF THE INLET WILL BE ADJUSTED TO ACCOMODATE THE 24" PIPE.

CONSTRUCTION MAY BE CAST-IN-PLACE, PRECAST IN ONE OR MULTIPLE SECTIONS, OR ANY COMBINATION OF CAST-IN-PLACE AND PRECAST.

OPTIONAL CONSTRUCTION JOINTS LABELED "CJ" MAY BE ROUGHENED CONCRETE, KEYED OR DOWELED AS PER THE TYPICAL DETAILS SHOWN HEREIN, OR AS APPROVED BY THE ENGINEER. NON SHRINK GROUT MEETING THE REQUIREMENTS OF SUBSECTION 715.5 OF THE SPECIFICATIONS MAY BE USED TO A DEPTH OF 1/2" FOR LEVELING BETWEEN PRECAST SECTIONS. THICKER DEPTHS WILL BE ALLOWED AS PER THE MANUFACTURER'S RECOMMENDATIONS.

THE FINAL INSTALLED TOP SURFACE OF INLET AND GRATE SHALL BE FLUSH WITH ADJACENT FINISHED SURFACES SUCH AS PAVEMENT, GUTTERS, CURBS, AND SIDEWALKS. TOP OF GRATE ELEVATION, IF SHOWN ON THE PLANS, IS FOR INFORMATION ONLY.

REBARS ARE TO BE INSTALLED AT THE QUARTER POINTS TO CONNECT CURB TO INLET. REBARS ARE NOT REQUIRED IF CURB IS POURED MONOLITHICALLY WITH THE INLET OR IF TYPE V OR VIMEDIAN IS SPECIFIED ON THE PLANS.

FOR DETAILS OF GRATES AND FRAMES, SEE INLET CASTING STANDARD SHEET DR6-X.

THE CONTRACTOR MAY, AT HIS OPTION, OMIT USE OF THE SHALLOW FRAME BY FORMING A LEDGE IN THE CONCRETE.

SPECIAL CARE SHALL BE EXERCISED IN FORMING THE 2" WIDE CONCRETE LEDGE TO PROVIDE A SMOOTH, EVEN SURFACE FOR SUPPORTING THE GRATE IF A FRAME IS NOT USED. NO PROJECTIONS SHALL EXIST ON THE GRATE AND THE GRATE SHALL SEAT ON THE LEDGE WITHOUT ROCKING.

FIBRE FORM SHALL BE REMOVED PRIOR TO COMPLETION OF THE PROJECT.

PC (MINIMUM PIPE COVER) SHALL BE 12" BELOW INLET TOP FOR PIPES PLACED UNDER SIDEWALK OR GRASSED AREA OR 24" BELOW INLET TOP FOR PIPES PLACED UNDER PAVEMENT OR SHOULDER.

CURB, IF SPECIFIED, MAY BE EITHER CONCRETE PLACED ON THE INLET BACKWALL AS DETAILED HEREIN OR AN APPROVED CURB BOX AS MANUFACTURED WITH THE GRATE AND FRAME. DIMENSIONS OF THE CURB BOX SHOULD REASONABLY CONFORM TO THE STANDARD CURB AS SPECIFIED ON THE PLANS. THE CURB WILL BE PAID FOR PER SECTION 610, IN EITHER CASE.

THIS INLET SHALL NOT BE PLACED IN A PEDESTRIAN CROSS WALK.

THE MINIMUM DISTANCE FROM THE TOP OF ANY PIPE OPENING TO ANY CONSTRUCTION JOINT ABOVE THE OPENING SHALL BE FOUR (4) INCHES.

THE NUMBER AND LOCATION OF PIPE OPENINGS SHALL BE AS SHOWN IN THE PLANS. THE CONTRACTOR AT NO ADDITIONAL COST, SHALL BE RESPONSIBLE FOR ANY TEMPORARY BRACING REQUIRED TO TRANSPORT PRECAST INLET SECTIONS DUE TO MULTIPLE OPENINGS.

SQUARE STYLE

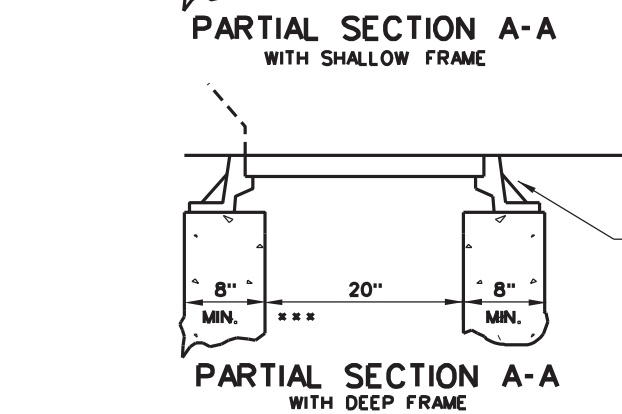
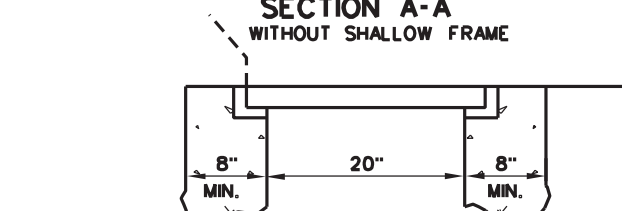
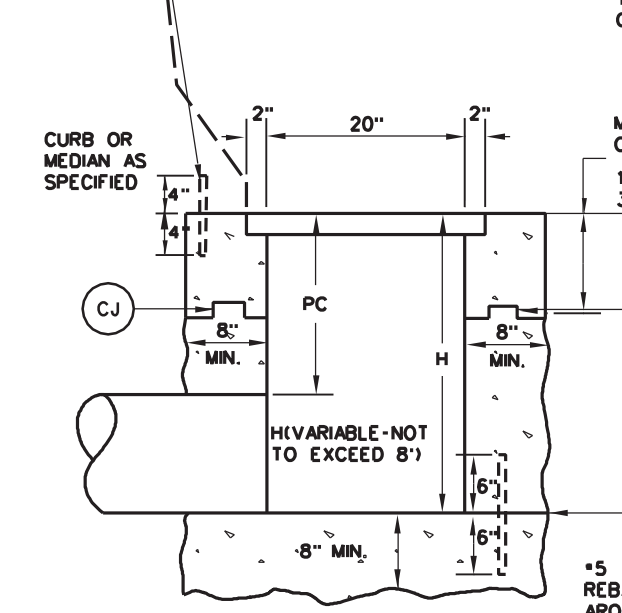
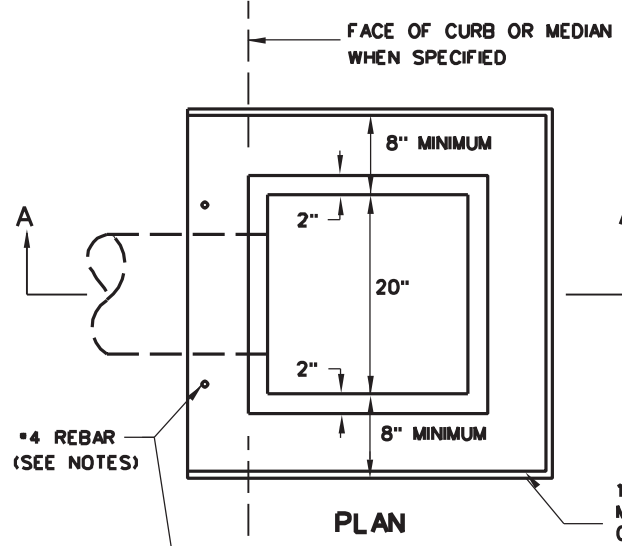

*** OPENING WILL BE 24" FOR 24" DIAMETER OUTLET PIPE

CIRCULAR STYLE 1

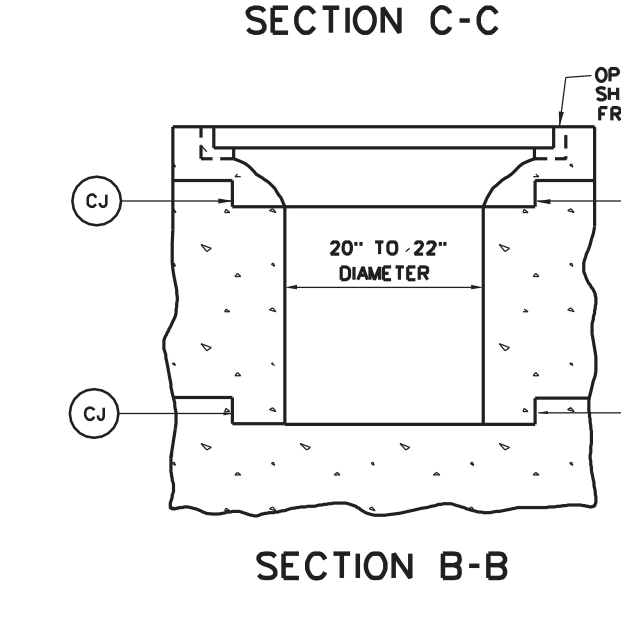
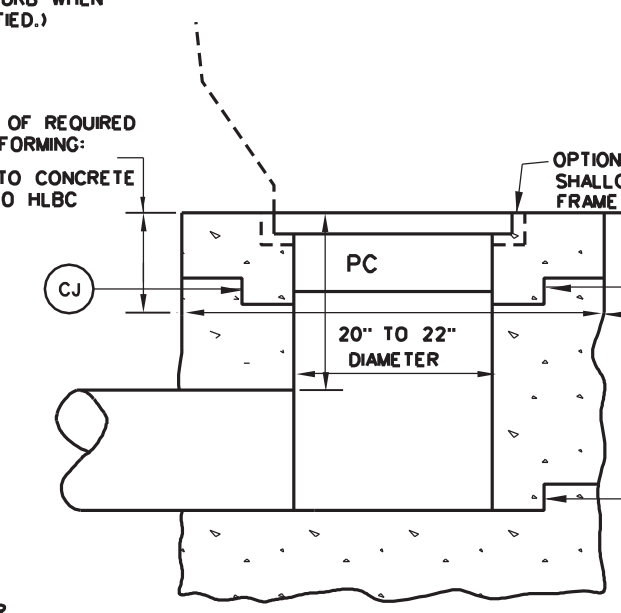
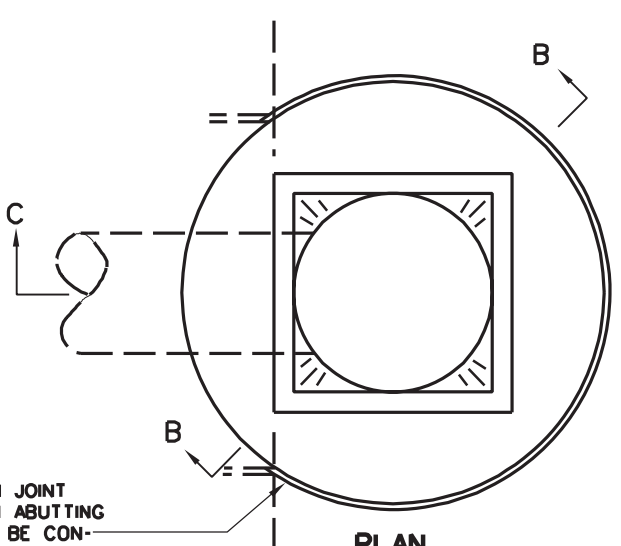

CIRCULAR STYLE 2

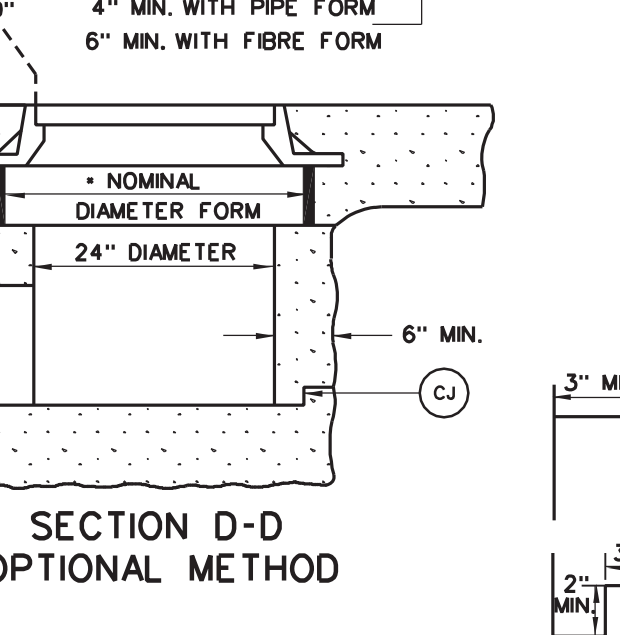
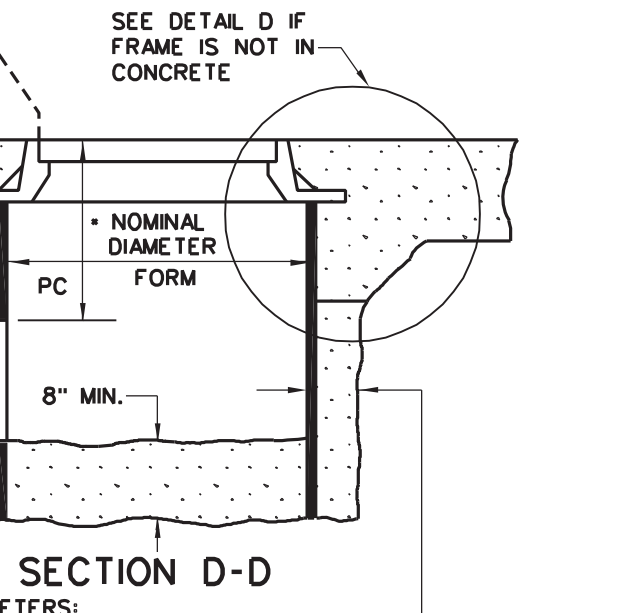
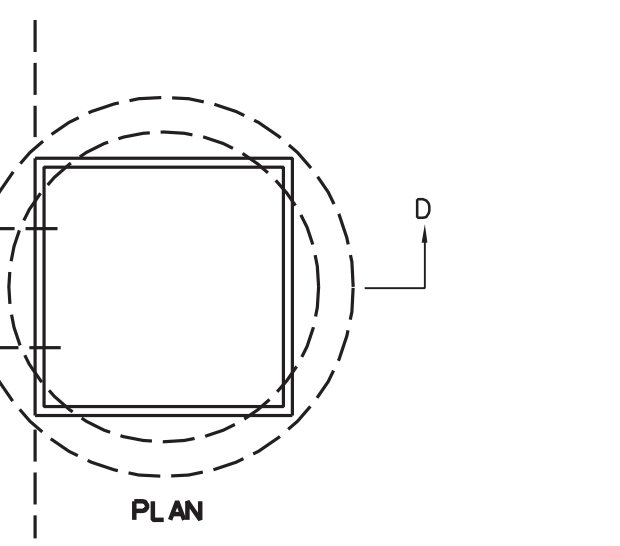

DETAIL D

SEE DETAIL D IF FRAME IS NOT IN CONCRETE

• ROUND FORM NOMINAL DIAMETERS:
CORRUGATED PIPE : 30" 4" MIN. WITH PIPE FORM
FIBRE FORM : 28" 6" MIN. WITH FIBRE FORM

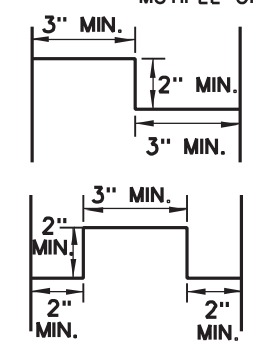

WEST VIRGINIA DEPARTMENT OF TRANSPORTATION
DIVISION OF HIGHWAYS
STANDARD DETAIL

PREPARED 7-1-99
REVISION DATE

TYPE B INLET

NOTES

THE FINAL INSTALLED TOP SURFACE OF INLET AND GRATE SHALL BE FLUSH WITH ADJACENT FINISHED SURFACES SUCH AS PAVEMENT, GUTTERS, CURBS, AND SIDEWALKS. TOP OF GRATE ELEVATION, IF SHOWN ON THE PLANS, IS FOR INFORMATION ONLY.

CONSTRUCTION MAY BE CAST-IN-PLACE, PRECAST IN ONE OR MULTIPLE SECTIONS, OR ANY COMBINATION OF CAST-IN-PLACE AND PRECAST.

REBARS ARE TO BE INSTALLED AT THE QUARTER POINTS TO CONNECT CURB TO INLET. REBARS ARE NOT REQUIRED IF CURB IS POURED MONOLITHICALLY WITH INLET OR IF TYPE V OR VI MEDIAN IS SPECIFIED ON THE PLANS.

FOR DETAILS OF GRATE SUPPORT BAR, SHALLOW FRAME, AND GRATES (TWO REQUIRED), SEE INLET CASTINGS STANDARD SHEET DR6-X.

THE CONTRACTOR MAY, AT HIS OPTION, OMIT USE OF THE FRAME BY FORMING A LEDGE IN THE CONCRETE.

SPECIAL CARE SHALL BE EXERCISED IN FORMING THE 2" WIDE CONCRETE LEDGE TO PROVIDE A SMOOTH, EVEN SURFACE FOR SUPPORTING THE GRATES IF THE SHALLOW FRAME IS NOT USED. NO PROJECTIONS SHALL EXIST ON THE BEARING SURFACES OF THE LEDGE OR THE GRATES AND THE GRATES SHALL SEAT ON THE LEDGE WITHOUT ROCKING.

OPTIONAL CONSTRUCTION JOINTS LABELED "CJ" MAY BE ROUGHENED CONCRETE, KEYPED OR DOWELED AS PER THE TYPICAL DETAILS SHOWN HEREIN OR AS APPROVED BY THE ENGINEER. NON SHRINK GROUT MEETING THE REQUIREMENTS OF SUBSECTION 715.5 OF THE SPECIFICATIONS MAY BE USED TO A DEPTH OF 1/2" FOR LEVELING BETWEEN PRECAST SECTIONS. THICKER DEPTHS WILL BE ALLOWED AS PER THE MANUFACTURER'S RECOMMENDATIONS.

PC (MINIMUM PIPE COVER) SHALL BE 12" BELOW INLET TOP FOR PIPES PLACED UNDER SIDEWALK OR GRASSED AREA OR 24" BELOW INLET TOP FOR PIPES PLACED UNDER PAVEMENT OR SHOULDER.

CURB, IF SPECIFIED, MAY BE EITHER CONCRETE PLACED ON THE INLET BACKWALL AS DETAILED HEREIN OR AN APPROVED CURB BOX AS MANUFACTURED WITH THE GRATE AND FRAME. DIMENSIONS OF THE CURB BOX SHOULD REASONABLY CONFORM TO THE STANDARD CURB AS SPECIFIED ON THE PLANS. THE CURB WILL BE PAID FOR PER SECTION 610, IN EITHER CASE.

THIS INLET SHALL NOT BE PLACED IN A PEDESTRIAN CROSS WALK.

THE MINIMUM DISTANCE FROM THE TOP OF ANY PIPE OPENING TO ANY CONSTRUCTION JOINT ABOVE THE OPENING SHALL BE FOUR (4) INCHES.

THE NUMBER AND LOCATION OF PIPE OPENINGS SHALL BE AS SHOWN IN THE PLANS. THE CONTRACTOR AT NO ADDITIONAL COST, SHALL BE RESPONSIBLE FOR ANY TEMPORARY BRACING REQUIRED TO TRANSPORT PRECAST INLET SECTIONS DUE TO MULTIPLE OPENINGS.

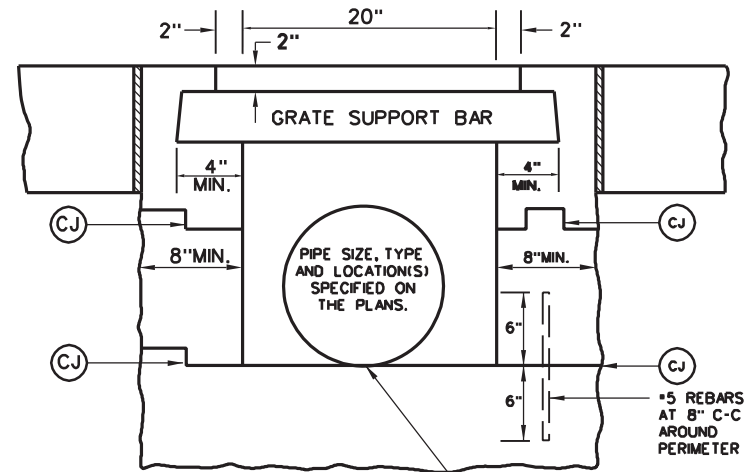
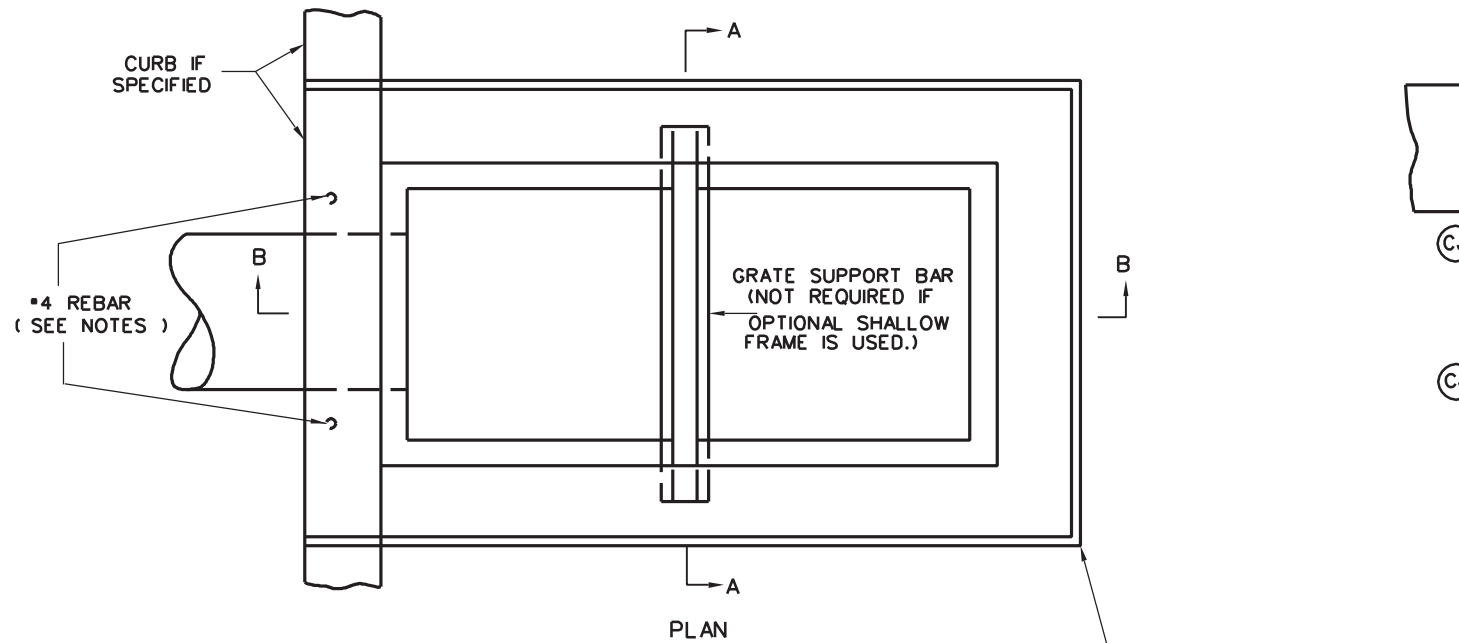

SECTION A-A

FLOWLINE OF OUTLET PIPE SHALL MATCH BOTTOM ELEVATION OF INLET.

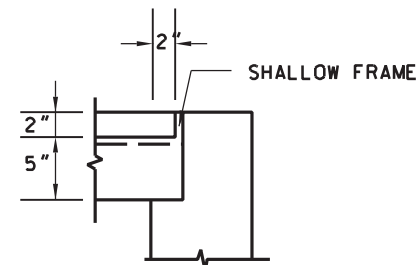

PARTIAL SECTION A-A
(WITH OPTIONAL SHALLOW FRAME)

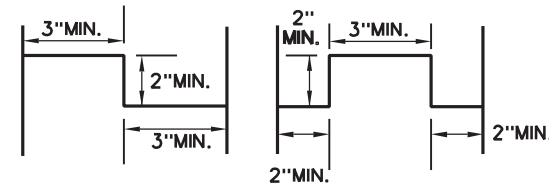

CONSTRUCTION JOINT DETAILS

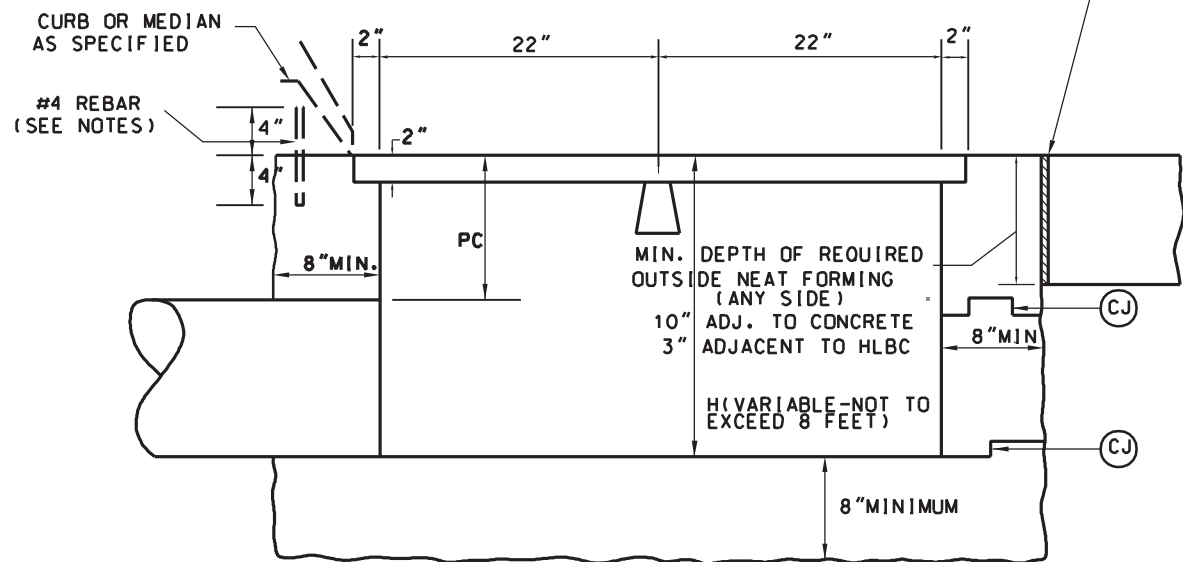

SECTION B-B

1/2" EXPANSION JOINT WHEN ABUTTING CONCRETE

WEST VIRGINIA DEPARTMENT OF TRANSPORTATION
DIVISION OF HIGHWAYS
STANDARD DETAIL

PREPARED 7-1-99
REVISION DATE

TYPE C INLET

STANDARD SHEET DR6-C

NOTES

Optional construction joints labeled "CJ" may be roughened concrete, keyed or doweled as per the typical details shown herein or as approved by the Engineer. Non shrink grout meeting the requirements of subsection 715.5 of the specifications may be used to a depth of 1/2" for leveling between precast sections. Thicker depths will be allowed if as per the manufacturer's recommendations.

The covering for reinforcing steel shall be two inches, measured from the surface of the concrete to the face of the bar, unless otherwise shown. All reinforcing steel shall be epoxy coated and meet the requirements of section 602 of the specifications.

This inlet shall not be placed in a pedestrian cross walk.

Construction may be cast-in-place, precast in one or multiple sections, or any combination of cast-in-place and precast.

The minimum distance from the top of any pipe opening to any construction joint above the opening shall be four (4) inches.

The number and location of pipe openings shall be as shown in the plans. The contractor at no additional cost, shall be responsible for any temporary bracing required to transport precast inlet sections due to multiple openings.

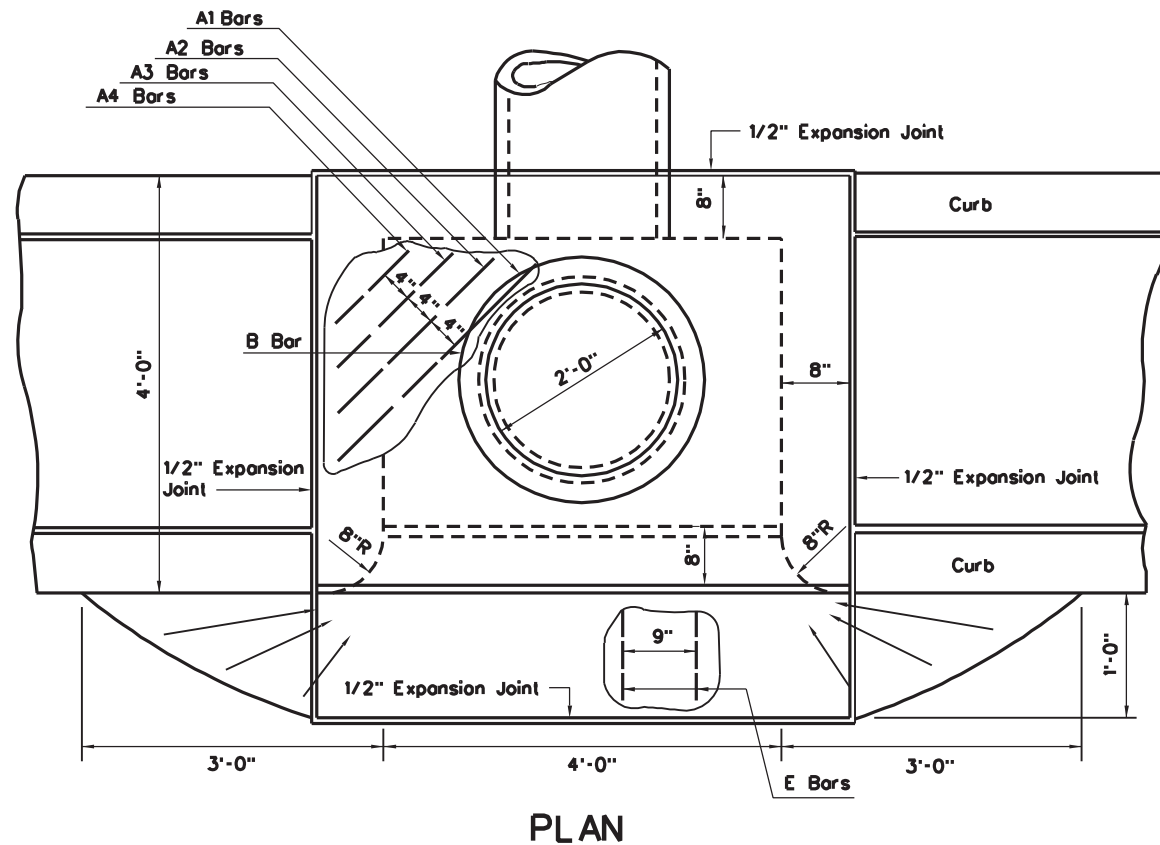

PLAN

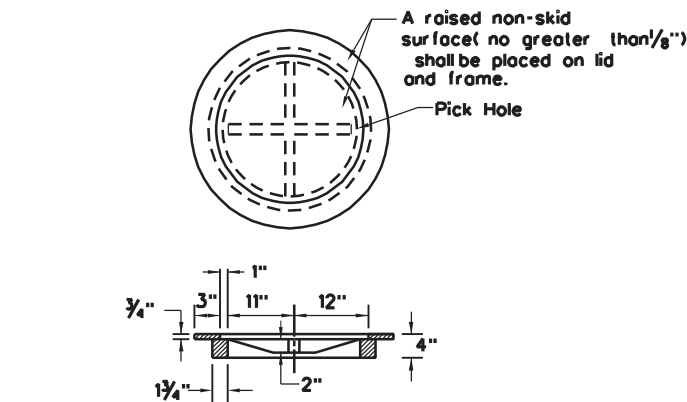

DETAIL OF FRAME AND COVER CASTING (RING TYPE)

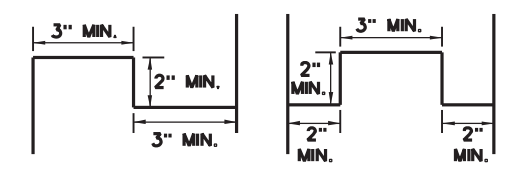

CONSTRUCTION JOINT DETAILS

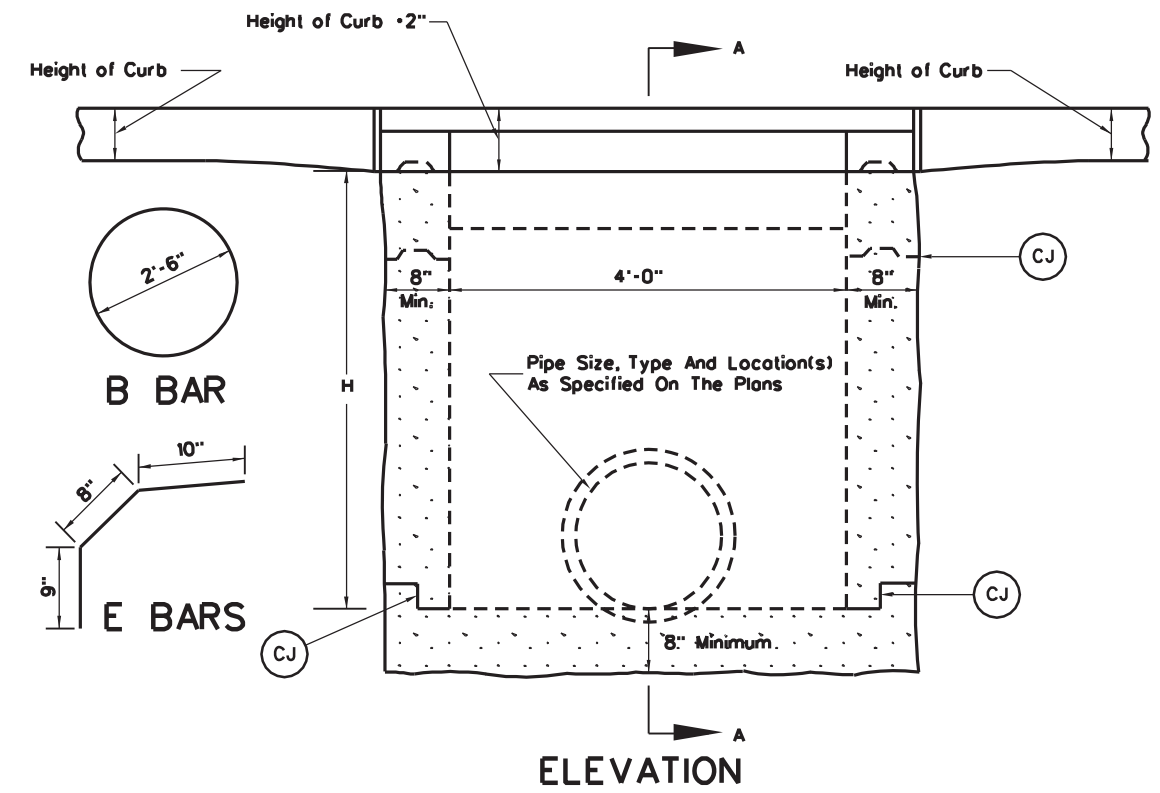

ELEVATION

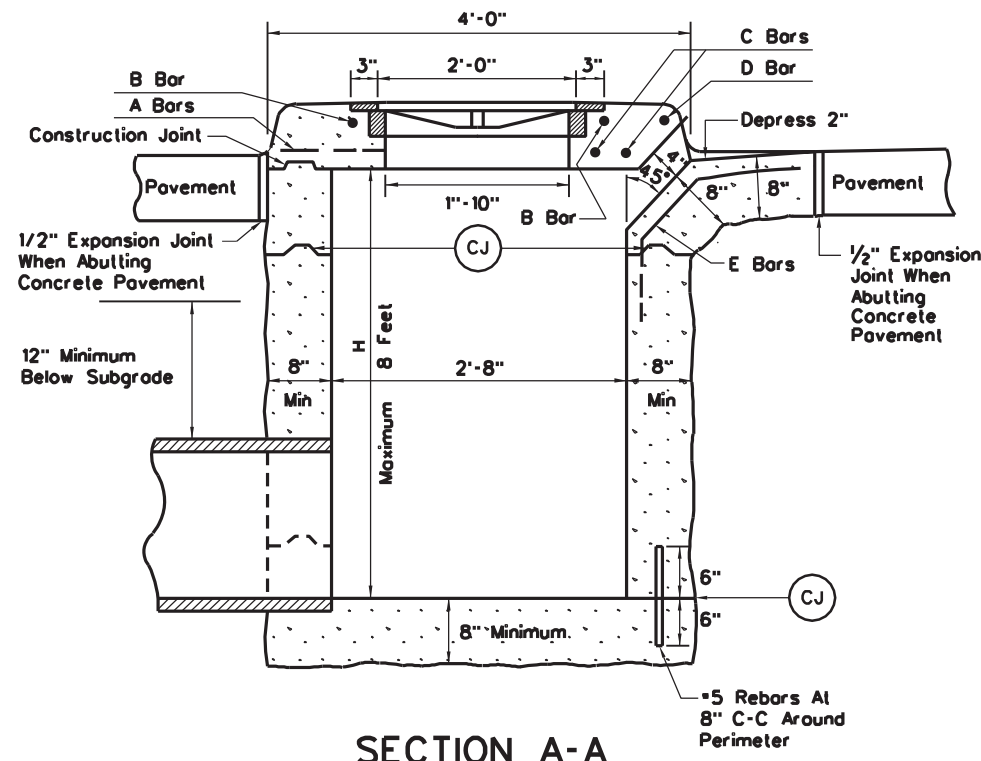

SECTION A-A

BILL OF STEEL				
Mark	Size Bar	No.	Length	Weight
A1	#5	2	3'-11"	8 lbs.
A2	#5	2	3'-3"	7
A3	#5	2	2'-7"	5
A4	#5	2	1'-11"	6
B	#5	1	8'-0"	8
C	#8	2	5'-0"	27
D	#5	1	5'-0"	5
E	#5	6	2'-3"	14
Total				80 lbs.

WEST VIRGINIA DEPARTMENT OF TRANSPORTATION
DIVISION OF HIGHWAYS
STANDARD DETAIL

PREPARED 7-1-99

REVISION DATE

TYPE D INLET

STANDARD SHEET DR6-D

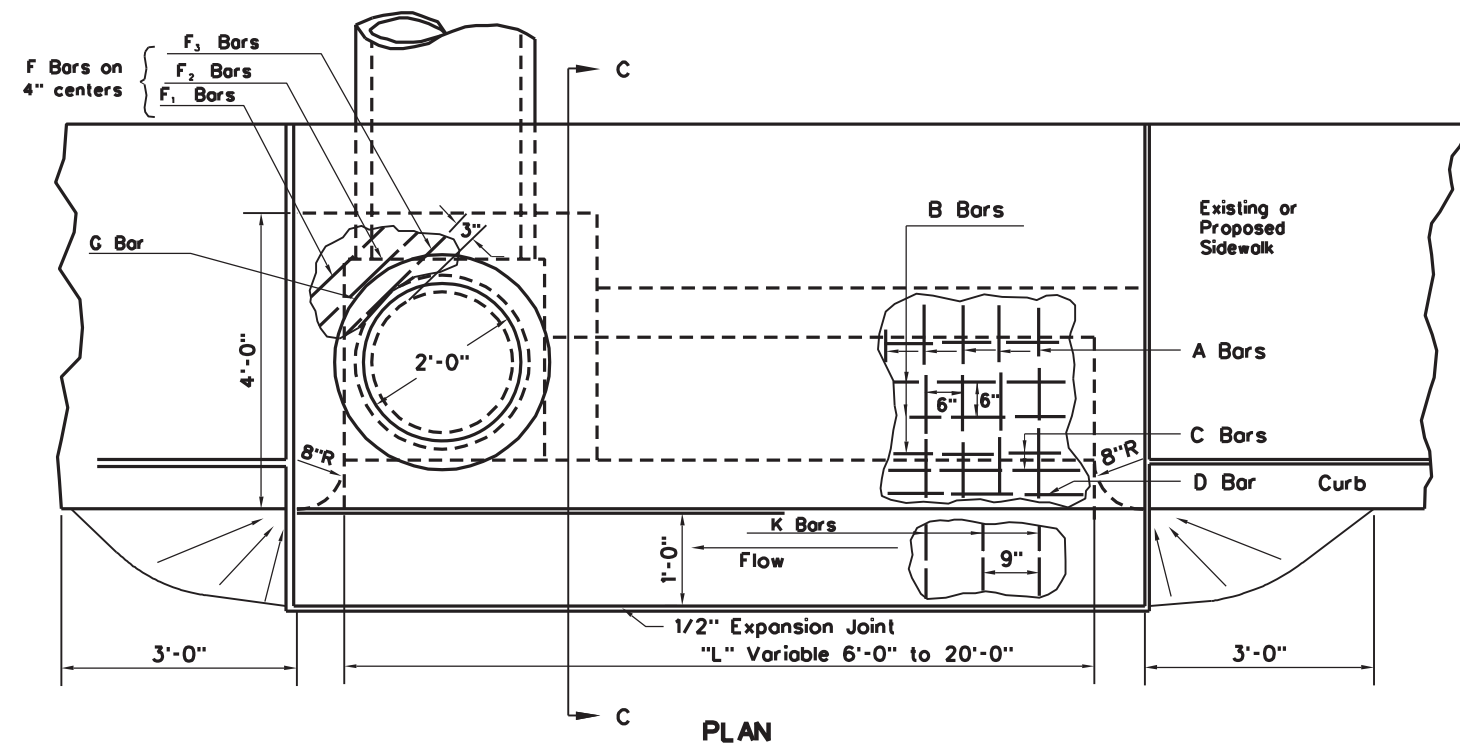

PLAN

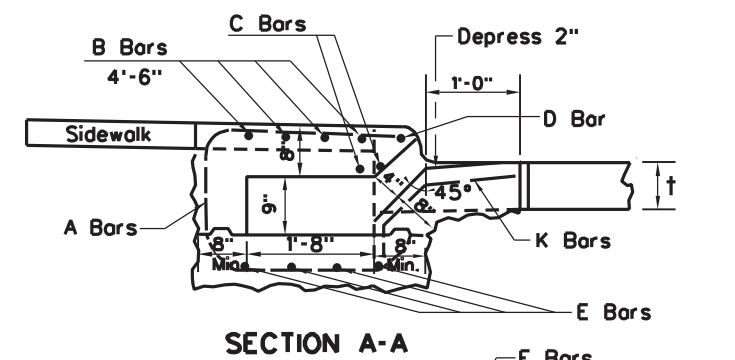

SECTION A-A

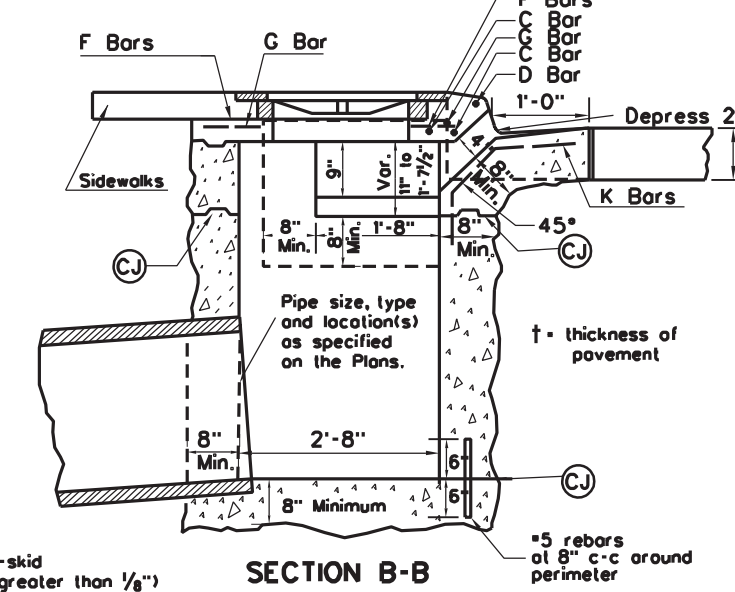

SECTION B-B

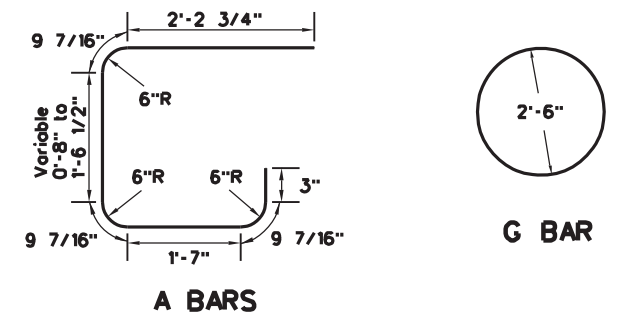

A BARS

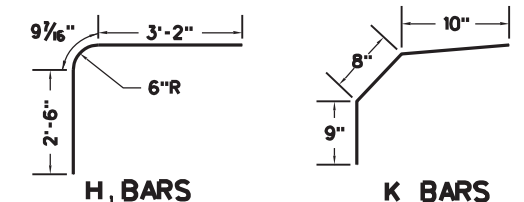

H BARS

K BARS

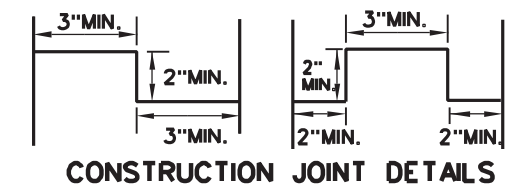

CONSTRUCTION JOINT DETAILS

NOTES

Type E Inlet detailed herein is for use on a grade. If it is to be used in a sag (see sketch herein) it should be built symmetrically about centerline of pipe and length of opening specified.

The covering for reinforcing steel shall be two inches, measured from the surface of the concrete to the face of the bar, unless otherwise shown. All reinforcing steel shall be epoxy-coated and meet the requirements of Section 602 of the Specifications.

Optional construction joints labeled "CJ" may be keyed or doweled as per the typical details shown herein or as approved by the Engineer.

If Type E Inlet is to be constructed along with a sidewalk, the sidewalk shall be constructed monolithic with the top slab on the inlet. The sidewalk shall be reinforced with Type B Fabric placed 2" from bottom of sidewalk and extended into the top slab of the inlet a minimum distance of 8". Cost of Type B Fabric shall be included in the unit price bid for Concrete Sidewalk.

This inlet shall not be placed in a pedestrian cross walk.

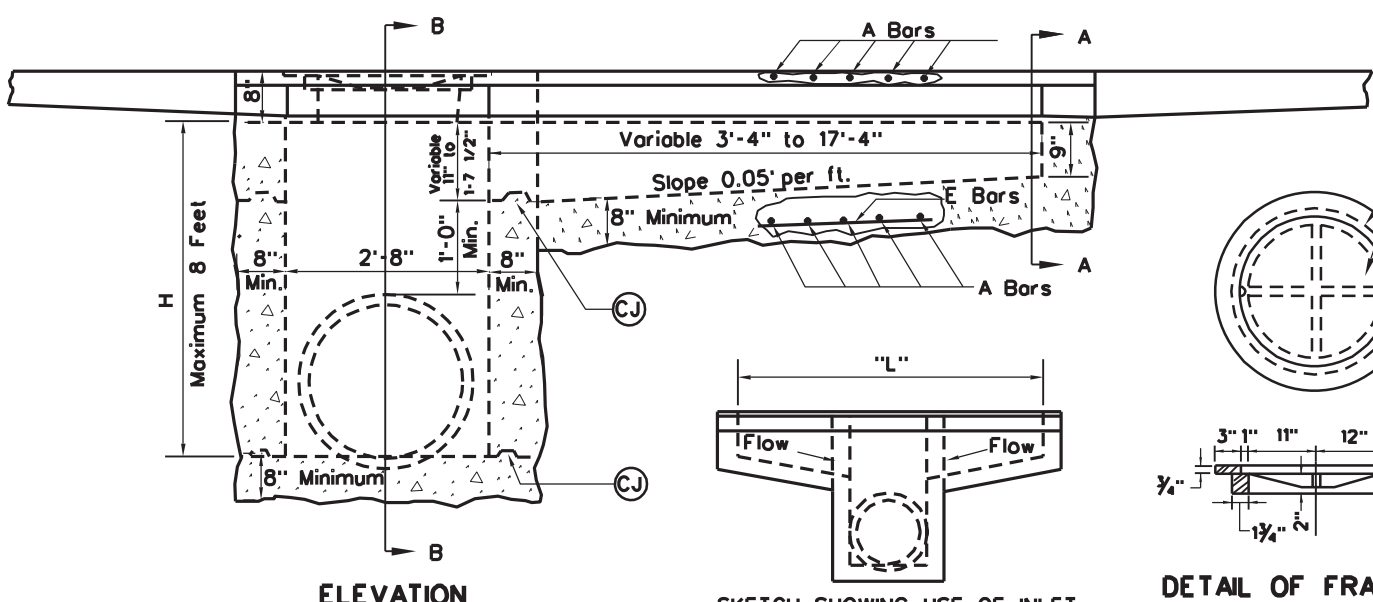

ELEVATION



SKETCH SHOWING USE OF INLET IN SAGS. BOTH SIDES TO BE SYMMETRICAL.

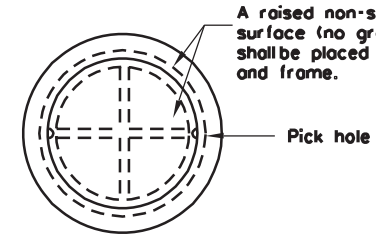

DETAIL OF FRAME AND COVER CASTING

CONCRETE AND REINFORCING STEEL QUANTITIES

"L" Feet	Concrete C.Y.*	Reinforcing Steel lbs.	A Bars (Bent)			B Bars (Straight)			C Bars (Straight)			D Bars (Straight)			E Bars (Straight)			F ₁ Bars (Straight)			F ₂ Bars (Straight)			F ₃ Bars (Straight)			G Bar (Bent)			H ₁ Bars (Straight)			H ₂ Bars (Straight)			K Bars (Bent)		
			No.	Size	Length	No.	Size	Length	No.	Size	Length	No.	Size	Length	No.	Size	Length	No.	Size	Length	No.	Size	Length	No.	Size	Length	No.	Size	Length	No.	Size	Length	No.	Size	Length	No.	Size	Length
6	2.59	189	5	#5	7'-1" to 7'-3"	4	#5	3'-9"	2	#5	7'-1"	1	#5	7'-1"	4	#5	3'-6"	4	#5	2'-0"	4	#5	2'-6"	4	#5	3'-0"	1	#5	8'-0"	2	#7	6'-5"	2	#6	3'-4"	10	#5	2'-3"
8	3.07	250	9	#5	7'-1" to 7'-4"	4	#5	5'-9"	2	#5	9'-1"	1	#5	9'-1"	4	#5	5'-6"	4	#5	2'-0"	4	#5	2'-6"	4	#5	3'-0"	1	#5	8'-0"	2	#7	6'-5"	2	#6	3'-4"	13	#5	2'-3"
10	3.57	308	13	#5	7'-1" to 7'-5"	4	#5	7'-9"	2	#5	11'-1"	1	#5	11'-1"	4	#5	7'-6"	4	#5	2'-0"	4	#5	2'-6"	4	#5	3'-0"	1	#5	8'-0"	2	#7	6'-5"	2	#6	3'-4"	15	#5	2'-3"
12	4.09	369	17	#5	7'-1" to 7'-6"	4	#5	9'-9"	2	#5	13'-1"	1	#5	13'-1"	4	#5	9'-6"	4	#5	2'-0"	4	#5	2'-6"	4	#5	3'-0"	1	#5	8'-0"	2	#7	6'-5"	2	#6	3'-4"	18	#5	2'-3"
14	4.62	444	21	#5	7'-1" to 7'-7"	4	#5	11'-9"	2	#6	15'-1"	1	#5	15'-1"	4	#5	11'-6"	4	#5	2'-0"	4	#5	2'-6"	4	#5	3'-0"	1	#5	8'-0"	2	#7	6'-5"	2	#6	3'-4"	21	#5	2'-3"
16	5.17	506	25	#5	7'-1" to 7'-9"	4	#5	13'-9"	2	#6	17'-1"	1	#5	17'-1"	4	#5	13'-6"	4	#5	2'-0"	4	#5	2'-6"	4	#5	3'-0"	1	#5	8'-0"	2	#7	6'-5"	2	#6	3'-4"	23	#5	2'-3"
18	5.74	570	29	#5	7'-1" to 7'-10"	4	#5	15'-9"	2	#6	19'-1"	1	#5	19'-1"	4	#5	15'-6"	4	#5	2'-0"	4	#5	2'-6"	4	#5	3'-0"	1	#5	8'-0"	2	#7	6'-5"	2	#6	3'-4"	26	#5	2'-3"
20	6.19	636	33	#5	7'-1" to 8'-0"	4	#5	17'-9"	2	#6	21'-1"	1	#5	21'-1"	4	#5	17'-6"	4	#5	2'-0"	4	#5	2'-6"	4	#5	3'-0"	1	#5	8'-0"	2	#7	6'-5"	2	#6	3'-4"	29	#5	2'-3"

* The quantities shown above are for an H of five feet. If deeper inlets are required the quantities must be adjusted accordingly.

The above table to be used for estimating purposes only.

WEST VIRGINIA DEPARTMENT OF TRANSPORTATION
DIVISION OF HIGHWAYS
STANDARD DETAIL

PREPARED 7-1-99
REVISION DATE

TYPE E INLET

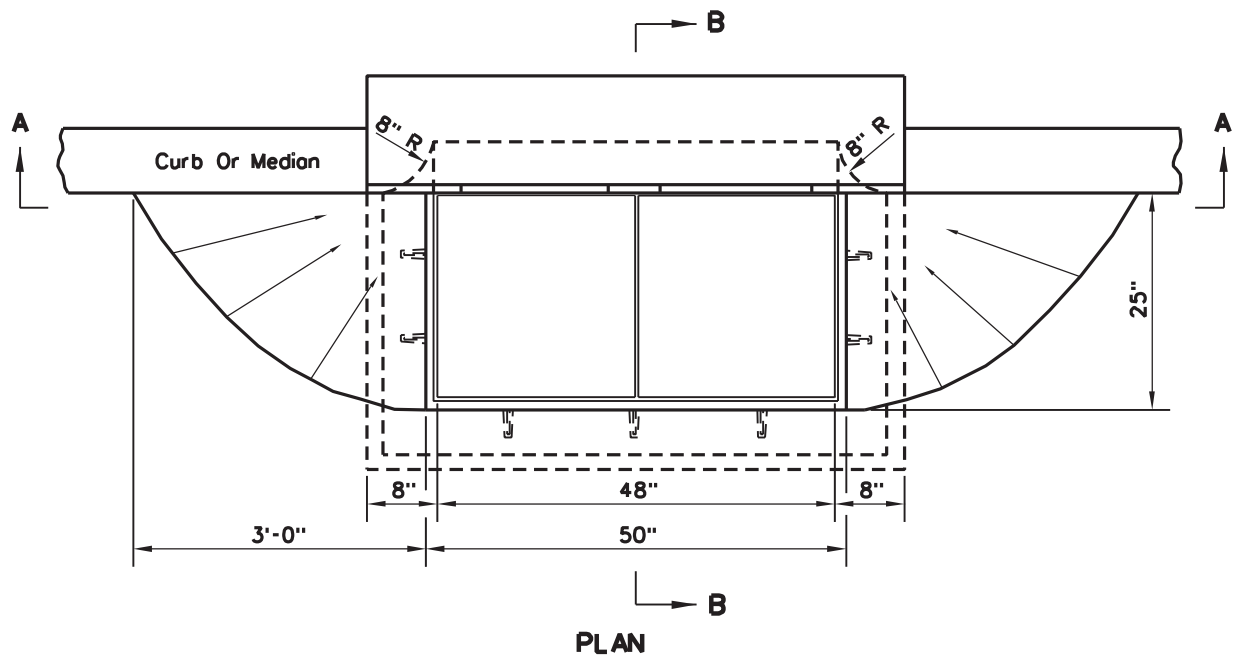

C - Curb Height

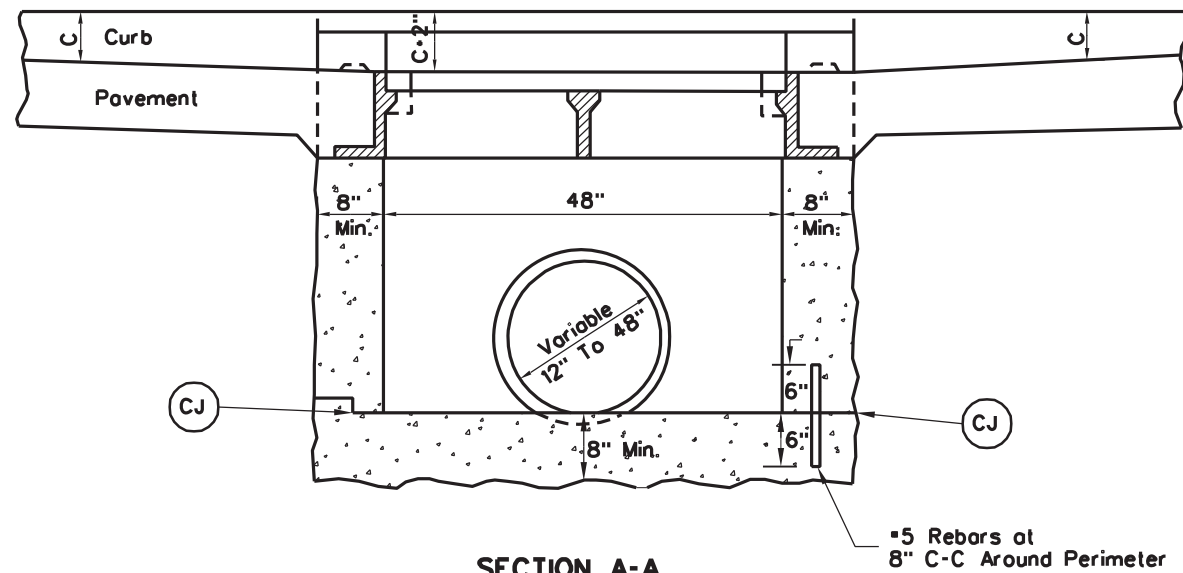

SECTION A-A
(Grates Not Shown)

*5 Rebars at 8" C-C Around Perimeter

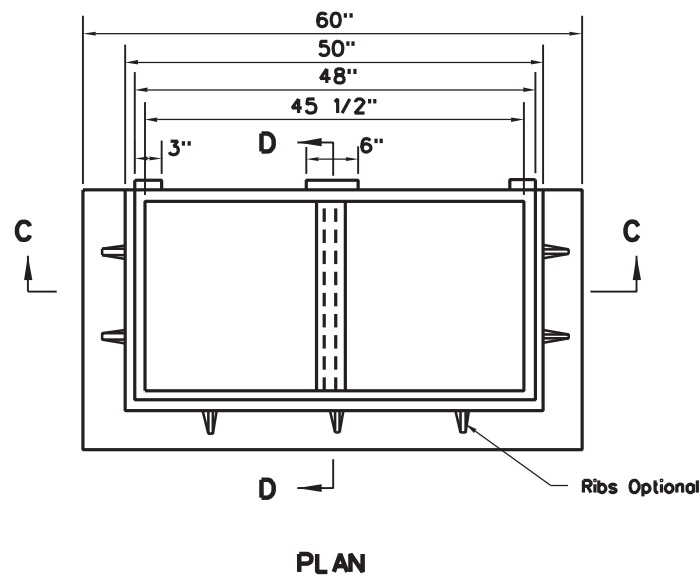

PLAN

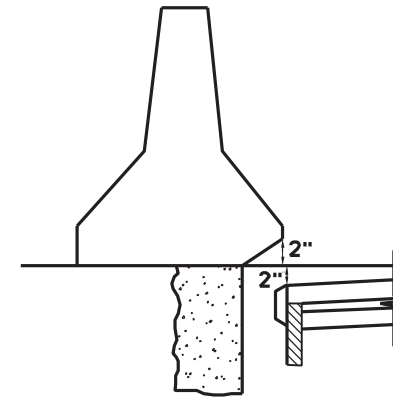

DETAIL A

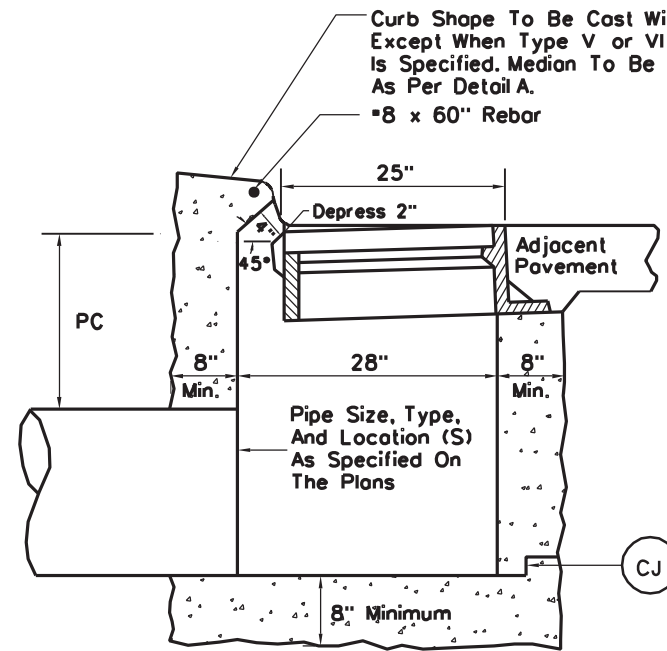

SECTION B-B
(Grates Not Shown)

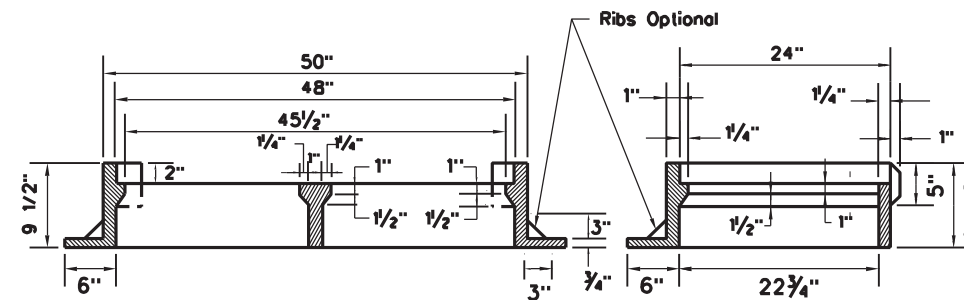

SECTION C-C

SECTION D-D

DETAIL OF FRAME

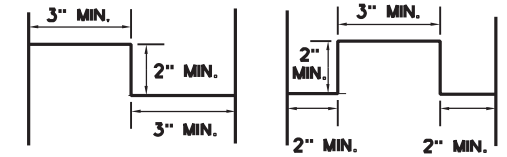

CONSTRUCTION JOINT DETAILS

NOTES

The final installed top surface of inlet and grate shall be flush with adjacent finished surfaces such as pavement, gutters, curbs, and sidewalks. Top of grate elevation, if shown on the plans, is for information only.

Construction may be cast-in-place, precast in one or multiple sections, or any combination of cast-in-place and precast.

Optional construction joints labeled "CJ" may be roughened concrete, keyed or doweled as per the typical details shown herein or as approved by the Engineer. Non shrink grout meeting the requirements of subsection 715.5 of the specifications may be used to a depth of 1/2" for leveling between precast sections. Thicker depths will be allowed if as per the manufacturer's recommendations.

The covering for reinforcing steel shall be two inches, measured from the surface of the concrete to the face of the bar, unless otherwise shown.

For details of grates (two required), see Inlet Castings Standard Sheet DR6-X.

PC (minimum pipe cover) shall be 12" below inlet top for pipes placed under sidewalk or grassed area or 24" below inlet top for pipes placed under pavement or shoulder.

Curb, if specified, may be either concrete placed on the inlet backwall as detailed herein or an approved curb box as manufactured with the grate and frame. Dimensions of the curb box should reasonably conform to the standard curb as specified on the plans. The curb will be paid for per section 610, in either case.

This inlet shall not be placed in a pedestrian cross walk.

The minimum distance from the top of any pipe opening to any construction joint above the opening shall be four (4) inches.

The number and location of pipe openings shall be as shown in the plans. The contractor at no additional cost, shall be responsible for any temporary bracing required to transport precast inlet sections due to multiple openings.

WEST VIRGINIA DEPARTMENT OF TRANSPORTATION
DIVISION OF HIGHWAYS
STANDARD DETAIL

PREPARED 7-1-99

REVISION DATE

TYPE F INLET

STANDARD SHEET DR6-F

INLET MOUNDING TABLE			
DITCH GRADE (Z)		L1, HORIZONTAL LENGTH (FT.)	L2, HORIZONTAL LENGTH (FT.)
FROM	TO		
0	3	10	15
3	5	9	20
5	7.5	8	40
7.5	UP	SPECIAL DESIGN	SPECIAL DESIGN

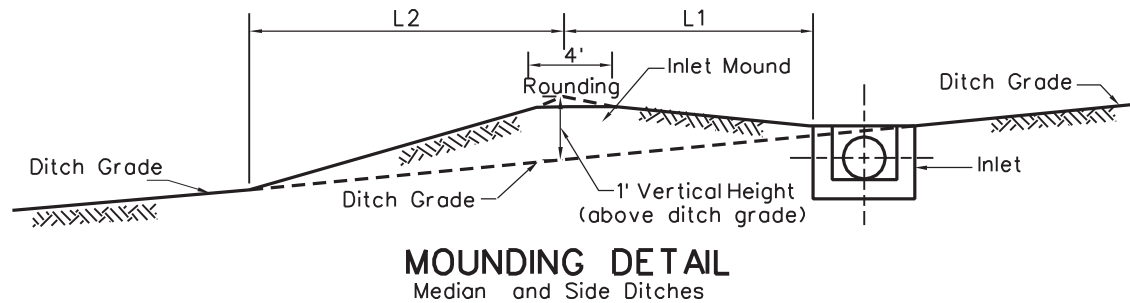

NOTES

The final installed top surface of inlet and grate shall be flush with adjacent finished surfaces such as pavement, gutters, curbs, and sidewalks. Top of grate elevation, if shown on the plans, is for information only.

Construction may be cast-in place, precast in one or multiple sections, or any combination of cast-in-place and precast.

Type 2 Grate shall be used at all locations unless otherwise specified on the Plans. Type 1 Urban Grates shall be used only at specially designated locations as shown on the plans.

The Contractor, at his option, may omit use of the frame by forming a ledge in the concrete.

Special care shall be exercised in forming the 2" wide concrete ledge to provide a smooth, even surface for supporting the grates if the shallow frame is not used. No projections shall exist on the bearing surfaces of the ledge or the grates, and the grates shall seat on the ledge without rocking.

The Mounding Detail as shown is not required when an inlet is placed in a sag.

Optional construction joints labeled "CJ" may be roughened concrete, keyed or doweled as per the typical details shown herein or as approved by the Engineer. Non shrink grout meeting the requirements of subsection 715.5 of the specifications may be used to a depth of 1/2" for leveling between precast sections. Thicker depths will be allowed as per the manufacturer's recommendations.

This inlet is to be installed in roadside or median ditches only. It is not to be placed adjacent to pavement or in the gutter pan of combination curb and gutter.

The minimum distance from the top of any pipe opening to any construction joint above the opening shall be four (4) inches.

The number and location of pipe openings shall be as shown in the plans. The contractor at no additional cost, shall be responsible for any temporary bracing required to transport precast inlet sections due to multiple openings.

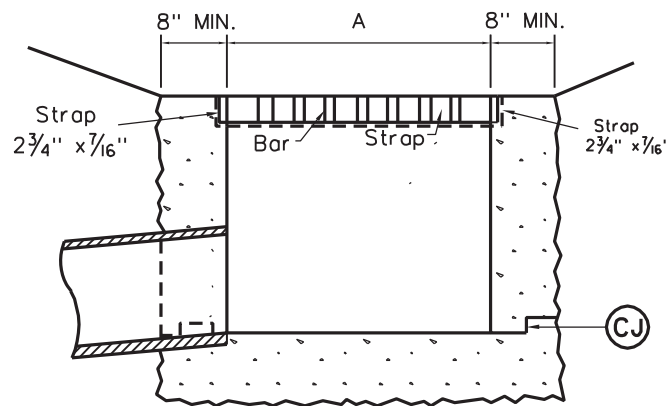

SECTION A-A
(Type 2 Grate Shown)

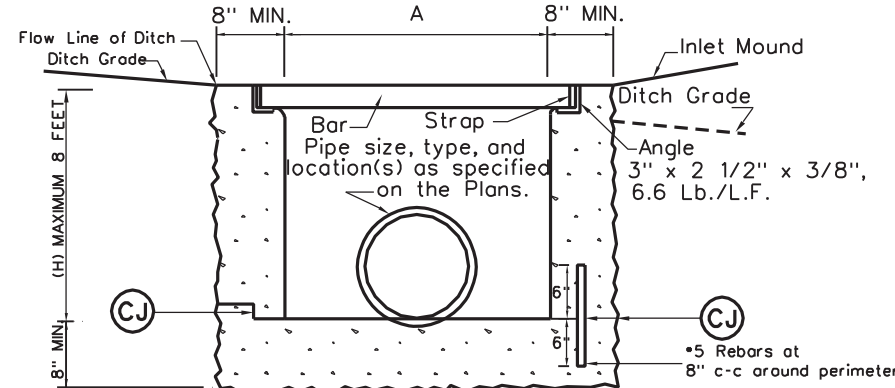

SECTION B-B

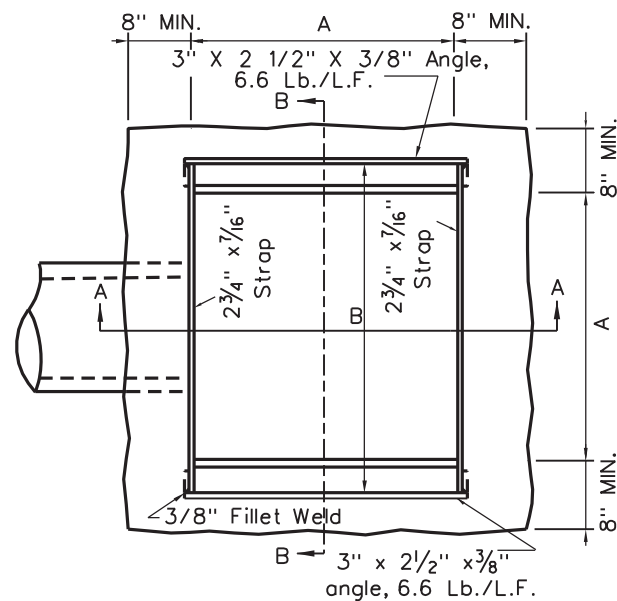

PLAN

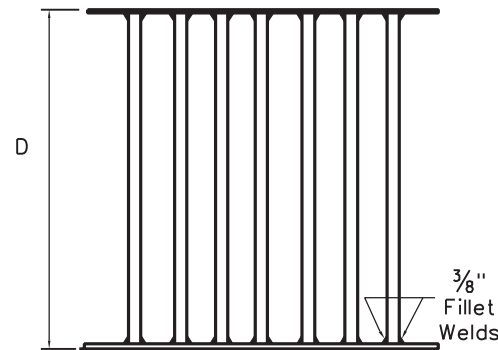

PLAN VIEW-TYPE 2 GRATE

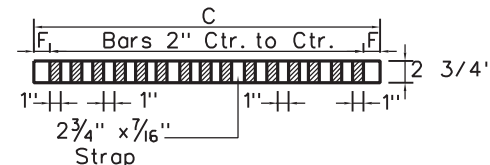

SECTION THROUGH TYPE 1 GRATE

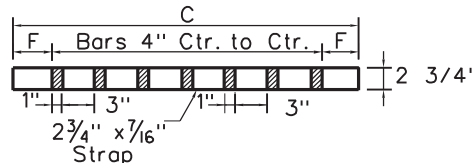

SECTION THROUGH TYPE 2 GRATE

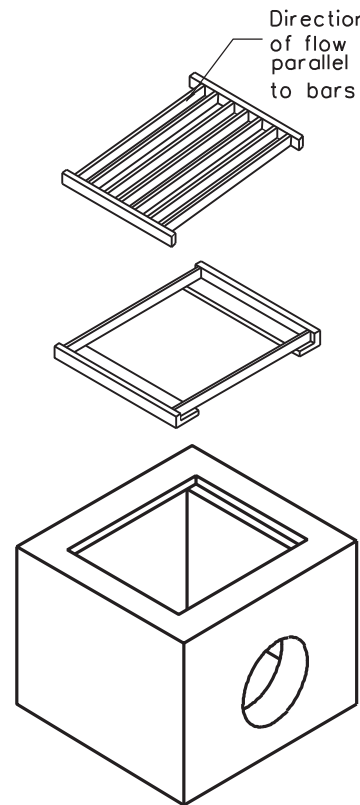

EXPLODED DETAIL

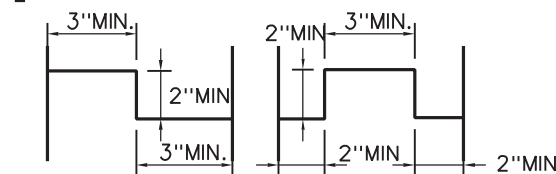

CONSTRUCTION JOINT DETAILS

Pipe Size	DIMENSIONS				TYPE 2 GRATE			FRAME			TYPE 1 GRATE		
	A	B	C	D	H(Min)	F	Bars	WT.	WT.	F	Bars	WT.	
18"	2'-8"	3'-2"	2'-7 3/4"	3'-1 3/4"	2'-0"	3 3/8"	7	223	62	1 3/8"	15	453	
21"	2'-8"	3'-2"	2'-7 3/4"	3'-1 3/4"	2'-3"	3 3/8"	7	223	62	1 3/8"	15	453	
24"	2'-8"	3'-2"	2'-7 3/4"	3'-1 3/4"	2'-6"	3 3/8"	7	223	62	1 3/8"	15	453	
27"	3'-0"	3'-6"	2'-11 3/4"	3'-5 3/4"	2'-9"	3 3/8"	8	279	69	1 3/8"	17	566	
30"	3'-6"	4'-0"	3'-5 3/4"	3'-11 3/4"	3'-0"	3 3/8"	9	357	80	1 3/8"	21	797	
33"	3'-9"	4'-3"	3'-8 3/4"	4'-2 3/4"	3'-3"	3 7/8"	10	419	85	1 7/8"	21	847	
36"	4'-0"	4'-6"	3'-11 3/4"	4'-5 3/4"	3'-6"	3 3/8"	11	486	90	1 3/8"	23	981	
42"	4'-6"	5'-0"	4'-5 3/4"	4'-11 3/4"	4'-0"	3 3/8"	12	587	101	1 3/8"	27	1277	
48"	5'-0"	5'-6"	4'-11 3/4"	5'-5 3/4"	4'-6"	3 3/8"	14	748	112	1 3/8"	29	1507	

Table Note: Grate and frame weights are for information only and will increase if larger straps and bars are used.

The following substitutions in dimensions are acceptable for fabricating the grate and frame:

Strap Thickness: 1/2"

Strap Depth: 3"

Bar Depth: 3"

WEST VIRGINIA DEPARTMENT OF TRANSPORTATION
DIVISION OF HIGHWAYS
STANDARD DETAIL

PREPARED 7-1-99
REVISION DATE

TYPE G INLET

STANDARD SHEET DR6-G

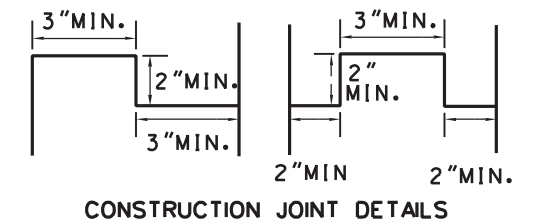
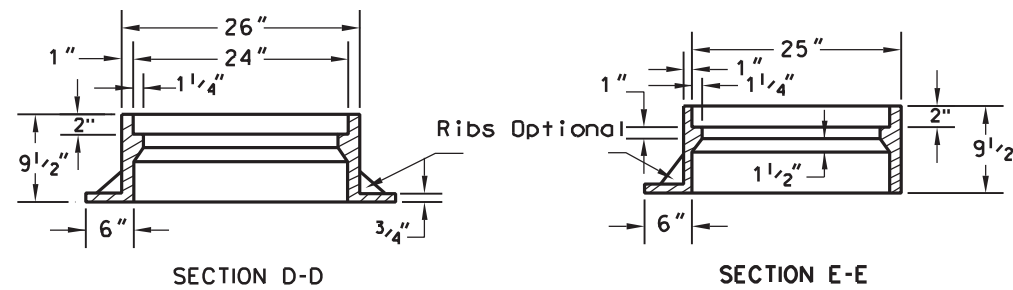
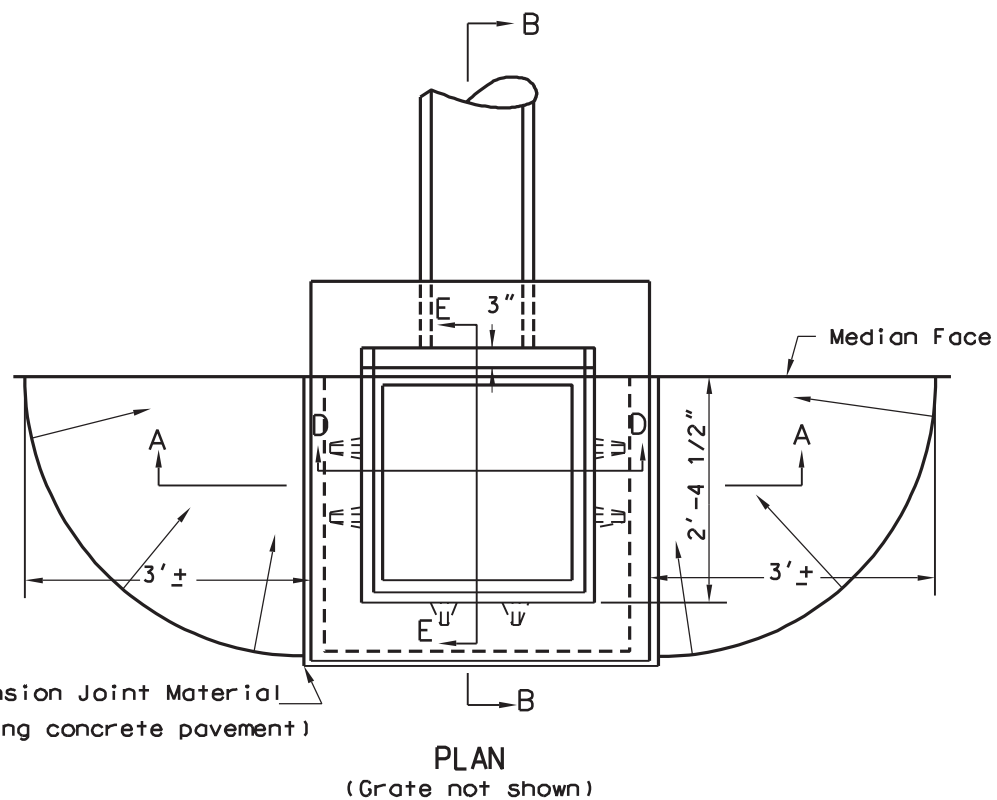

NOTES

The final installed top surface of inlet and grate shall be flush with adjacent finished surfaces such as pavement, gutters, curbs, and sidewalks. Top of grate elevation, if shown on the plans, is for information only.

Construction may be cast-in-place, precast in one or multiple sections, or any combination of cast-in-place and precast.

This inlet is intended for use with type V and VI medians (concrete barrier medians) as specified on the plans.

Optional construction joints labeled "CJ" may be roughened concrete, keyed or doweled as per the typical details shown herein or as approved by the Engineer. Non shrink grout meeting the requirements of subsection 715.5 of the specifications may be used to a depth of 1/2" for leveling between precast sections. Thicker depths will be allowed as per the manufacturer's recommendations.

Grate as shown on Standard Sheet DR6-X to be used with this inlet.

PC (minimum pipe cover) shall be 12" below inlet top for pipes placed under sidewalk or grassed area or 24" below inlet top for pipes placed under pavement or shoulder.

This inlet shall not be placed in a pedestrian cross walk.

The minimum distance from the top of any pipe opening to any construction joint above the opening shall be four (4) inches.

The number and location of pipe openings shall be as shown in the plans. The contractor at no additional cost, shall be responsible for any temporary bracing required to transport precast inlet sections due to multiple openings.

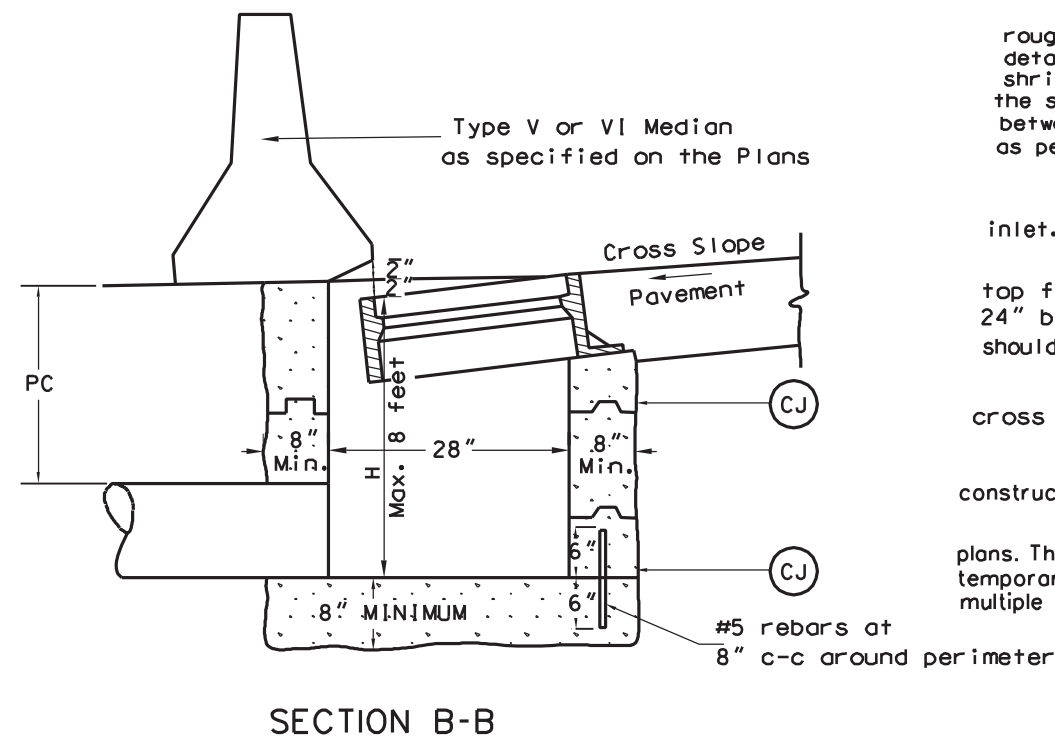
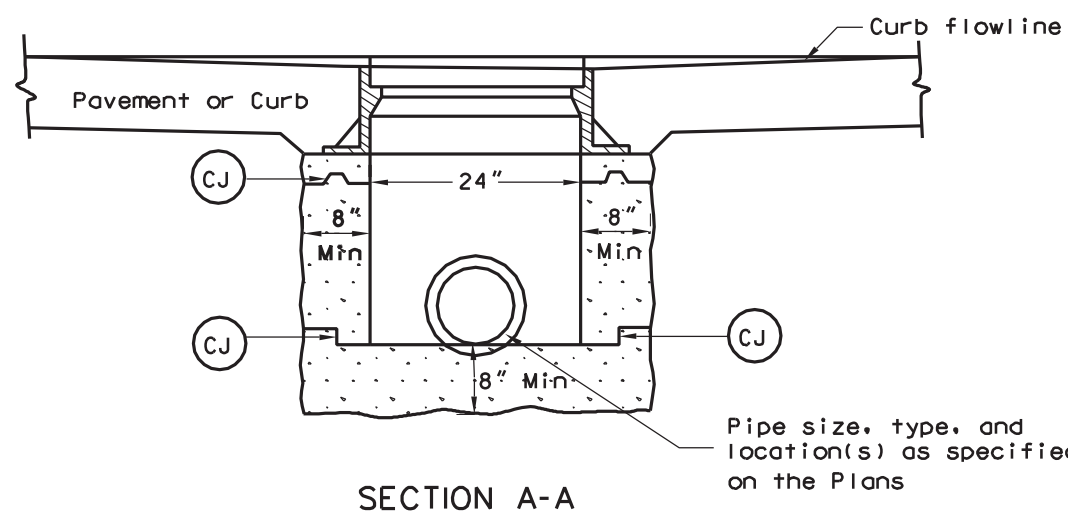

WEST VIRGINIA DEPARTMENT OF TRANSPORTATION
DIVISION OF HIGHWAYS
STANDARD DETAIL

PREPARED 7-1-99
REVISION DATE

TYPE H INLET

TYPICAL INSTALLATIONS

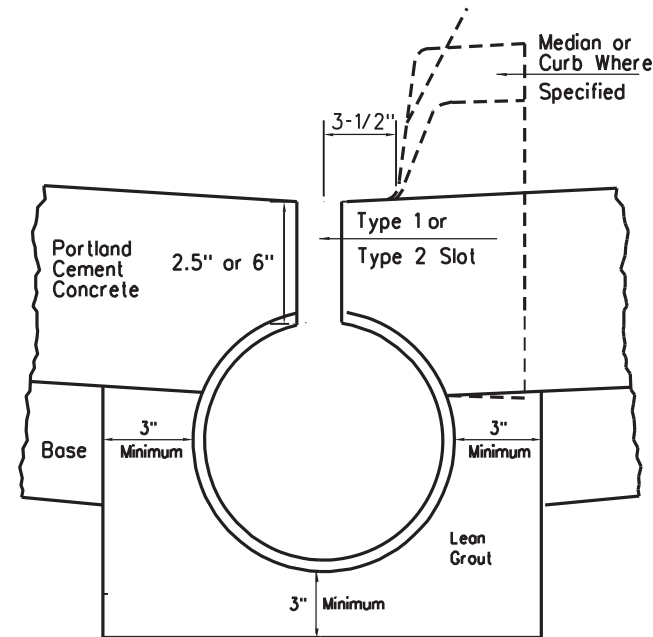
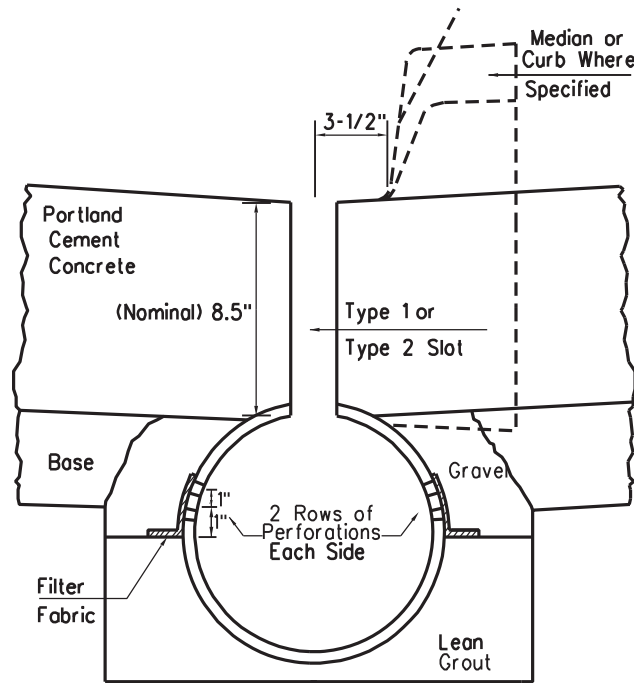
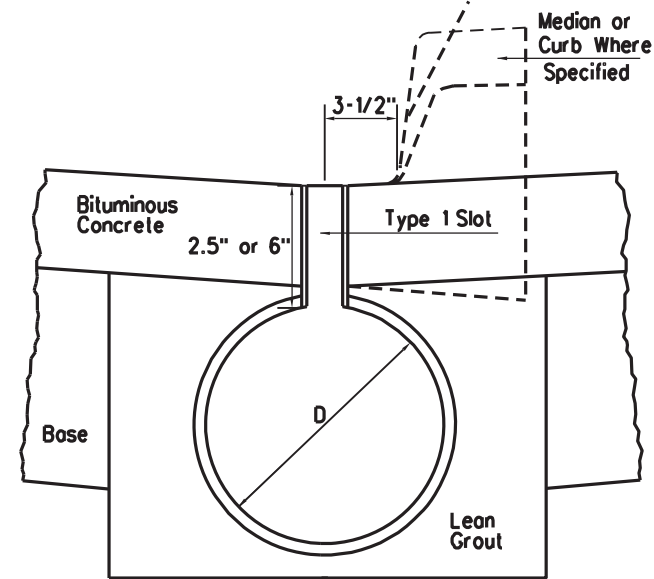
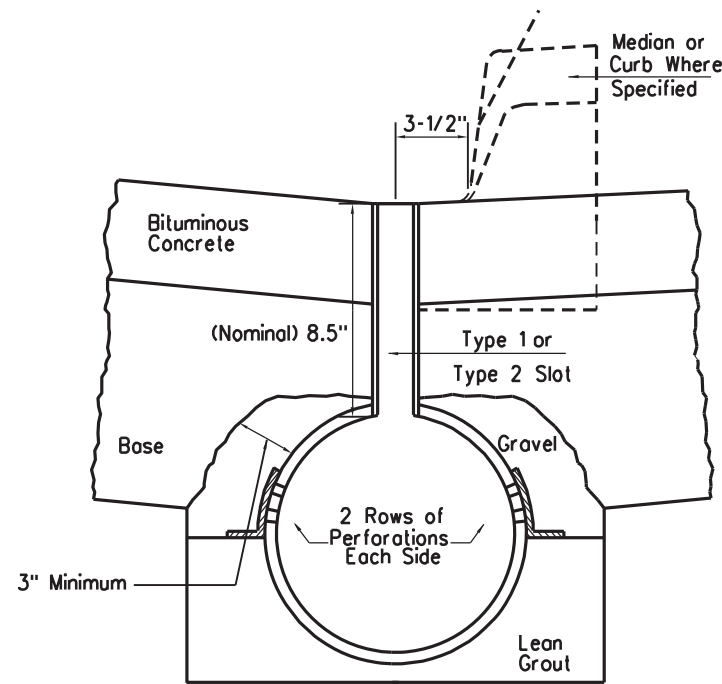

SLOT DETAILS

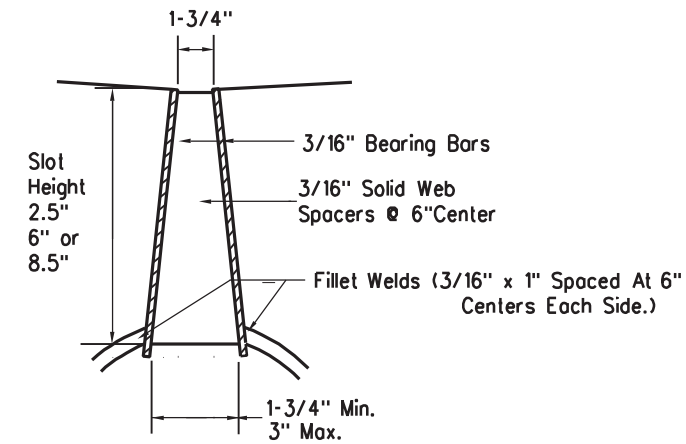

TYPE 1 SLOT

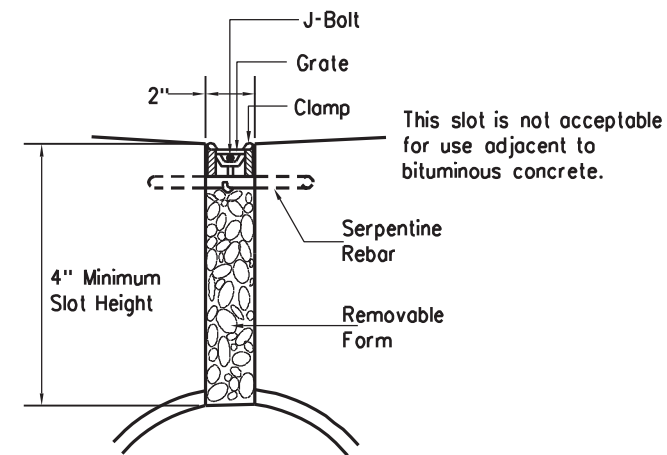

TYPE 2 SLOT

NOTES

The contractor may, at his option but subject to the limitations as noted on this sheet and elsewhere on the plans, install Type 1 or 2 Slots or approved equals.

When specified on the plans, Type 1 slots shall include expanded steel mesh heelguards tack welded to the spacer bars.

Gravel shall be omitted from the perforated slot inlet installation when free-draining base is specified and will be placed against the inlet.

When slot heights of 8.5" are specified, the Type 1 slots may be fabricated by stacking a 2.5" slot on top of a 6" slot. The assembly shall then be joined by minimum 3/16" x 1" fillet welds at 6" centers along each side of the horizontal joint. The resultant slot height may be slightly less than 8 1/2".

Slot inlet shall not be placed across a pedestrian cross walk.

SLOTS NOTES

TYPE 1 SLOT

BEARING BARS AND SPACERS: These elements are to be 3/16" structural steel suitably welded to form the open slot and hot-dip galvanized as per ASTM A-123. Spacer may be vertical or tilted at approximately 30° from vertical. If the slot inlet is placed on a grade and adjacent to a curb or median, the inlet is to be installed to position tilted spacers to tilt upgrade toward the incoming gutter flow.

TYPE 2 SLOT

GRATE AND CLAMP: These parts are to be hot-dip galvanized mild carbon steel conforming to ASTM A569. Grating, measuring 3/4" deep by 1-3/4" wide, shall extend the full length of each pipe section slot.

REBARS: The rebar shall be serpentine bent to cross the slotted opening on 6" centers and shall be coated with 7 mils of fusion-bonded epoxy powder.

J-BOLT: The J-bolt shall be 5/16 inch diameter, plated, ASTM A307 steel supplied with self-locking nuts.

REMOVABLE FORMS: Forms are to be cellular foam with a wood or plastic cap.

SLOT HEIGHT: 4" minimum slot height acceptable where 2.5" slot height is specified.

WEST VIRGINIA DEPARTMENT OF TRANSPORTATION
DIVISION OF HIGHWAYS
STANDARD DETAIL

PREPARED 7-1-99

REVISION DATE

SLOT INLET

STANDARD SHEET DR6-S

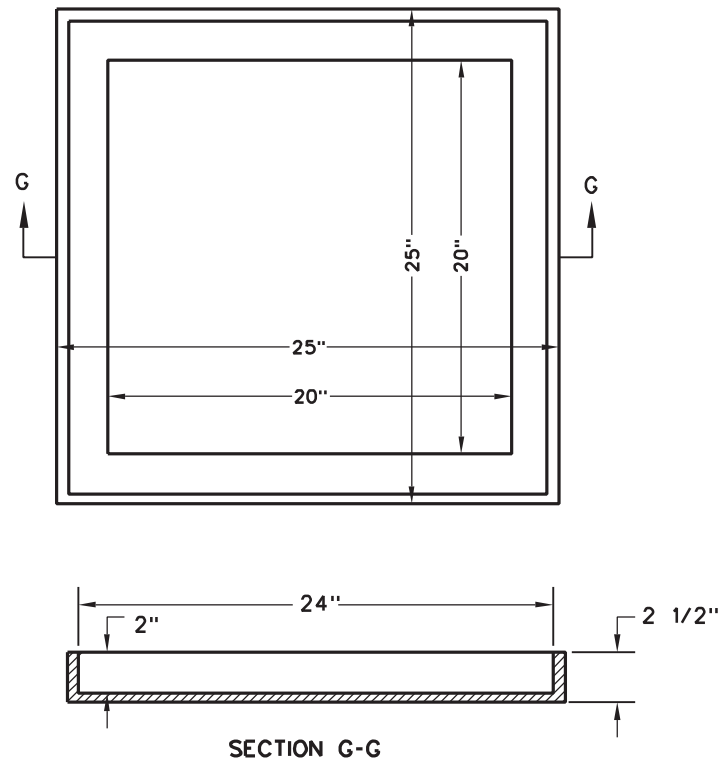

SECTION G-G
SINGLE-GRATE SHALLOW FRAME

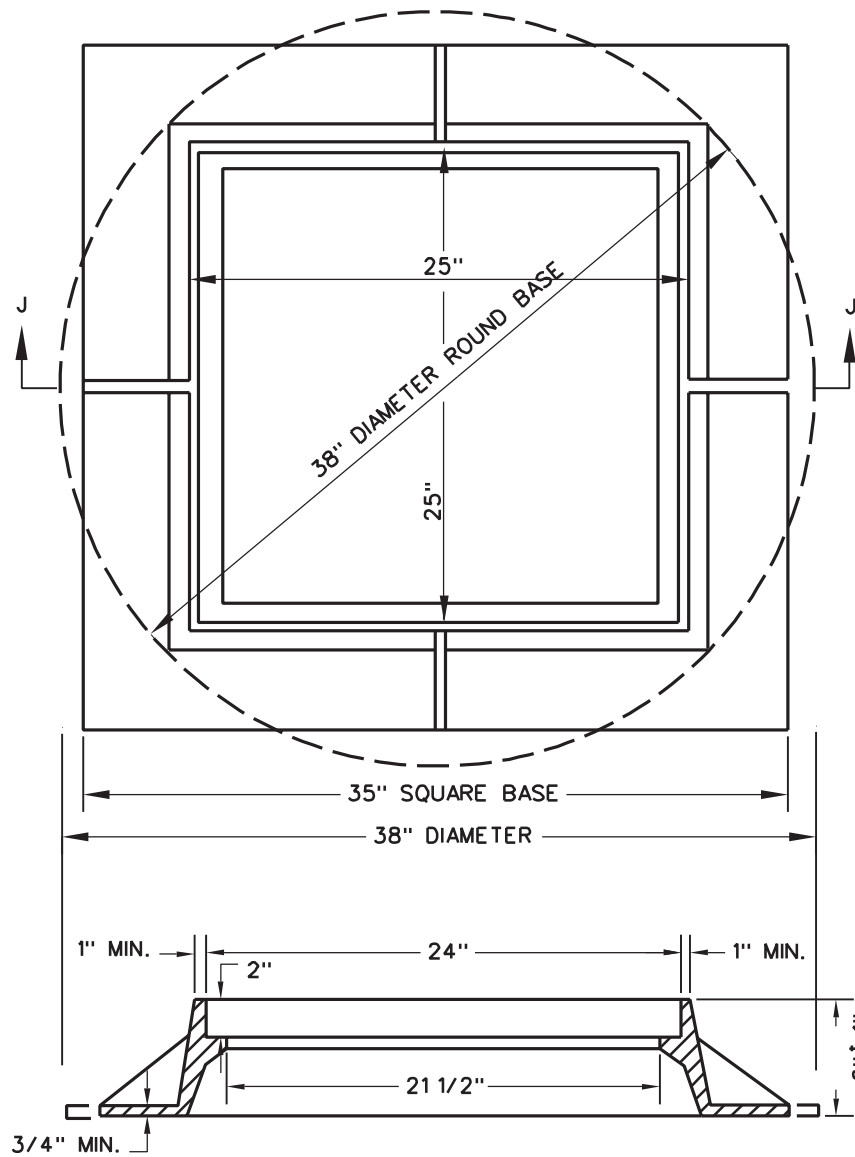

SECTION J-J
SINGLE-GRATE DEEP FRAME
(ROUND OR SQUARE BASE)

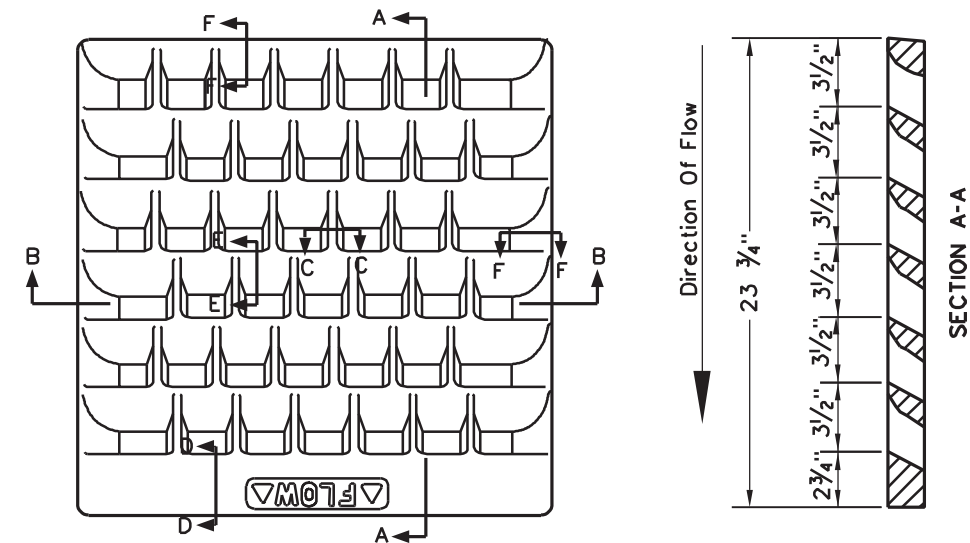

SECTION B-B
SECTION A-A

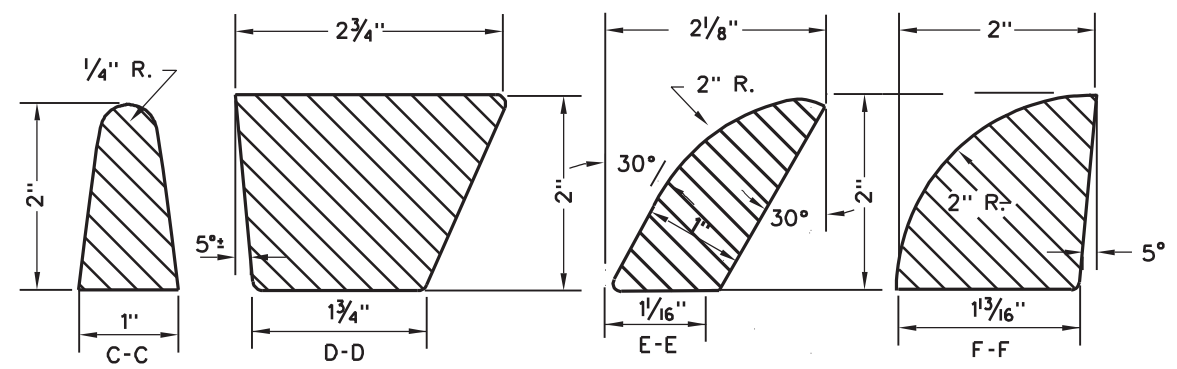

ENLARGED SECTIONS
TILT-BAR GRATE

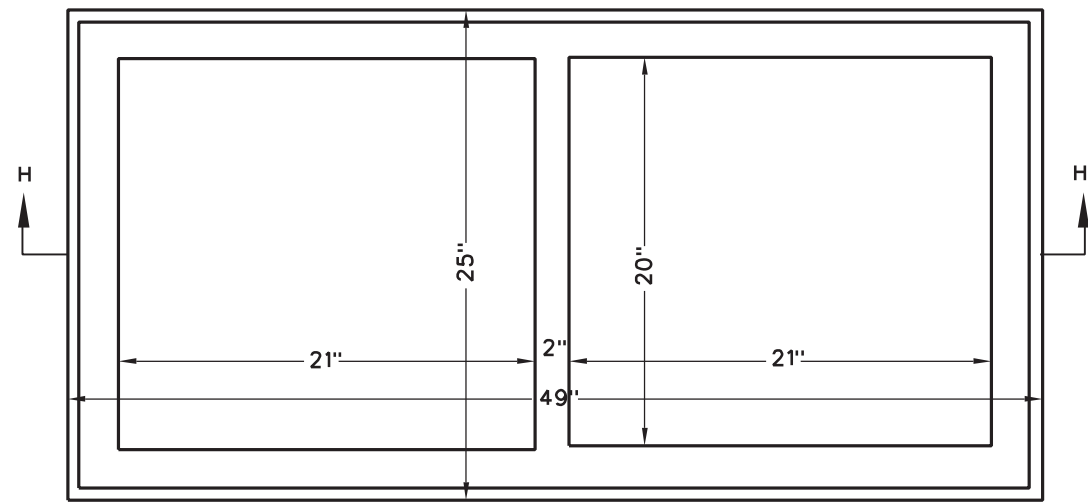

SECTION H-H
DOUBLE-GRATE SHALLOW FRAME

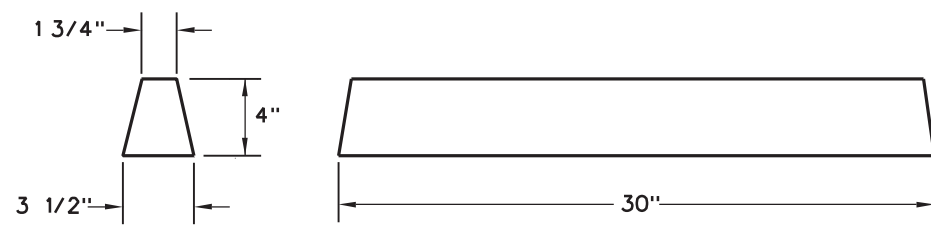
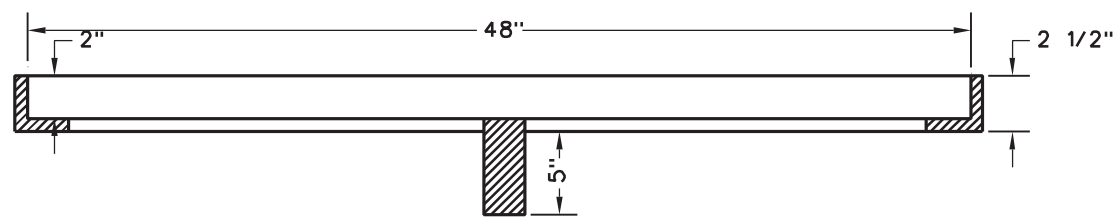

GRATE SUPPORT BAR

WEST VIRGINIA DEPARTMENT OF TRANSPORTATION
DIVISION OF HIGHWAYS
STANDARD DETAIL

PREPARED 7-1-99
REVISION DATE

INLET CASTINGS

STANDARD SHEET DR6-X

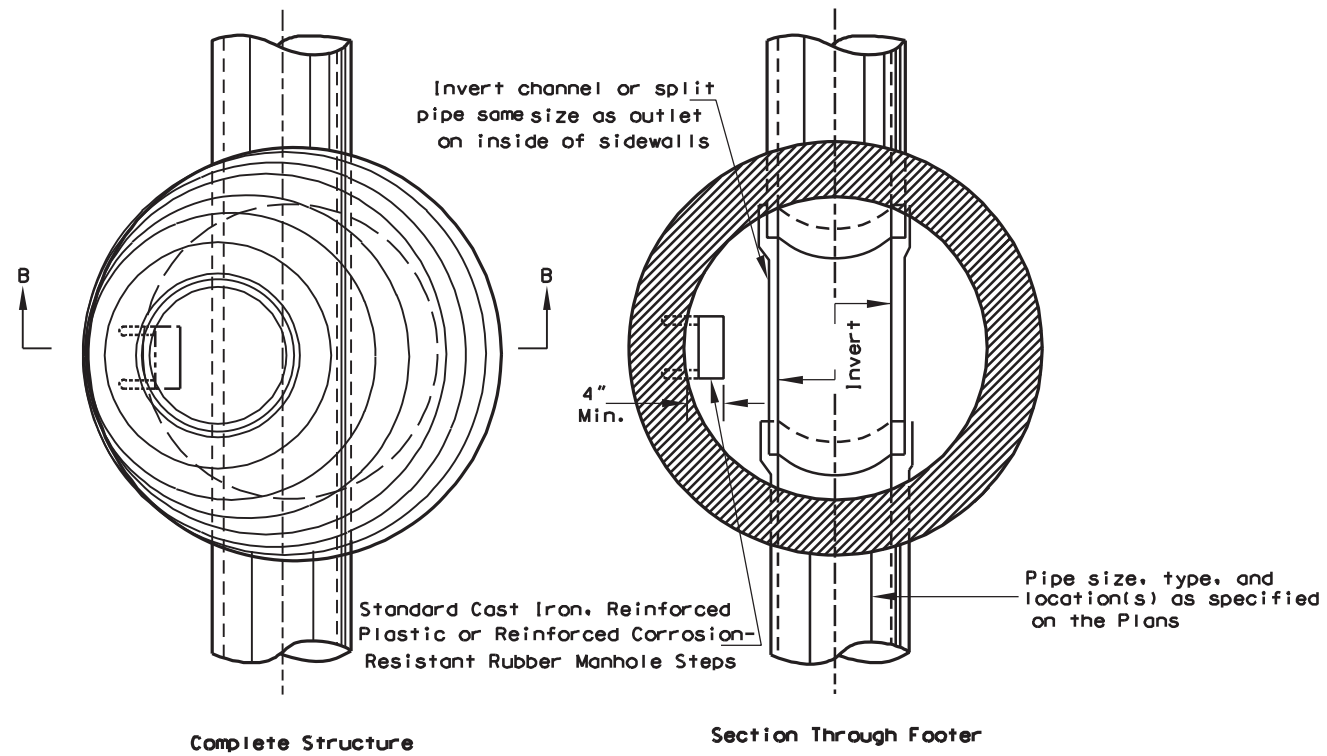

PLAN VIEWS

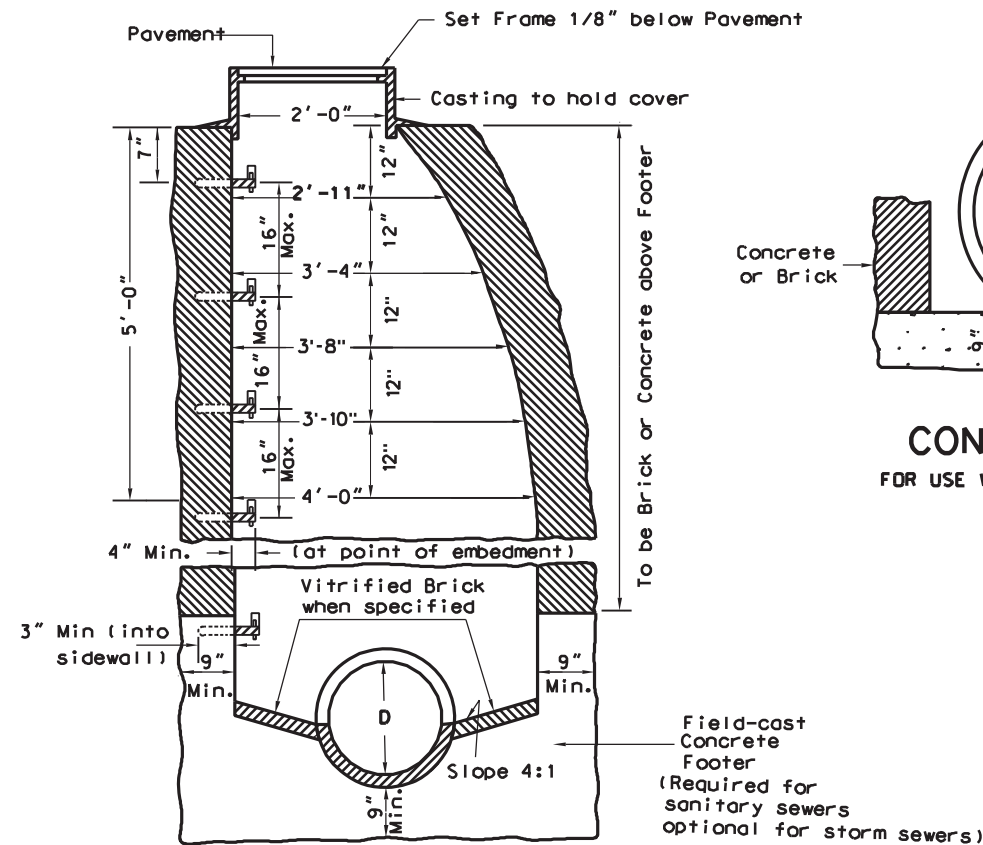

**Section B-B
CAST-IN-PLACE OPTION**

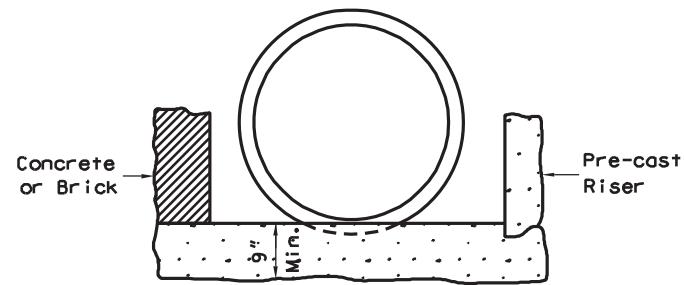

**CONCRETE BASE
FOR USE WITH STORM SEWERS ONLY
May Be Precast**

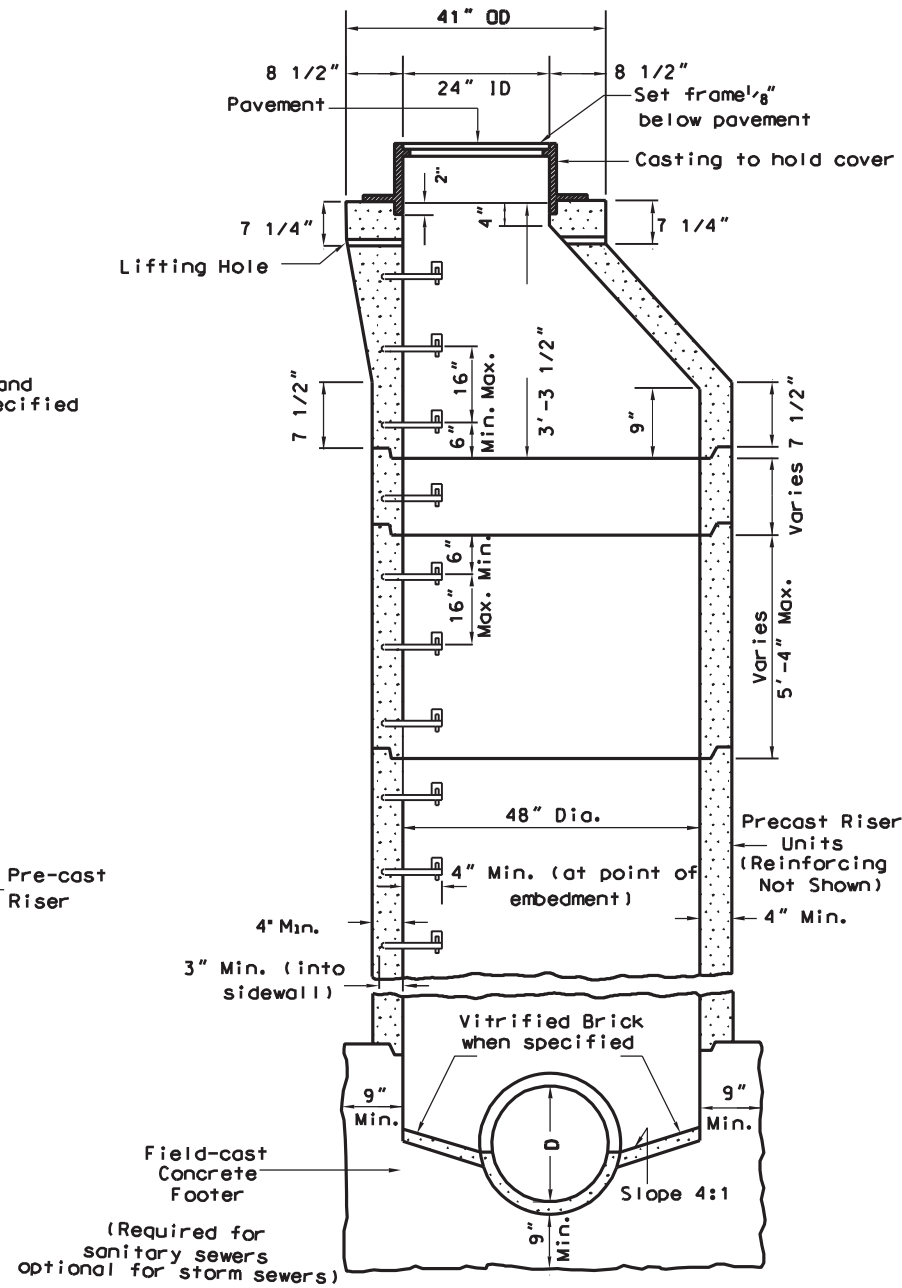

**Section B-B
PRE-CAST**

NOTES

Type A Manholes, when specified on the Plans, may be constructed in either method (cast-in-place or pre-cast option) as shown herein.

Steps, frames, and covers shall be as shown on Standard Sheet DR7-X.

"Keyed" or "doweled" type construction joints, acceptable to the Engineer, may be used in the construction of concrete manholes.

If the cast-in-place manhole is over twelve feet (12') in depth, the sidewalls below that depth will be double thickness.

Pipe at elevations other than shown may be joined to the manhole by cutting a hole the size of the connecting pipe in the manhole, inserting the pipe the thickness of the manhole shell and closing all openings around the connecting pipe with joint mortar.

Drawing shows pipe entering and leaving manhole in a straight line. However, the pipes may enter or leave at an angle or place as called for or shown on the Plans.

Minimum height of bench wall above flowline of pipe is 25% of the diameter of the pipes.

The use of brick for manhole construction will not be allowed when a manhole is located in the roadway.

The following additional notes are applicable for pre-cast manholes:

Manhole steps shall be placed into plastic concrete wall during manufacture or mortared into holes after the concrete has set.

Sidewall sections may be used in any combination to produce a manhole of desired depth, except the tapered top section shall be retained as shown.

The tapered top section shall be manufactured and meet the same requirements as the manhole's sidewalls, but shall conform to the dimensions detailed herein.

Lifting holes in the tapered top section and the circumferential notches in the manhole cover are for handling purposes only.

The pre-cast sidewall units shall be set in joint mortar or sealed with O-ring gaskets.

WEST VIRGINIA DEPARTMENT OF TRANSPORTATION
DIVISION OF HIGHWAYS
STANDARD DETAIL

PREPARED 7-1-99
REVISION DATE

TYPE A MANHOLE

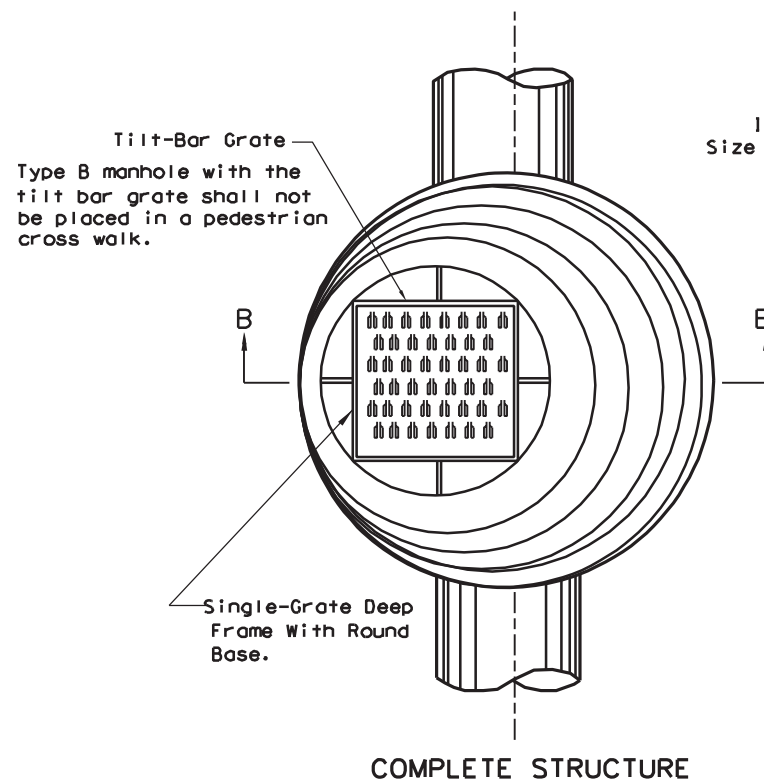

COMPLETE STRUCTURE

Invert Channel Or Split Pipe Same Size As Outlet On Inside Of Sidewalls.

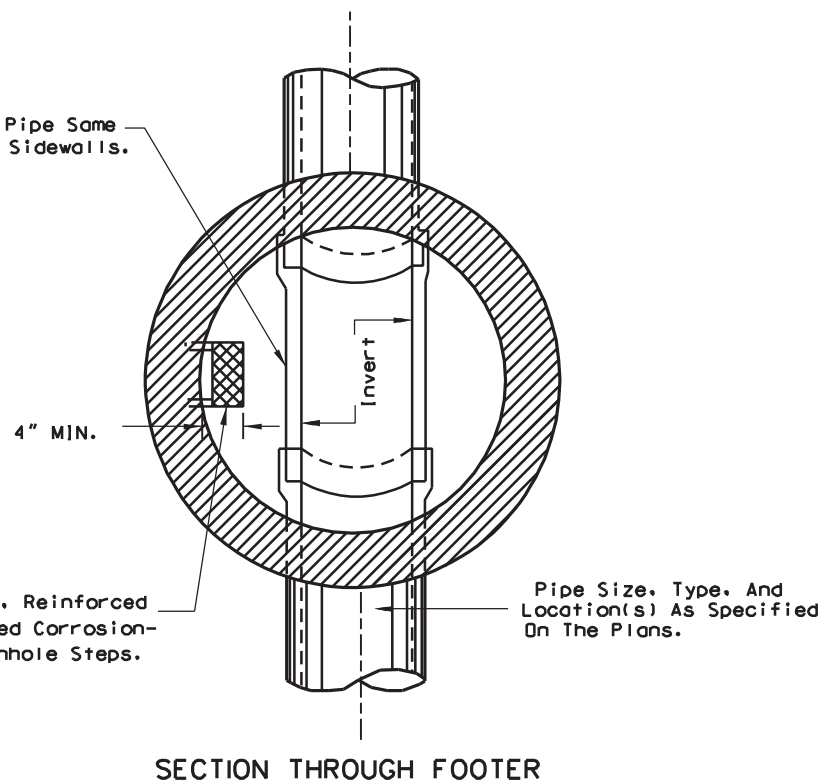

SECTION THROUGH FOOTER

Standard Cast Iron, Reinforced Plastic Or Reinforced Corrosion-Resistant Rubber Manhole Steps.

Pipe Size, Type, And Location(s) As Specified On The Plans.

PLAN VIEWS

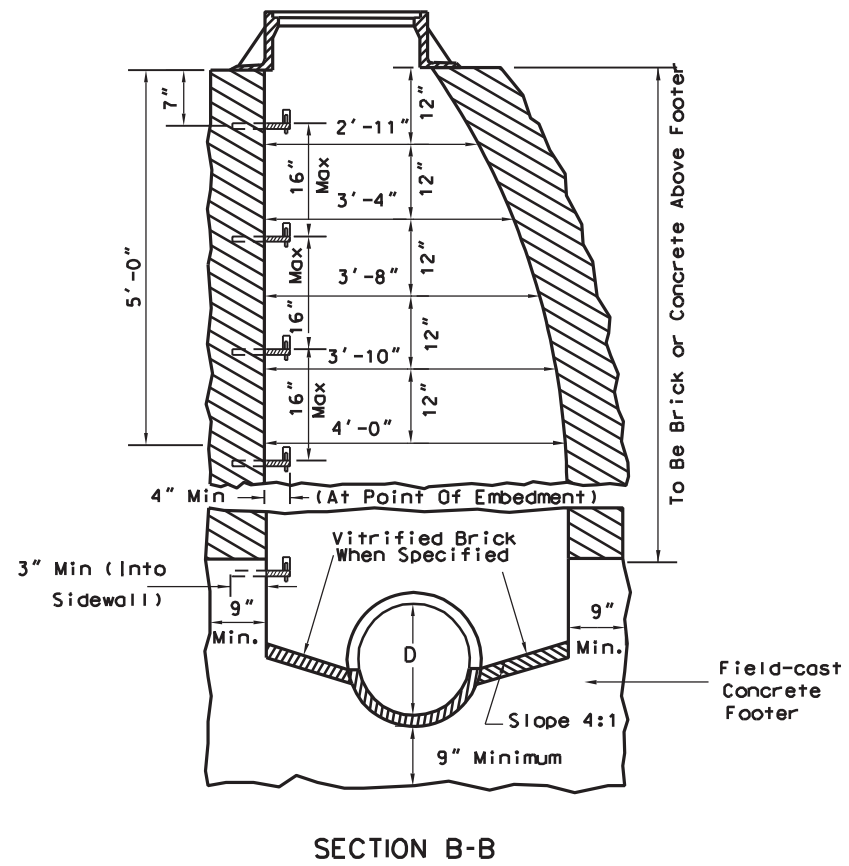

SECTION B-B

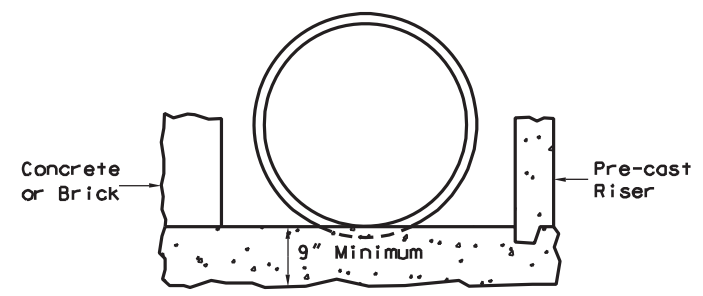

CONCRETE BASE
Optional Precast Or Field-cast
(For Use With Storm Sewers Only)

NOTES

"Keyed" Or "Doweled" Type Construction Joints, Acceptable To The Engineer, May Be Used In The Construction Of Concrete Manholes.

If Cast-In-Place Manhole Is Over Twelve Feet (12') In Depth. The Sidewalls Below That Depth Will Be Double Thickness.

Pipe At Elevations Other Than Shown May Be Joined To The Manhole By Cutting A Hole The Size Of The Connecting Pipe In The Manhole, Inserting The Pipe The Thickness Of The Manhole Shell And Closing All Openings Around The Connecting Pipe With Joint Mortar.

Either This Manhole Or The Precast Manhole On Standard Sheet DR7-A May Be Furnished When Type B Manhole Is Called For In The Contract. The Frame And Grate Shall Be As Shown On Standard Sheet DR6-X INLET CASTINGS. Steps Shall Be As Shown On Standard Sheet DR7-X.

Minimum Height Of Bench Wall Above Flowline Of Pipe Is 25% Of The Diameter Of The Pipes.

The use of brick for manhole construction will not be allowed when a manhole is located in the roadway.

WEST VIRGINIA DEPARTMENT OF TRANSPORTATION
DIVISION OF HIGHWAYS
STANDARD DETAIL

PREPARED 7-1-99
REVISION DATE

TYPE B MANHOLE

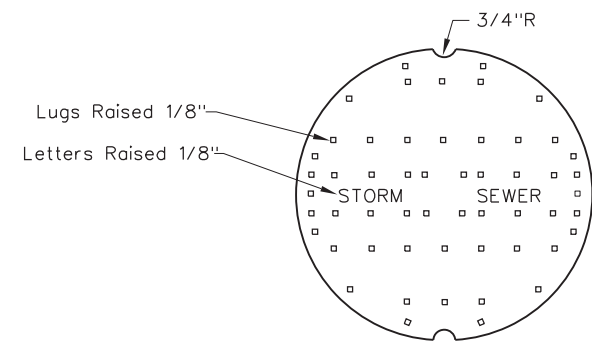

PLAN

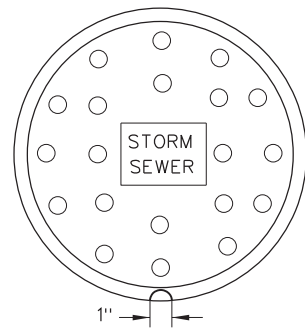

PLAN

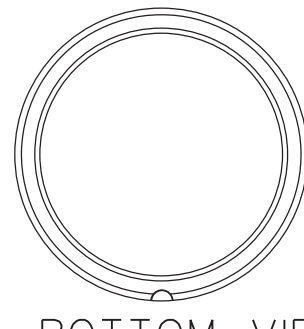

BOTTOM VIEW OF COVER

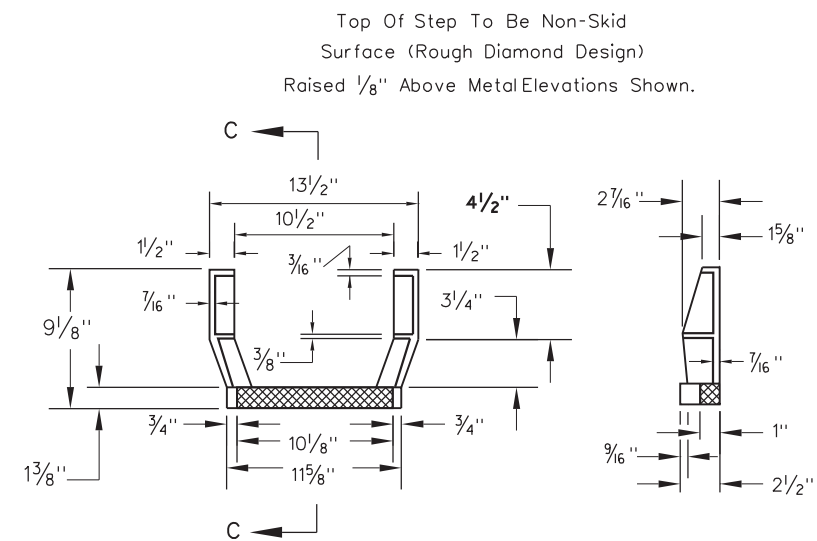

PLAN SECTION C-C
GRAY IRON STEP

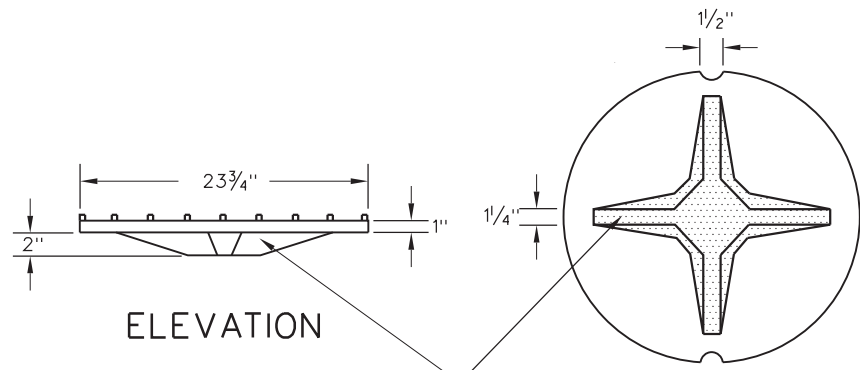

ELEVATION

INVERTED PLAN

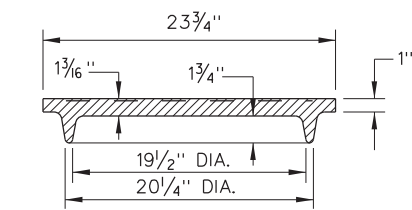

COVER SECTION

ALTERNATE MANHOLE COVER

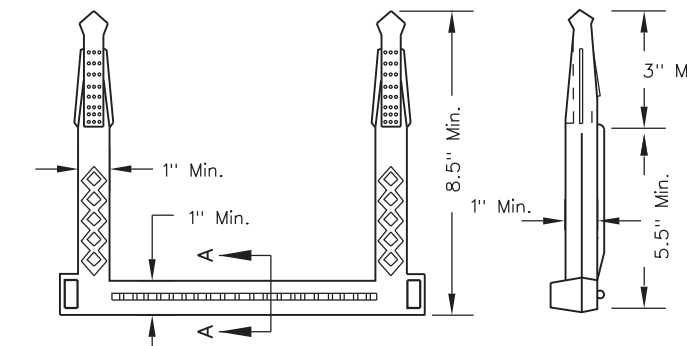

SECTION A-A
(Enlarged)

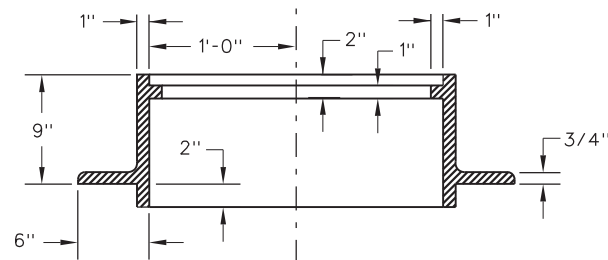

SECTION
MANHOLE FRAME

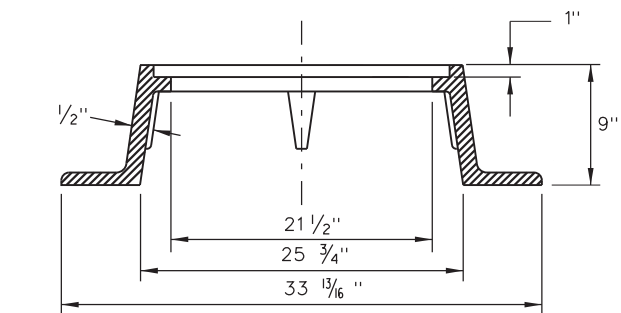

SECTION
ALTERNATE MANHOLE FRAME

REINFORCED PLASTIC AND REINFORCED -
CORROSION RESISTANT RUBBER MANHOLE STEPS

NOTES

- Lettering on covers shall denote STORM SEWER or SANITARY SEWER as applicable.
- Bottom ribs may be deleted from manhole cover castings.
- The 1/8" raised lugs are a skid resistant measure. Alternative measures will require approval by the Engineer.
- Shop Drawings shall be submitted if details and dimensions vary.

WEST VIRGINIA DEPARTMENT OF TRANSPORTATION
DIVISION OF HIGHWAYS
STANDARD DETAIL

MANHOLE CASTINGS

STANDARD SHEET DR7-X

PREPARED	7-1-99
REVISION DATE	3/7/11

* Except for structural plate pipe where length of bedding arc need not exceed width of bottom plate. However, if structural plate pipe is first assembled and then placed in the trench, the 0.15 O.D. minimum value will apply.

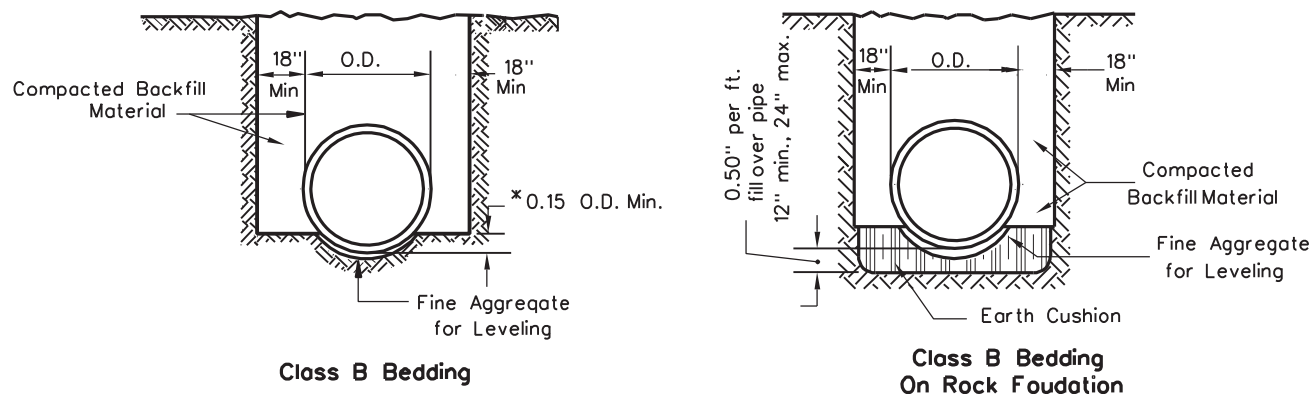

(Trench shown is for 18" thru 54" Pipe)

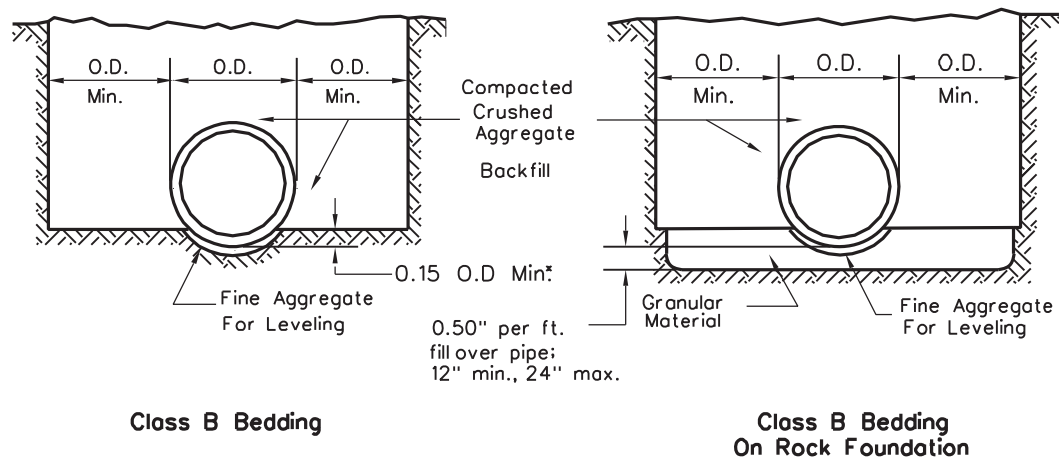

(Trench shown is for 60" thru 108" flexible pipe in soil cut fill sections)

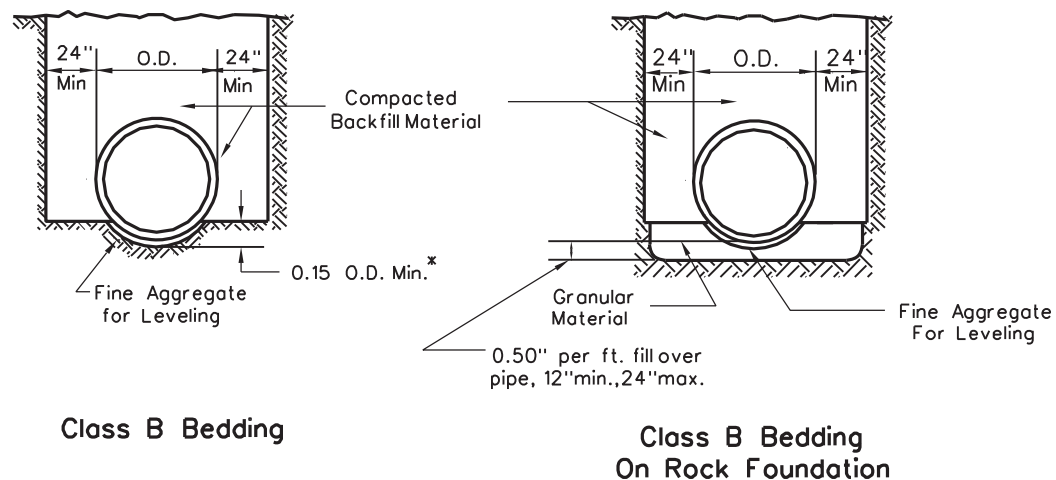

(Trench shown is for 60" thru 108" rigid pipe in cut sections)

TYPICAL PIPE BEDDING

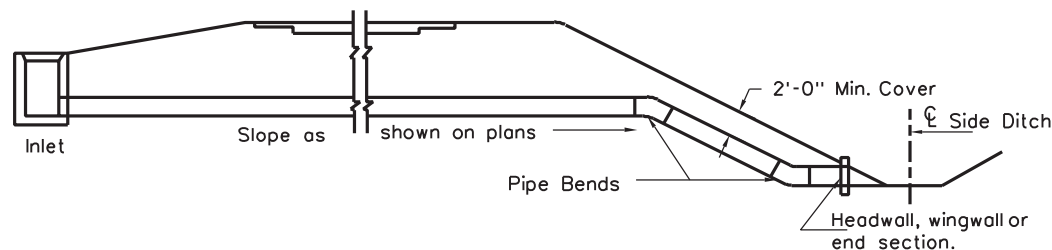

MEDIAN OUTLET IN HIGH FILL
To be used where called for on the plans or as shown on the cross sections.

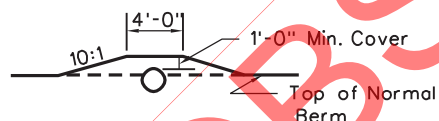
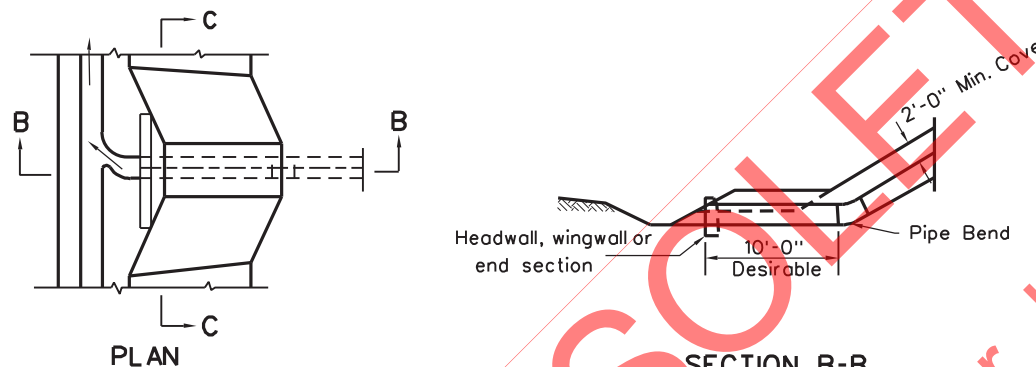

OUTLET THROUGH BERM
To be used where called for on the plans or as shown on the cross sections.

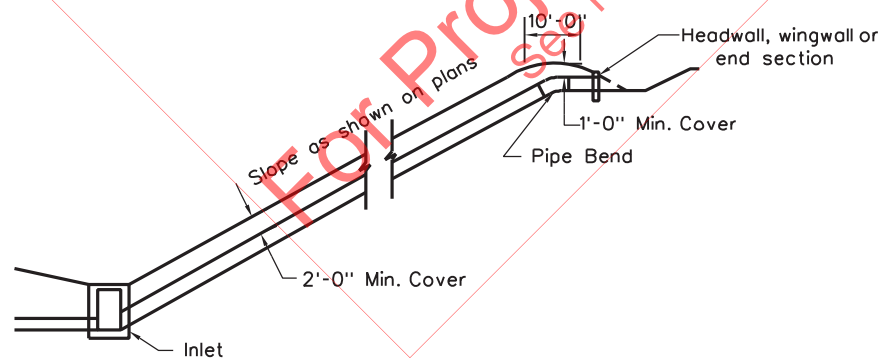

PIPE FLUME
Earth Cut or Shallow Rock Cuts

NOTES

For pipe without corrugations, a one inch layer of fine aggregate for leveling will normally be adequate to achieve a uniform bearing surface. For corrugated pipe, layers shall be 1" minimum for 1/2" depth corrugations, 2" minimum for 1" depth corrugations, and 3" minimum for 2" or 2-1/2" depth corrugations.

WEST VIRGINIA DEPARTMENT OF TRANSPORTATION
DIVISION OF HIGHWAYS
STANDARD DETAIL

PREPARED 7-1-99
REVISION DATE

MISCELLANEOUS DRAINAGE
(sheet 1 of 4)

STANDARD SHEET DR8

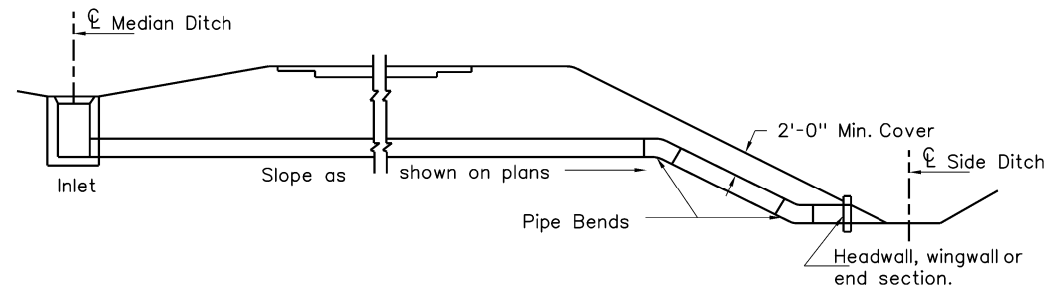

MEDIAN OUTLET IN HIGH FILL
To be used where called for on the plans or as shown on the cross sections.

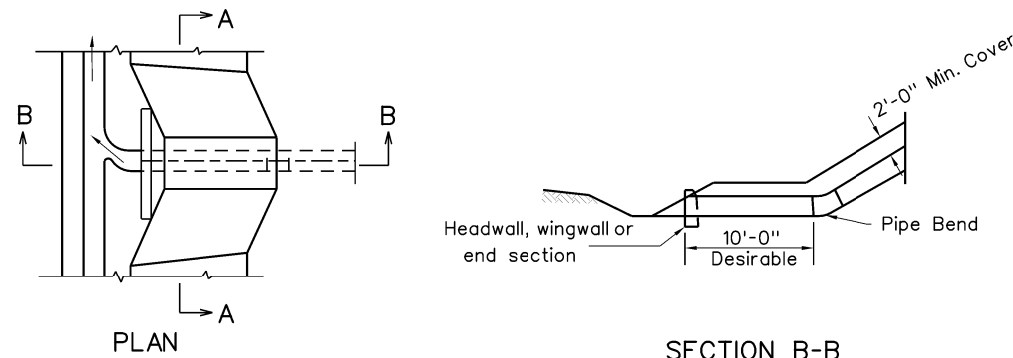

PLAN

SECTION B-B

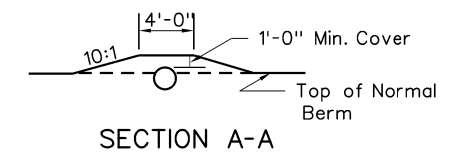

SECTION A-A

OUTLET THROUGH BERM
To be used where called for on the plans or as shown on the cross sections.

NOTES

Pipe bedding and backfill material in accordance with Section 604.
Crushed Aggregate shall be in accordance with 704.6, Class 1 or Class 3.
Granular Material shall be in accordance with 716.1.1.2.
The bedding material under the middle 1/3 of pipe diameter shall be loosely placed and uncompacted, for cradling of the pipe bottom.
Bedding outside of the middle 1/3 shall be compacted.

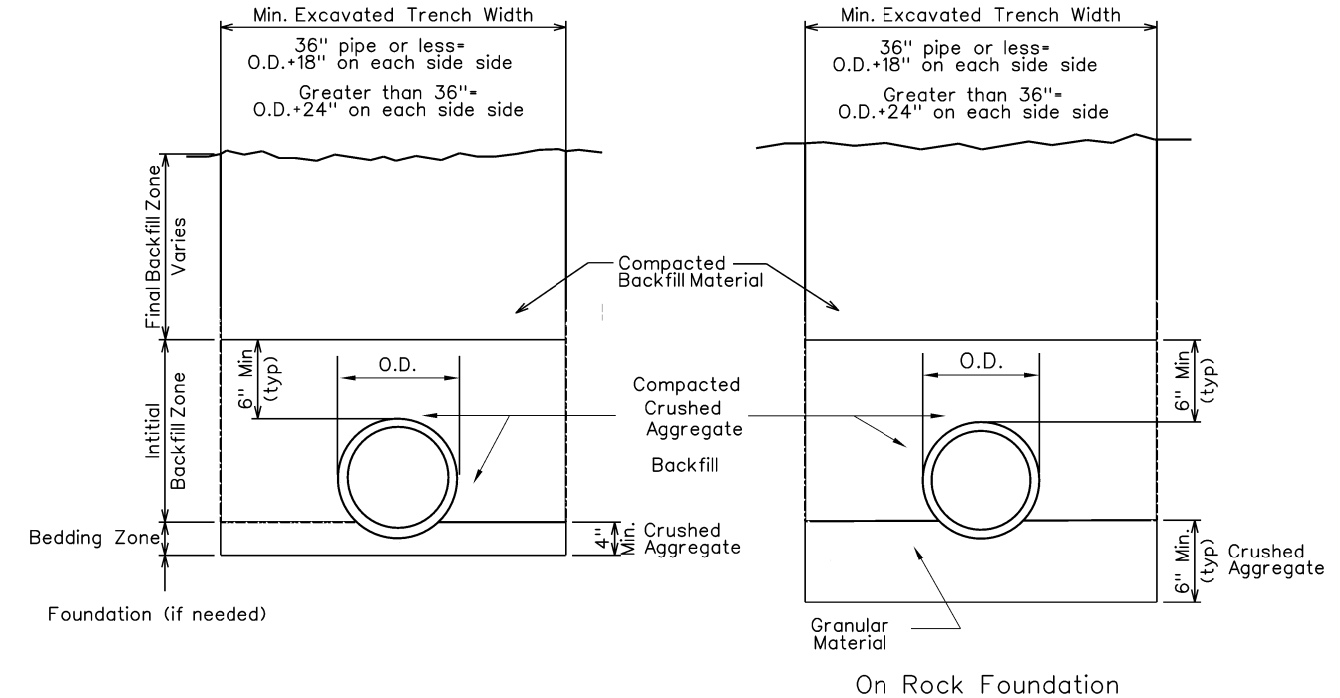

FLEXIBLE PIPE TYPICAL (96" OR LESS)

On Rock Foundation

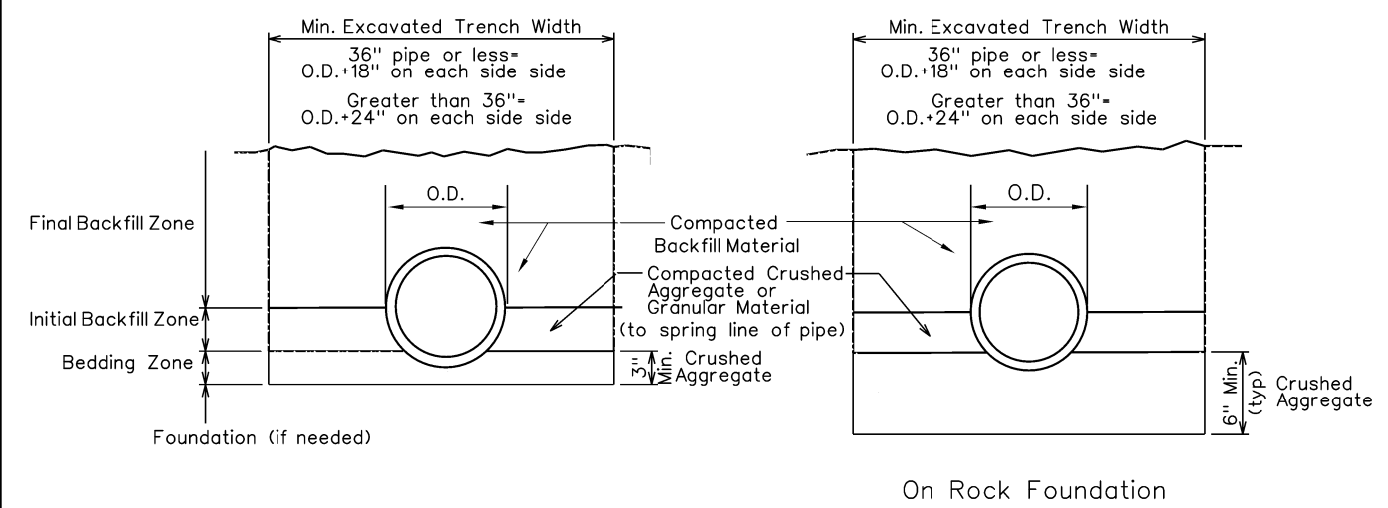

RIGID PIPE TYPICAL (96" OR LESS)

On Rock Foundation

PIPE INSTALLATION TYPICAL

WEST VIRGINIA DEPARTMENT OF TRANSPORTATION DIVISION OF HIGHWAYS STANDARD DETAIL	
REVISION DATE 5/2/19	MISCELLANEOUS DRAINAGE (sheet 1 of 4)
STANDARD SHEET DR8	

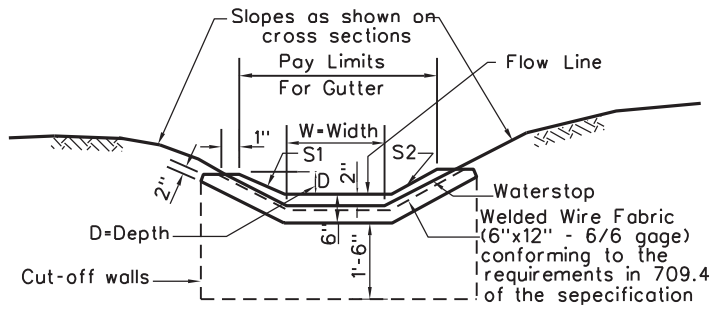

CONCRETE GUTTER

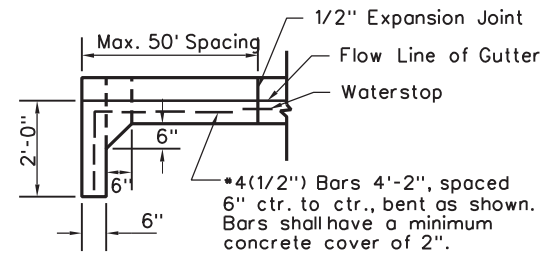

CUT - OFF WALL

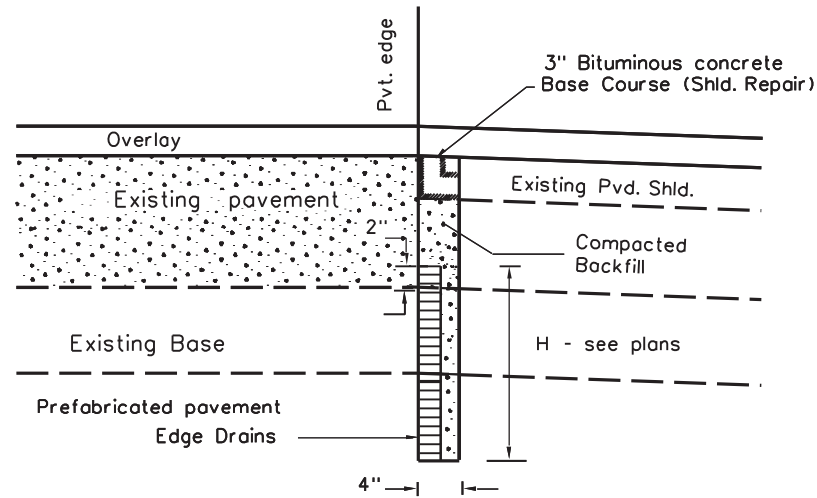

SECTION A-A

NOTES

Waterstop shall be 5" wide min; web min. thickness $\frac{3}{16}$ "; end section and / or ribs less than 1.67 web thickness.

The waterstop diagrams are for informational purposes only. All waterstops shall conform to the general shape shown and meet the requirements of Section 708.10 of the Specifications.

Concrete gutter types, depths and widths shall be specified on the plans and shall conform with the table shown. Only one concrete gutter type and depth shall be used in each individual run of gutter.

The "Concrete Gutter Treatment at Inlets" detail as shown is for transitioning a V ditch section to the width of the inlet. The 15' length is to be used to make this transition regardless of the width of the approach ditch.

Cut-off walls for concrete gutter shall be constructed and paid for in accordance with Section 633 of the Specifications.

There will be no separate payment for Select Embankment Channel if the material is obtained from the unclassified excavation. If select embankment is not available from unclassified excavation, payment will be made under Section 211 for Rock Borrow Excavation. Unless otherwise specified on the plans, the maximum rock size will be "T" and the minimum rock size will be one-half "T".

All edge drain outlets are to be equipped with a Slopewall for Underdrain and Varmint Screen as detailed on Standard Sheet DR8, 3 of 4 or tied to existing inlets or pipes. Underdrain pipe tied to inlets or fastened to culvert pipe by pipe saddle, grouting, cementing, or other means that will provide a secure attachment satisfactory to the engineer shall be included in the cost of the underdrain pipe. The cost of the Slopewall or tie to inlet or pipe will be included in the unit price bid for edge drain.

When edge drain outlets can not be outletted at 90° or 45° to pavement edge as shown, appropriate details as shown for Free Draining Base outlet on Standard Sheet DR8, 3 of 4 are to be used.

STANDARD CONCRETE GUTTER TYPES			
Gutter Type	Gutter Side Slopes		Gutter Depths and Widths
	S1	S2	
1	2:1	2:1	Gutter depths shall be specified in 6-inch increments. Gutter widths shall be in 1-foot increments for widths of two to six feet and in 2-foot increments for widths of over six feet. A change in width shall be transitioned at the rate of 1' in 10' each side.
2	4:1	2:1	
3	4:1	1-1/2:1	
4	6:1	2:1	
5	6:1	1-1/2:1	
6	5:1	5:1	
7	6:1	6:1	
8	4:1	4:1	

*Shall be inside gutter slope for roadside ditches, unless otherwise specified.

4" Non-Perforated Rigid Underdrain Pipe (Edge Drain Outlet)

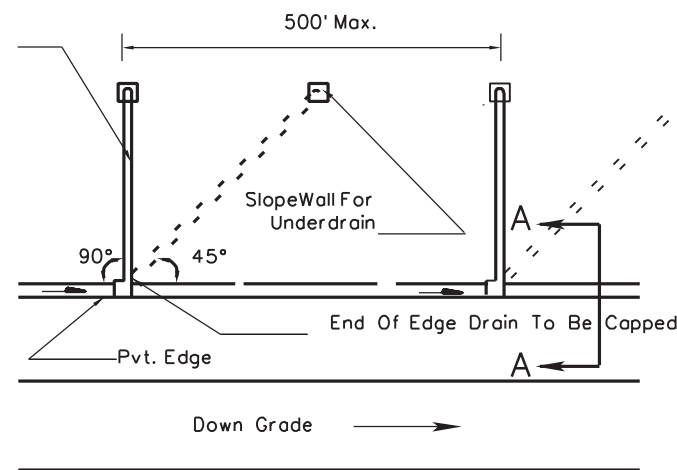

PLAN
PREFABRICATED EDGE DRAIN

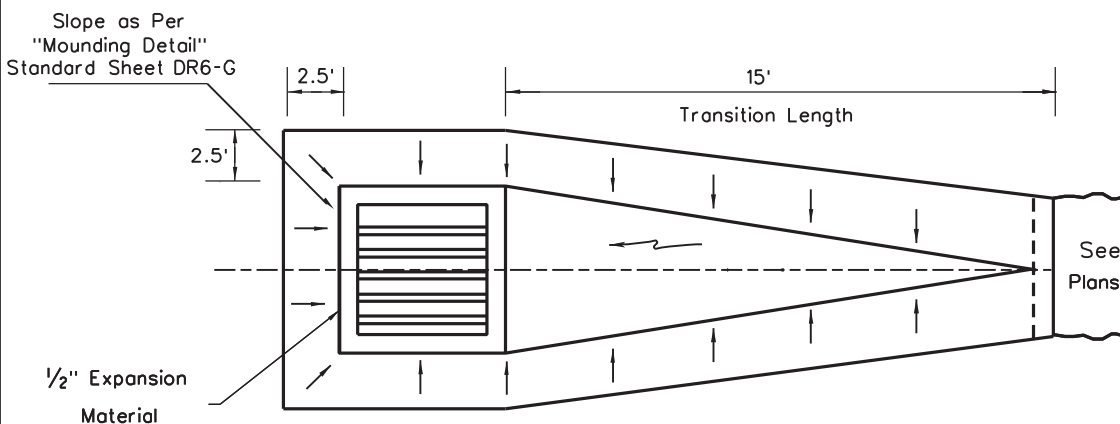

CONCRETE GUTTER TREATMENT AT INLETS
PLAN VIEW

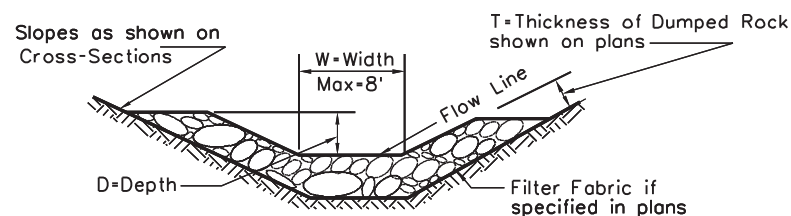
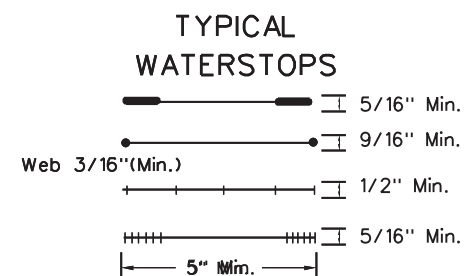

DUMPED ROCK GUTTER
(For Maximum Width of 8 Feet)
Stone sizes as per Section 704.4 of the Specifications

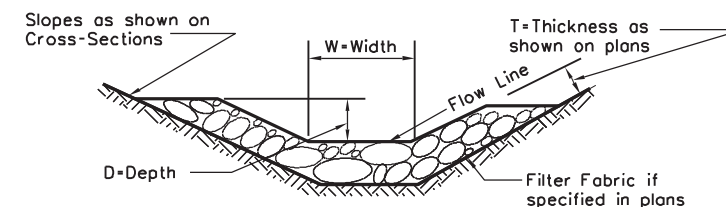

SELECT EMBANKMENT CHANNEL
(For Widths Exceeding 8 Feet)

WEST VIRGINIA DEPARTMENT OF TRANSPORTATION
DIVISION OF HIGHWAYS
STANDARD DETAIL

PREPARED 7-1-99
REVISION DATE

MISCELLANEOUS DRAINAGE
(sheet 2 of 4)

STANDARD SHEET DR8

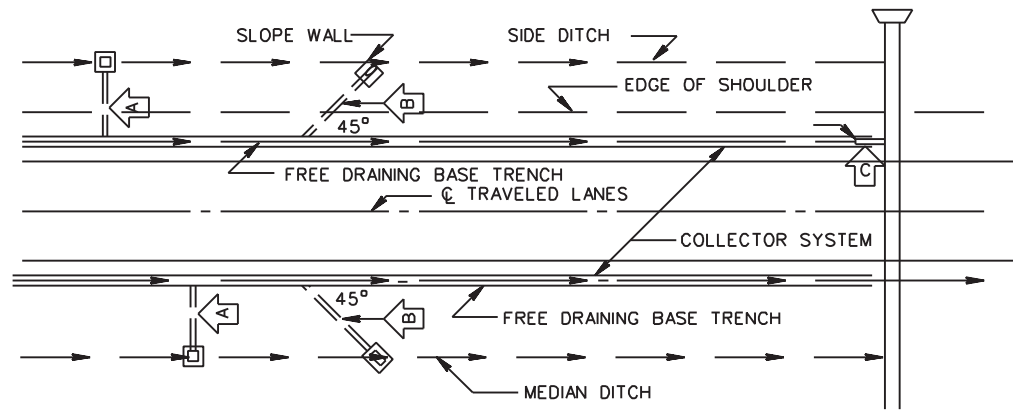

PLAN VIEW

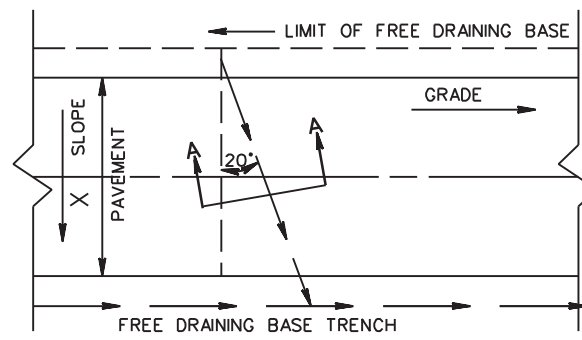

PLAN VIEW

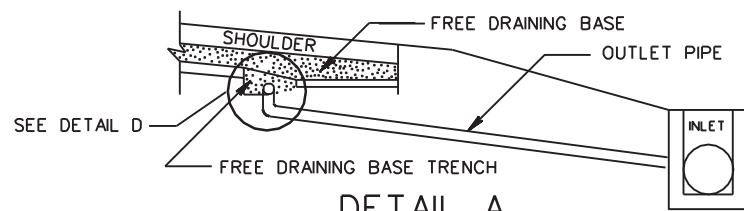

DETAIL A
(ELEVATION)

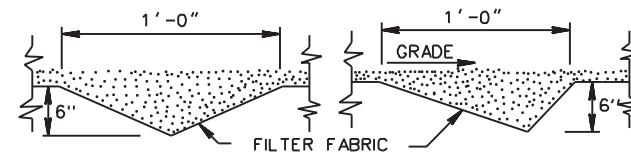

SECTION A-A
TYPICAL LATERAL TRENCH SECTION
FREE DRAIN BASE

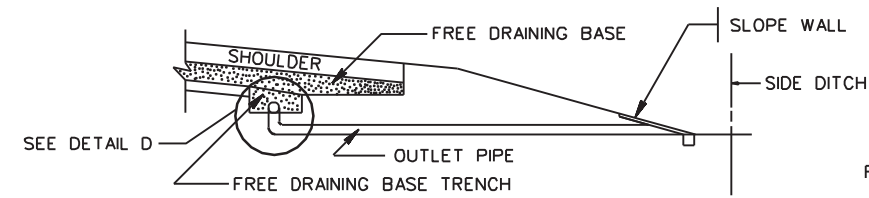

DETAIL B
(ELEVATION)

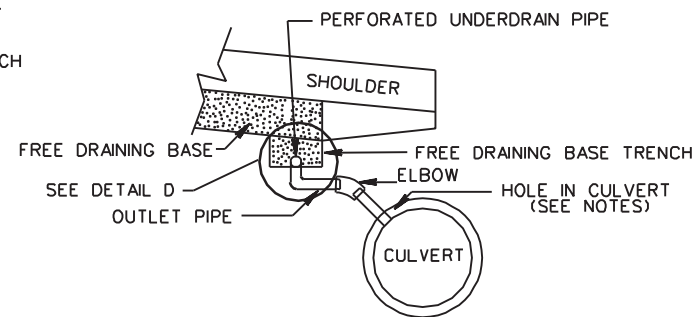

DETAIL C
(ELEVATION)

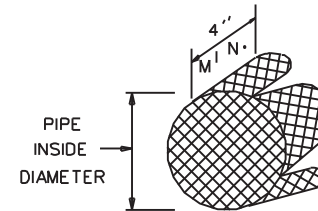

VARMINT SCREEN

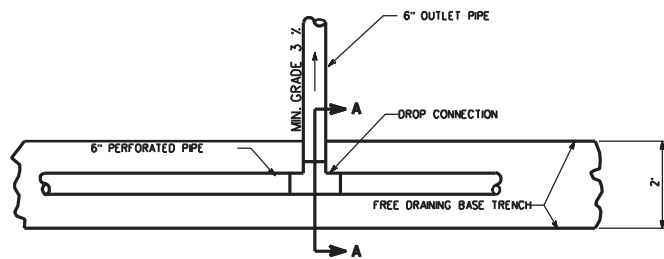

PLAN VIEW

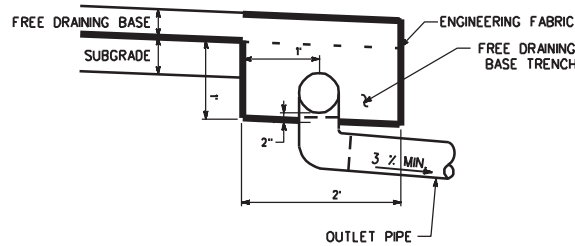

DETAIL D

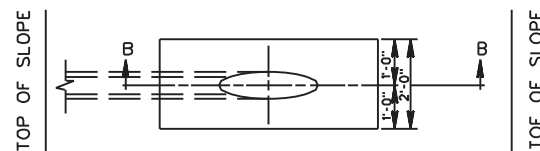

PLAN

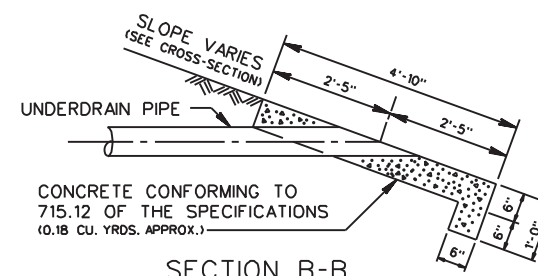

SECTION B-B
SLOPEWALL FOR UNDERDRAIN

NOTES

Payment for the outlet pipe includes drop connections in the free draining base trench and slopewalls or connections to drainage structures as required. Maximum outlet spacing is to be 250' in embankments. Outlets in cut sections will be made to the nearest drainage structure. Slopewall details will be in accordance with Standard DR8 (sheet 3 of 4). At vertical sags, one outlet shall be constructed at the low point and additional outlets shall be constructed at 25 feet and 50 feet each way from the low point.

Underdrain pipe as detailed to be 6" diameter non-perforated rigid pipe except for the 5' of pipe placed in the free draining base trench unless otherwise specified in the plans.

All outlets are to be equipped with a Slopewall for Underdrain and Varmint Screen as detailed. Slopewalls will not be paid for separately but shall be included in the cost of the underdrain pipe. Underdrain pipe tied to inlets or fastened to culvert pipe by pipe saddle, grouting, cementing, or other means that will provide a secure attachment satisfactory to the engineer shall be included in the cost of the underdrain pipe.

Commercially available galvanized hardware screen is to be snugly fitted inside each Slopewall. The screen is to have the capability of being removed and reinstalled for maintenance operations. The screen wires shall be welded at a spacing in each direction of 3/8" to 5/8". The cost of the screen to be included in the cost of the underdrain pipe or edge drain.

Crossovers shall have outlets coordinated with regular roadway outlets to insure that all areas shall be free draining.

Typical lateral trench sections shown are possible selections, other configurations may be utilized if depth and width are obtained. Spacing shall be 100' maximum in areas designated as requiring lateral trench.

Lateral trench sections shall be installed at locations as follows:

- Cross Slope = 0.0156% Grade = 4% and above
- Cross Slope = 0.0208% Grade = 5% and above
- Cross Slope = 0.0400% Grade = 8% and above
- Cross Slope = 0.0600% and greater no trench required

WEST VIRGINIA DEPARTMENT OF TRANSPORTATION
DIVISION OF HIGHWAYS
STANDARD DETAIL

Prepared 7-1-99
REVISION DATE

MISCELLANEOUS DRAINAGE
(sheet 3 of 4)

STANDARD SHEET DR8

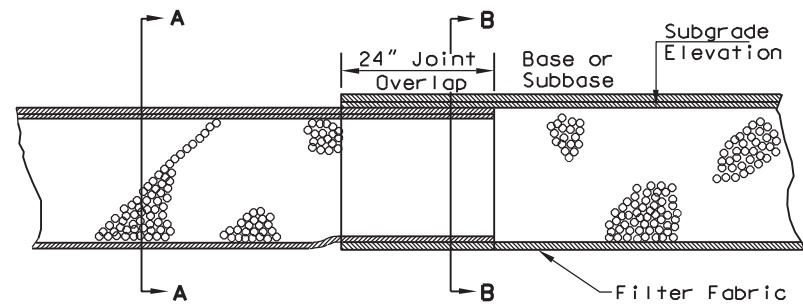

LONGITUDINAL ELEVATION VIEW

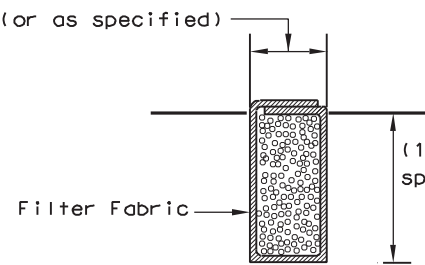

SECTION A-A

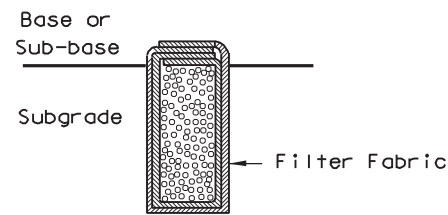

SECTION B-B

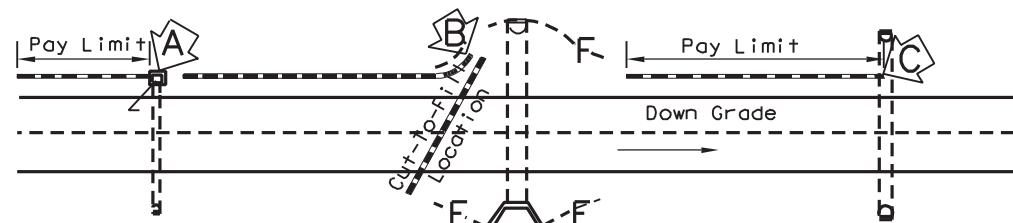

TYPICAL PLAN VIEW

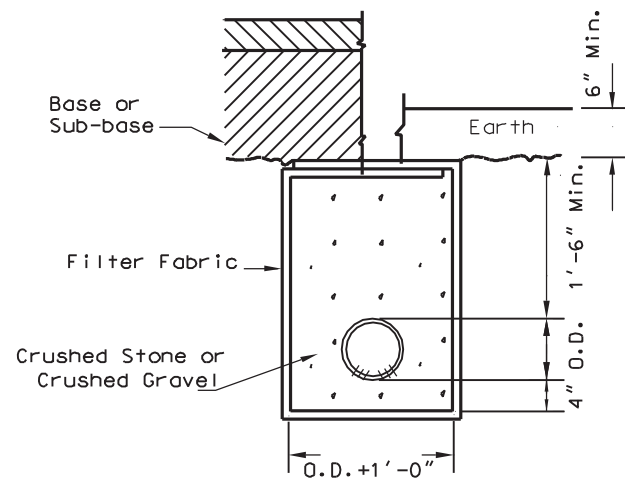

PIPE UNDERDRAIN SECTION

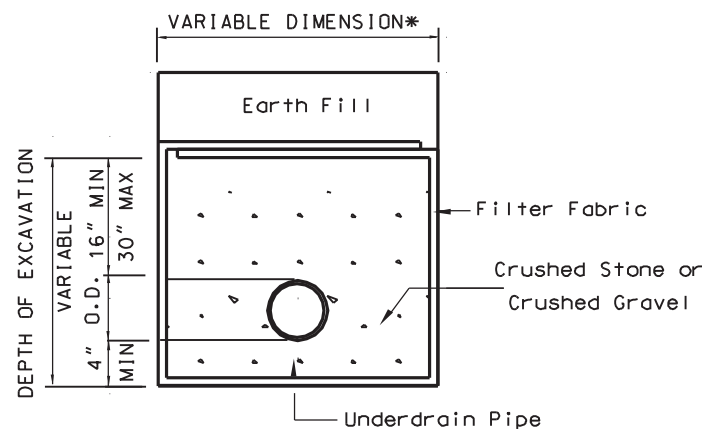

METHOD OF SPRING CONTROL (TYPICAL SECTION)

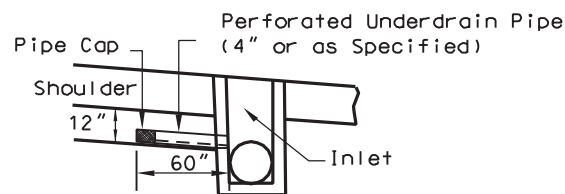

(Elevation View) DETAIL A

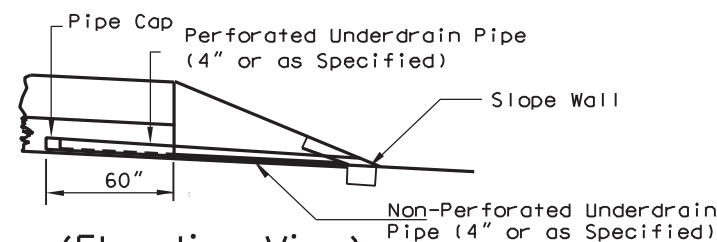

(Elevation View) DETAIL B

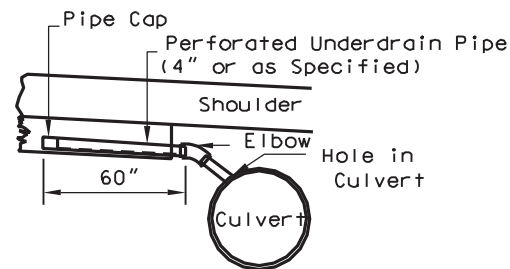

(Elevation View) DETAIL C

FILTER FABRIC UNDERDRAIN (Typical Installations)

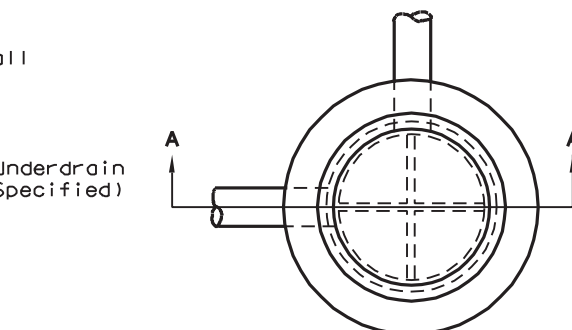

PLAN

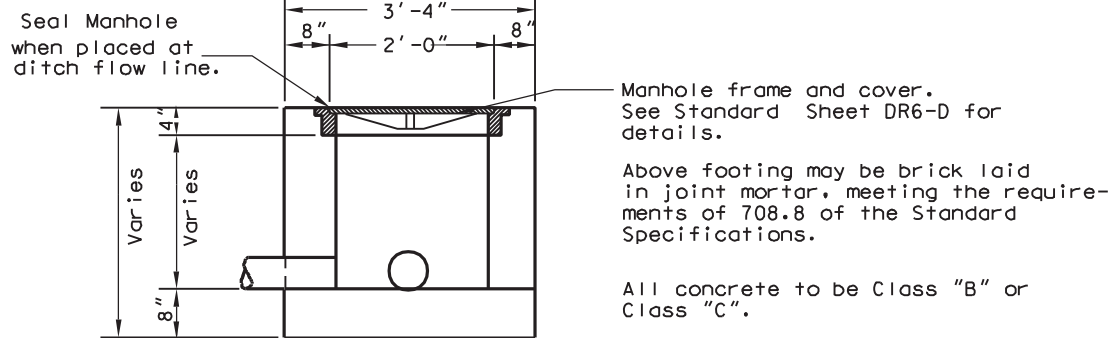

SECTION A-A UNDERDRAIN JUNCTION BOX

NOTES

Filter fabric and aggregate for filter fabric underdrain shall conform to the requirements of Section 606.2 of the Specifications. All costs associated with the 5' perforated Underdrain pipe required in the Filter Fabric Underdrain installation to be included in the contract price bid for Filter Fabric Underdrain.

Underdrain shall generally follow the grade of the pavement where the grade is not less than 1%. A desirable minimum of 1% and an absolute minimum of 0.5% with 18" of cover shall control in the placement of Underdrain unless otherwise noted on the plans.

The top of underdrain pipe shall be placed at the same elevation as the top of the outlet pipe at all Inlets or Manholes unless otherwise noted on the plans.

Spring Control shall be used where noted on the Plans or as directed by the Engineer. Cost of excavation, filter fabric and installation shall be included in the contract price bid for "Crushed Stone, Crushed Gravel, or Silica Sand for Underdrain." Dimensions as indicated variable shall be as shown on the plans or determined in the field.

For pipe cap detail, see Standard Sheet DR8, Sheet 3 of 4.

All Underdrain outlets are to be equipped with a Slopewall for Underdrain and Varmint Screen as detailed on Standard Sheet DR8, 3 of 4 or tied to existing inlets or culvert pipes. Slopewall for Underdrain will not be paid for separately but shall be included in the cost of the Underdrain pipe, or Filter Fabric Underdrain. Underdrain pipe tied to inlets or fastened to culvert pipe by pipe saddle, grouting, cementing, or other means that will provide a secure attachment satisfactory to engineer shall be included in the cost of the Underdrain pipe, or Filter Fabric Underdrain.

WEST VIRGINIA DEPARTMENT OF TRANSPORTATION
DIVISION OF HIGHWAYS
STANDARD DETAIL

PREPARED 7-1-99
REVISION DATE
MISCELLANEOUS DRAINAGE

(sheet 4 of 4)

STANDARD SHEET DR8

NOTES

1. The type of backfill and repaving of trenches under existing pavement shall be as specified in the plans. If no type is specified, the applicable detail shall be used. When a Type F Trench is specified under an existing roadway, repaving of the pavement section shall be per the applicable detail on this sheet.

2. Asphalt thickness shown here are in addition to any resurfacing which may be included in this project. Trench to be completed before resurfacing.

3. Type of stone to be same as specified for base on this project and payment to be in tons or C.Y. as specified in those items. If such stone is not specified, cost is to be included in the unit price of pipe and stone to meet requirements of Section 307 Class I.

4. Payment for asphalt to be in tons of material specified for the project. If such items are not specified cost is to be included in unit price of pipe. Asphalt base or patching and leveling may be used.

5. Cost of all labor, materials, and equipment required to complete the work to the surface of the existing pavement in accordance with the applicable detail(s) shall be included in the unit price for the pipe.

6. Where type A trenches are wider than 7' in existing bituminous pavement, concrete may be deleted if existing asphalt thickness and 18" stone are restored.

7. Traffic is to be maintained at all times by the use of appropriate traffic control devices. Use of metal plates, having sufficient rigidity to span trench, is required to prevent wheel loads from being transmitted to the CLSM or concrete. The plates are to be securely anchored to prevent movement caused by traffic. The plates are to be left in place until the CLSM has attained a 50% of its compressive strength. Cost of such plates is to be included in the unit price bid for pipe.

8. Concrete surface to be rough for bonding of asphalt if area is to be resurfaced. Trench to be completed before resurfacing.

9. Testing of steel bars & dowels is waived; however the Engineer must verify dimensions.

10. Concrete shall be constructed in accordance with Section 501 except that testing is waived if from a Certified Supplier.

11. Dowel bars are to be coated in accordance with Section 709.15 of the specifications.

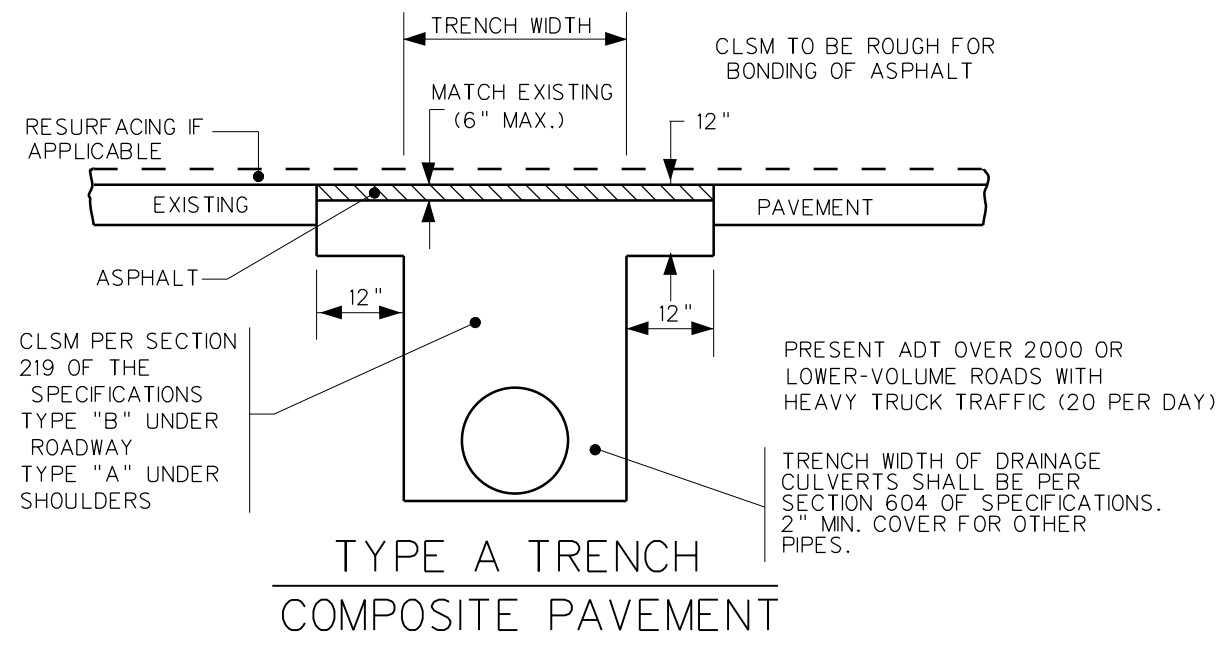

TYPE A TRENCH
COMPOSITE PAVEMENT

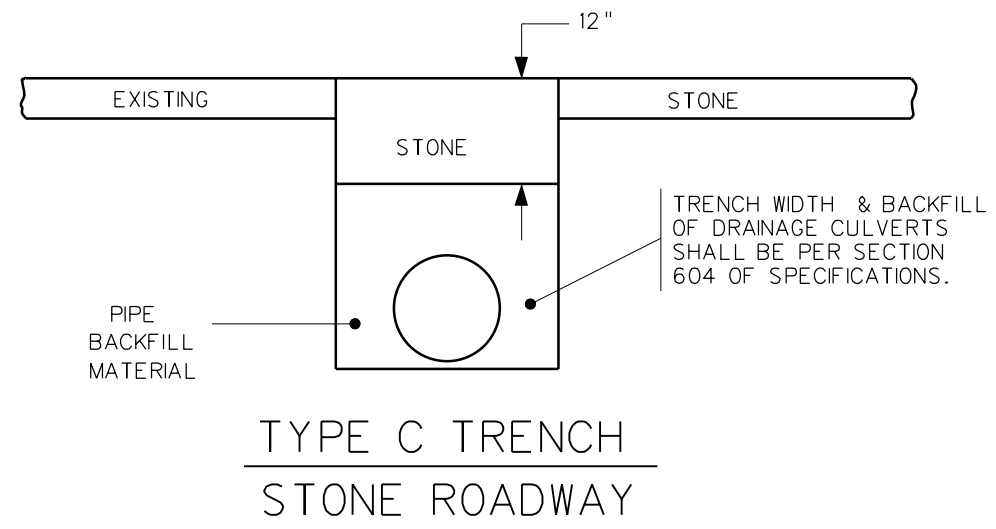

TYPE C TRENCH
STONE ROADWAY

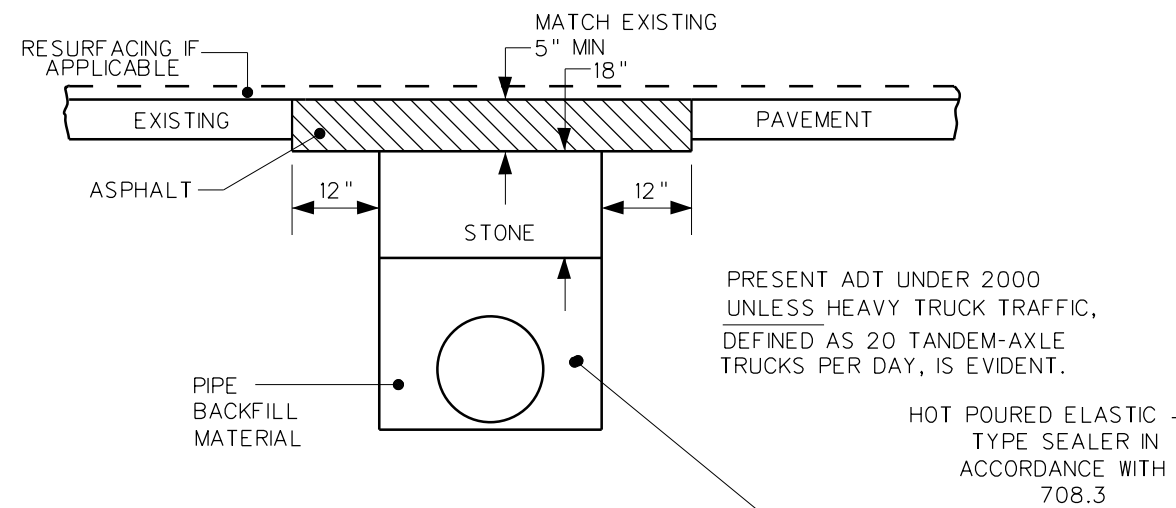

TYPE B TRENCH
ASPHALT PAVEMENT

1/4" x 18" DOWEL BARS AT 12" CENTERS AT MID SLAB. (USE WHEN TRENCH WIDTH IS GREATER THAN 6'.)

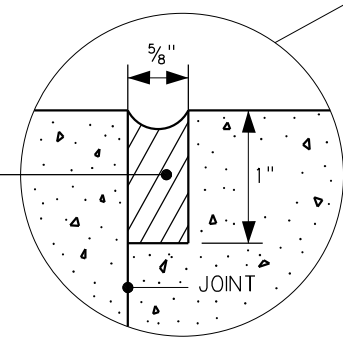

JOINT SEALER DETAIL

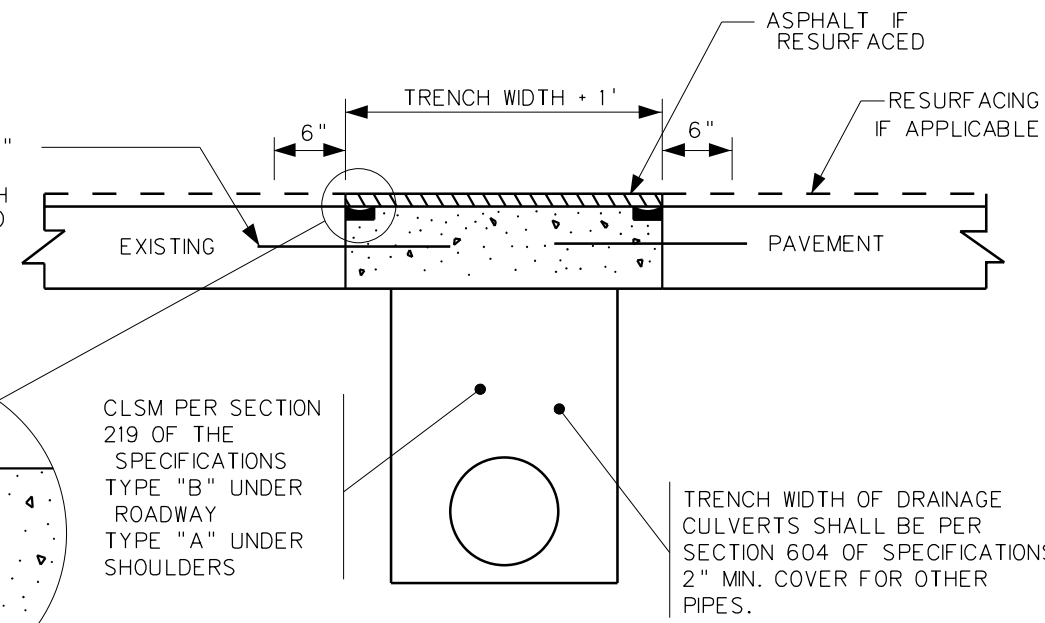

TYPE D TRENCH
CONCRETE PAVEMENT

WEST VIRGINIA DEPARTMENT OF TRANSPORTATION
DIVISION OF HIGHWAYS
STANDARD DETAIL

PREPARED 1/17/11
REVISION DATE
4/22/15

REPAVING TRENCHES
UNDER EXISTING
PAVEMENT

STANDARD DETAIL SHEET DR-9

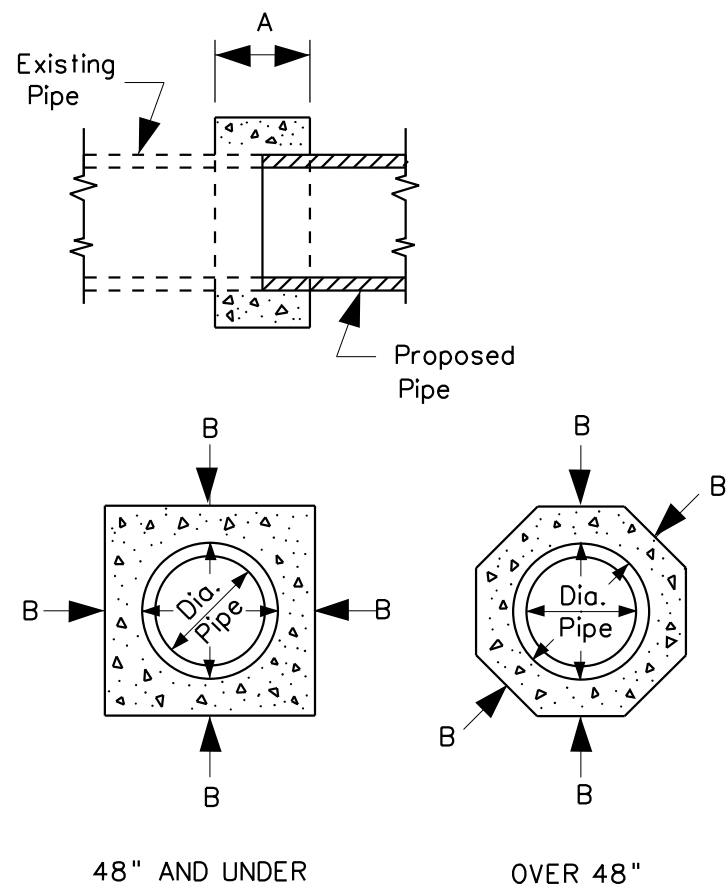

CONCRETE COLLAR DETAIL

DIAMETER OF PIPE	A	B	CU. YD. CONC. *	DIAMETER OF PIPE	A	B	CU. YD. CONC. *
15"	1'-0"	0'-6"	0.18	48"	2'-0"	1'-0"	2.10
18"	1'-0"	0'-6"	0.21	54"	2'-6"	1'-0"	2.09
21"	1'-0"	0'-6"	0.24	60"	3'-0"	1'-6"	4.31
24"	1'-0"	0'-6"	0.27	72"	3'-0"	1'-6"	5.03
30"	1'-6"	0'-9"	0.75	84"	3'-0"	2'-0"	7.94
36"	1'-6"	0'-9"	0.92	96"	3'-0"	2'-0"	8.90
42"	2'-0"	1'-0"	1.84	108"	3'-0"	2'-0"	9.87

* FOR INFORMATION ONLY

NOTES :

A AND B ARE MINIMUM DIMENSIONS. FORMING WILL NOT BE REQUIRED IF MINIMUM DIMENSIONS ARE OBTAINED. METAL CONNECTING BANDS MAY BE SUBSTITUTED FOR A CONCRETE COLLAR TO JOIN EXISTING NEW METAL PIPES. THE COST OF METAL BANDS ARE TO BE INCLUDED IN THE UNIT BID PRICE FOR THE VARIOUS PIPES.

CONCRETE FOR CONSTRUCTING THE COLLAR SHALL BE IN ACCORDANCE WITH SECTION 715.12 OF THE SPECIFICATIONS; HOWEVER, TESTING WILL NOT BE REQUIRED. THE COST OF CONCRETE COLLAR IS TO BE INCLUDED IN THE UNIT BID PRICE OF PROPOSED PIPE.

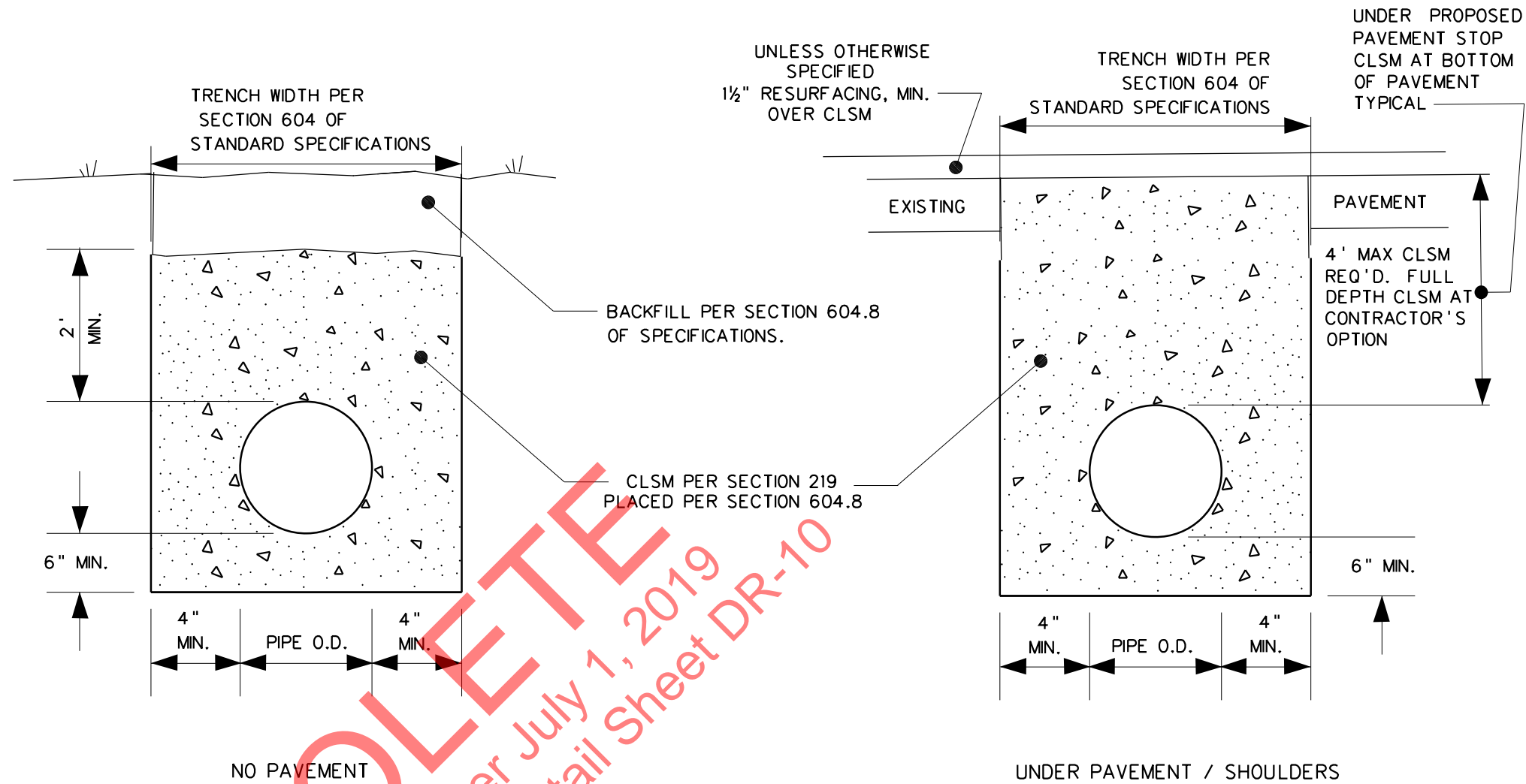

TYPE F DRAINAGE PIPE TRENCH

NOTES

CLSM - CONTROLLED LOW STRENGTH MATERIAL

THIS DETAIL SHALL BE USED ON PROPOSED PIPES / CULVERTS WHEN SPECIFIED ON THE PLANS. THE COST OF THE TYPE F TRENCH IS INCIDENTAL TO THE PIPE / CULVERT.

IF TYPE F TRENCH IS USED WHERE THERE IS NO EXISTING OR PROPOSED INLET, THE CLSM SHALL BE POURED FULL DEPTH 2' PAST EACH EDGE OF PAVEMENT. THE PIPE SHALL BE ENCASED IN 4" OF CLSM AN ADDITIONAL 10' MAX. BEYOND EDGE OF PAVEMENT IF THERE IS AN EXISTING OR PROPOSED NLET THE CLSM SHALL BE POURED FULL DEPTH TO THE INLET.

WEST VIRGINIA DEPARTMENT OF TRANSPORTATION
DIVISION OF HIGHWAYS
STANDARD DETAIL

PREPARED 1/7/11
REVISION DATE
10/10/13
4/22/15

TYPE F DRAINAGE
PIPE TRENCH,
CONCRETE COLLAR

STANDARD DETAIL SHEET DR-10

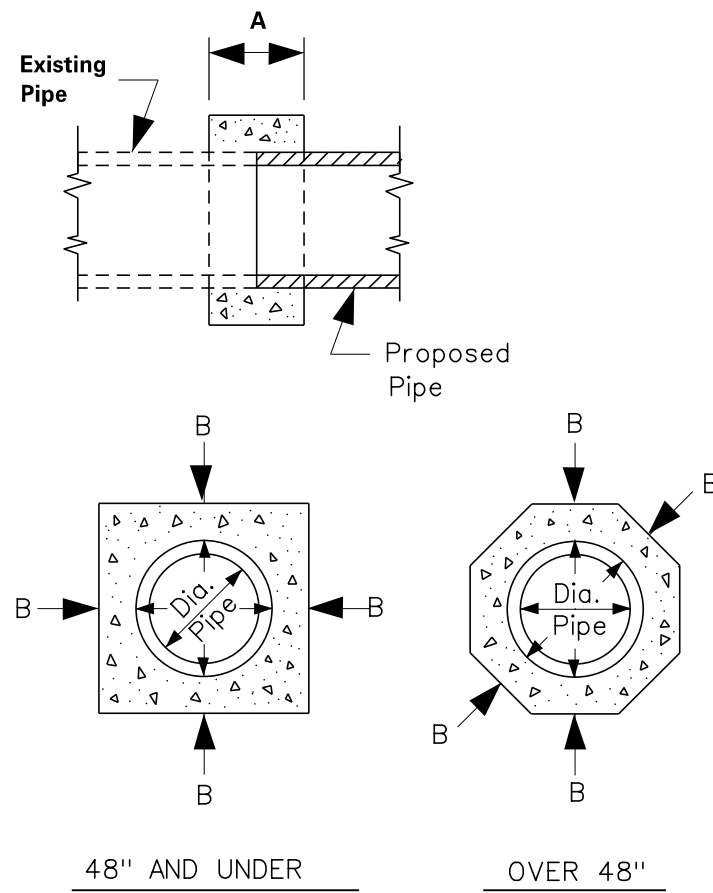

48" AND UNDER

OVER 48"

CONCRETE COLLAR DETAIL

DIAMETER OF PIPE	A	B	CU. YD. CONC. *	DIAMETER OF PIPE	A	B	CU. YD. CONC. *
15"	1'-0"	0'-6"	0.18	48"	2'-0"	1'-0"	2.10
18"	1'-0"	0'-6"	0.21	54"	2'-6"	1'-0"	2.09
21"	1'-0"	0'-6"	0.24	60"	3'-0"	1'-6"	4.31
24"	1'-0"	0'-6"	0.27	72"	3'-0"	1'-6"	5.03
30"	1'-6"	0'-9"	0.75	84"	3'-0"	2'-0"	7.94
36"	1'-6"	0'-9"	0.92	96"	3'-0"	2'-0"	8.90
42"	2'-0"	1'-0"	1.84	108"	3'-0"	2'-0"	9.87

* FOR INFORMATION ONLY

NOTES :

A AND B ARE MINIMUM DIMENSIONS. FORMING WILL NOT BE REQUIRED IF MINIMUM DIMENSIONS ARE OBTAINED. METAL CONNECTING BANDS MAY BE SUBSTITUTED FOR A CONCRETE COLLAR TO JOIN EXISTING NEW METAL PIPES. THE COST OF METAL BANDS ARE TO BE INCLUDED IN THE UNIT BID PRICE FOR THE VARIOUS PIPES.

CONCRETE FOR CONSTRUCTING THE COLLAR SHALL BE IN ACCORDANCE WITH SECTION 715.12 OF THE SPECIFICATIONS; HOWEVER, TESTING WILL NOT BE REQUIRED. THE COST OF CONCRETE COLLAR IS TO BE INCLUDED IN THE UNIT BID PRICE OF PROPOSED PIPE.

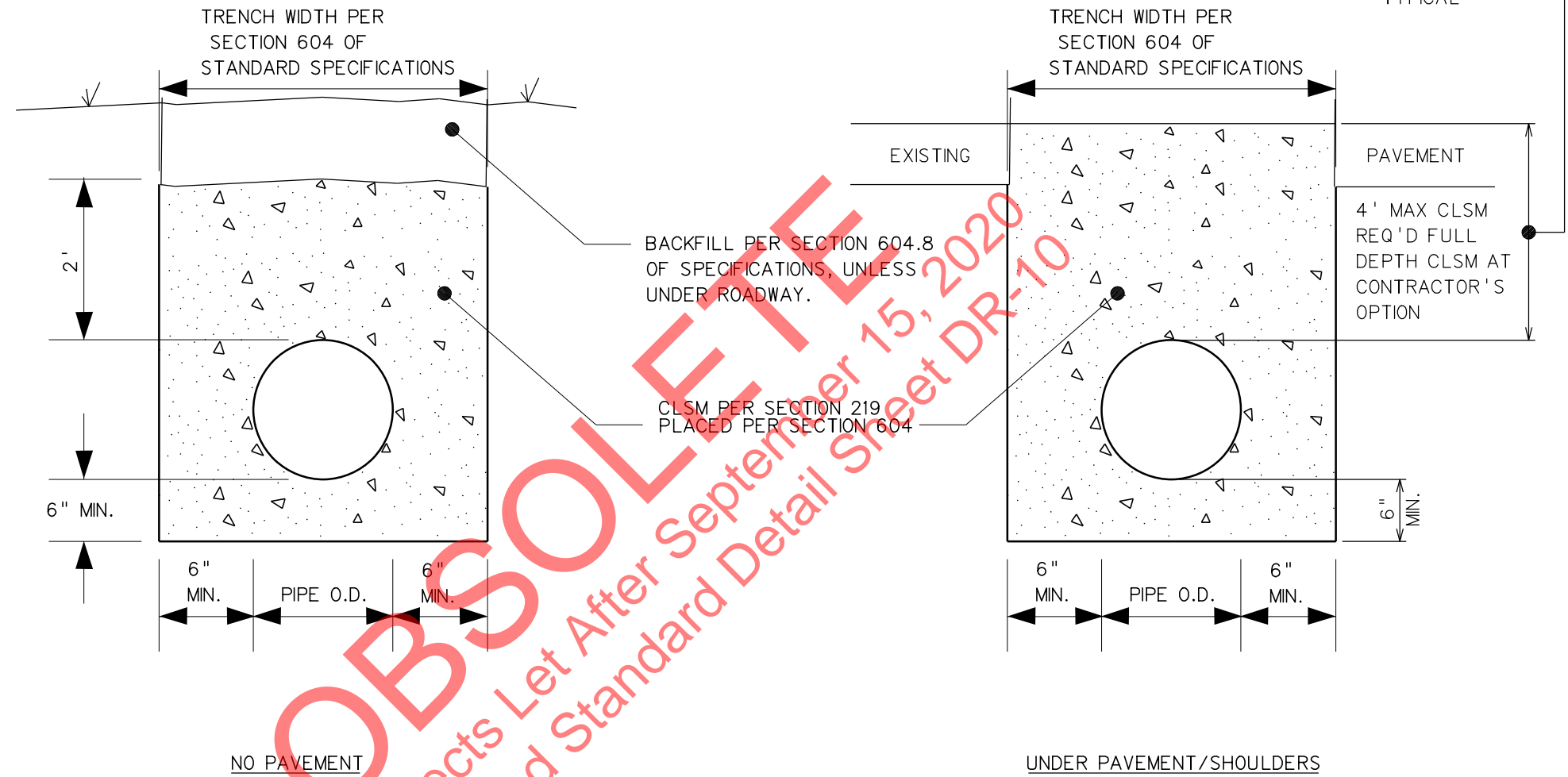

TYPE F DRAINAGE PIPE TRENCH

NOTES

CLSM - CONTROLLED LOW STRENGTH MATERIAL

THIS DETAIL SHALL BE USED ON PROPOSED PIPES / CULVERTS WHEN SPECIFIED ON THE PLANS. THE COST OF THE TYPE F TRENCH IS INCIDENTAL TO THE PIPE / CULVERT.

IF TYPE F TRENCH IS USED WHERE THERE IS NO EXISTING OR PROPOSED INLET, THE CLSM SHALL BE POURED FULL DEPTH 2' PAST EACH E.P. THE PIPE SHALL BE ENCASED IN 6" OF CLSM AN ADDITIONAL 10' MAX. BEYOND E.P. IF THERE IS AN EXISTING OR PROPOSED INLET THE CLSM SHALL BE POURED FULL DEPTH TO THE INLET.

WEST VIRGINIA DEPARTMENT OF TRANSPORTATION DIVISION OF HIGHWAYS STANDARD DETAIL	
STANDARD DETAIL	
PREPARED 1/7/11	
REVISION DATE	
10/10/13	
4/22/15	
10/3/18	
TYPE F DRAINAGE PIPE TRENCH, CONCRETE COLLAR	
STANDARD DETAIL SHEET DR-10	

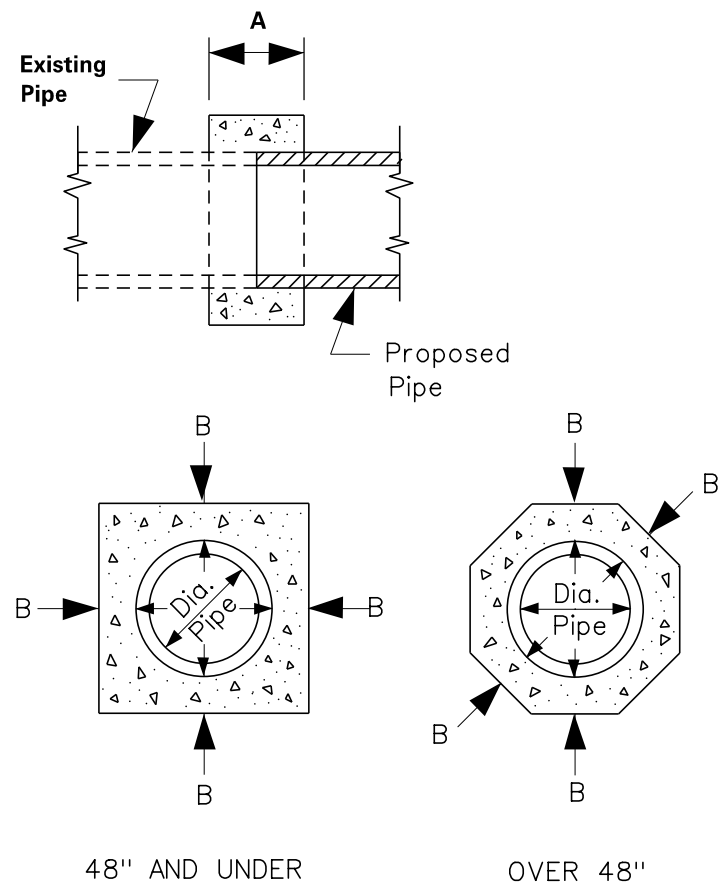

CONCRETE COLLAR DETAIL

DIAMETER OF PIPE	A	B	CU. YD. CONC. *	DIAMETER OF PIPE	A	B	CU. YD. CONC. *
15"	1'-0"	0'-6"	0.18	48"	2'-0"	1'-0"	2.10
18"	1'-0"	0'-6"	0.21	54"	2'-6"	1'-0"	2.09
21"	1'-0"	0'-6"	0.24	60"	3'-0"	1'-6"	4.31
24"	1'-0"	0'-6"	0.27	72"	3'-0"	1'-6"	5.03
30"	1'-6"	0'-9"	0.75	84"	3'-0"	2'-0"	7.94
36"	1'-6"	0'-9"	0.92	96"	3'-0"	2'-0"	8.90
42"	2'-0"	1'-0"	1.84	108"	3'-0"	2'-0"	9.87

* FOR INFORMATION ONLY

NOTES :

A AND B ARE MINIMUM DIMENSIONS. FORMING WILL NOT BE REQUIRED IF MINIMUM DIMENSIONS ARE OBTAINED. EXISTING METAL PIPES SHALL BE CAREFULLY INSPECTED AND APPROVED BY THE ENGINEER BEFORE EXTENDING THE PIPE. IF THE EXISTING PIPE IS IN POOR CONDITION, IT SHALL BE REPAIRED OR REPLACED. METAL CONNECTING BANDS SHALL NOT BE SUBSTITUTED FOR A CONCRETE COLLAR AS THEY DO NOT MEET THE STANDARD SPECIFICATION 604.6 REQUIREMENT FOR A LEAK RESISTANT SEAL.

CONCRETE FOR CONSTRUCTING THE COLLAR SHALL BE IN ACCORDANCE WITH SECTION 715.12 OF THE SPECIFICATIONS; HOWEVER, TESTING WILL NOT BE REQUIRED. THE COST OF CONCRETE COLLAR IS TO BE INCLUDED IN THE UNIT BID PRICE OF PROPOSED PIPE.

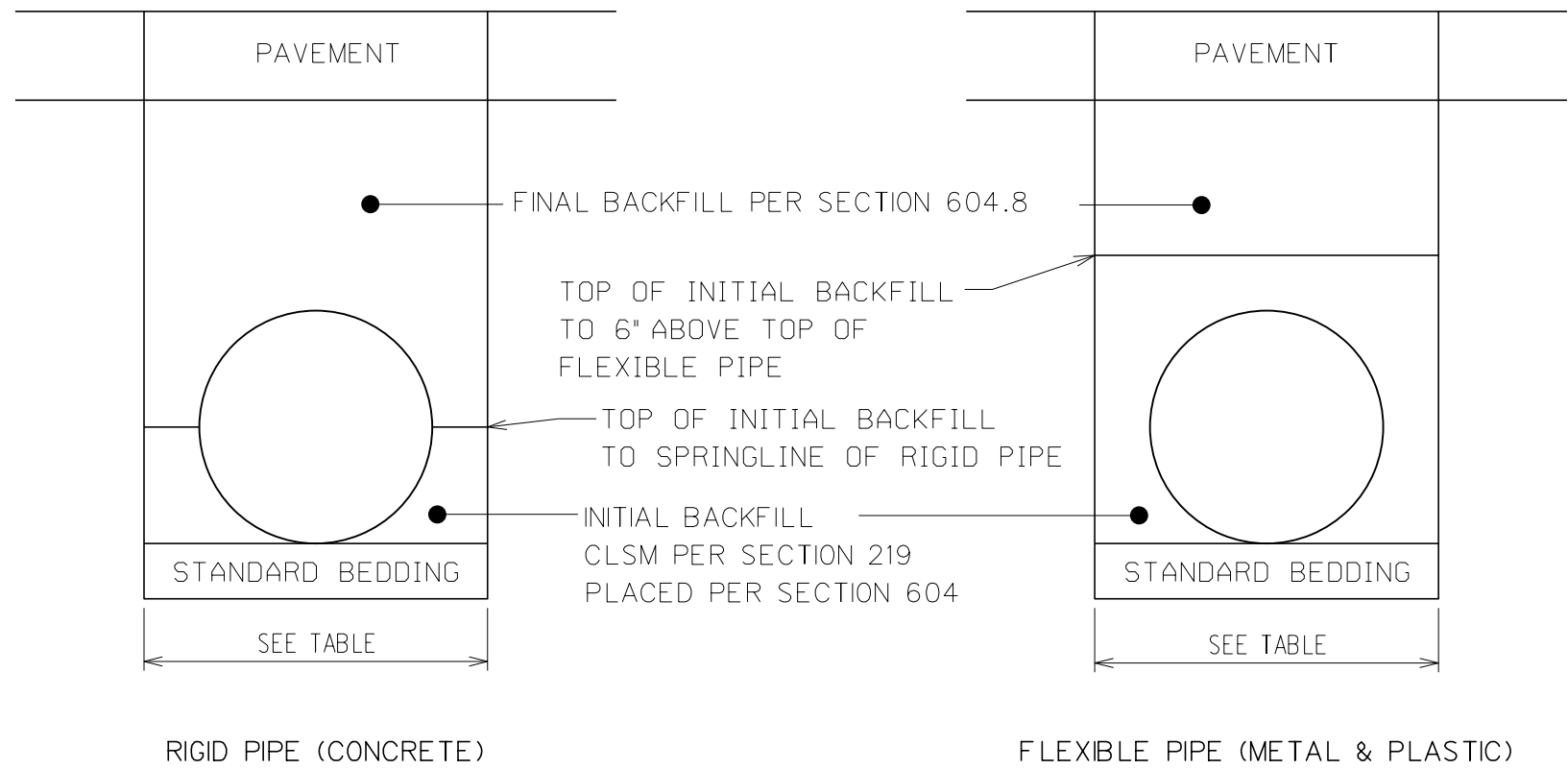

TYPE F DRAINAGE PIPE TRENCH

MINIMUM TRENCH WIDTH (IN)

DIAMETER OF PIPE	FOR RIGID PIPE	FOR FLEX. PIPE	DIAMETER OF PIPE	FOR RIGID PIPE	FOR FLEX. PIPE
12"	30"	30"	48"	74"	74"
15"	33"	33"	54"	82"	82"
18"	36"	36"	60"	90"	90"
24"	42"	42"	72"	106"	--
30"	51"	51"	84"	122"	--
36"	59"	59"	96"	139"	--
42"	66"	66"	108"	154"	--

TRENCH WIDTH MAY BE REDUCED TO OUTSIDE PIPE DIAMETER PLUS 12" FOR TRENCHES IN ROCK.

NOTES

CLSM - CONTROLLED LOW STRENGTH MATERIAL, SECTION 219

THIS DETAIL SHALL BE USED ON PROPOSED PIPES / CULVERTS WHEN SPECIFIED ON THE PLANS. THE COST OF THE TYPE F TRENCH IS INCIDENTAL TO THE PIPE/CULVERT.

FINAL TRENCH BACKFILL MAY BE COMPLETED WITH CLSM. CLASS B CONCRETE MAY BE SUBSTITUTED FOR CLSM.

LOW STRENGTH CLSM IS NOT A SUITABLE DRIVING SURFACE.

WEST VIRGINIA DEPARTMENT OF TRANSPORTATION
DIVISION OF HIGHWAYS
STANDARD DETAIL

PREPARED	1/7/11
REVISION DATE	
	10/10/13
	4/22/15
	10/3/18
	8/6/20

DRAINAGE PIPE
TRENCH,
CONCRETE COLLAR

STANDARD DETAIL SHEET DR-10

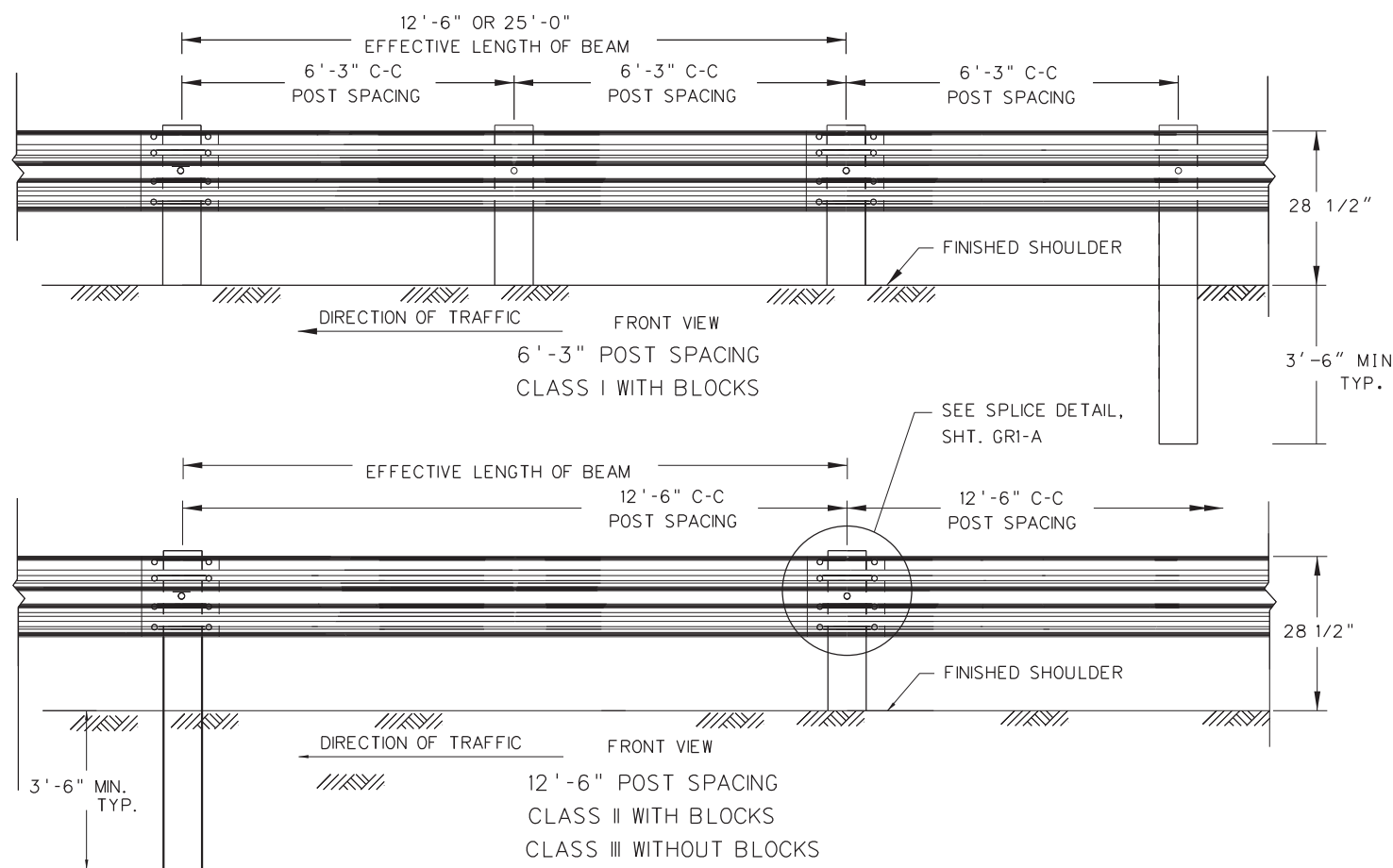

28-1/2" HEIGHT GUARDRAIL

Splice locations for 28 1/2" Guardrail shall be on the post.

GUARDRAIL HEIGHT

Transitions in guardrail height shall be accomplished at a rate of 1" vertical distance in 12.5' (one element) of horizontal distance. Height transitions shall end before end treatments or connections begin.

Height transitions between 28 1/2" and 31" require moving the splice on/off the post by placing one additional post at half the normal spacing.

Guardrail height shall be as indicated on plans.

Construction tolerances for rail height is plus/minus 1".

The Standard Trailing End Treatment is acceptable for both 28 1/2" and 31" guardrail height.

Approach Terminals-Separate approved product lists will be maintained for both 28 1/2" & 31" terminal height.

Guardrail that ties to Cut Slope Terminals (CST) must be transitioned per the standard details down to 28 1/2" height (the height of the CST).

Thrie Beam transitions shall be per Standard GR-11 dated 11-13-12 for 28 1/2" and dated 11-21-12 for 31".

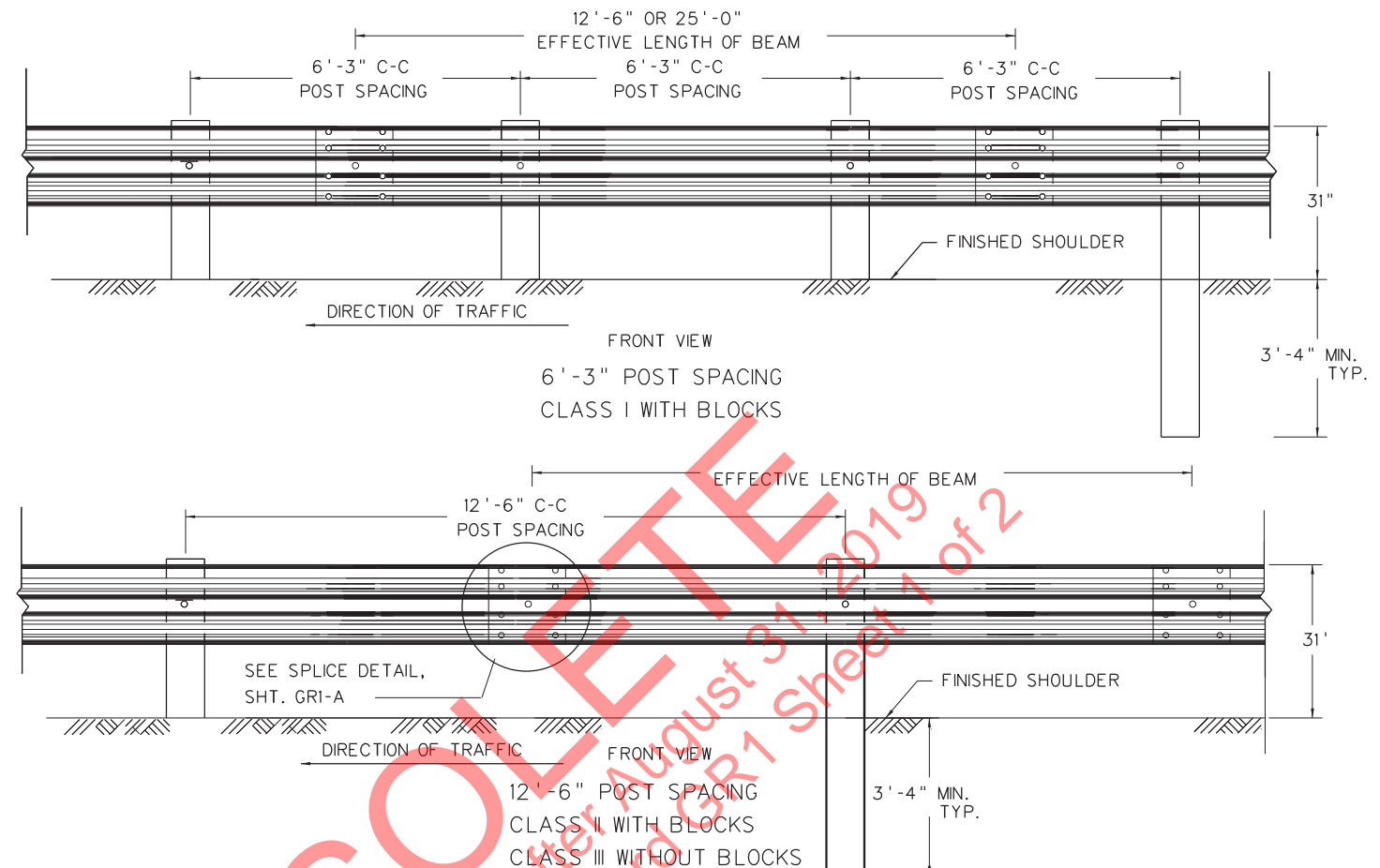

31" HEIGHT GUARDRAIL

Splice location for 31" Guardrail are generally off the post. However, for tight post spacings, splices on the posts are necessary and acceptable.

NOTES

Guardrail systems on NHS routes must meet NCHRP 350 or the most current AASHTO Manual for Assessing Safety Hardware (MASH) crash testing criteria and have an eligibility letter to be used on WVDOH projects.

Guardrail shall be secured to the blocks, post and other elements by 5/8" dia. bolts and nuts conforming to the details herein and to the requirements of 712.4 of the Standard Specifications. Nuts shall conform to ASTM A563, Grade A or better.

Approach and Trailing End Treatments shall be as shown or specified on the Plans or directed by the Engineer.

The pay quantity of guardrail will be the Linear Feet of guardrail measured along the face of the rail from center to center of end posts. Cost of the Terminal Section Buffer End shall be included in the cost of the Guardrail.

The approach slope to the face of all guardrail shall be 10:1 or flatter. The Type, Class and Height of Guardrail shall be as shown in the Plans.

Lap Guardrail in Direction of Traffic.

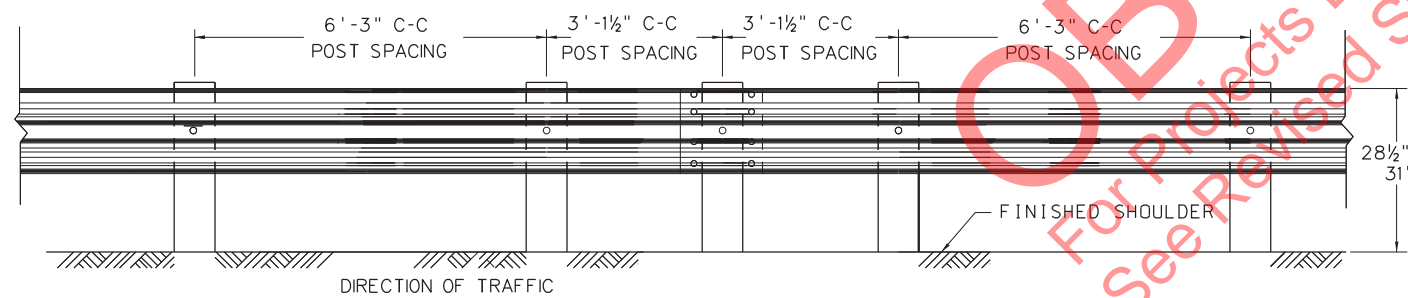

FRONT VIEW
3'-1 1/2" POST SPACING
CLASS IV WITHOUT BLOCKS
CLASS V WITH BLOCKS

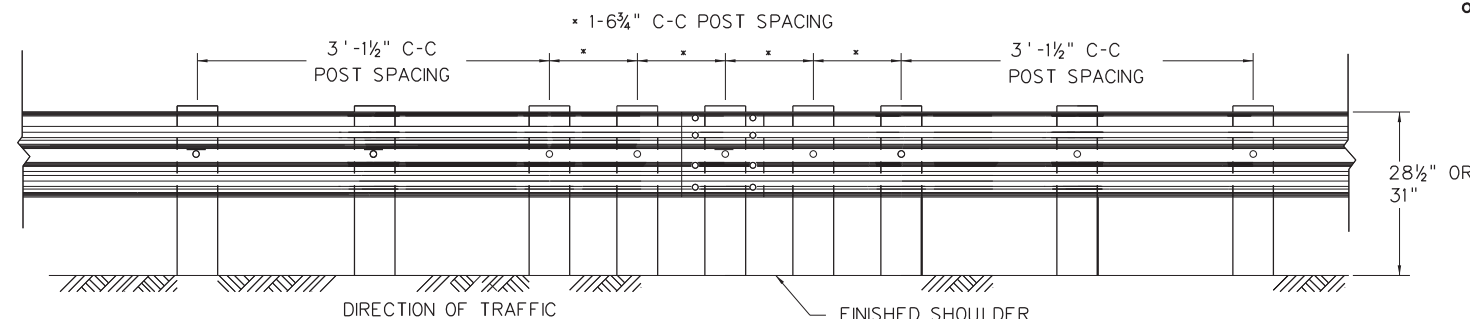

FRONT VIEW
1'-6 3/4" POST SPACING

WEST VIRGINIA DEPARTMENT OF TRANSPORTATION
DIVISION OF HIGHWAYS
STANDARD DETAIL

PREPARED	7-1-99
REVISION DATE	
	11-13-12

GUARDRAIL ELEMENTS
(SHEET 1 OF 2)

STANDARD SHEET GR1

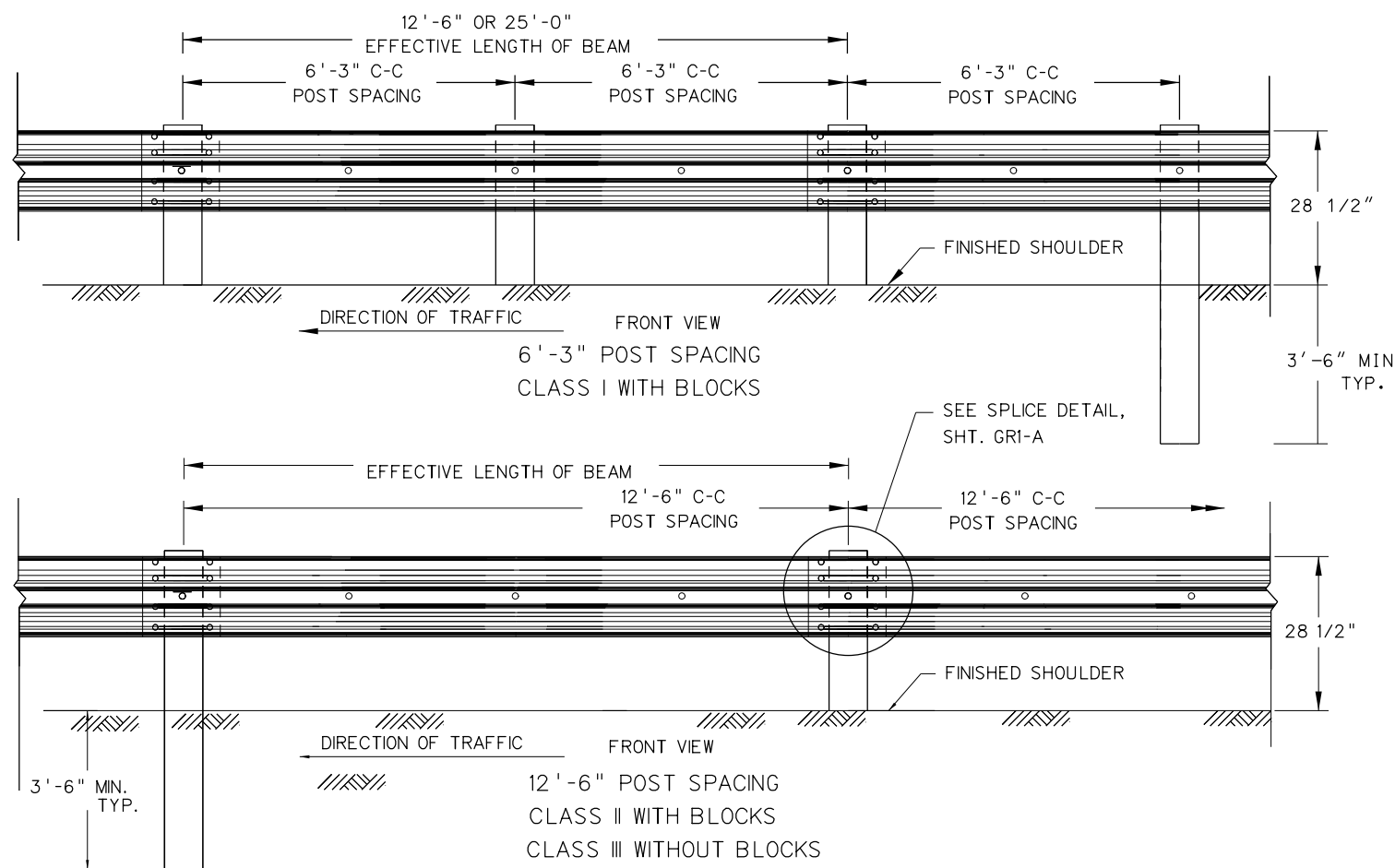

28-1/2" HEIGHT GUARDRAIL

Splice locations for 28 1/2" Guardrail shall be on the post.

GUARDRAIL HEIGHT

Transitions in guardrail height shall be accomplished at a rate of 1" vertical distance in 12.5' (one element) of horizontal distance. Height transitions shall end before end treatments or connections begin.

Height transitions between 28 1/2" and 31" require moving the splice on/off the post by placing one additional post at half the normal spacing.

Guardrail height shall be as indicated on plans.

Construction tolerances for rail height is plus/minus 1".

The Special Trailing End Treatment is acceptable for both 28 1/2" and 31" guardrail height.

Approach Terminals-Separate approved product lists will be maintained for both 28 1/2" & 31" terminal height.

31" Guardrail that ties to a Cut Slope Terminal (CST) must be transitioned down to 28 1/2" height (the height of the CST) per the above paragraph.

Three Beam transitions shall be per Standard GR-11 dated 11-13-12 for 28 1/2" and dated 11-2-15 for 31".

Factory punched slots at 3' 1-1/2" spacing are acceptable for all classes of guardrail.

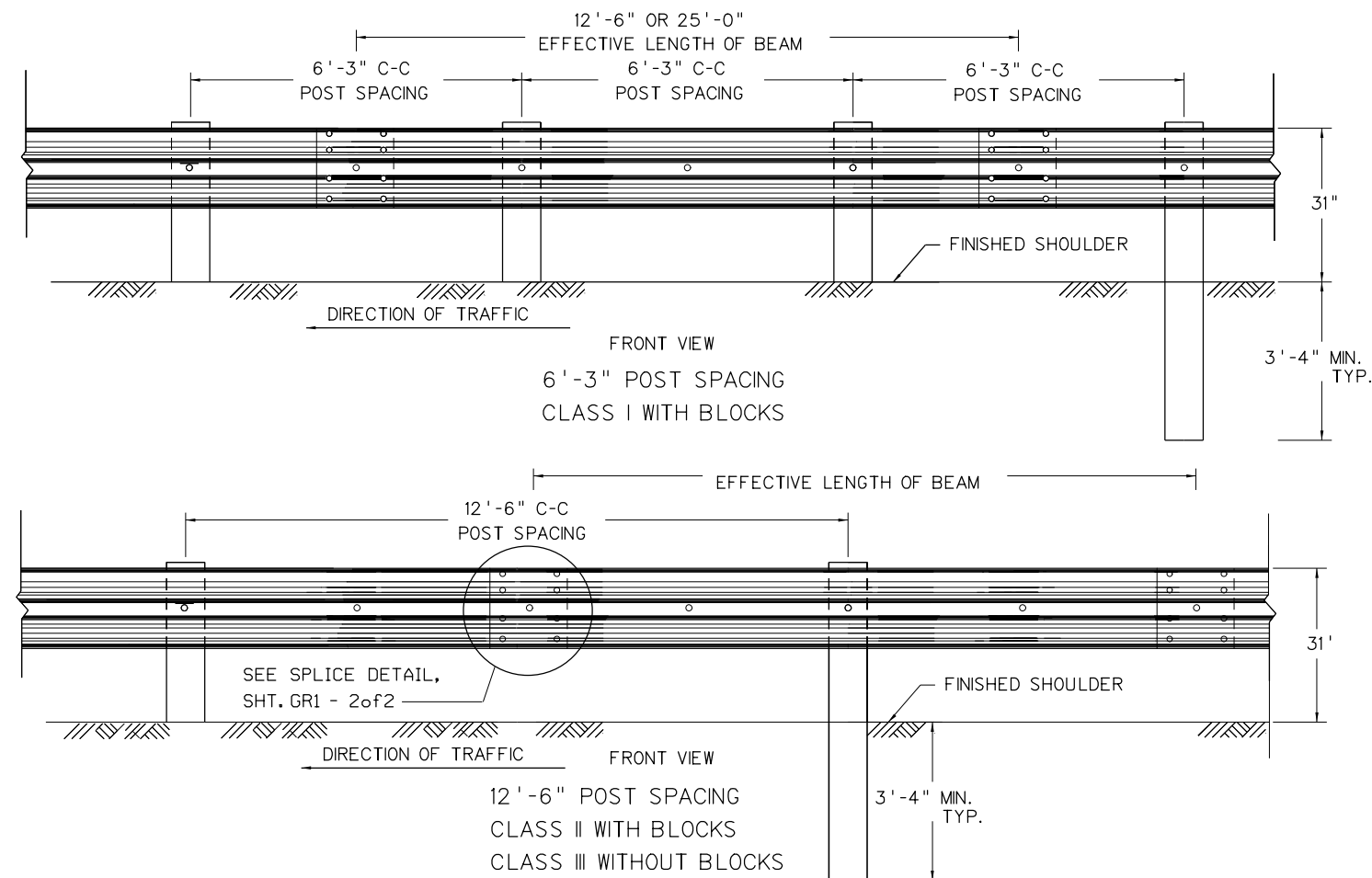

31" HEIGHT GUARDRAIL

Splice location for 31" Guardrail are generally off the post. However, for tight post spacings, splices on the posts are necessary and acceptable.

NOTES

Guardrail systems on NHS routes must meet NCHRP 350 or the most current AASHTO Manual for Assessing Safety Hardware (MASH) crash testing criteria and have an eligibility letter to be used on WVDOT projects.

Guardrail shall be secured to the blocks, post and other elements by 5/8" dia. bolts and nuts conforming to the details on Sht. GR1 2of2 and to the requirements of 712.4 of the Standard Specifications. Nuts shall conform to ASTM A563, Grade A or better.

Approach and Trailing End Treatments shall be as specified on the Plans or directed by the Engineer. shown or

The pay quantity of guardrail will be the Linear Feet of guardrail measured along the face of the rail from center to center of end posts. Cost of the Terminal Section Buffer End (if any) shall be included in the cost of the guardrail.

The approach slope to the face of all guardrail shall be 10:1 or flatter.

The Type, Class and Height of Guardrail shall be as shown in the Plans.

Lap Guardrail in Direction of Traffic.

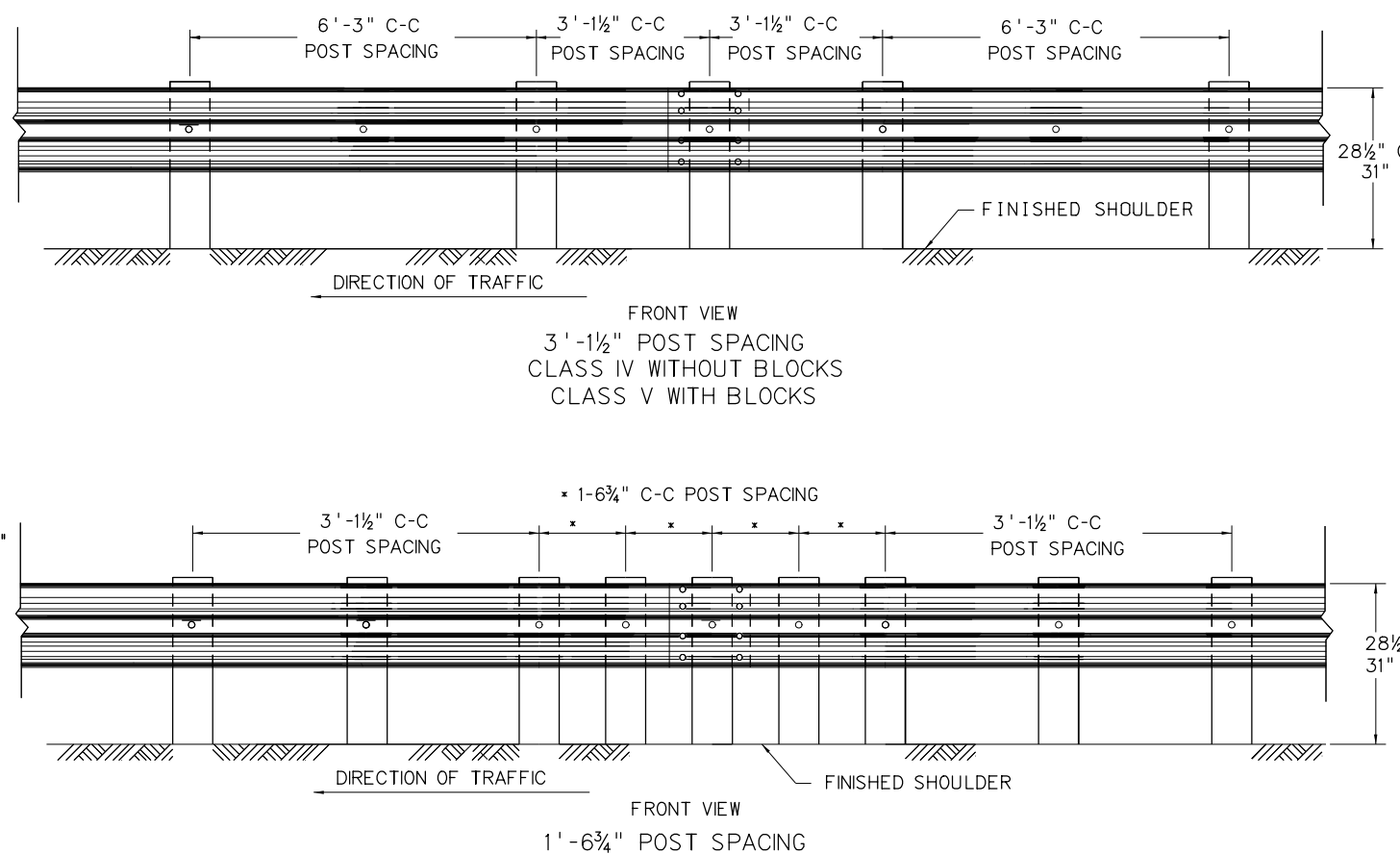

WEST VIRGINIA DEPARTMENT OF TRANSPORTATION
DIVISION OF HIGHWAYS
STANDARD DETAIL

PREPARED	7-1-99
REVISION DATE	11-13-12
	05-30-18

GUARDRAIL ELEMENTS
(SHEET 1 OF 2)

STANDARD SHEET GR1

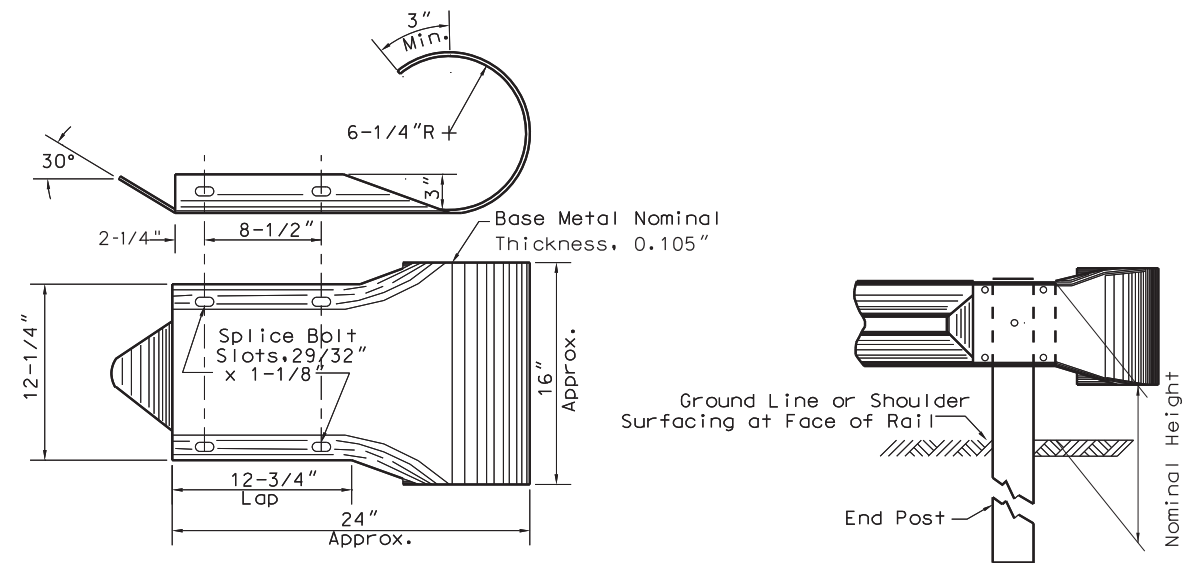
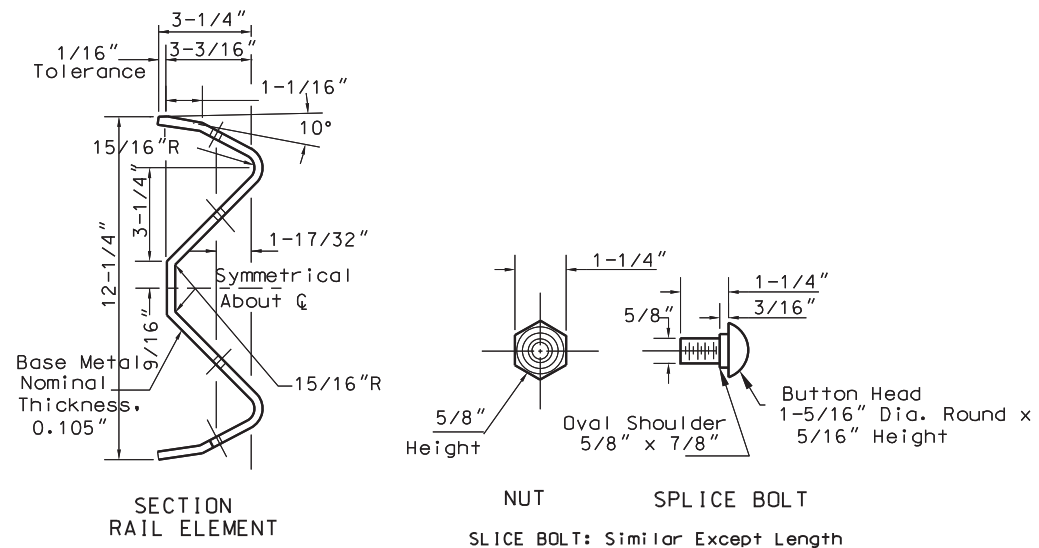

TERMINAL SECTION BUFFER END

(For Use Only on Unanchored Ends And on Special Trailing End Terminal)

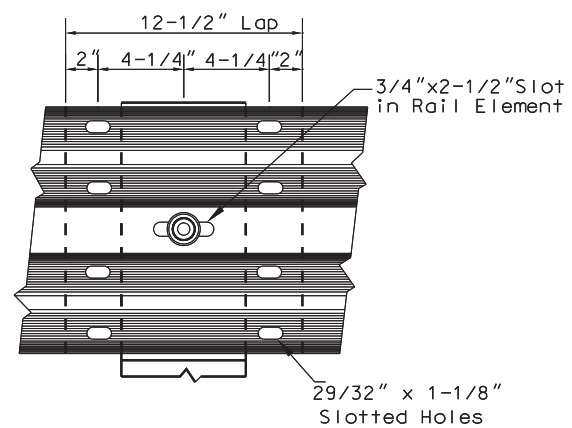

RAIL SPLICE - 28 1/2" HEIGHT ON POST

Eight (8) Splice Bolts are to be used at all Rail Splices

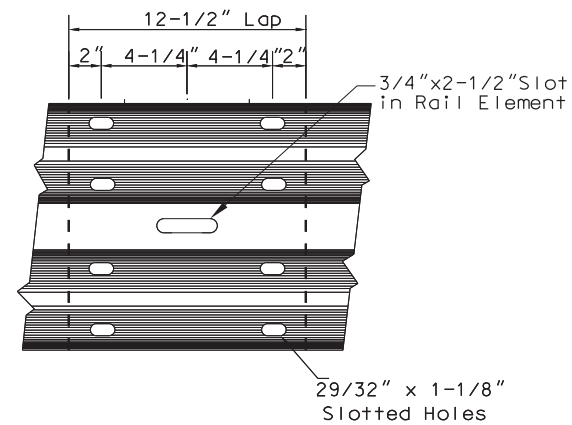

RAIL SPLICE - 31" HEIGHT OFF POST

Eight (8) Splice Bolts are to be used at all Rail Splices

WEST VIRGINIA DEPARTMENT OF TRANSPORTATION
DIVISION OF HIGHWAYS
STANDARD DETAIL

PREPARED 11-13-12
REVISION DATE

GUARDRAIL ELEMENTS
(SHEET 2 OF 2)

STANDARD SHEET GR1

NOTES

GENERAL:

Guardrail systems on NHS routes must meet current NCHRP 350 or the most current AASHTO Manual for Assessing Safety Hardware (MASH) crash testing criteria and have an FHWA eligibility letter to be used on WVDOT projects.

Only FHWA approved guardrail systems utilizing wood or approved alternate block-outs shown on the Division's "Approved Source/Product Listing" shall be used. Steel "W" shapes shall not be used for block-outs. Only one type of block shall be used for block-outs throughout any project, unless otherwise specified.

"Blocks for block-outs" shall be used on all posts except when otherwise noted on plans. When blocks are not provided, the post details will be as shown herein, except the 5/8" bolt minimum length will be reduced as required, the 1" minimum notch for the wood guardrail post (round) will not be used, and nails for block stability will not be used. For steel posts without blocks, details of the posts shall conform to the "Steel Guardrail Post (Wood Block)" details herein, with the additional holes (to facilitate erection) being optional.

The circular washers shall be made of steel and galvanized in accordance with the requirements of AASHTO M232.

WOOD POSTS:

Posts and blocks shall be the same type of wood. Wood posts shall be pressure-treated after notching, in accordance with Section 710.5 of the specifications.

*** The 1" (minimum) notch dimension as shown for round wooden posts shall be located along the vertical centerline for the entire upper 14" of the post and shall apply regardless of whether the post is notched (as shown) or otherwise cut or sawed to form a vertical flat plane and then, at some location below the top 14", is angularly sliced out to the surface of the post. Post length will be 6' - 1/2" unless otherwise noted.**

STEEL POSTS:

Blocks shall be centered on their posts and the center of the block holes, for bolts connecting rails to blocks, shall be horizontally offset 1-1/8" from the center of the steel posts toward the post edge facing approaching traffic for both polymer and wood blocks, as shown for wood blocks on the Plan view of the Block Stop Detail. Post length will be 6' - 1/2" unless otherwise noted.

WOOD BLOCKS:

The type (species) of wood for blocks is to be one of the types (species) permitted by specifications for wood posts. Wood blocks shall be pressure-treated in conformance with the requirements for wood posts. However, creosote oil is not permitted as a preservative in the pressure treatment of wood blocks to be erected on steel posts. 8" x 6" wood blocks shall be positioned so that the 6" x 14" faces of the blocks are the contact faces for the rail elements and the posts in order to achieve the blockout dimension shown. When wood block is used adjacent to a wood post, the block shall be nailed to the post with a galvanized steel 10d common nail. The nail is to be driven into the center of the top or bottom of the block.

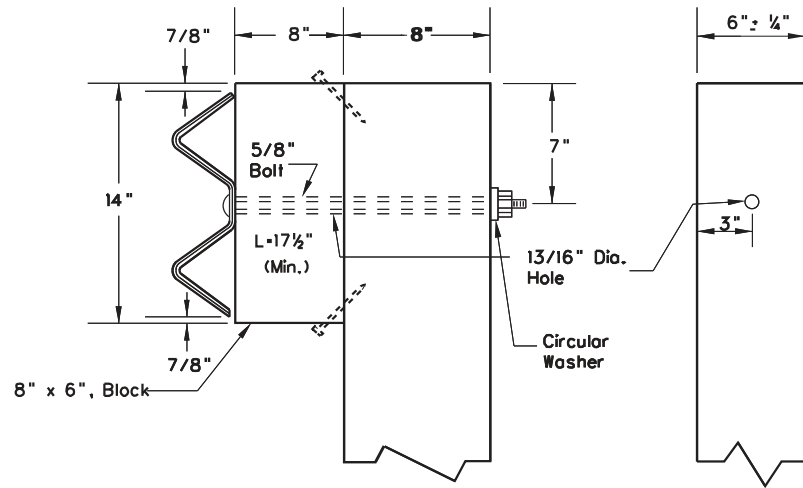

WOOD GUARDRAIL POST (RECTANGULAR)

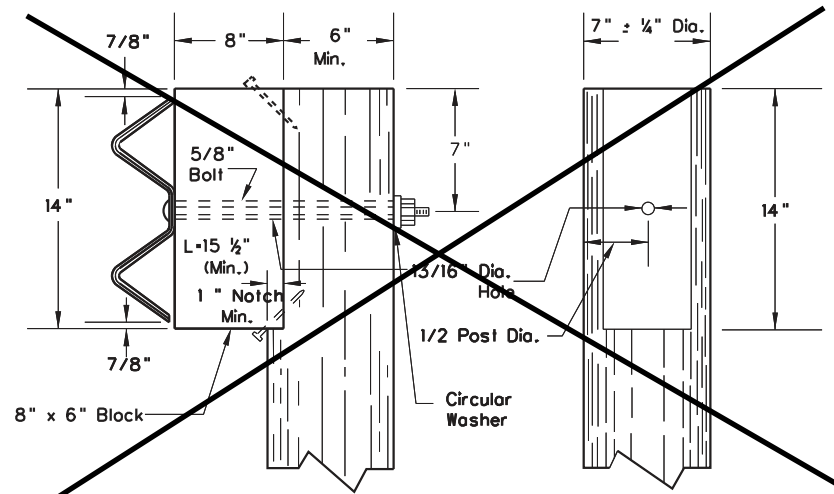

~~WOOD GUARDRAIL POST (ROUND)~~

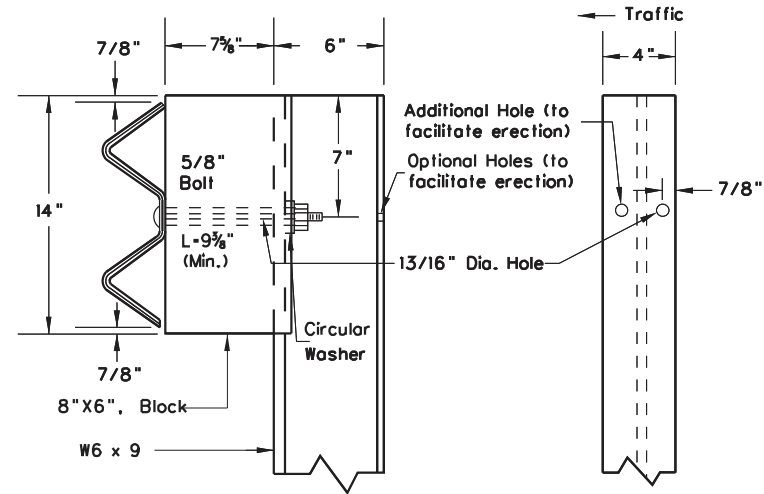

STEEL GUARDRAIL POST (WOOD BLOCK)

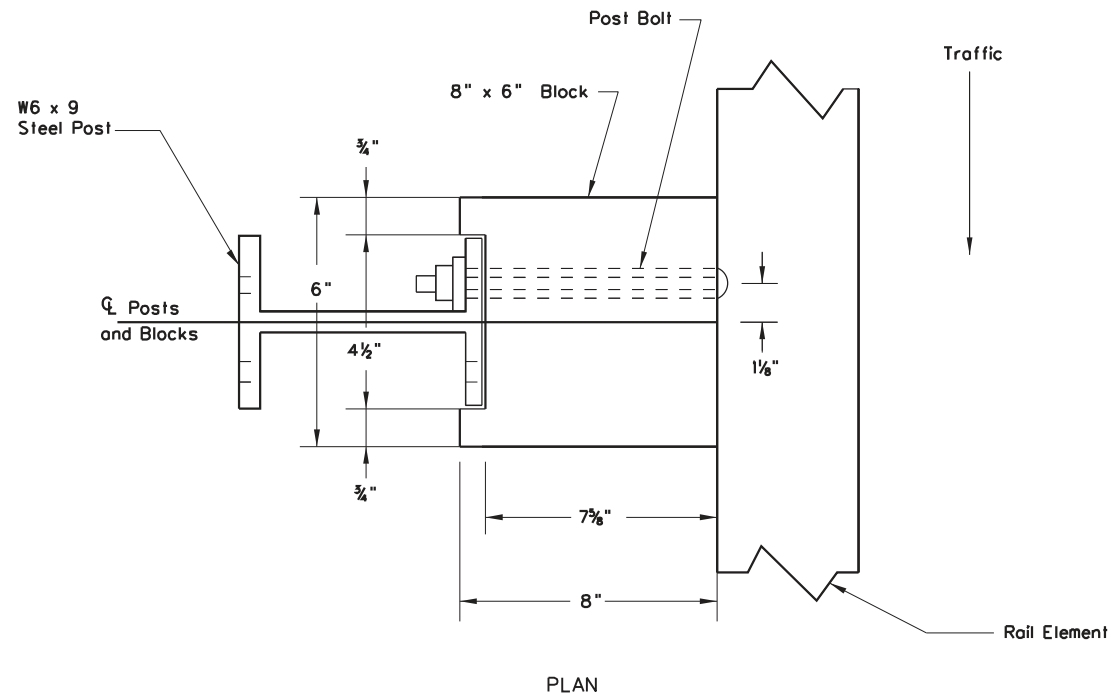

PLAN

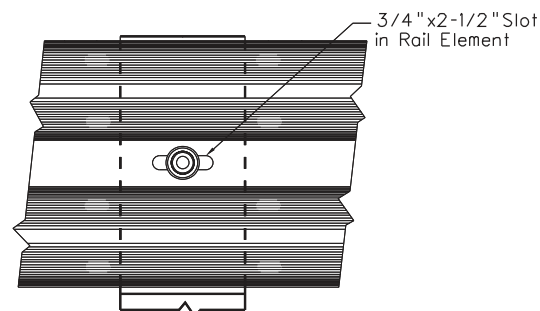

WOOD POST DETAIL

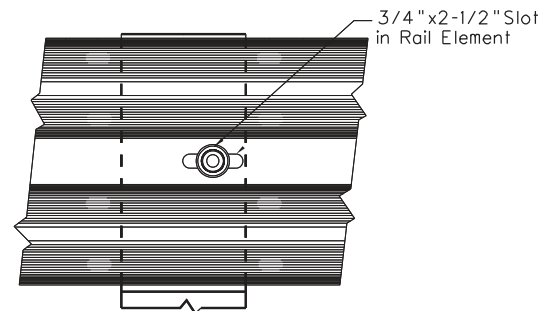

STEEL POST DETAIL

*** Round Wood Posts shall not be used on WVDOT Projects let after 12-31-2017.**

WEST VIRGINIA DEPARTMENT OF TRANSPORTATION DIVISION OF HIGHWAYS STANDARD DETAIL	
REVISED STANDARD DETAIL	
GUARDRAIL POSTS AND BLOCKS	
PREPARED / 7-1-99	
REVISION DATE	
03-05-2010	
06-16-2010	
11-13-12	
* 12-18-2017	
STANDARD SHEET GR2	

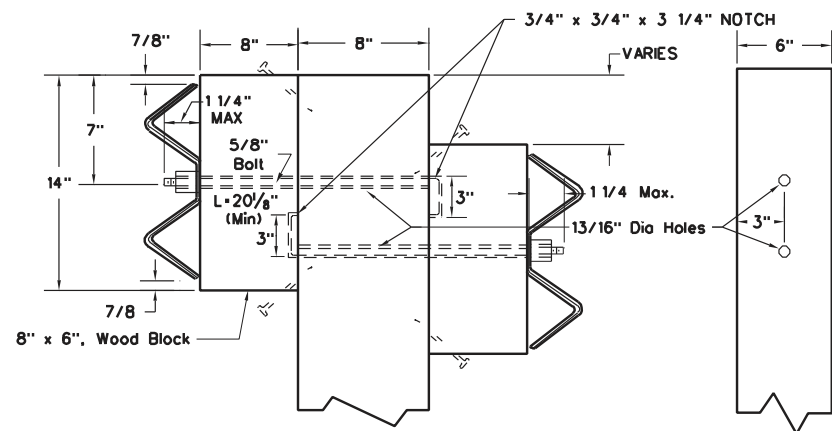

WOOD GUARDRAIL POST (RECTANGULAR)
(BEAMS AT DIFFERENT ELEVATIONS)

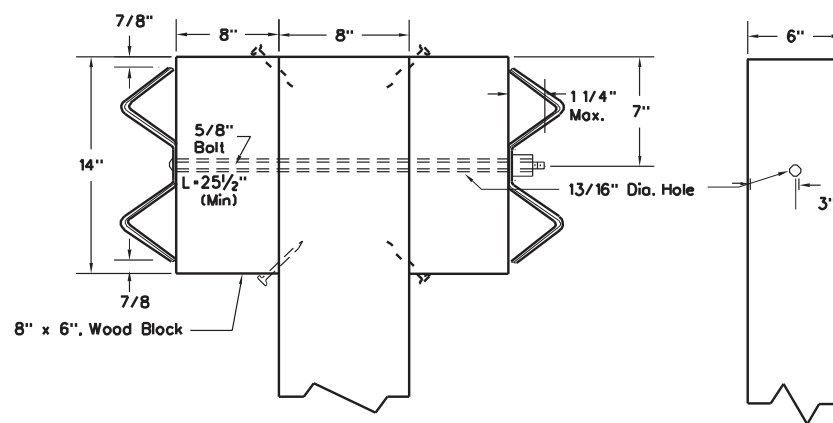

WOOD GUARDRAIL POST (RECTANGULAR)
(BEAMS AT SAME ELEVATION)

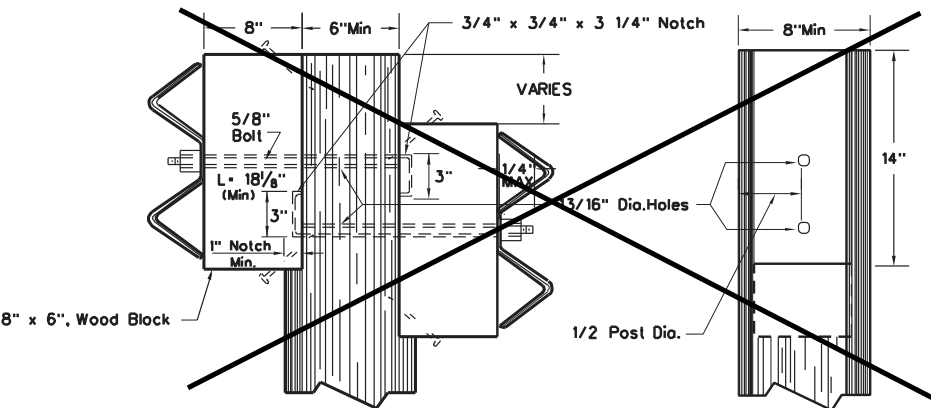

~~WOOD GUARDRAIL POST (ROUND)
(BEAMS AT DIFFERENT ELEVATIONS)~~

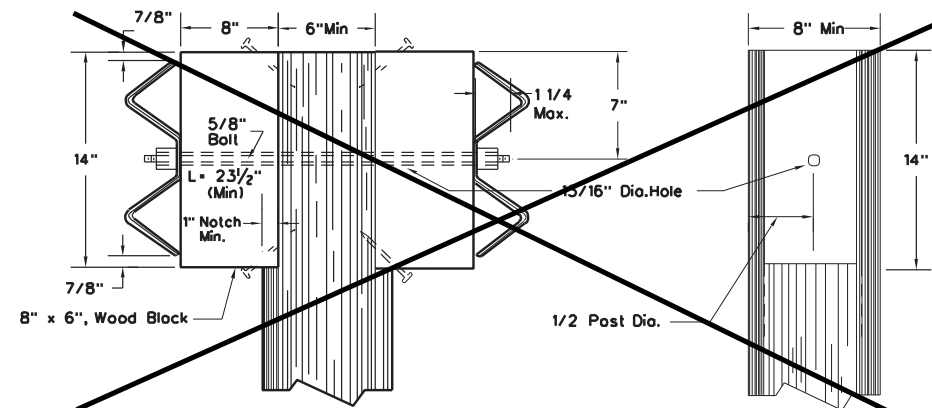

~~WOOD GUARDRAIL POST (ROUND)
(BEAMS AT SAME ELEVATION)~~

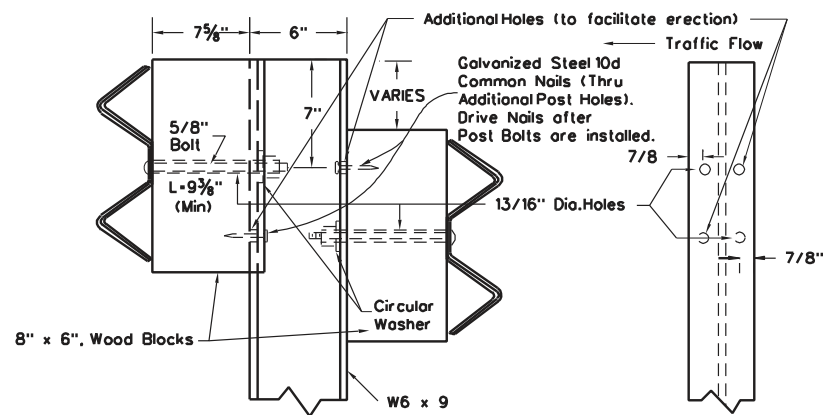

STEEL GUARDRAIL POST (WOOD BLOCK)
(BEAMS AT DIFFERENT ELEVATIONS)

NOTES

The blocks shall be bolted to the steel posts in the same manner when the beams are at the same elevation as they would when the beams are at different elevations.

The standard bolt shall be used for wood guardrail post when possible.

The applicable details and notes of Standard Sheet GR2 shall apply to this sheet.

* ~~The 1" (minimum) notch dimension as shown for round wooden posts shall be located along the vertical centerline for the entire upper 14" of the post and shall apply regardless of whether the post is notched (as shown) or otherwise cut or sawed to form a vertical flat plane and then, at some location below the top 14", is angularly sliced out to the surface of the post.~~

When a wood block is used adjacent to a wood post, the block shall be nailed to the post with a galvanized steel 10d common nail. The nail is to be driven in the center of the top or bottom of the block.

* Round Wood Posts shall not be used on WVDOH Projects let after 12-31-2017.

WEST VIRGINIA DEPARTMENT OF TRANSPORTATION
DIVISION OF HIGHWAYS
STANDARD DETAIL

REVISED STANDARD DETAIL

PREPARED 7-1-99

REVISION DATE
12-18-2017

DOUBLE-FACED
GUARDRAIL POSTS

STANDARD SHEET GR3

NOTES

- FOR FILL TO CUT GUARDRAIL TERMINALS (TRAILING END, TWO LANE HIGHWAYS, AND ALL APPROACH END) WHERE ANCHORED ENDS ARE SPECIFIED, THE DETAILS AND REQUIREMENT HEREIN SHALL BE APPLICABLE.
- PRIOR TO PLACING GUARDRAIL, A FINAL CHECK OF EXISTING CONDITIONS WILL BE MADE BY THE ENGINEER AND ANY ADJUSTMENT NECESSARY TO INSURE THE PROPER LOCATION AND FUNCTIONING OF THE GUARDRAIL FOR THE PURPOSE FOR WHICH IT IS INTENDED WILL BE MADE ACCORDINGLY.
- POSTS, BLOCKS AND RAIL ELEMENTS SHALL BE THE SAME TYPES USED IN THE NORMAL GUARDRAIL INSTALLATION, UNLESS OTHERWISE NOTED. GUARDRAIL BLOCKS SHALL NOT BE USED ON ANY POSTS COMPLETELY UNDERGROUND.
- THE FINAL DECISION AS TO THE TYPE OF CUT SLOPE TERMINAL INSTALLATION (TYPE A OR B) AT EACH LOCATION WILL BE BASED ON THE ACTUAL MATERIALS ENCOUNTERED DURING CONSTRUCTION.
- CUT SLOPE TERMINAL INSTALLATION CAN INTERFERE WITH NORMAL DRAINAGE THROUGH A CUT SECTION. WHEN THIS OCCURS, DETAILS FOR MAINTAINING POSITIVE DRAINAGE WILL BE SHOWN ON THE PROJECT PLANS.
- WHEN INSTALING CST TYING INTO 31" TOP OF RAIL HEIGHT GUARDRAIL, THE CST SHALL BE INSTALLED AT 28-1/2" HEIGHT. TAPER 31" GUARDRAIL DOWN VERTICALLY PRIOR TO CST INSTALLATION.
- THE CST GUARDRAIL TERMINAL SHOULD BE USED ONLY WITH 2:1 OR STEEPER BACK SLOPE.
- THE FLARE RATE OF THE GUARDRAIL MAY BE STEEPENED TO 8:1 AFTER CROSSING THE DITCH BOTTOM TO SHORTEN THE LENGTH OF THE TERMINAL.
- RUBRAIL TO EXTEND FROM POST 2, THROUGH ENTIRETY OF DITCH, TO POST 22 AT A MINIMUM.
- FOR THE RUB RAIL SECTION USE 8' LONG POSTS.
- SEE GR-4A AND GR-4B FOR DETAILS OF TYPE A AND TYPE B TERMINALS.
- MAXIMUM CLEARANCE FROM BOTTOM OF W-BEAM TO GROUND LINE WITHOUT W-BEAM RUBRAIL IS 18".

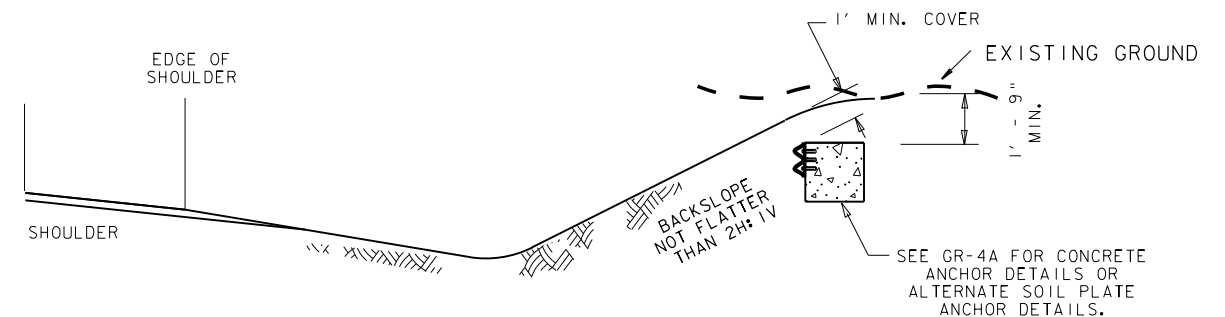
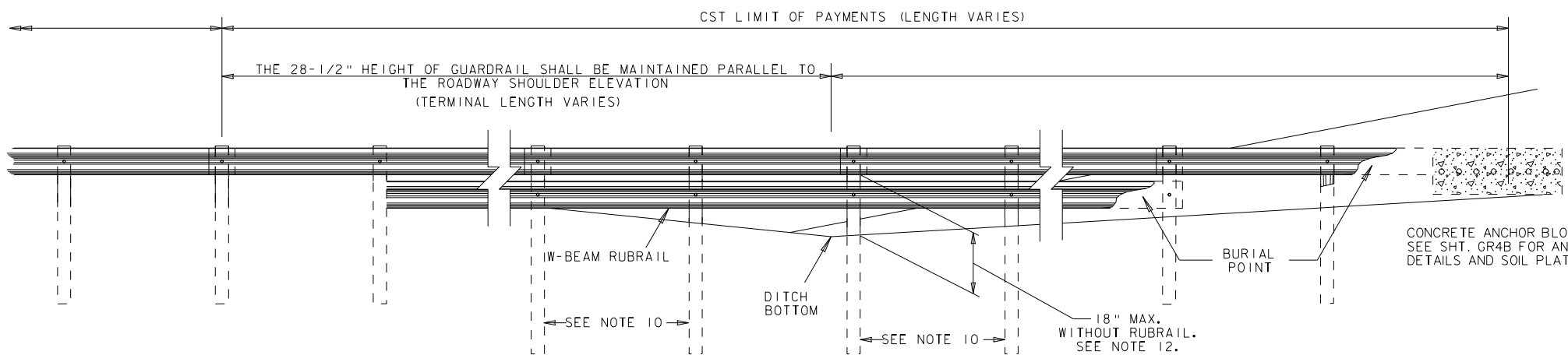
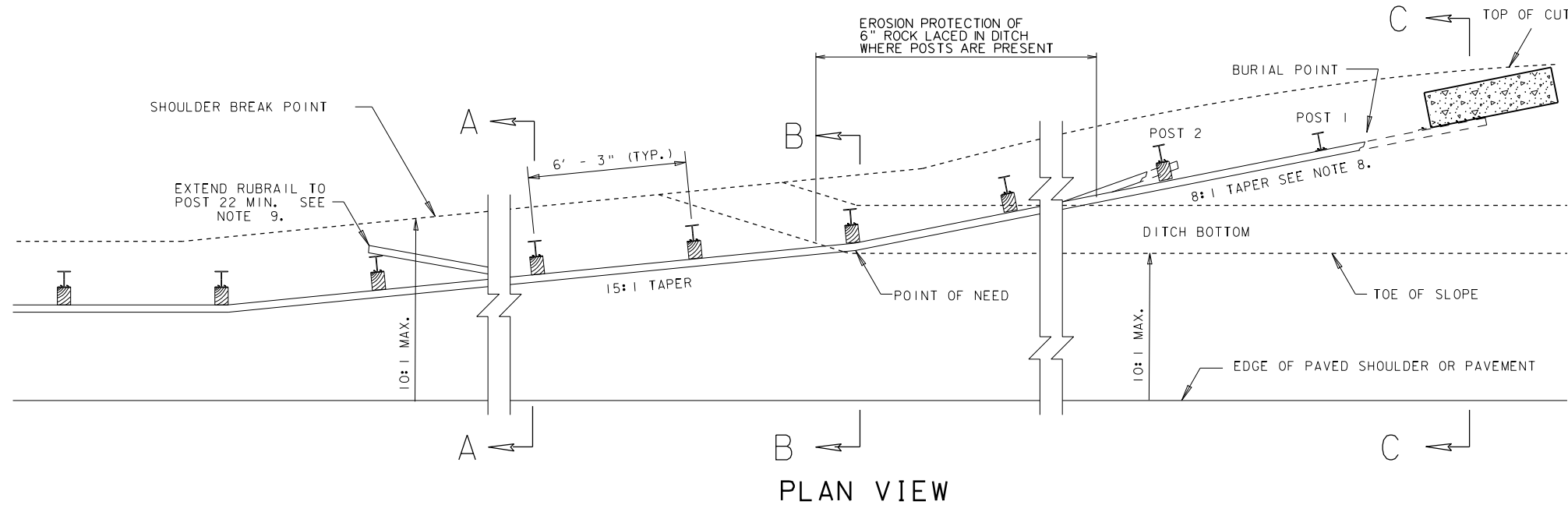

SECTION C-C

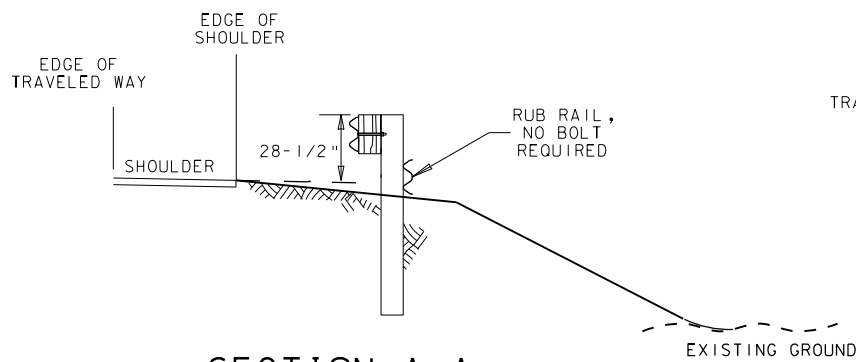

SECTION A-A

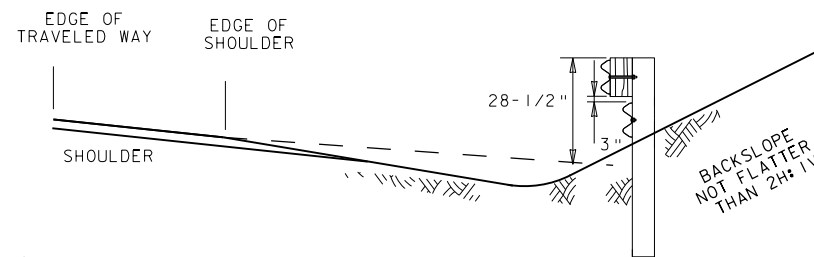

SECTION B-B

WEST VIRGINIA DEPARTMENT OF TRANSPORTATION
DIVISION OF HIGHWAYS
STANDARD DETAIL

PREPARED 7-1-99
REVISION DATE
4/22/15

CUT SLOPE TERMINAL

STANDARD SHEET GR4

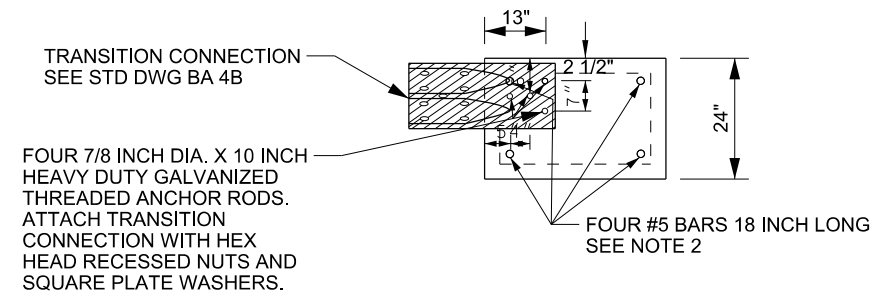
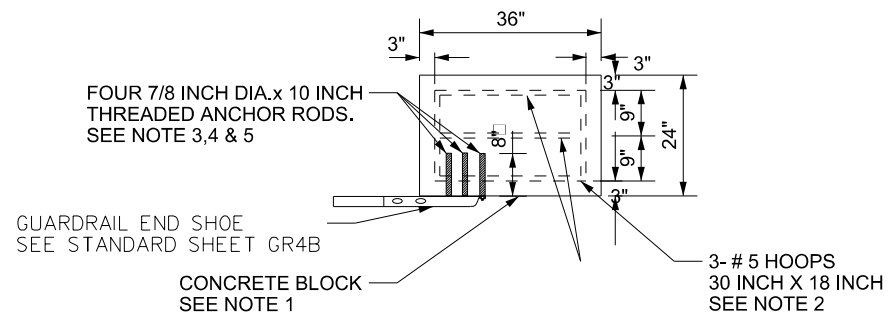

NOTES:

1. USE CLASS B CONCRETE.
2. USE EPOXY COATED REINFORCING STEEL, PER SECTION 602 OF THE SPECIFICATIONS.
3. USE GALVANIZED THREADED ROD.
4. THREADED RODS CAN BE CAST INTO CONCRETE BLOCK OR HOLES CAN BE DRILLED INTO BLOCK AND RODS ANCHORED WITH EPOXY.
5. DRILL HOLES A MINIMUM 9 INCH DEEP. CLEAN DRILLED HOLES PRIOR TO INSERTING THREADED ROD.

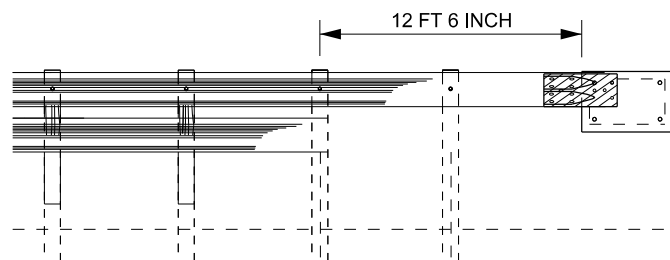

**RUBRAIL ELEMENT
OPTION I
CONCRETE BLOCK**

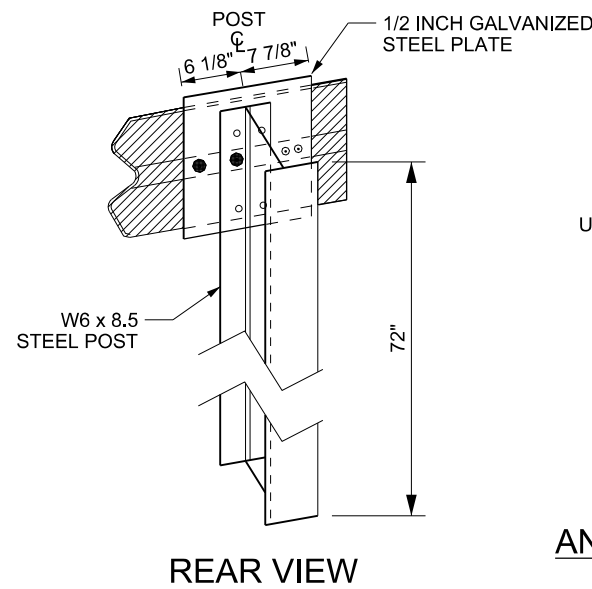

**ANCHOR POST/PLATE ATTACHMENT
FOR SINGLE RAIL ELEMENT**

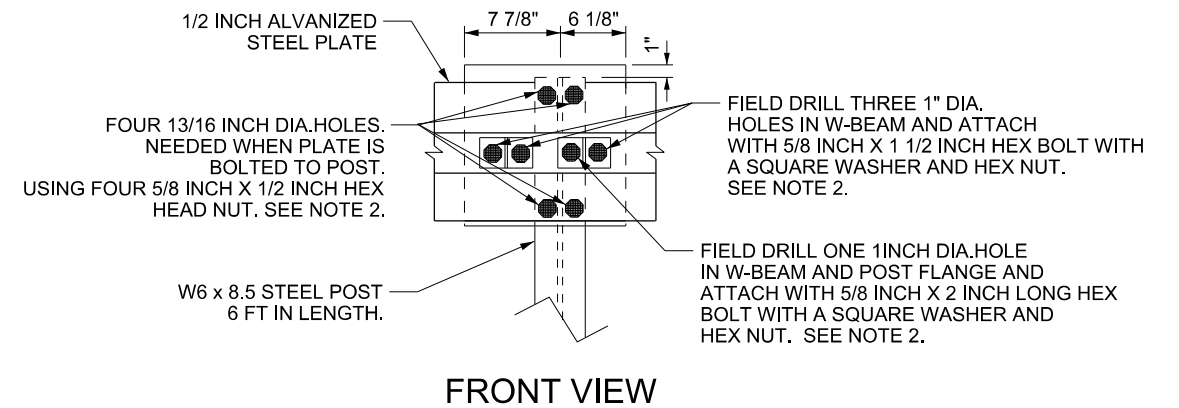

FRONT VIEW

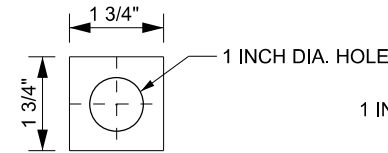

**SQUARE WASHER
(3/16 INCH THICK, GALVANIZED)**

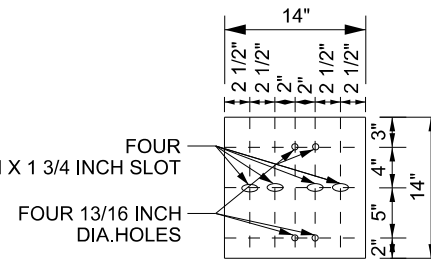

**1/2 INCH STEEL PLATE
(GALVANIZED)**

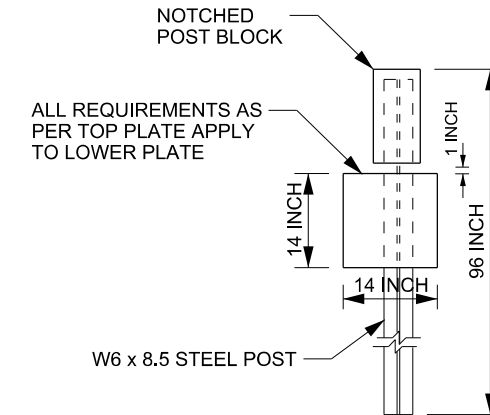

**ANCHOR POST/PLATE ATTACHMENT
FOR RUB RAIL ELEMENT**

NOTES:

1. USE 1/2 INCH STEEL PLATE MEETING REQUIREMENTS OF ASTM A 36.
2. GALVANIZING REQUIRED FOR PLATE AND HARDWARE.
3. USE ZINC RICH PAINT TO COAT FIELD DRILLED HOLES.

GENERAL NOTES:

TYPE A (SOFT SHALE OR SOIL) CUT SLOPE TERMINAL GUARDRAIL SHALL BE THAT GUARDRAIL WHICH IS TO EXTEND A MINIMUM OF TWO 6'-3" SPANS INTO THE CUT SLOPE, FROM THE FIRST POST BEYOND THE TOE OF THE CUT SLOPE AND IS TO TERMINATE A MINIMUM OF 1'-0" BELOW THE GROUND ELEVATION OF THE BACK SLOPE, EXCEPT IN AREAS OF HEAVY ROCK OUTCROPPING WHERE THE MINIMUM DEPTH MAY BE 6 INCHES.

A TRENCH NO GREATER THAN 18" IN WIDTH SHALL BE EXCAVATED INTO THE CUT SLOPE TO ACCOMMODATE THE TYPE A TERMINAL INSTALLATION. THE CONTRACTOR SHALL ARRANGE HIS WORK SEQUENCE SUCH THAT EACH TYPE A CUT SLOPE TERMINAL INSTALLATION BE EXCAVATED, POSTS DRIVEN, RAIL ELEMENTS AND GUARDRAIL COMPONENTS ASSEMBLED, TRENCH BACKFILLED, AND DISTURBED SLOPE SHAPED SEEDED AND MULCHED ALL IN A CONTINUOUS OPERATION.

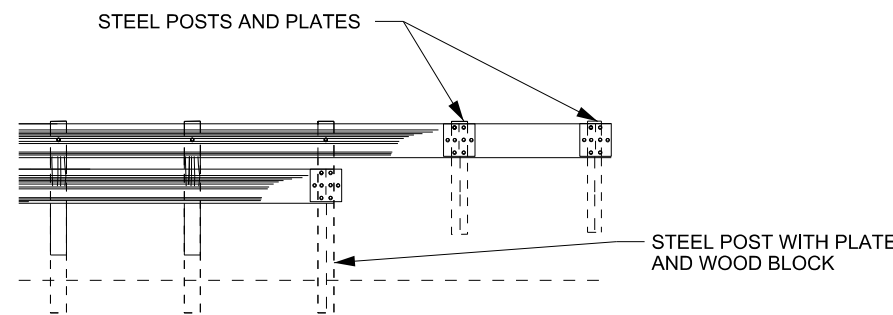

**RUBRAIL ELEMENT
OPTION II
STEEL POSTS AND PLATES**

WEST VIRGINIA DEPARTMENT OF TRANSPORTATION
DIVISION OF HIGHWAYS
STANDARD DETAIL

PREPARED 4/22/15
REVISION DATE

**CUT SLOPE TERMINAL
TYPE A INSTALLATION
SOFT SHALE OR SOIL**

STANDARD SHEET GR4A

Type B (Shale or Rock) Cut Slope Terminal installation shall consist of anchoring the guardrail against the face of the cut slope utilizing guardrail end shoes and rock bolts, as detailed herein.

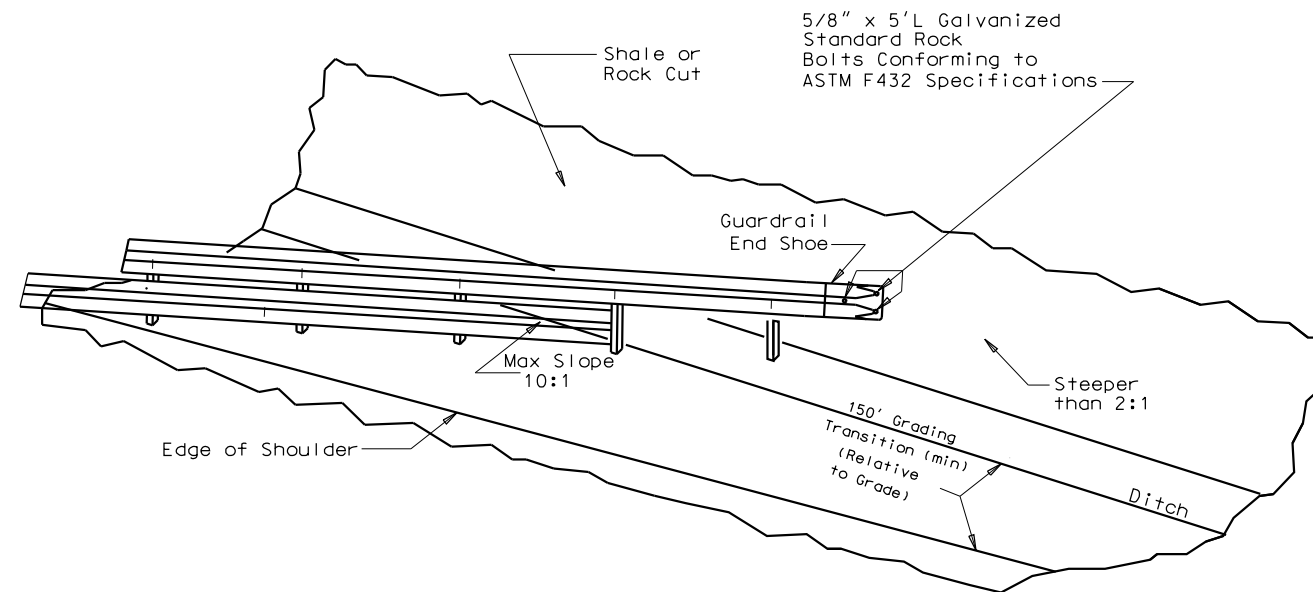

TYPE B (SHALE OR ROCK) CUT SLOPE TERMINAL INSTALLATION

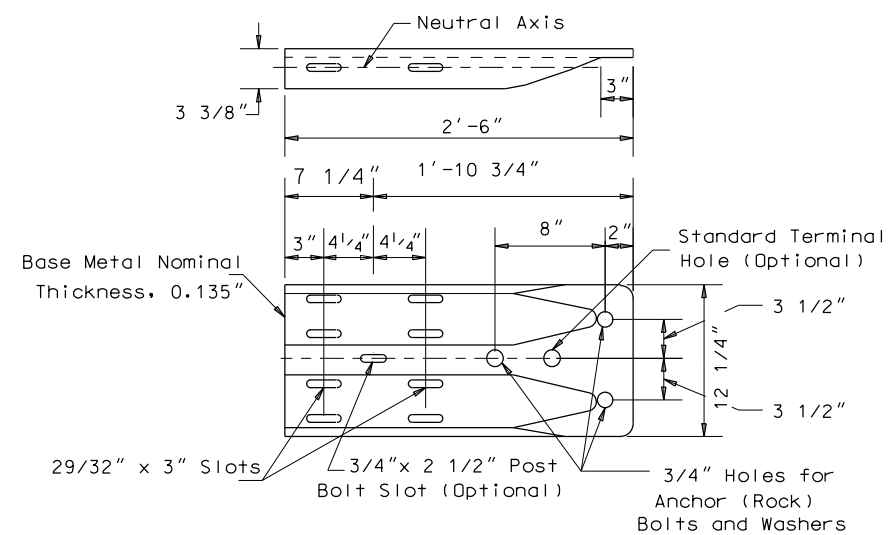

GUARDRAIL END SHOE DETAIL

WEST VIRGINIA DEPARTMENT OF TRANSPORTATION
DIVISION OF HIGHWAYS
STANDARD DETAIL

PREPARED 4/22/15

REVISION DATE

CUT SLOPE TERMINAL
TYPE B INSTALLATION
SHALE OR ROCK

STANDARD SHEET GR4B

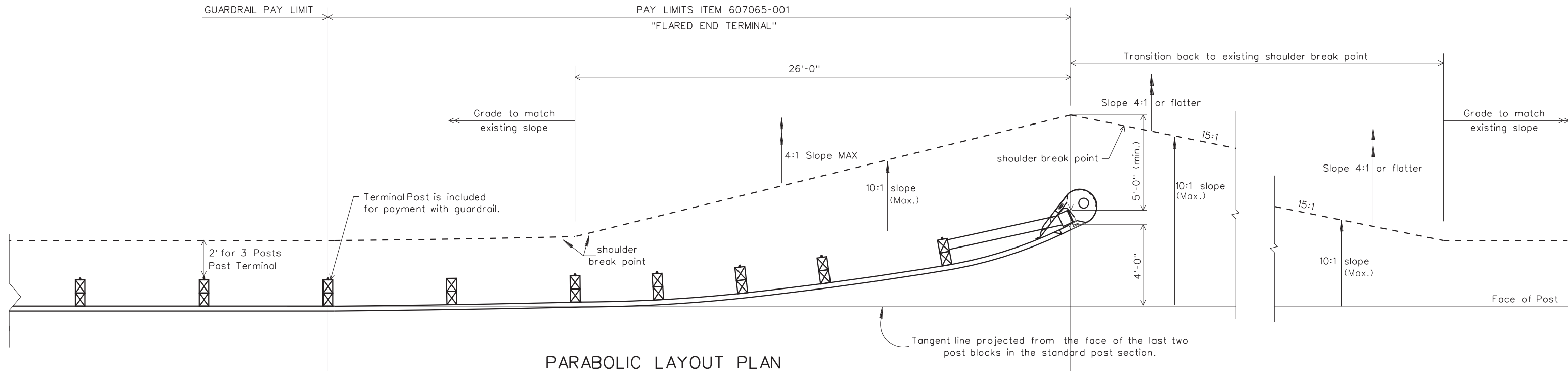

PARABOLIC LAYOUT PLAN

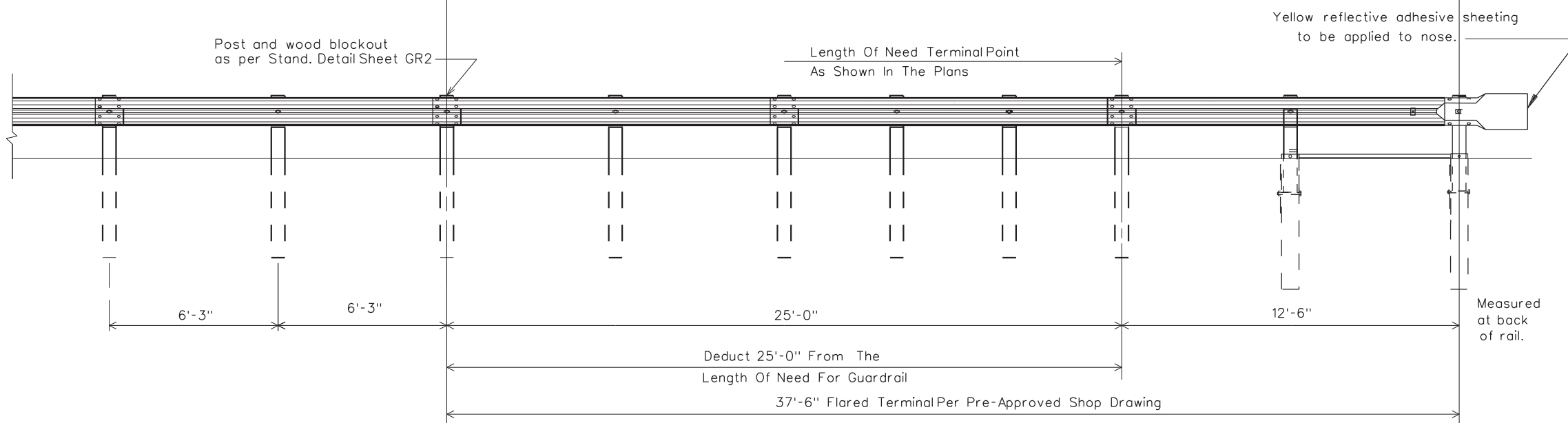

ELEVATION

NOTES

- For details of Flared End Terminal see pre approved shop drawings.
- All materials used shall meet the applicable requirements of Section 607 of the Standard Specifications Road and Bridges.
- The post offset dimensions are given to the center of the traffic face of the blockouts; except at the first post, where the dimension is to the center of the traffic face of the post. Offset points are to be located by measurements at the back of rail equal to the nominal post spacings shown on pre-approved shop drawings. Posts are to be set approximately radial to the railing at each location.
- When a wood block is used adjacent to a wood post, the block shall be nailed to the post with a galvanized steel 10d common nail. The nails to be driven into the center of the top or bottom of the block.
- The cost of furnishing and installing the Flared End Terminal, complete with all miscellaneous hardware and parts as detailed on the pre-approved shop drawings, is to be included in the unit price bid for "Flared End Terminal".
- Yellow reflective sheeting shall cover the entire nose of those terminals with a flat impact head. Those terminals with a rounded impact head shall be covered with a 1'-0" X 3'-0" yellow reflective sheet.

As of 11-13-12 revision date, this detail is obsolete and no longer used for new construction.

WEST VIRGINIA DEPARTMENT OF TRANSPORTATION
DIVISION OF HIGHWAYS
STANDARD DETAIL

PREPARED 7-1-99
REVISION DATE
11-13-12

**FLARED END TERMINAL
PARABOLIC LAYOUT
(SHEET 1 OF 2)**

STANDARD SHEET GR5

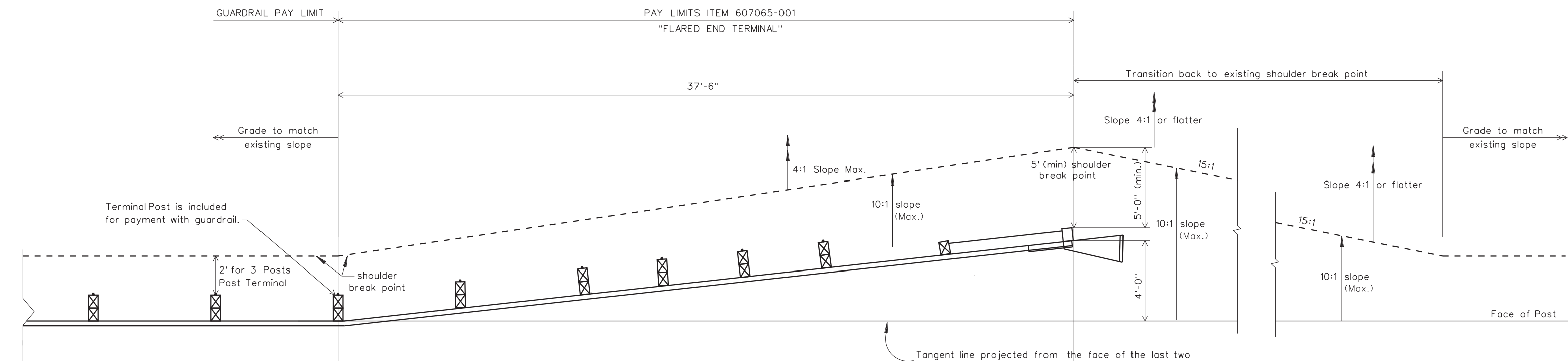

STRAIGHT LAYOUT PLAN

NOTES

- Flared End Terminal shall meet NCHRP-350 and/or Mash testing for appropriate height.
- Separate Approved Product Lists will be maintained for both 28 1/2" and 31" terminal heights.
- For details of Flared End Terminal see pre approved shop drawings.
- Post and splice locations are per manufacturer.
- All materials used shall meet the applicable requirements of Section 607 of the Standard Specifications Road and Bridges.
- The post offset dimensions are given to the center of the traffic face of the blockouts; except at the first post, where the dimension is to the center of the traffic face of the post. Offset points are to be located by measurements at the back of rail equal to the nominal post spacings shown on pre-approved shop drawings. Posts are to be set approximately radial to the railing at each location.
- When a wood block is used adjacent to a wood post, the block shall be nailed to the post with a galvanized steel 10d common nail. The nail is to be driven into the center of the top or bottom of the block.
- The cost of furnishing and installing the Flared End Terminal, complete with all miscellaneous hardware and parts as detailed on the pre-approved shop drawings, is to be included in the unit price bid for "Flared End Terminal".
- Yellow reflective sheeting shall cover the entire nose of those terminals with a flat impact head. Those terminals with a rounded impact head shall be covered with a 1'-0" X 3'-0" yellow reflective sheet.

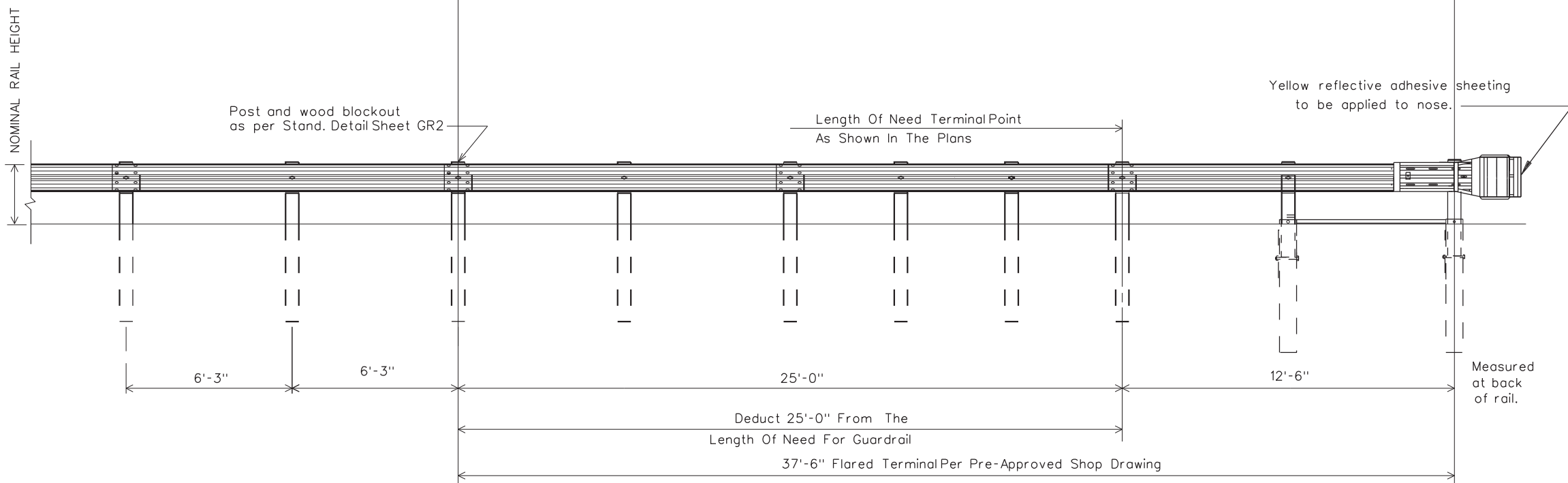

ELEVATION

WEST VIRGINIA DEPARTMENT OF TRANSPORTATION
DIVISION OF HIGHWAYS
STANDARD DETAIL

PREPARED	7-1-99
REVISION DATE	11-13-12

**FLARED END TERMINAL
STRAIGHT LAYOUT**

(SHEET 2 OF 2)

STANDARD SHEET GR5

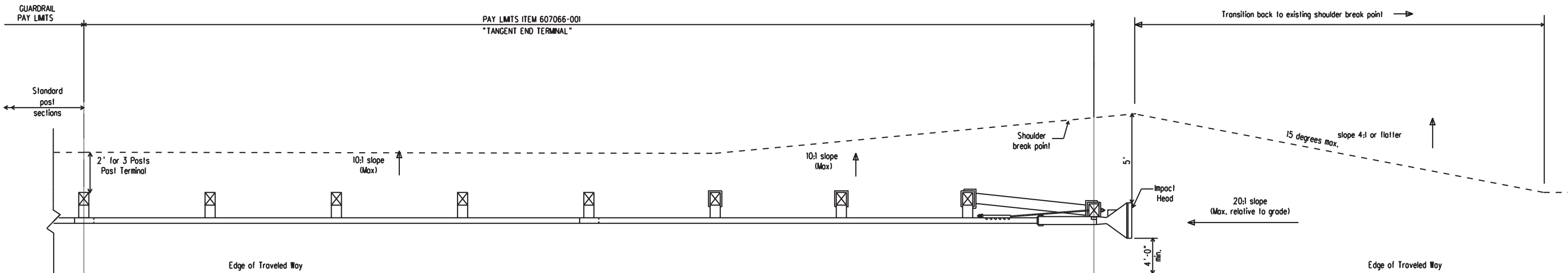

TANGENT END TERMINAL PLAN

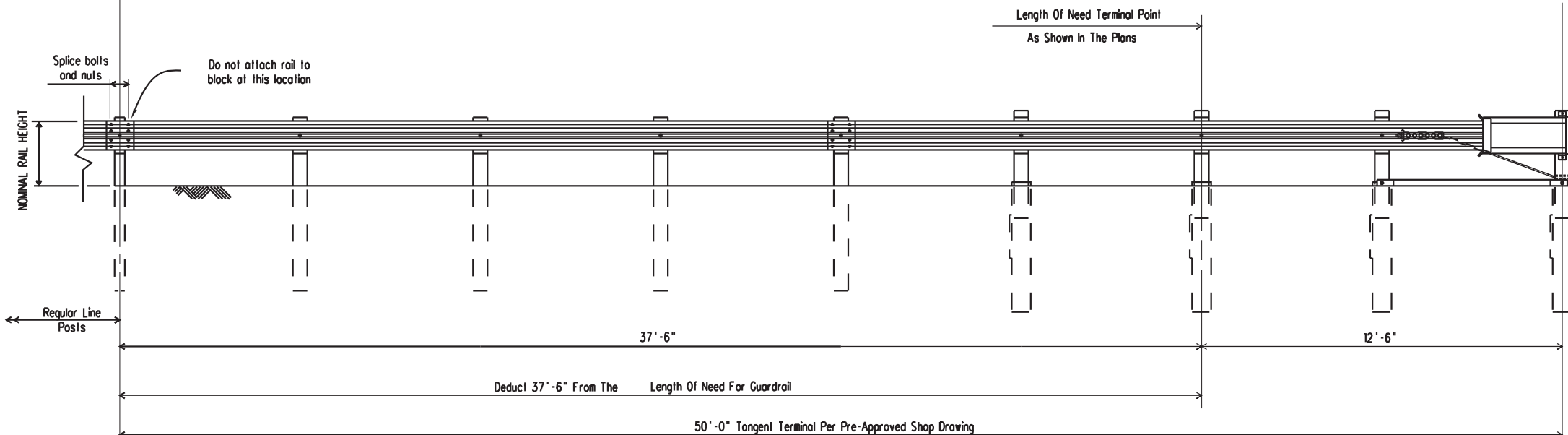

ELEVATION

NOTES:

- Tangent End Terminal shall meet NCHRP-350 and/or Mash testing for appropriate height.
- Separate Approved Product Lists will be maintained for both 28 1/2" and 31" terminal heights.
- Post and splice locations are per manufacturer.
- For details of Tangent End Terminal, see pre-approved shop drawings.
- All materials used shall meet the applicable requirements of Section 607 of the Standard Specifications Roads and Bridges.
- The wood block shall be nailed to the post with a galvanized steel 10d common nail. The nails are to be driven into the center of the top or bottom of the block.
- The Tangent End Terminal installation shall maintain a 4' minimum offset from the edge of the impact head to the edge of the traveled way. For narrow existing shoulders that have an offset of 5' or less from the face of the rail element to the edge of the traveled way, the rail and terminal may be flared from the normal face of rail. The flared offset distance shall be 1' at a taper rate of 25:1, for a total flare length of 25'; or a taper rate of 50:1, for a total flare length of 50' (see Flare Detail).
- Rail element panel lengths shall be 25' only. Shorter lengths shall not be used.
- The cost of furnishing and installing the Tangent End Terminal, complete with all miscellaneous hardware and parts as detailed on the pre-approved shop drawings, is to be included in the unit price bid for "Tangent End Terminal".
- Yellow reflective sheeting shall cover the entire nose of those terminals with a flat impact head. Those terminals with a rounded impact head shall be covered with a 1'-0" X 3'-0" yellow reflective sheet.

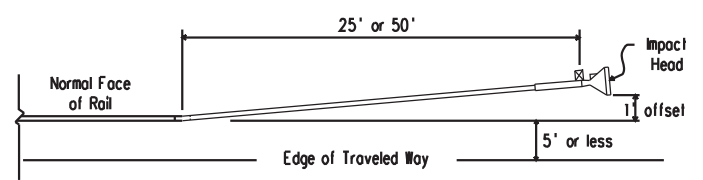

FLARE DETAIL

WEST VIRGINIA DEPARTMENT OF TRANSPORTATION
DIVISION OF HIGHWAYS
STANDARD DETAIL

PREPARED 7-1-99
REVISION DATE
11-13-12

TANGENT END TERMINAL

STANDARD SHEET GR6

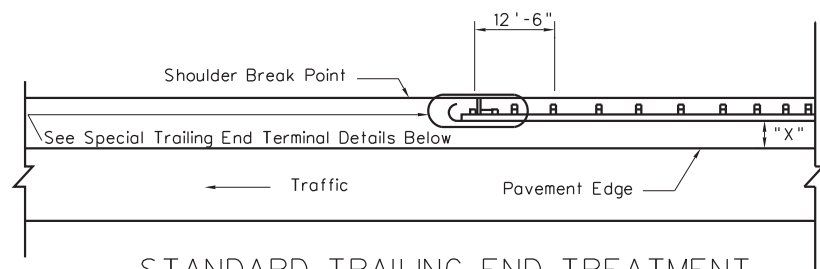

STANDARD TRAILING END TREATMENT
(MULTI-LANE DIVIDED HIGHWAY)

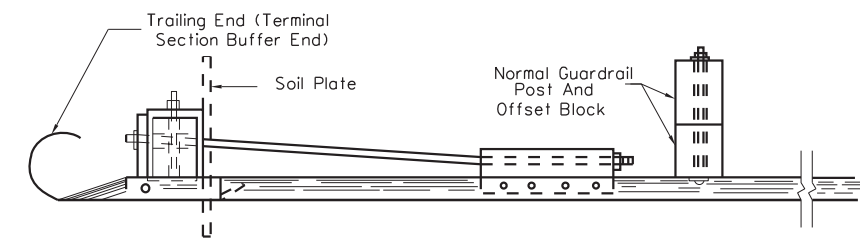

PLAN

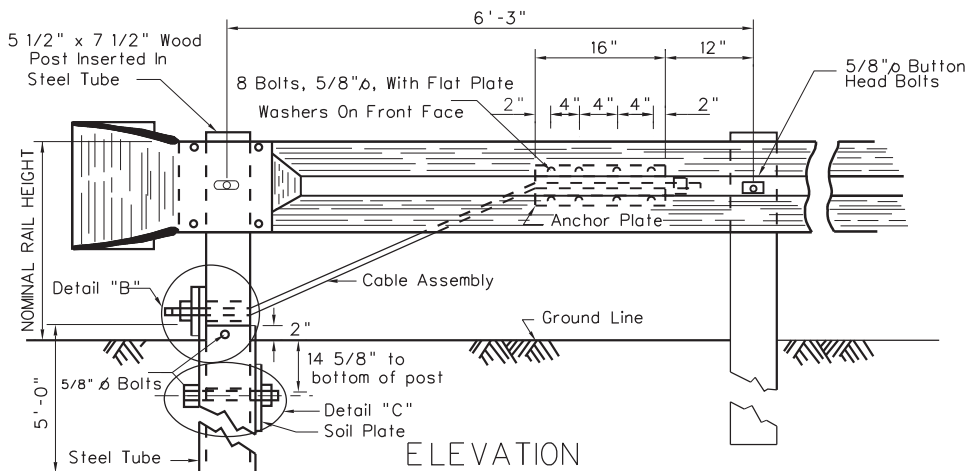

ELEVATION
SPECIAL TRAILING END TERMINAL (STET)
(TUBULAR STEEL END FOUNDATION)

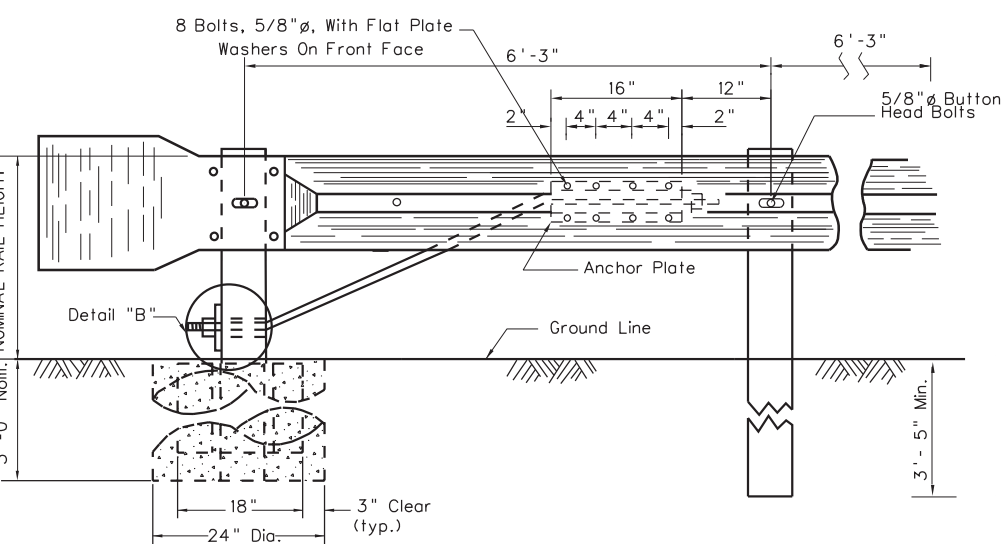

ELEVATION
SPECIAL TRAILING END TERMINAL (STET)
(CONCRETE FOOTER END FOUNDATION)

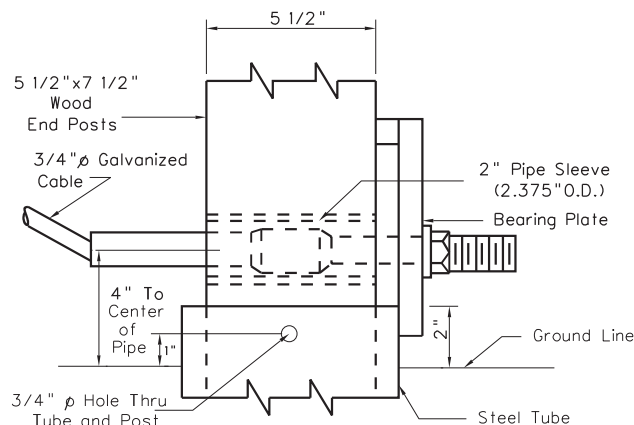

DETAIL "B"

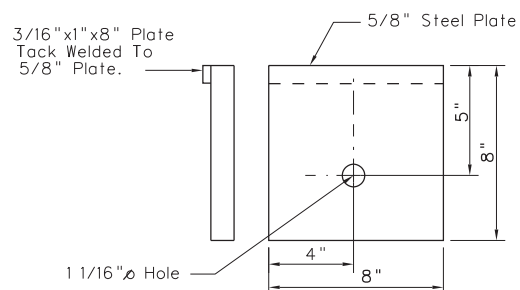

BEARING PLATE

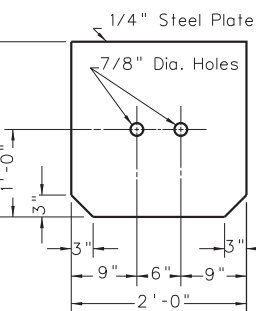

SOIL PLATE

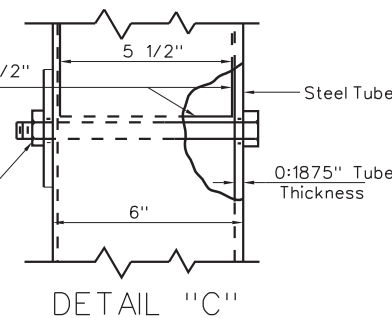

DETAIL "C"

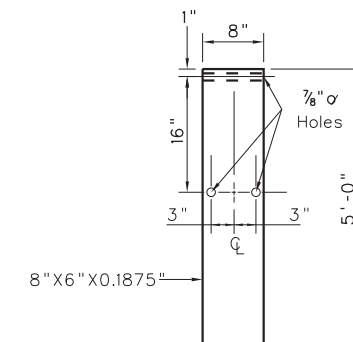

STEEL TUBE

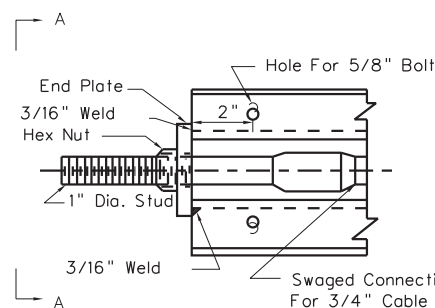

FRONT VIEW
(Rail Removed)

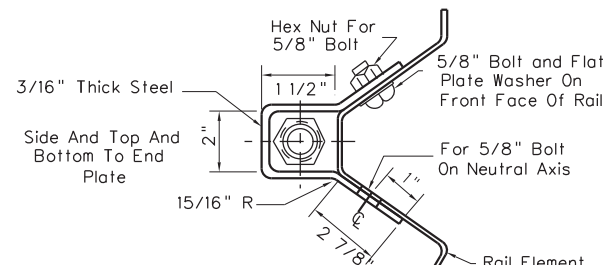

VIEW A-A
(End Plate Removed, Rail Shown)

ANCHOR PLATE DETAIL

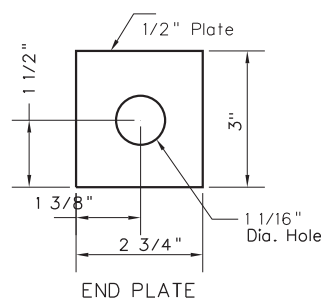

END PLATE

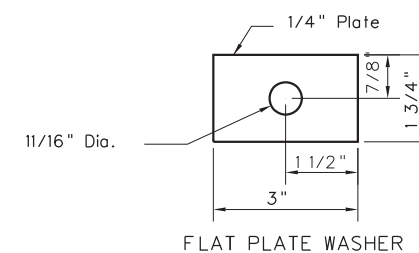

FLAT PLATE WASHER

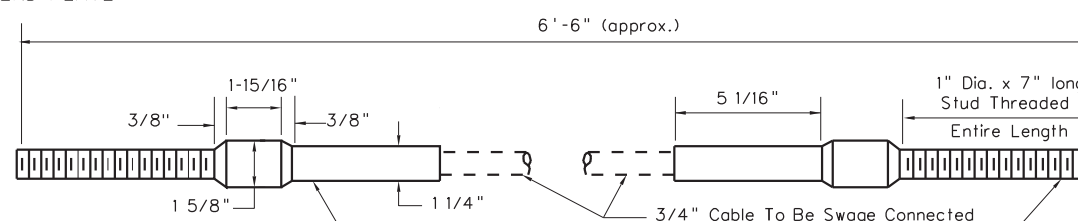

CABLE ASSEMBLY

NOTES

Steel tubes shall meet the requirements of ASTM Specification A500, Grade B, and shall be galvanized after fabrication in accordance with the requirements of AASHTO Specification M111. Other terminal components; such as anchor plates, cable assemblies, hardware, plates, pipe sleeves, etc; shall conform to the detail and requirements of section 607 of the Specifications.

For each STET end treatment installation it shall be the Contractor's option whether to utilize the Tubular Steel End Foundation design detailed herein or Concrete Footer End Foundation design detailed, unless one type is specified in the plans. When the Concrete Footer End Foundation is used, the embedded portion of the Endpost is to be double wrapped with Composition Paper or single wrapped with sheet metal or other material acceptable to the Engineer before concrete placement to facilitate replacement of damaged posts.

The cost of furnishing and installing the Special Trailing End Terminal; including structural tubing, soil plates, and welded bearing plates for Tubular Steel End Foundations; concrete footers, welded wire fabric, all necessary excavation, composition paper and sheetmetal for Concrete Footer End Foundations; and all "terminal" hardware, cables, studs, plates, and pipe sleeves shall be included in the unit price bid for "Special Trailing End Terminal", per each. Normal guardrail components; i.e., posts, blocks, rail elements, hardware, etc; along with the special size and/or special length wood guardrail end post and the terminal section buffer end, shall be paid for as guardrail per linear foot.

WEST VIRGINIA DEPARTMENT OF TRANSPORTATION
DIVISION OF HIGHWAYS
STANDARD DETAIL

PREPARED 7-1-99
REVISION DATE
11-13-2012

SPECIAL TRAILING
END TERMINAL

STANDARD SHEET GR7

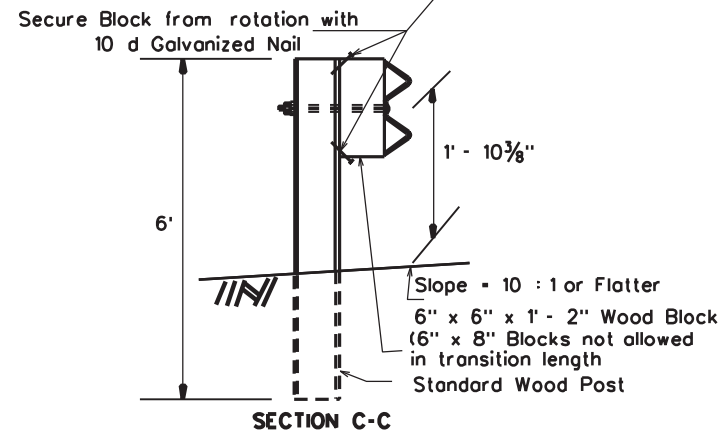
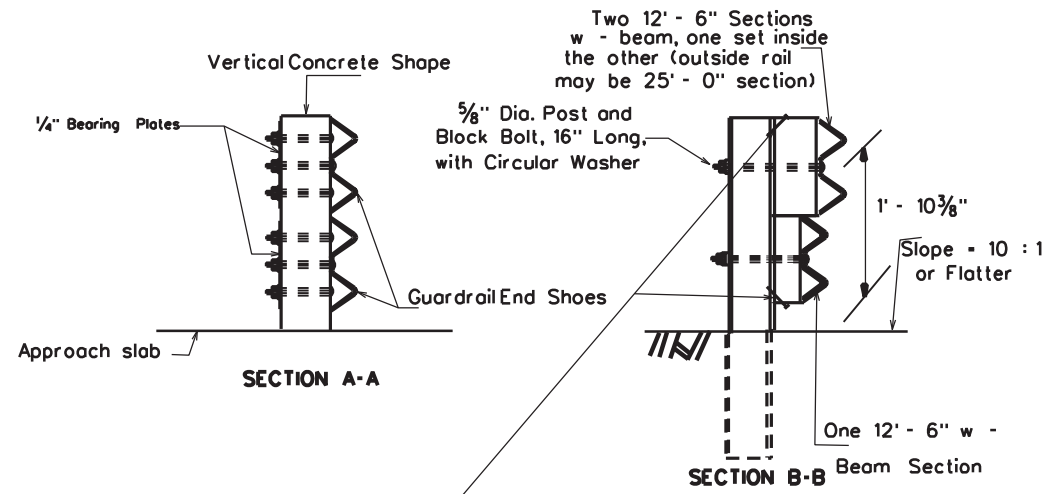
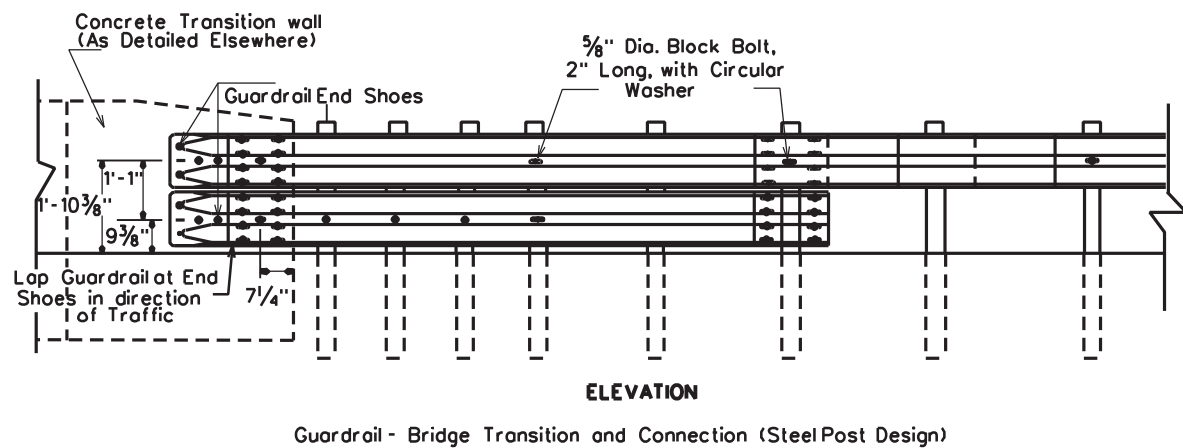
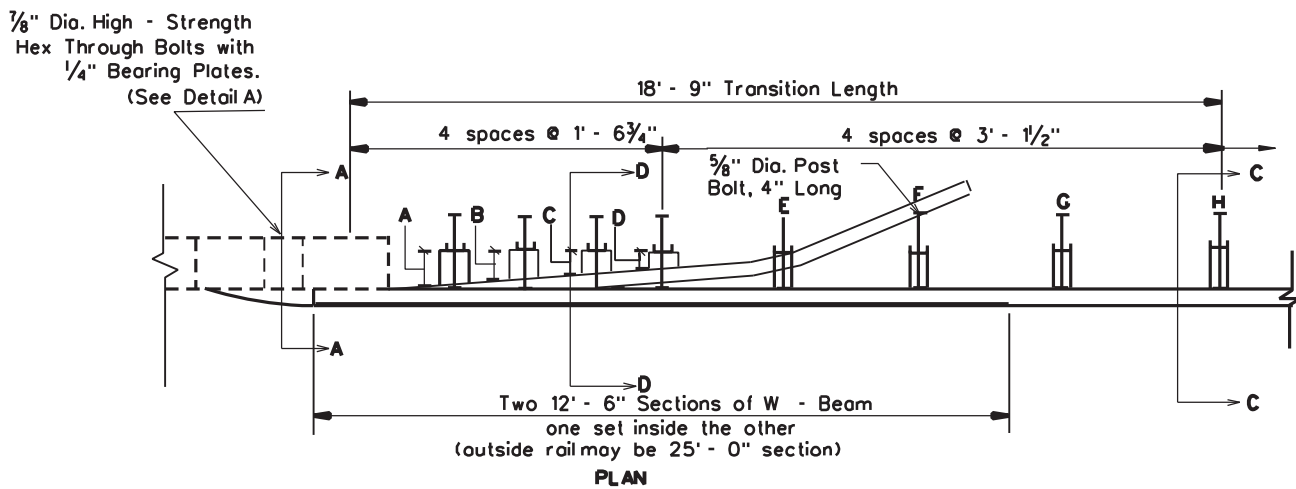
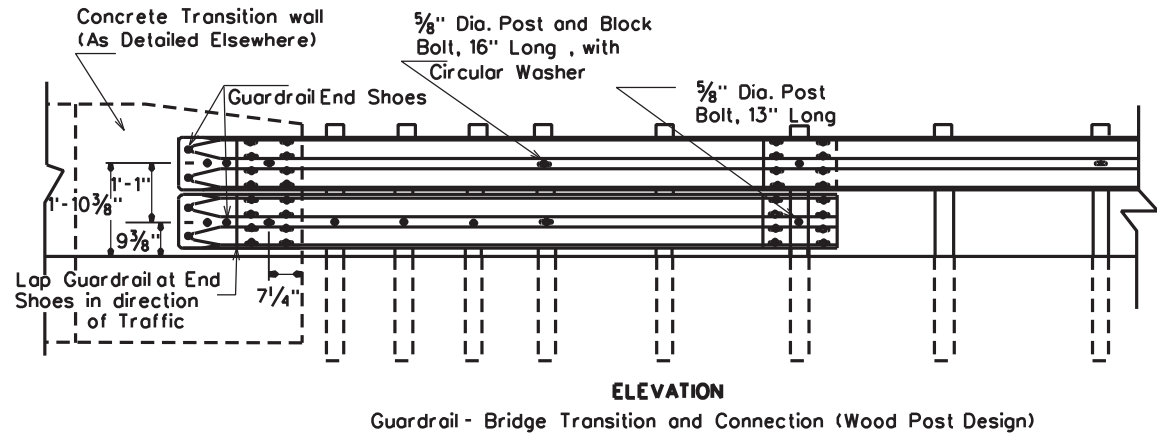
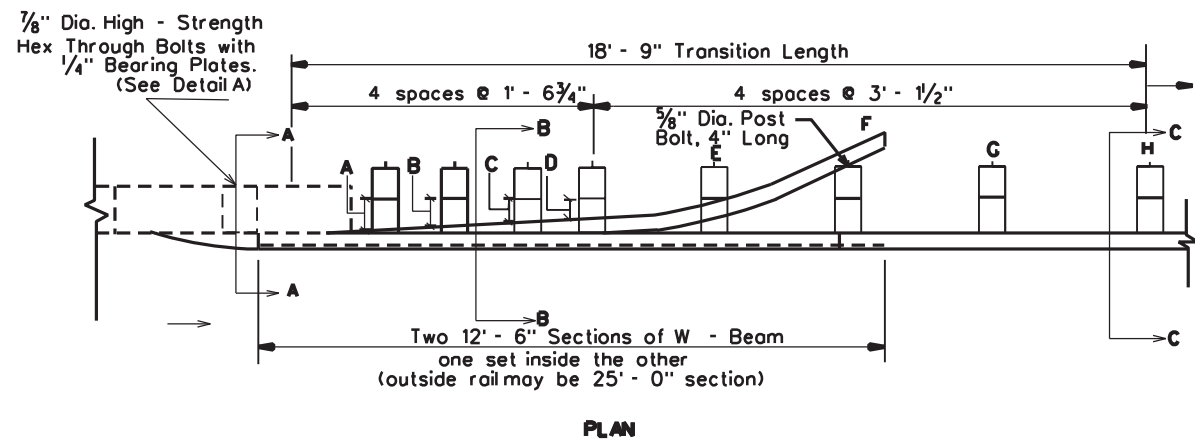

Two 12'-6" Sections w - beam, one set inside the other (outside rail may be 25'-0" section)

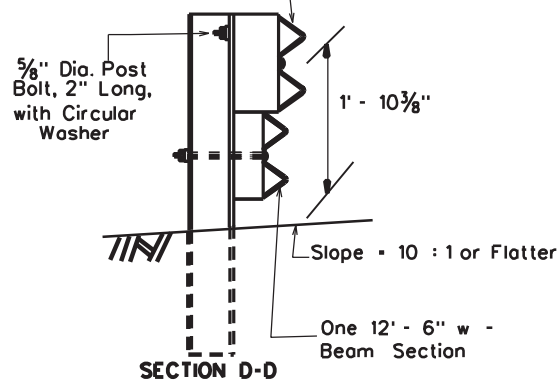

Bottom Beam Wood Blocks (1'-2" x 6")

POST	THICKNESS
A	5"
B	4"
C	3"
D	2"

Table applies to both transition designs.

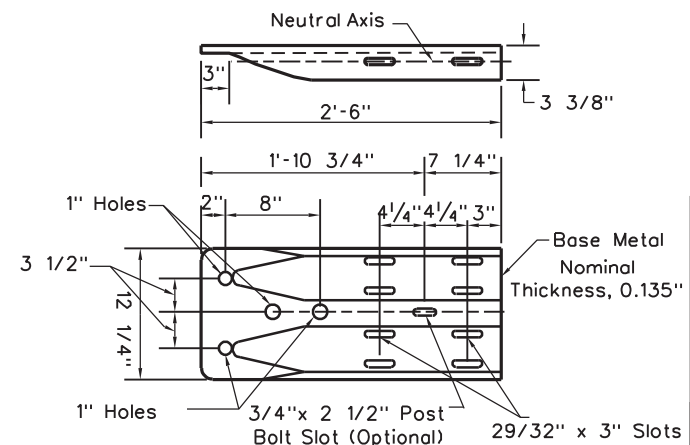
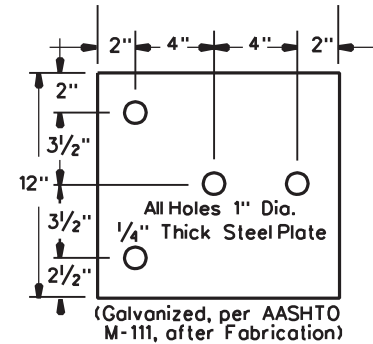

NOTES

These guardrail transitions are appropriate for connection to a vertical concrete shape and should not be connected directly to a concrete safety shape. Concrete safety shape bridge rails or barriers shall be transitioned to a vertical shape at the guardrail connection in a manner detailed elsewhere in the Project Plans.

Although these details may appear to apply strictly to guardrail-to-bridge transitions and connections, they actually can apply to guardrail transitions and connections to concrete barriers, concrete rigid walls or other structures as specified and detailed on the Project Plans.

These details are not required for transitioning guardrail to a bridge when the guardrail is located on the trailing end of a divided highway bridge. Normal guardrail details shall apply.

Installation shall be performed in such a manner as to maintain the rail elements (top w-beams) parallel to the roadway centerline throughout the length of the 18'-9" transition for both designs.

Posts A, B, C, and D require an additional hole to attach bottom blocks and bottom beams. For wood post design the bottom beam wood blocks shall be center drilled and attached with 5/8" diameter post bolts. For steel post design the bottom beam wood blocks shall be offset drilled to sit squarely on the post flange and attached with 5/8" diameter bolts.

For both transitions, the sixth post from the vertical concrete wall shall require an additional hole on the back face of the post to attach the bottom w-beam with 5/8" diameter bolts.

The rubrail (bottom w-beam) may be shop bent for approximately the last three feet to facilitate installation.

A, B, C, E, and G posts and blocks shall not be bolted to the top rail elements; however, posts and blocks shall be bolted and carefully erected to provide firm contact of the blocks against the top rails at these posts.

All bolt holes in all rail sections shall be shop fabricated.

These details are for transitioning 6' 3" post spacing guardrail to a vertical concrete shape. When transitioning 12' 6" post spacing guardrail to a vertical concrete shape, the 25' of rail prior to this 18' 9" transition shall have 6' 3" post spacing.

There is no separate pay item for this connection and all components as detailed herein shall be included in the contract price for guardrail.

WEST VIRGINIA DEPARTMENT OF TRANSPORTATION
DIVISION OF HIGHWAYS
STANDARD DETAIL

PREPARED 7-1-99

REVISION DATE

GUARDRAIL BRIDGE TRANSITIONS AND CONNECTIONS

STANDARD SHEET GR9

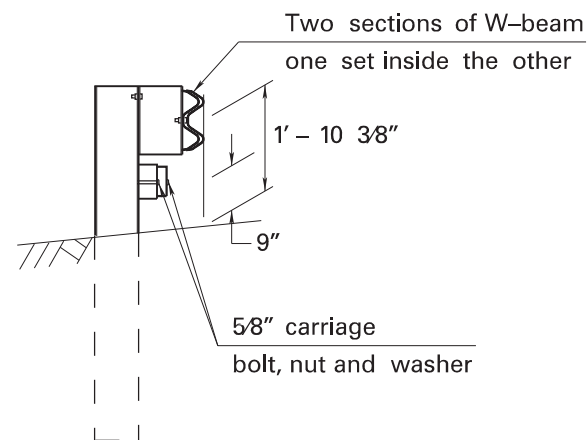

SECTION A-A

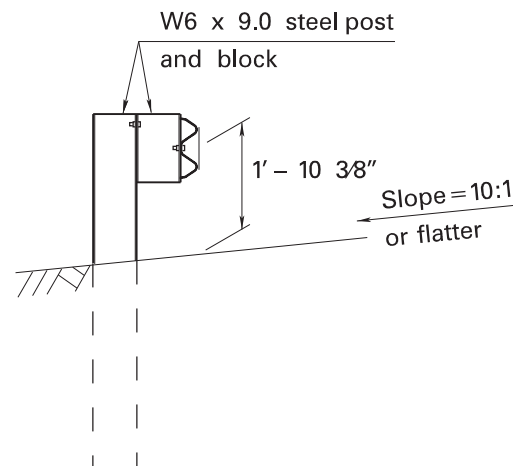

SECTION B-B

RUBRAIL
WOOD BLOCKS
7" X 4"

POST	THICKNESS
1	4 1/2"
2	3 1/2"
3	2"
4	1"

NOTES

1. This guardrail transition is appropriate for connection to a concrete safety shape.
2. Bridge rail ends and bridge parapets must be of adequate strength to accept full impact loading.
3. Posts 1-6 require an additional hole to attach lower blocks and/or rubrail.
4. Rubrail wood blocks located on posts 1 through 4 are offset drilled and secured with 5/8" carriage bolts to posts 2 and 4. : rubrail and posts of posts 1, 3 and 5.
5. W-beam is not bolted to posts at posts 2 through 4 and posts 6 and 8.
6. Steel spacer tube, schedule 40 galvanized pipe, 6" (I.D.) x 9", and attached by a 5/8" carriage bolt and rectangular plate washer.
7. See sheet 3 of 3 for detail. Block is attached by 3/8" X 3" bolt.
8. There is no separate pay item for this connection and all components as detailed herein shall be included in the contract price for guardrail.

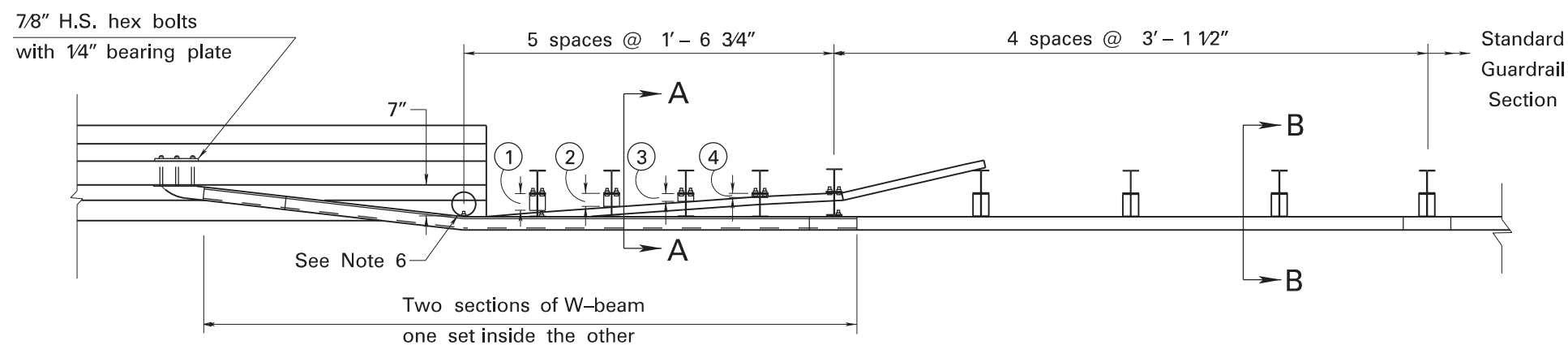

PLAN

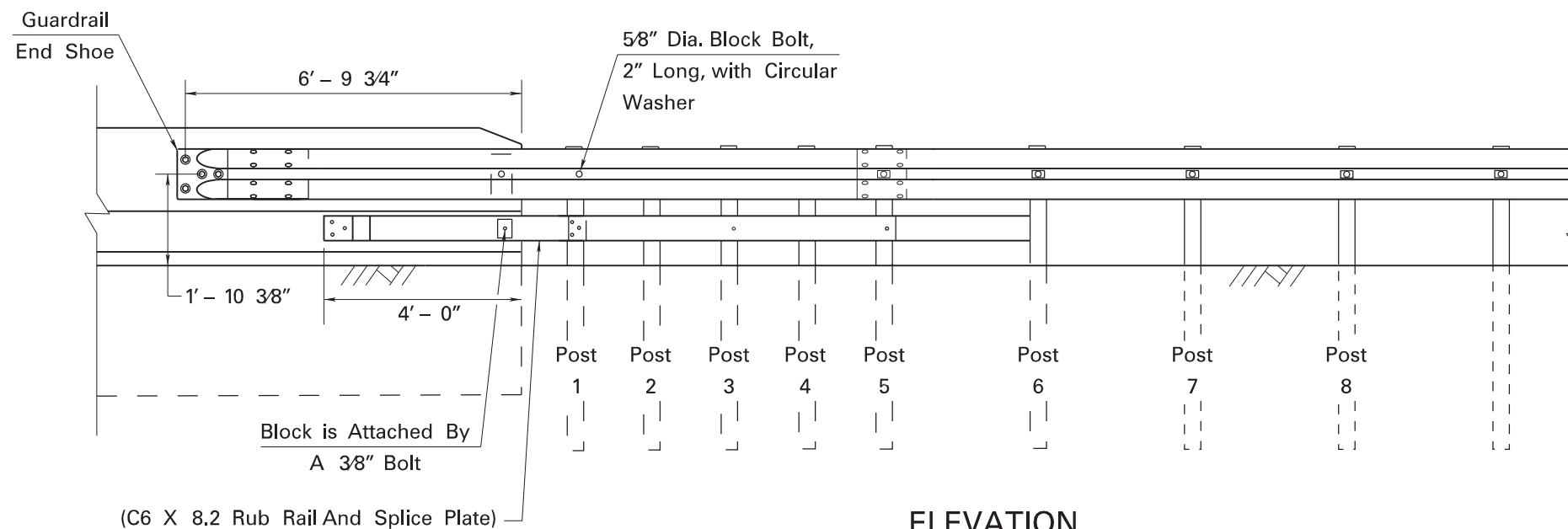

ELEVATION

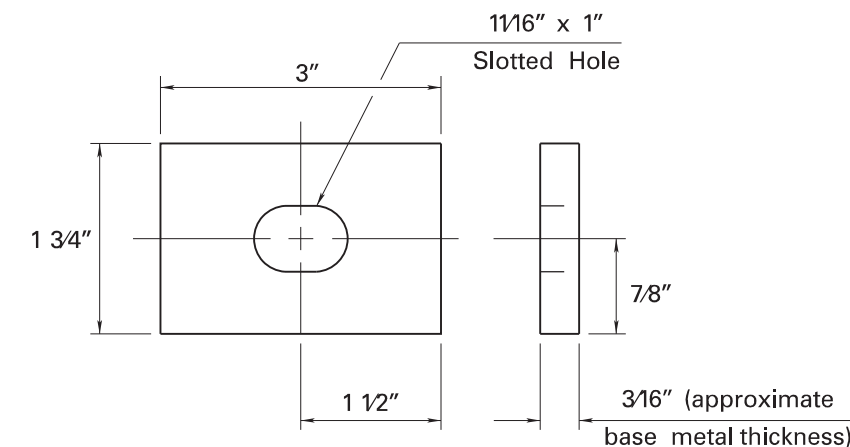

RECTANGULAR PLATE WASHER DETAIL

WEST VIRGINIA DEPARTMENT OF TRANSPORTATION
DIVISION OF HIGHWAYS
STANDARD DETAIL

PREPARED 7-1-99
REVISION DATE

W-BEAM TRANSITION
TO SAFETY SHAPE
WOOD POST WITH RUBRAIL

SHEET 1 OF 3
STANDARD SHEET GR10

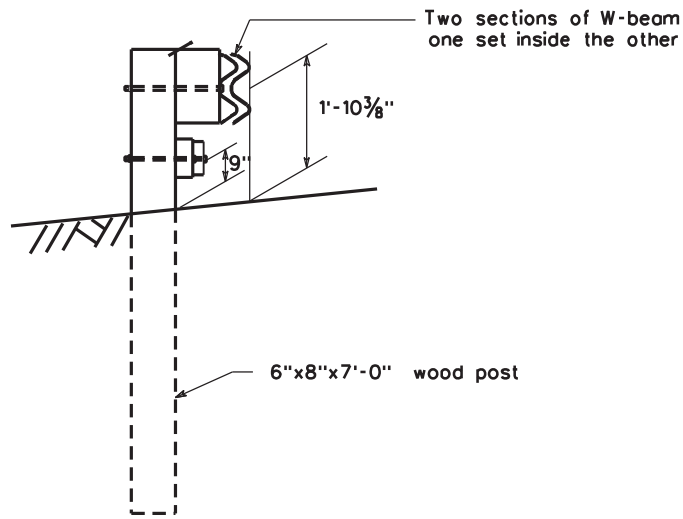

SECTION A-A

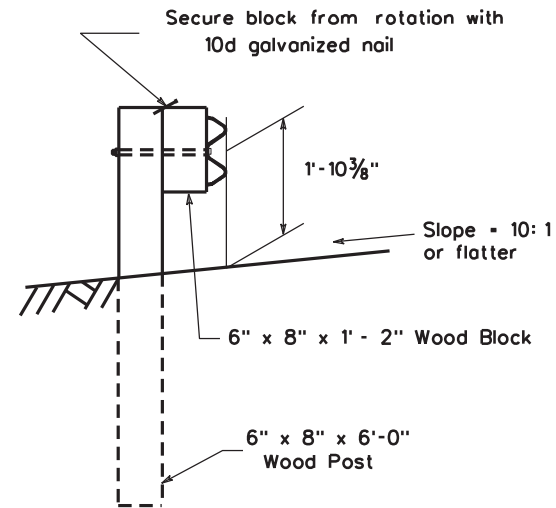

SECTION B-B

Rubrail
Wood Blocks 7" x 6"

POST	THICKNESS
1	6 1/4"
2	4 5/8"
3	3 1/8"
4	1 1/2"

NOTES

1. This guardrail transition is appropriate for connection to a concrete safety shape.
2. Bridge rail ends and bridge parapets must be of adequate strength to accept full impact loading.
3. Rubrail wood blocks, located on posts 1 through 4 are center drilled and secured with 5/8" carriage bolts.
4. Posts 1 through 5 require an additional hole to attach lower blocks and/or lower rubrail.
5. W-beam is not bolted to posts and blocks at posts 2, 3, 4, 6, and 8. Blocks are bolted directly to posts.
6. Steel spacer tube, schedule 40 galvanized pipe, 6" (I.D.) x 9", attached by a 5/8" carriage bolt, and rectangular plate washer.
7. See Sheet 3 of 3 for detail. Block is attached by a 3/8" x 3" bolt.
8. There is no separate pay item for this connection and all components as detailed herein shall be included in the contract price for guardrail.

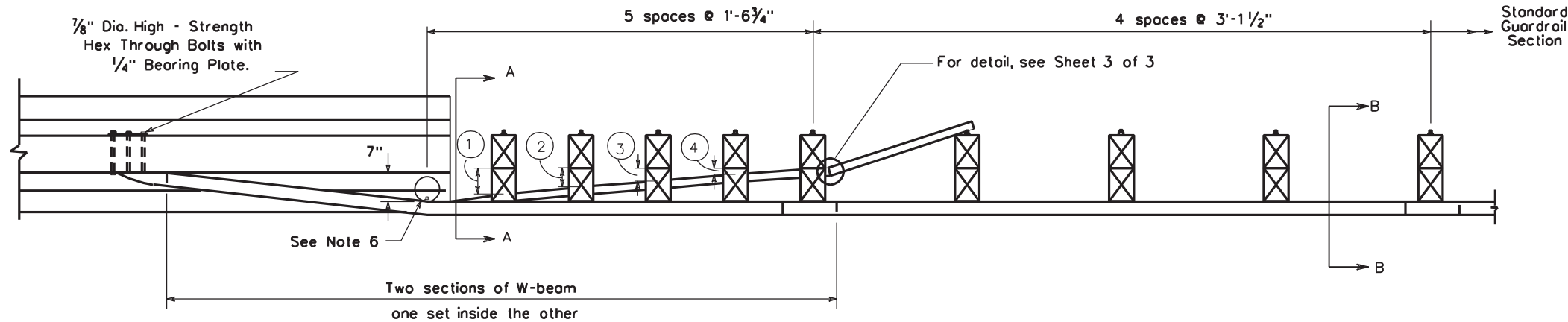

PLAN

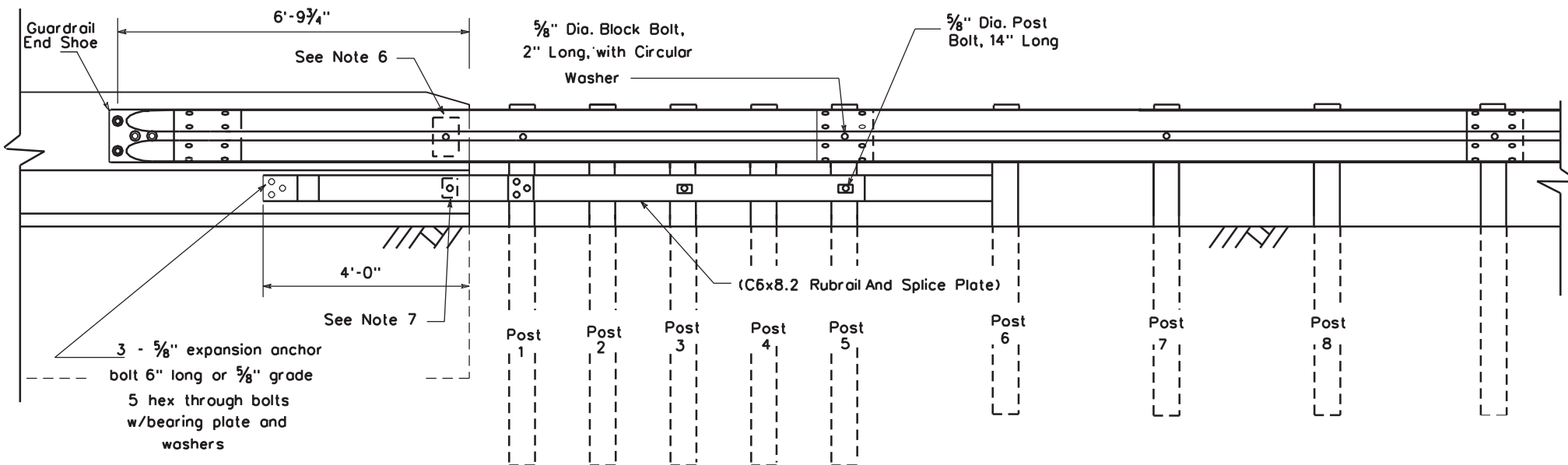

ELEVATION

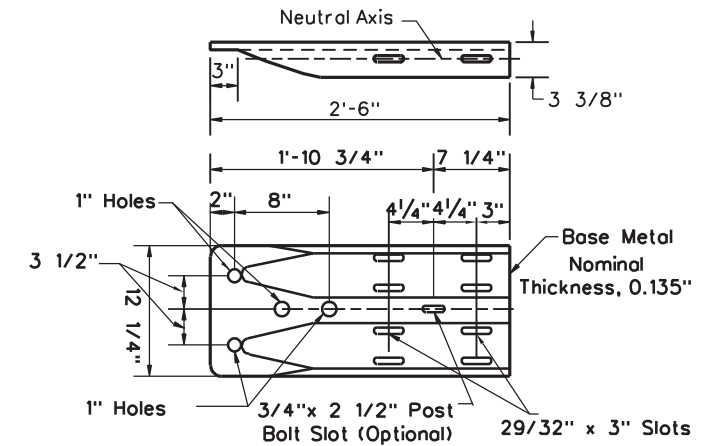

GUARDRAIL END SHOE DETAIL

WEST VIRGINIA DEPARTMENT OF TRANSPORTATION
DIVISION OF HIGHWAYS
STANDARD DETAIL

PREPARED 7-1-99
REVISION DATE

W-BEAM TRANSITION
TO SAFETY SHAPE
WOOD POST WITH RUBRAIL

SHEET 2 OF 3
STANDARD SHEET GR10

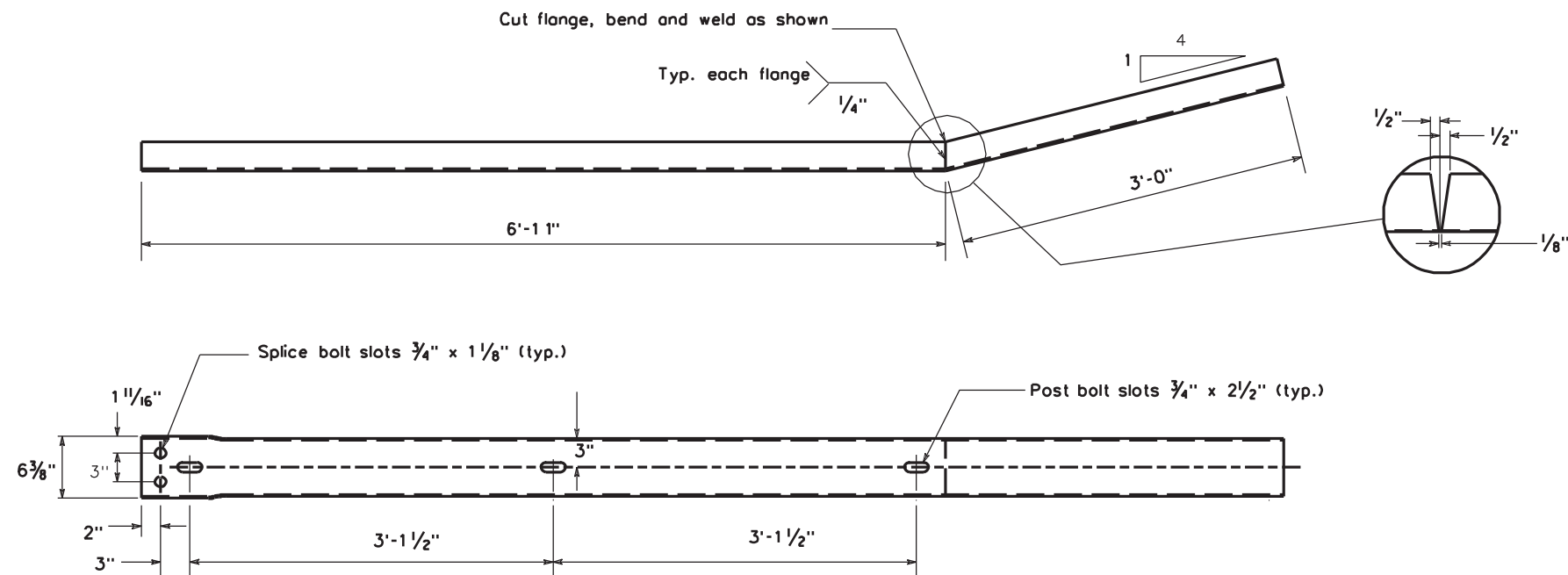

BENT PLATE RUBRAIL DETAIL

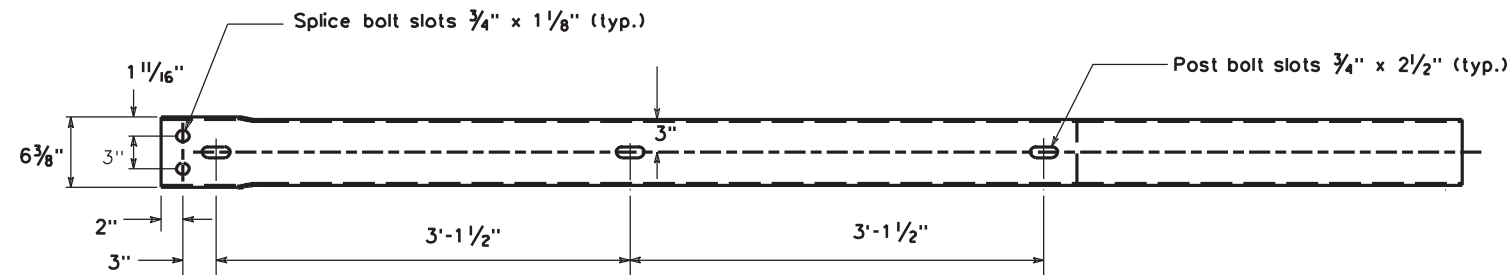

C6X8.2 RUBRAIL
DETAIL

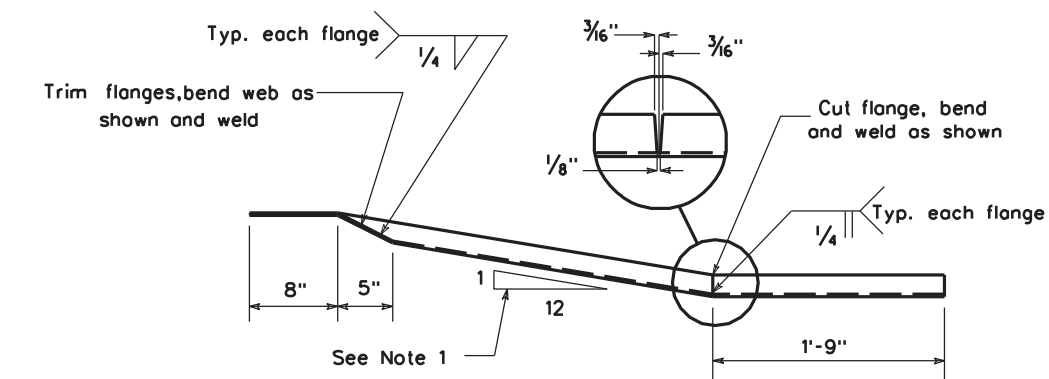

WOOD BLOCKOUT FOR RUBRAIL
DETAIL

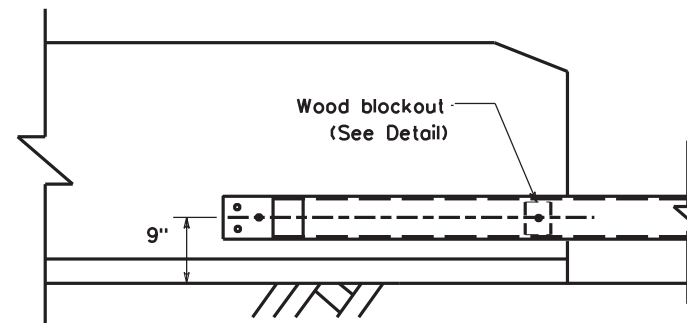

RUBRAIL ATTACHMENT
TO SAFETY SHAPE

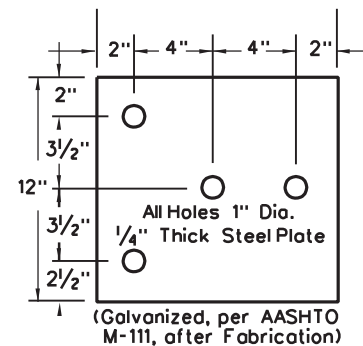
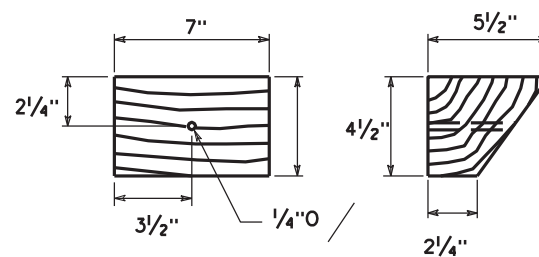

BEARING PLATE
DETAIL

NOTES

1. Rubrail end must be attached flush with sloped toe of safety shape. Installation can be greatly simplified by fabricating or shop twisting the rubrail end to be consistent with the slope of safety shape. Rubrail ends twisted both clockwise and counterclockwise may be required in most situations.
2. The rubrail end attachment to the concrete safety shape requires three closely drilled holes. appropriate epoxy bolt anchors should be used to reduce the risk of splitting the concrete.
3. There is no separate pay item for this connection and all components as detailed herein shall be included in the contract price for guardrail.

WEST VIRGINIA DEPARTMENT OF TRANSPORTATION
DIVISION OF HIGHWAYS
STANDARD DETAIL

PREPARED 7-1-99
REVISION DATE

W-BEAM TRANSITION
TO SAFETY SHAPE
RUBRAIL DETAILS

NOTES

This guardrail transition is appropriate for connection to a vertical concrete shape and should not be connected directly to a concrete safety shape. Concrete safety shape bridge rails or barriers shall be transitioned to a vertical shape at the guardrail connection in a manner detailed elsewhere in the Project Plans.

The two sections of 12'6" thrie beam require additional holes in order to mount the beam to the post nearest to the concrete wall.

See Sheet GR II-C for details not shown on this sheet.

Guardrail systems must have met either the NCHRP 350 or the most current AASHTO Manual for Assessing Safety Hardware (MASH) crash testing criteria and have an FHWA eligibility letter to be used on WVDOH projects. Only FHWA approved guardrail systems utilizing wood or approved block-outs shown on the Division's "Approved Source/Product Listing" shall be used. Steel "W" Shapes shall not be used for block-outs. Only one type of block shall be used for blockout throughout any project, unless otherwise specified.

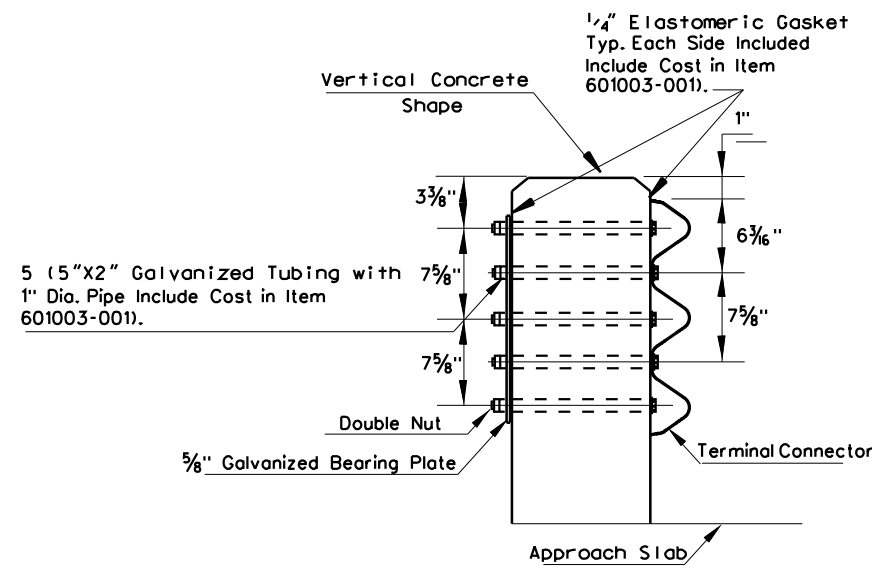

SECTION A-A

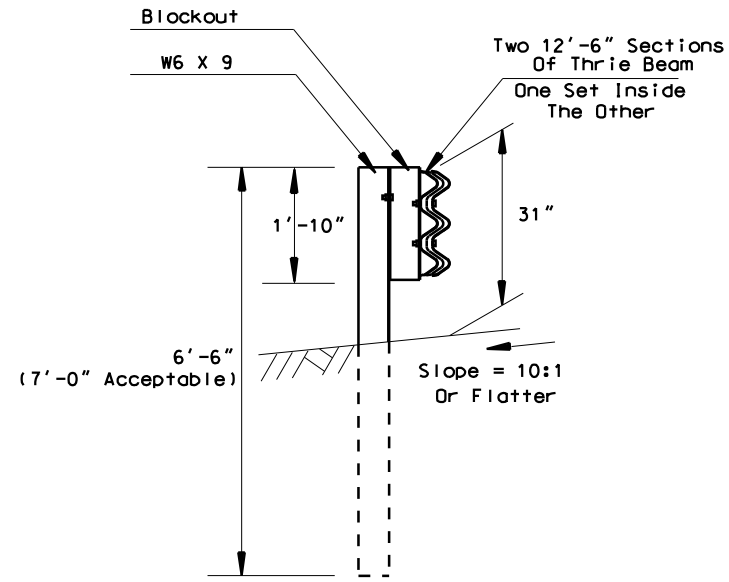

SECTION B-B

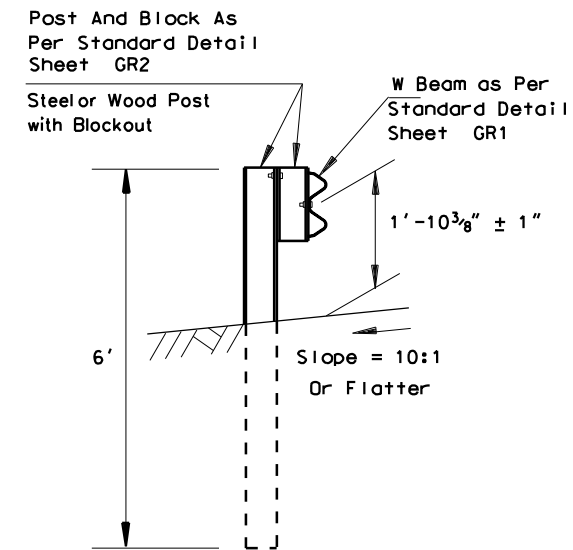

SECTION C-C

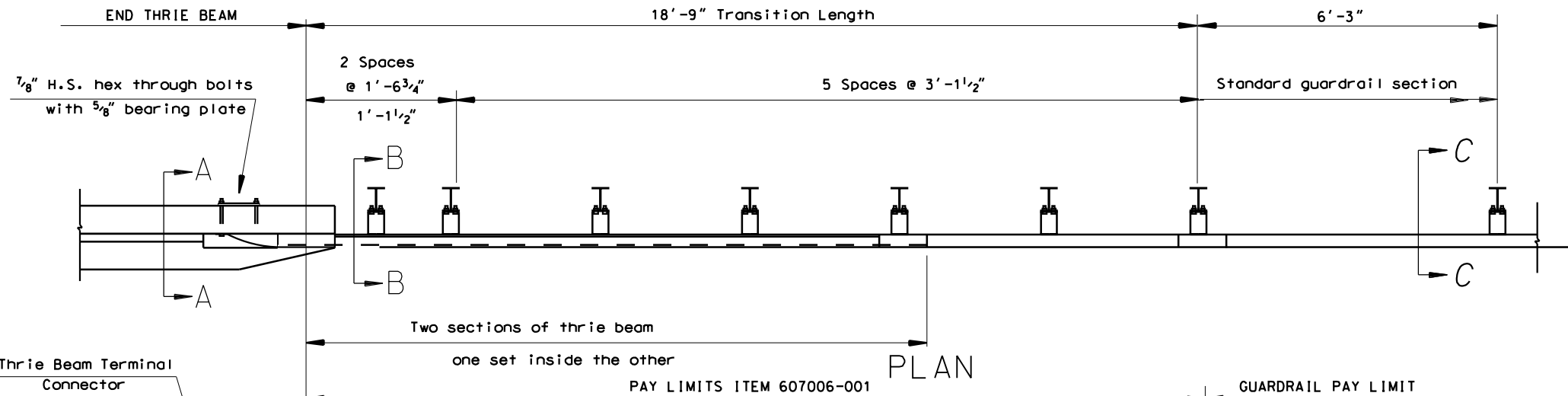

PLAN

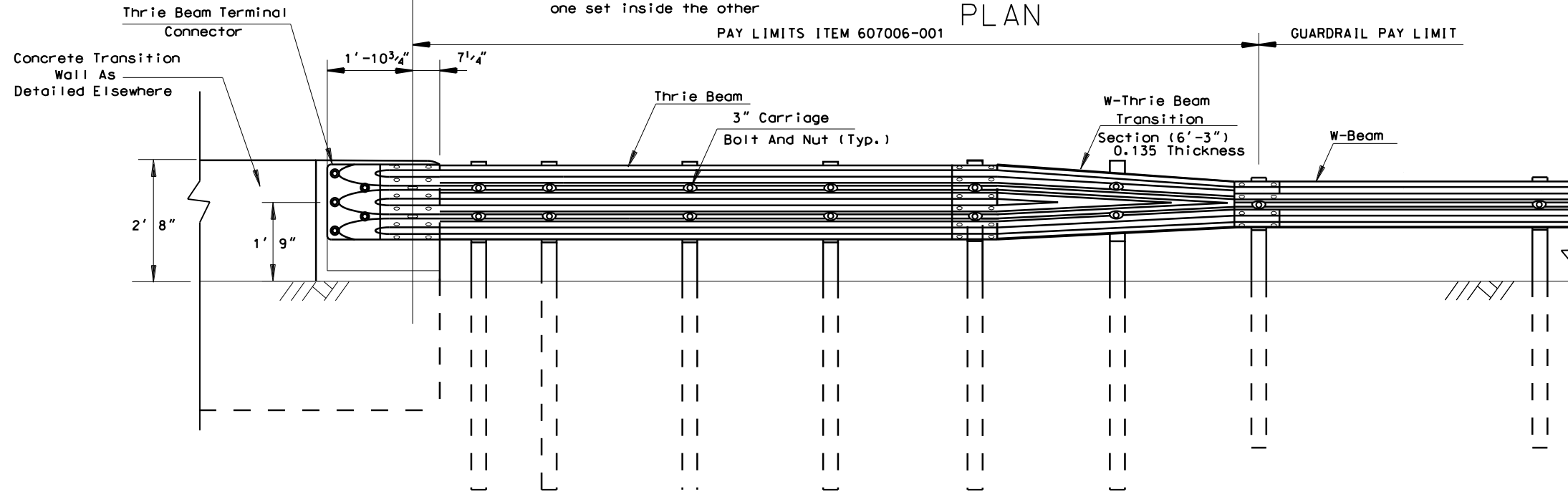

ELEVATION

28 1/2" TOP OF RAIL HEIGHT

WEST VIRGINIA DEPARTMENT OF TRANSPORTATION
DIVISION OF HIGHWAYS
STANDARD DETAIL

PREPARED	7-1-99
REVISION DATE	
	03-11-2010
	11-13-12

THRIE BEAM
GUARDRAIL BRIDGE
TRANSITION AND
CONNECTION

STANDARD SHEET GR 11-A

NOTES

THIS GUARDRAIL TRANSITION IS APPROPRIATE FOR CONNECTION TO A VERTICAL CONCRETE SHAPE AND SHOULD NOT BE CONNECTED DIRECTLY TO A CONCRETE SAFETY SHAPE. CONCRETE SAFETY SHAPE BRIDGE RAILS OR BARRIERS SHALL BE TRANSITIONED TO A VERTICAL SHAPE AT THE GUARDRAIL CONNECTION ON A MANNER DETAILED ELSEWHERE IN THE PROJECT PLANS.

THE TWO SECTIONS OF 12' 6" THRIE BEAM REQUIRE ADDITIONAL SLOTTED HOLES IN ORDER TO MOUNT THE BEAM TO THE POST NEAREST TO THE CONCRETE WALL.

ONLY BLOCK-OUTS SHOWN ON THE DIVISION'S "APPROVED SOURCE/PRODUCT LISTING" SHALL BE USED. STEEL "W" SHAPES SHALL NOT BE USED FOR BLOCK-OUTS. ONLY ONE TYPE OF BLOCK SHALL BE USED THROUGHOUT ANY PROJECT, UNLESS OTHERWISE SPECIFIED.

SEE SHEET GR 11-C FOR DETAILS NOT SHOWN ON THIS SHEET.

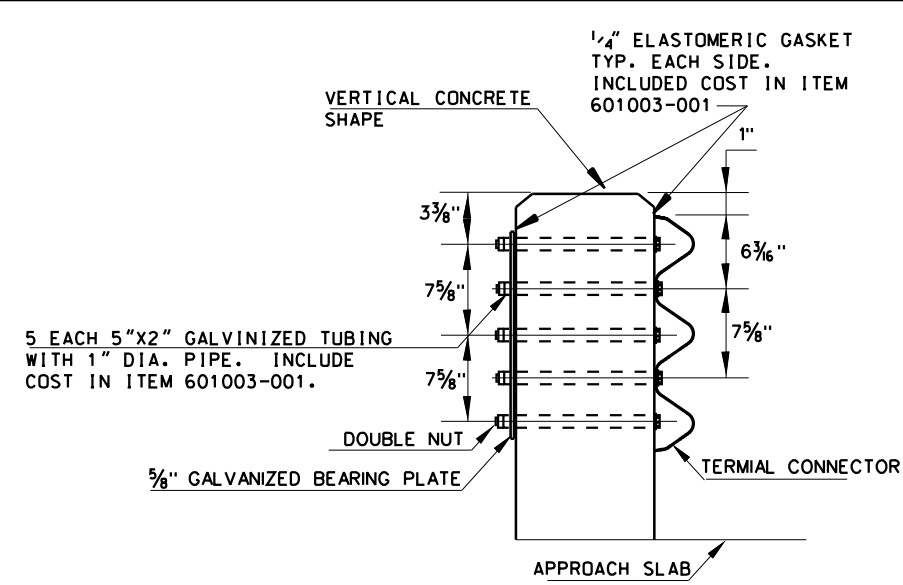

SECTION A-A

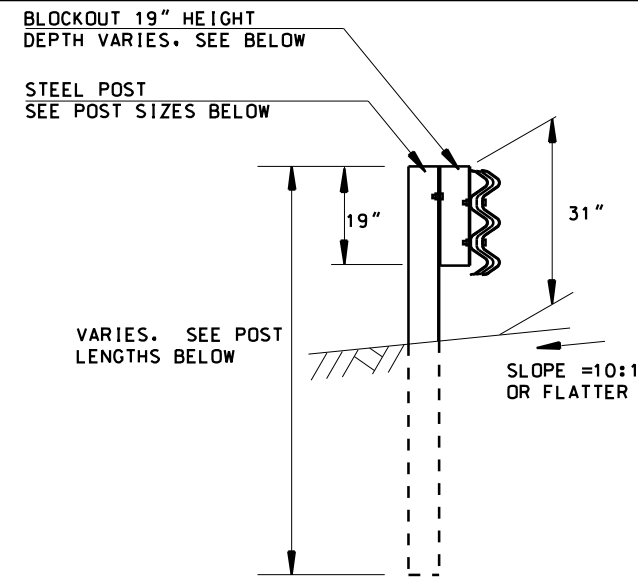

SECTION B-B

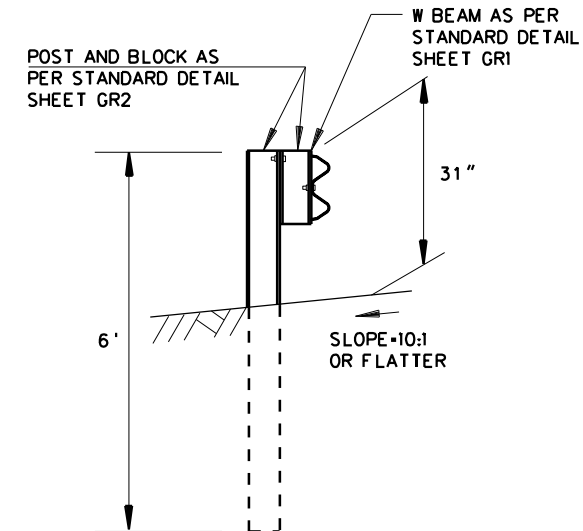

SECTION C-C

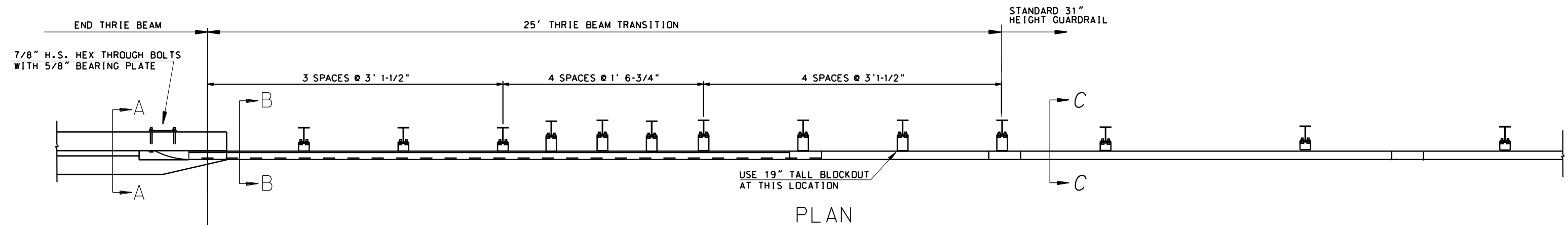

PLAN

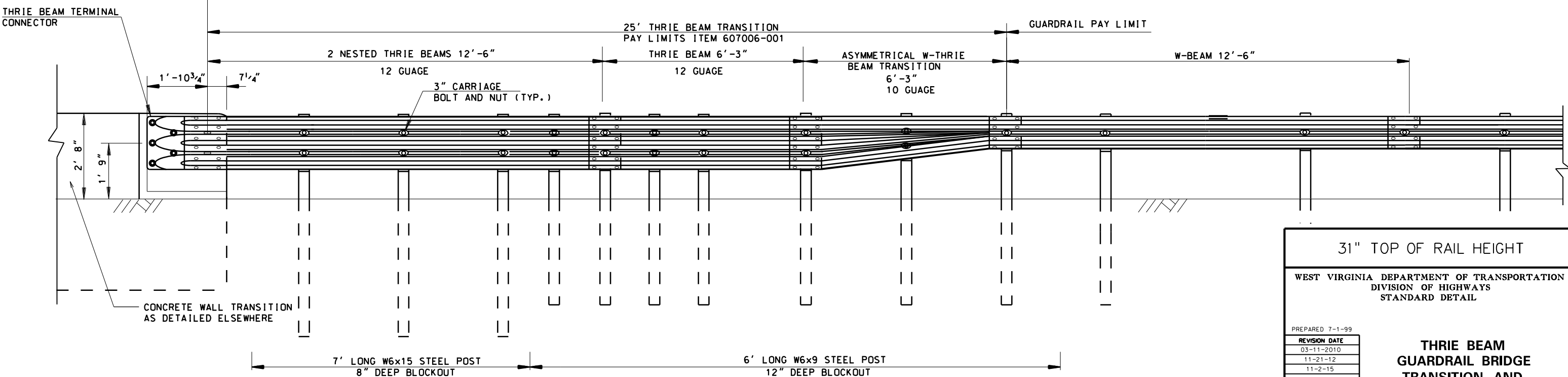

ELEVATION

31" TOP OF RAIL HEIGHT

WEST VIRGINIA DEPARTMENT OF TRANSPORTATION
DIVISION OF HIGHWAYS
STANDARD DETAIL

PREPARED 7-1-99

REVISION DATE
03-11-2010
11-21-12
11-2-15

**THRIE BEAM
GUARDRAIL BRIDGE
TRANSITION AND
CONNECTION**

SHEET GR 11-B

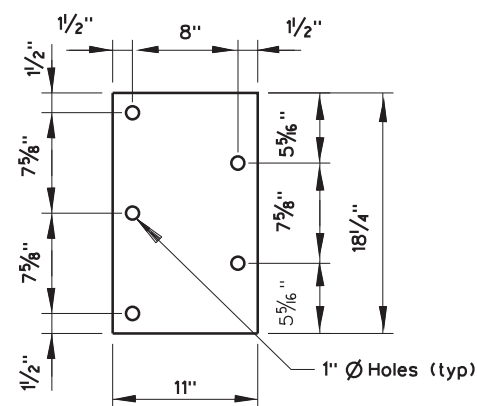

5/8" BEARING PLATE DETAIL

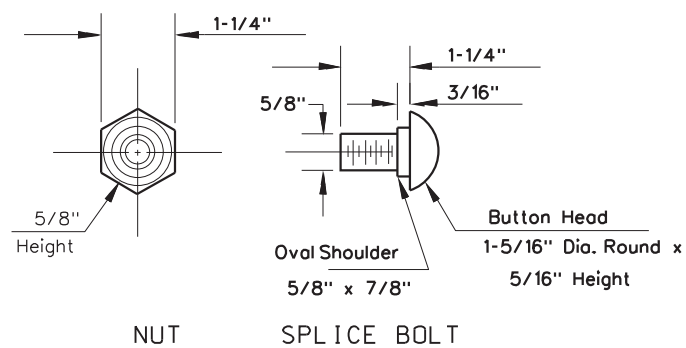

NUT AND SPLICE BOLT DETAIL
(POST BOLT: Similar Except Length)

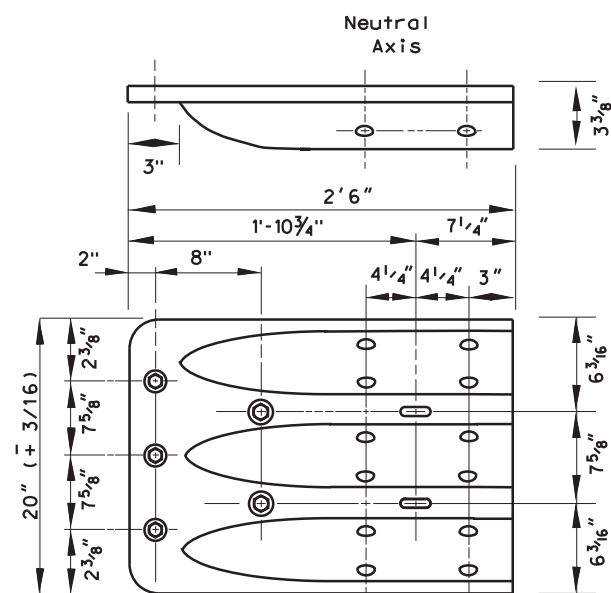

THRIE BEAM TERMINAL CONNECTOR DETAIL

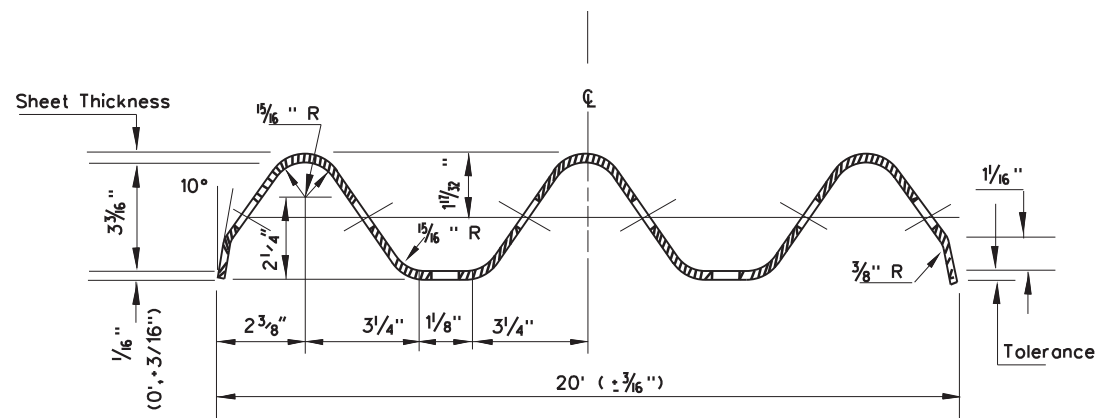

SECTION THRU THRIE BEAM RAIL ELEMENT

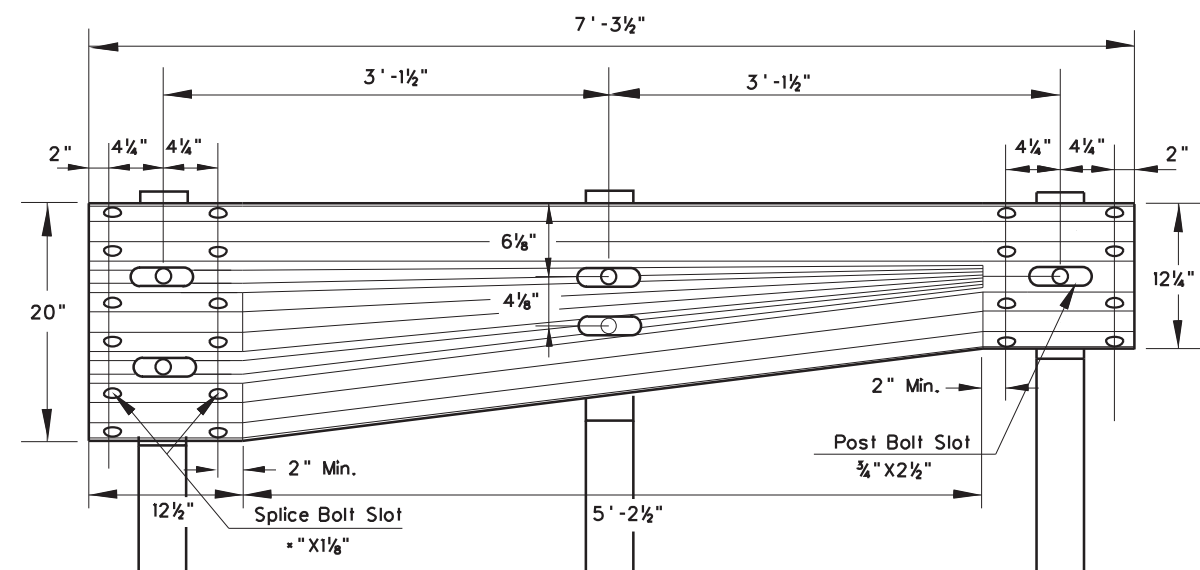

ASYMMETRICAL TRANSITION SECTION DETAIL
(THRIE BEAM TO 31" HEIGHT W-BEAM)

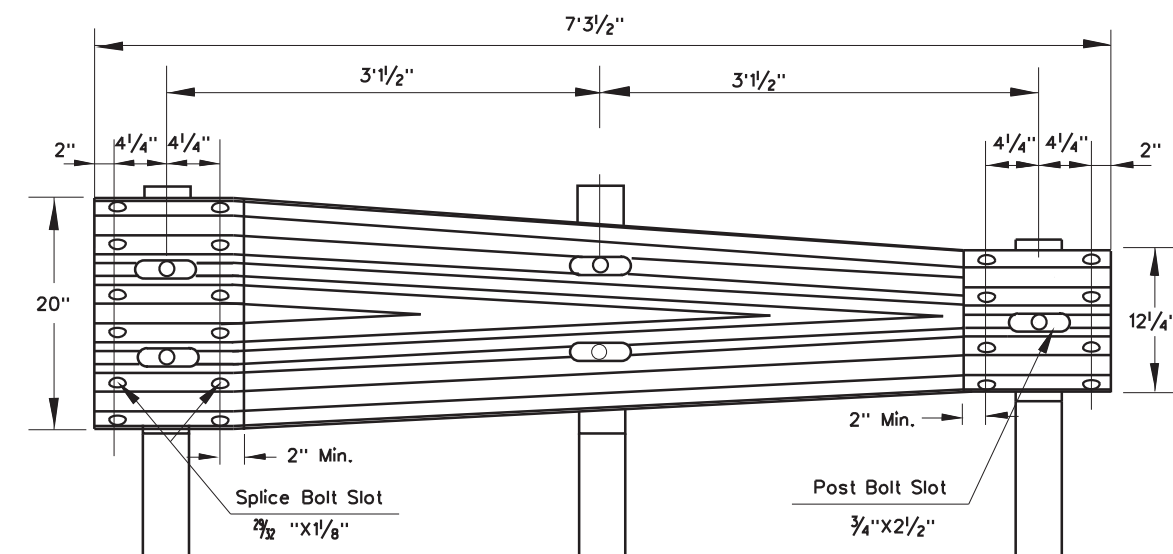

TRANSITION SECTION DETAIL
(THRIE BEAM TO 28-1/2" W-BEAM)

WEST VIRGINIA DEPARTMENT OF TRANSPORTATION
DIVISION OF HIGHWAYS
STANDARD DETAIL

PREPARED 7-1-99
REVISION DATE

**THRIE BEAM
GUARDRAIL BRIDGE
TRANSITION AND
CONNECTION**

STANDARD SHEET GR11-C

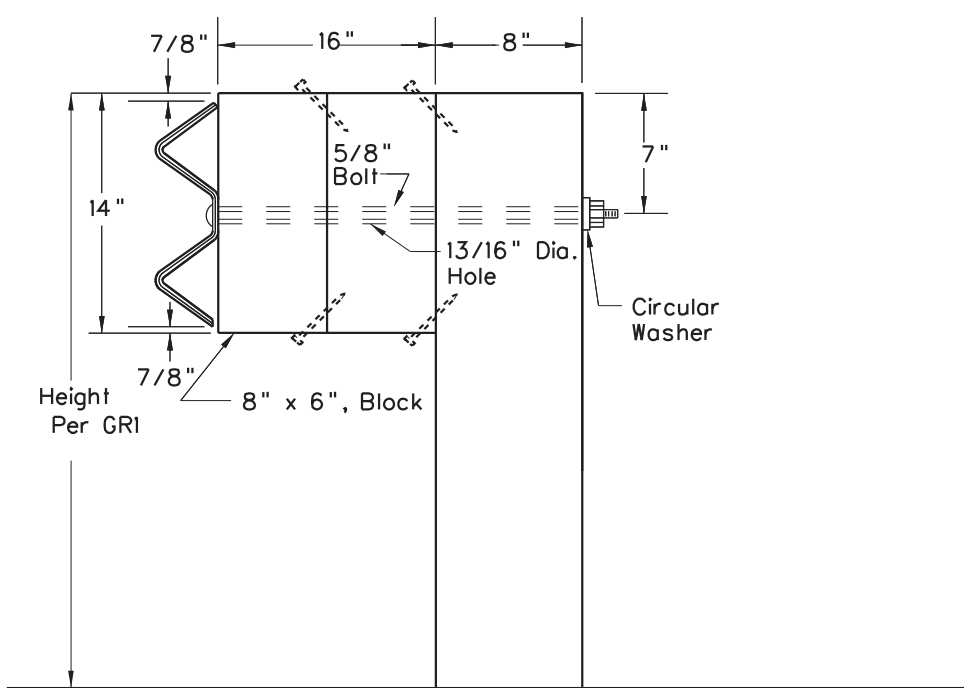

DETAIL FOR 16" BLOCKOUT DEPTH

It is acceptable to use blockouts up to 16" deep to increase the post offset to avoid underground obstacles. There is no limit to the number of posts that can have additional blockouts up to 16" deep.

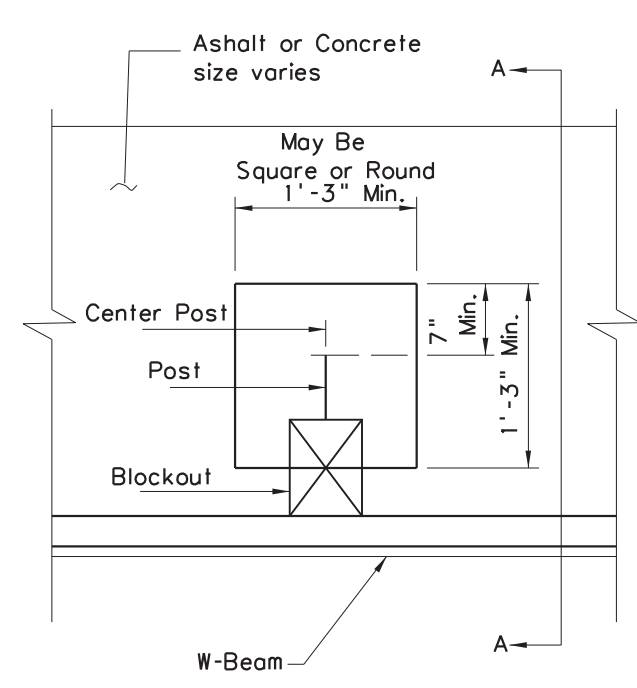

Steel Post Detail

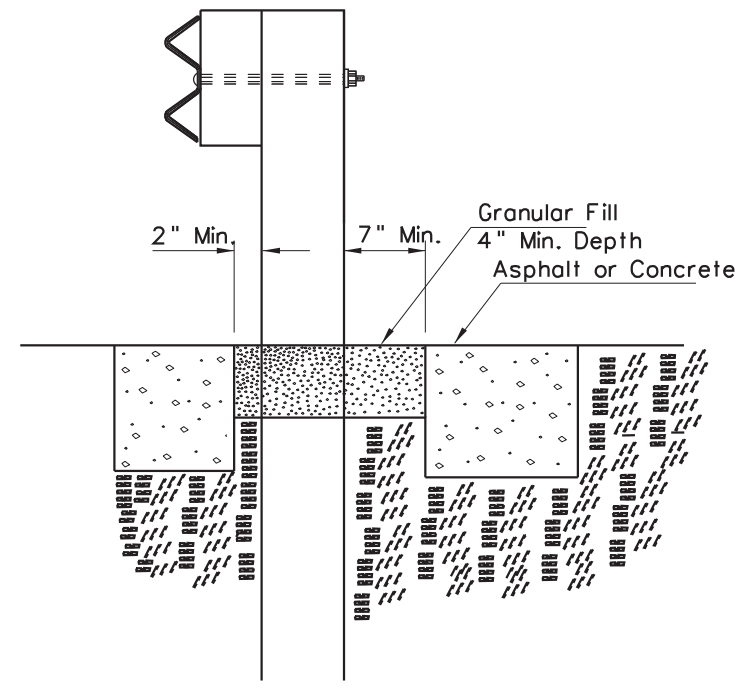

Section A-A

PAVING AROUND POSTS

Notes:
Unless otherwise noted no separate measurement or payment shall be made when details on this sheet are used. The cost associated with using these details shall be included in the appropriate guardrail pay item.

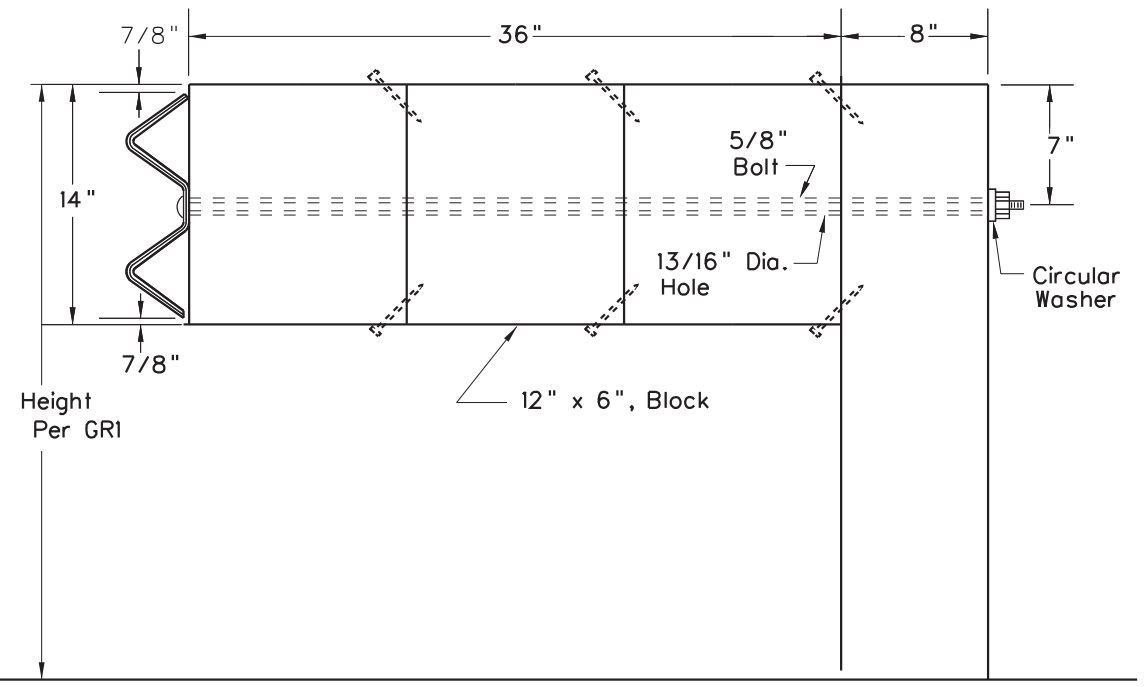

DETAIL FOR 36" BLOCKOUT DEPTH

Under special circumstances, such as avoiding obstacles that are not relocated, it is acceptable to install additional blockouts to obtain up to 36" depth for one or two consecutive posts in a section of guardrail.

Do not use 16" or 36" blockouts if it causes the post to be driven beyond shoulder hinge point or causes a fixed object to be within the deflection distance of the barrier.

- Reduce post spacing to 3'-1 1/2".
- Reduce post spacing to 1'-6 3/4".
- Double nest rail element.
- Any one stiffening method shall not exceed 25' in length.
- Any combination of stiffening methods shall not exceed 50' in length.

METHODS OF REDUCING W-BEAM DEFLECTION

WEST VIRGINIA DEPARTMENT OF TRANSPORTATION
DIVISION OF HIGHWAYS
STANDARD DETAIL

PREPARED 3-1-12
REVISION DATE

GUARDRAIL MODIFICATIONS

STANDARD SHEET GR15

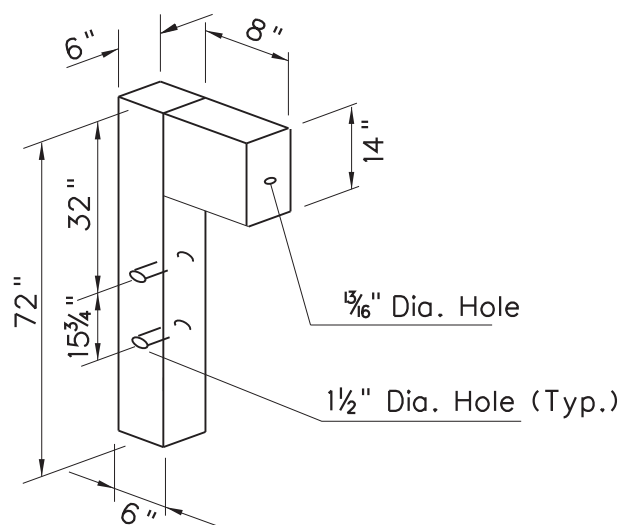

CRT WOODEN POST DETAIL

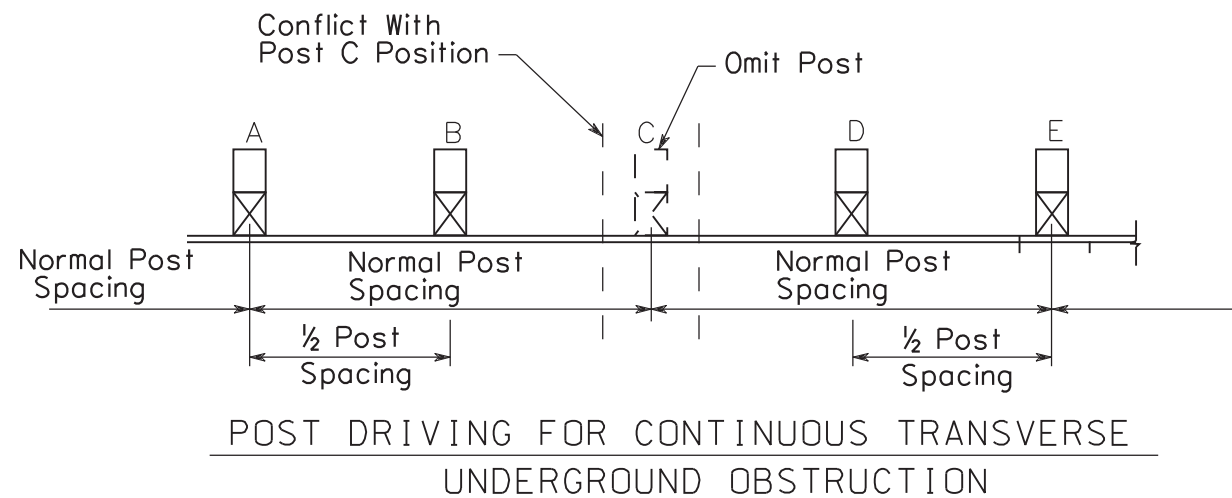

Notes:
 Unless otherwise noted
 no separate measurement
 or payment shall be made
 when details are used. The
 cost associated with these
 details shall be included in
 the appropriate guardrail pay item.

Details on this sheet
 to be used with Class I
 Guardrail only.

Methods of obstacle avoidance
 shown in Guardrail Modifications
 Sheet GR15 are preferred,
 if applicable.

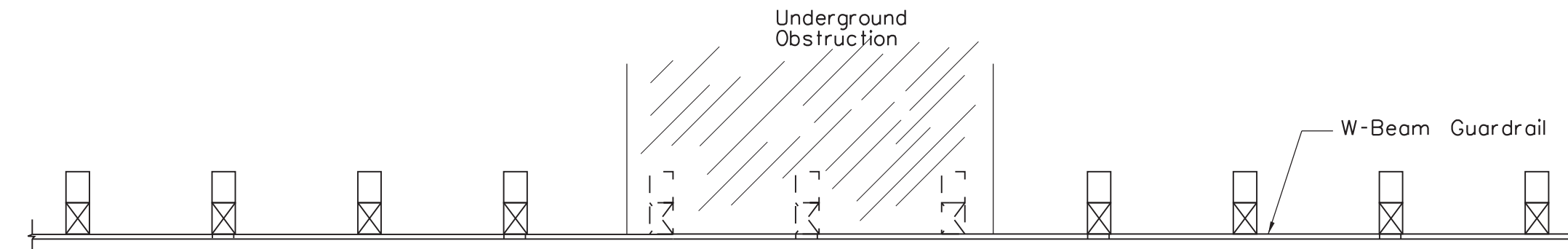

PLAN

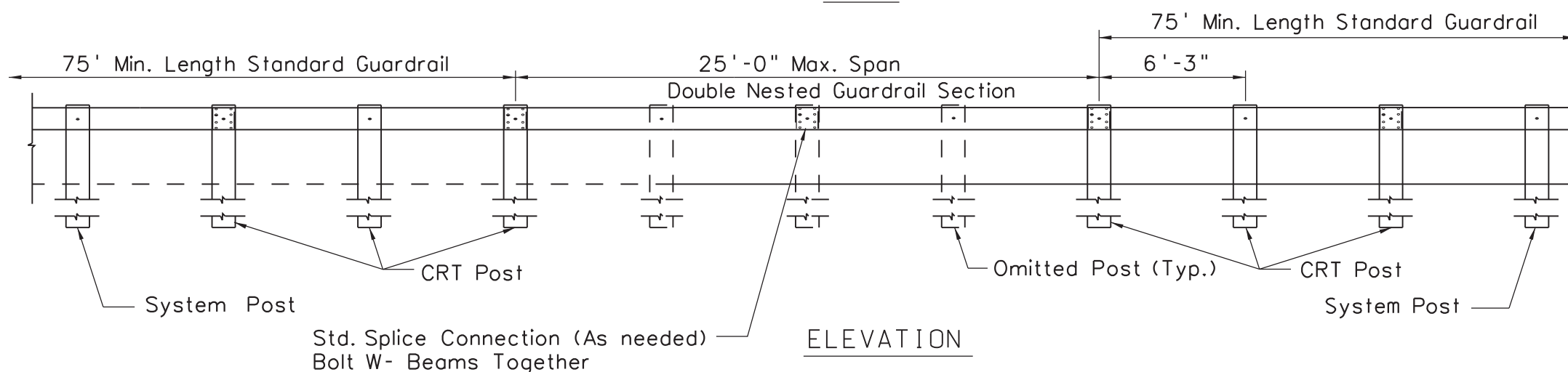

ELEVATION

OMITTING MULTIPLE POSTS FOR UNDERGROUND OBSTRUCTION

Only those posts conflicting with the obstacle shall be eliminated.
 A maximum of three posts may be eliminated within 25' span of
 W-Beam guardrail.

WEST VIRGINIA DEPARTMENT OF TRANSPORTATION
 DIVISION OF HIGHWAYS
 STANDARD DETAIL

PREPARED 3-1-12
 REVISION DATE

**GUARDRAIL MODIFICATION
 FOR UNDERGROUND
 OBSTRUCTIONS**

STANDARD SHEET GR16

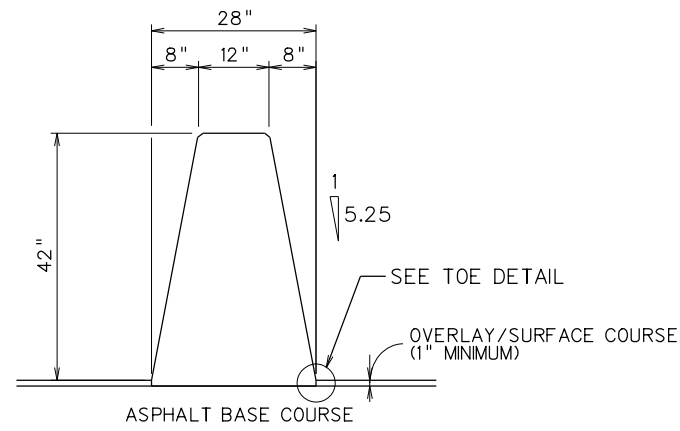

**TYPE X MEDIAN
SINGLE SLOPE CONCRETE BARRIER
(ASPHALT PAVEMENTS)**

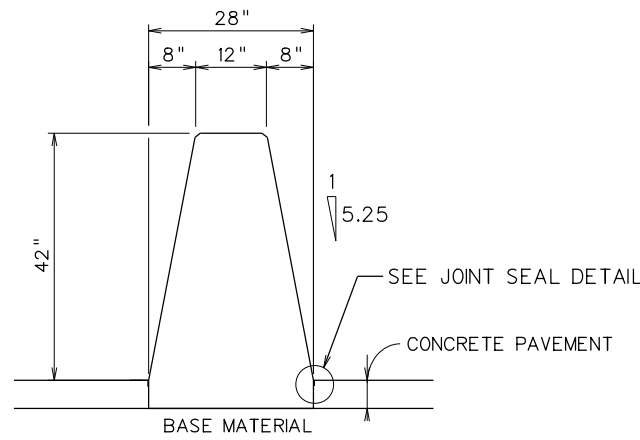

**TYPE X MEDIAN
SINGLE SLOPE CONCRETE BARRIER
(CONCRETE PAVEMENTS)**

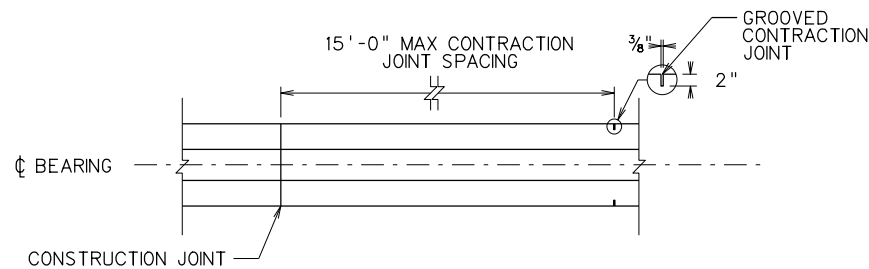

PLAN

JOINT LAYOUT

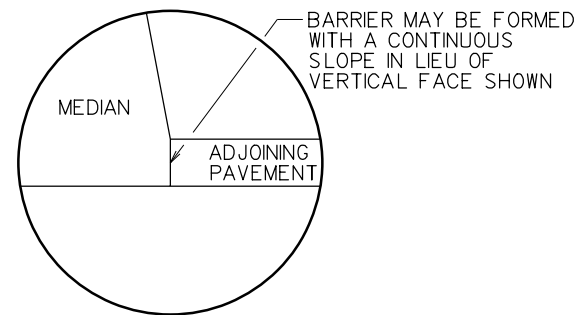

TOE DETAIL

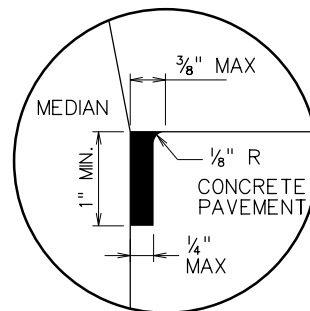

JOINT SEAL DETAIL

NOTES

CAST-IN-PLACE OR SLIP FORMED CONCRETE MEDIAN BARRIER SHALL BE CONSTRUCTED IN SECTIONS AS SHOWN HEREIN AND SHALL BE CONSTRUCTED IN ACCORDANCE WITH THE APPLICABLE PROVISIONS OF SECTION 610 OF THE SPECIFICATIONS.

CONCRETE SHALL MEET A MINIMUM DESIGN STRENGTH OF 4000 PSI, AND ANY APPLICABLE PROVISIONS OF SECTION 601, 501 OR 708 OF THE SPECIFICATIONS. REBAR MAY BE EITHER GRADE 40 OR 60.

MEDIAN BARRIER CONTRACTION JOINTS OVER EXISTING PAVEMENT CONTRACTION JOINTS SHALL BE SEPARATED BY OPEN JOINTS. MEDIAN JOINTS SHALL HAVE THE SAME WIDTH AS THE PAVEMENT JOINTS FOR THE FULL EXPOSED DEPTH OF THE MEDIAN.

AT ALL OTHER MEDIAN BARRIER CONTRACTION JOINTS A GROOVE 3/8" WIDE AND 2" DEEP, SHALL BE SAWED OR FORMED ACROSS THE TOP AND ALONG THE SIDES FOR THE ENTIRE DEPTH OF THE MEDIAN OR A FULL DEPTH BUTT JOINT SHALL BE FORMED. CONTRACTION JOINTS SHALL BE FORMED AT 15' INTERVALS ALONG THE LENGTH OF THE MEDIAN. THESE GROOVED OR BUTT JOINTS SHALL TRANSVERSELY ALIGN, WITHIN A PLUS OR MINUS ONE-FOOT TOLERANCE WITH THE JOINTS IN THE CONCRETE PAVEMENT.

EXPANSION JOINTS SHALL BE PLACED IN THE BARRIER MEDIAN AT STRUCTURES, OPPOSITE EXPANSION JOINTS IN THE CONCRETE PAVEMENT, OVER EXISTING EXPANSION JOINTS IN UNDERLYING CONCRETE PAVEMENT, AND AT OTHER LOCATIONS AS SHOWN ON THE PLANS OR DIRECTED BY THE ENGINEER. EXPANSION AT THESE JOINTS SHALL NOT REQUIRE END ANCHORAGE UNLESS INDICATED ON THE PLANS. AT EXPANSION JOINTS, MEDIAN BARRIER SECTIONS SHALL BE 3/4' APART AND THE OPENING FILLED, FOR THE ENTIRE DEPTH OF THE MEDIAN, WITH 3/4' PREFORMED JOINT FILLER WHICH COMPLIES WITH THE REQUIREMENTS OF SECTION 610 OF THE SPECIFICATIONS. THE FILLER SHALL BE RECESSED 1/4' IN FROM THE SIDES AND THE TOP OF THE MEDIAN AND THE COMPLETED JOINT SHALL RECEIVE NO FURTHER TREATMENT; E.G., SEALING WITH A WATERPROOF SEALER IS PROHIBITED.

THE FINISHED SURFACE OF THE MEDIAN BARRIER SHALL BE SMOOTH, DENSE, UNPITTED AND FREE FROM AIR BUBBLE POCKETS, DEPRESSIONS, AND HONEYCOMB. IF DEEMED NECESSARY BY THE ENGINEER, THE ABOVE MENTIONED FINISHED SURFACE WILL BE OBTAINED BY THE USE OF WATER AND A WOOD BLOCK OR CARBORUNDUM BRICK.

THE MEDIAN BARRIER SHALL BE ADEQUATELY TERMINATED AT EACH END, AS SHOWN OR SPECIFIED ELSEWHERE IN THE PROJECT PLANS.

DRAINAGE OPENINGS SHALL BE PROVIDED IN THE BARRIER MEDIANS WHERE INDICATED ON THE PLANS OR DIRECTED BY THE ENGINEER.

UNLESS OTHERWISE SPECIFIED, BI-DIRECTIONAL DELINEATORS, MEETING THE REQUIREMENTS OF 661 OF THE SPECIFICATIONS, SHALL BE SECURED AND MOUNTED ON SUITABLE SUPPORTS. DELINEATORS SHALL BE SPACED ALONG THE LENGTH OF THE MEDIAN BARRIER AS SHOWN AND SPECIFIED IN STANDARD DETAILS BOOK, VOLUME II.

TYPE OF SURFACE ADJACENT TO THE MEDIAN BARRIER SHALL BE SPECIFIED IN THE PLANS SHALL BE PAID FOR SEPARATELY.

THE COST OF CONCRETE MEDIAN, REBAR, PREFORMED JOINT FILLER, DELINEATORS AND DELINEATOR MOUNTINGS SHALL BE INCLUDED IN THE COST OF THE 'ITEM NUMBER 610006-010 MEDIAN, TYPE X'.

WEST VIRGINIA DEPARTMENT OF TRANSPORTATION
DIVISION OF HIGHWAYS
STANDARD DETAIL

PREPARED 6-17-21
REVISION DATE

MEDIAN BARRIER TYPE X
STANDARD DETAIL

(SHEET 1 OF 2)
STANDARD SHEET GR18

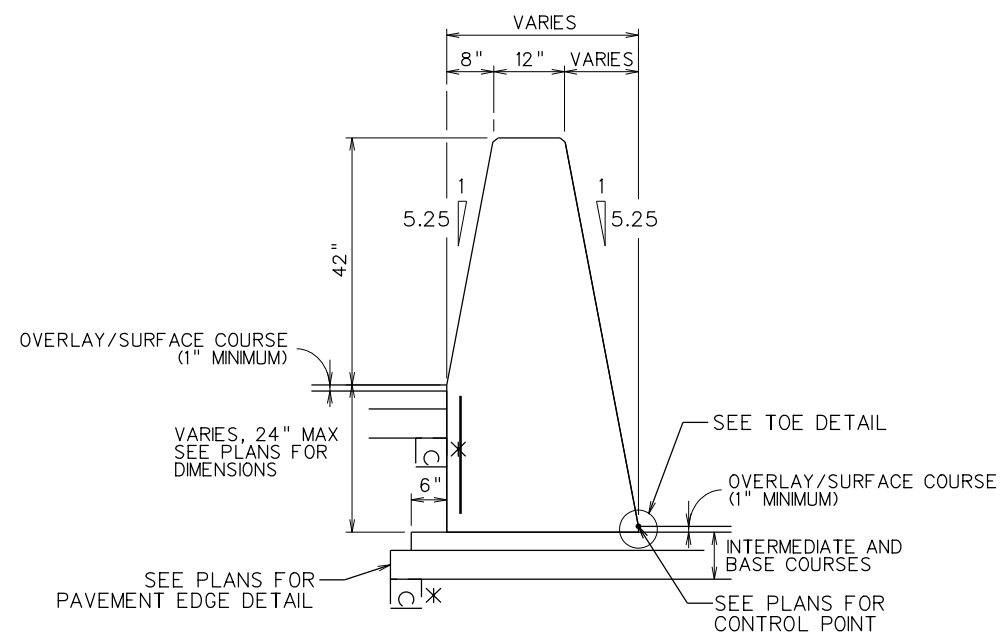

TYPE X MEDIAN MODIFIED BIFURCATED SINGLE SLOPE CONCRETE BARRIER (ASPHALT PAVEMENTS)

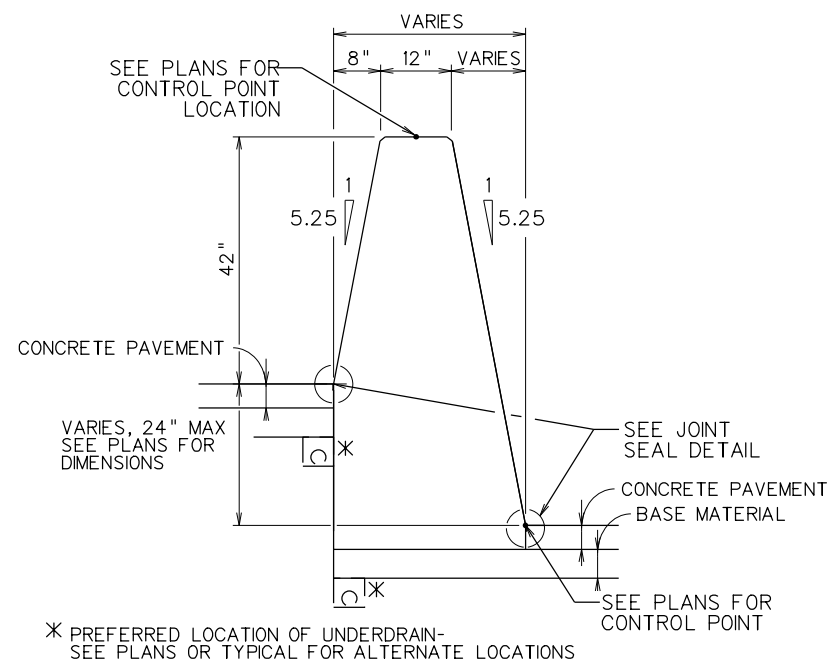

TYPE X MEDIAN MODIFIED BIFURCATED SINGLE SLOPE CONCRETE BARRIER (CONCRETE PAVEMENTS)

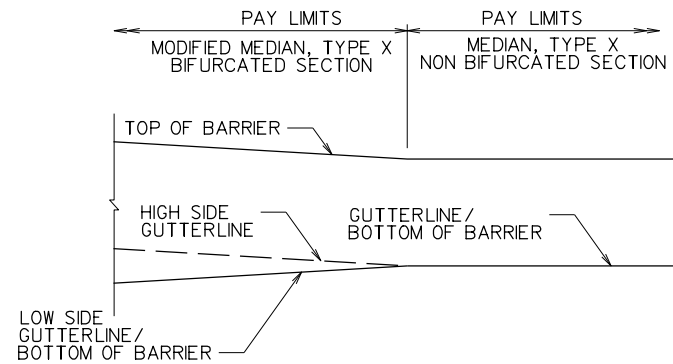

PAY LIMIT DETAIL SIDE VIEW

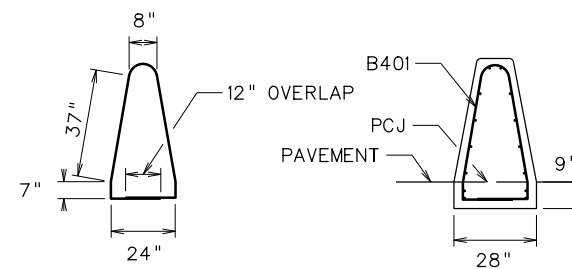

(TOTAL LENGTH = 10'-10")

B401 BEND DIAGRAM

SECTION

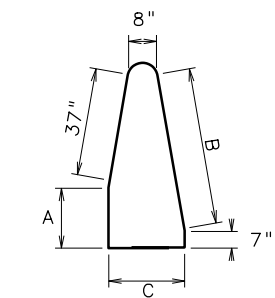

(MIN. LAP SPLICE = 3'-3")

B401 BEND DIAGRAM BIFURCATED

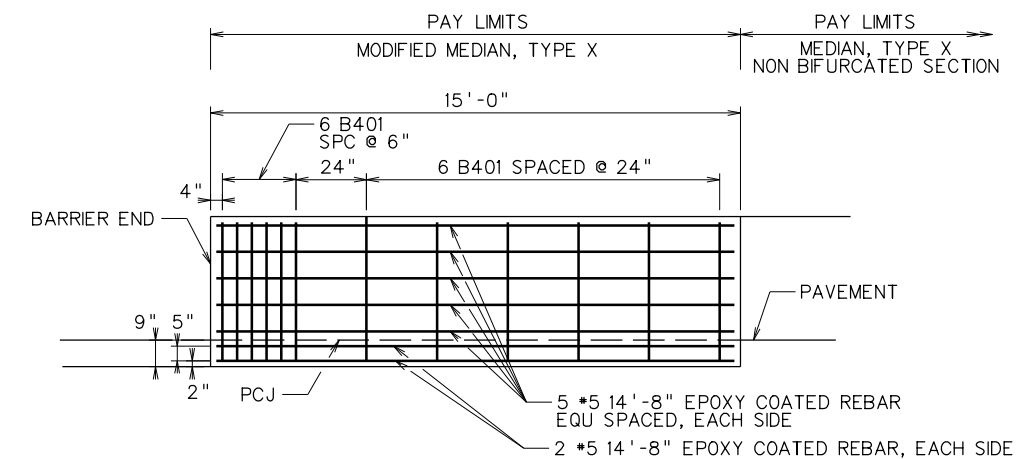

ELEVATION

REINFORCED END ANCHORAGE ARE REQUIRED AT THE ENDS OF CONCRETE BARRIER RUNS. END ANCHORAGE IS ALSO REQUIRED WHEN EXPANSION JOINT SPACING EXCEEDS 800'. AT THESE EXPANSION JOINTS, CONSTRUCT END ANCHORAGE ON BOTH SIDES OF JOINT WITH A 2' JOINT. MAXIMUM EXPANSION JOINT SPACING SHALL BE 800'. THIS DETAIL SHALL NOT BE USED AT CONSTRUCTION JOINTS OR OTHER EXPANSION JOINT LOCATIONS. DIMENSIONS A, B AND C SHALL BE SHOWN IN THE PLANS.

COST OF REBAR AND FILLER MATERIAL SHALL BE INCLUDED IN THE UNIT BID PRICE OF THE 'ITEM NUMBER 610006-100 MODIFIED MEDIAN, TYPE X'.

MODIFIED MEDIAN, TYPE X CONCRETE BARRIER END ANCHORAGE

WEST VIRGINIA DEPARTMENT OF TRANSPORTATION
DIVISION OF HIGHWAYS
STANDARD DETAIL

PREPARED 6-17-21
REVISION DATE

MEDIAN BARRIER TYPE X
STANDARD DETAIL

(SHEET 2 OF 2)
STANDARD SHEET GR18

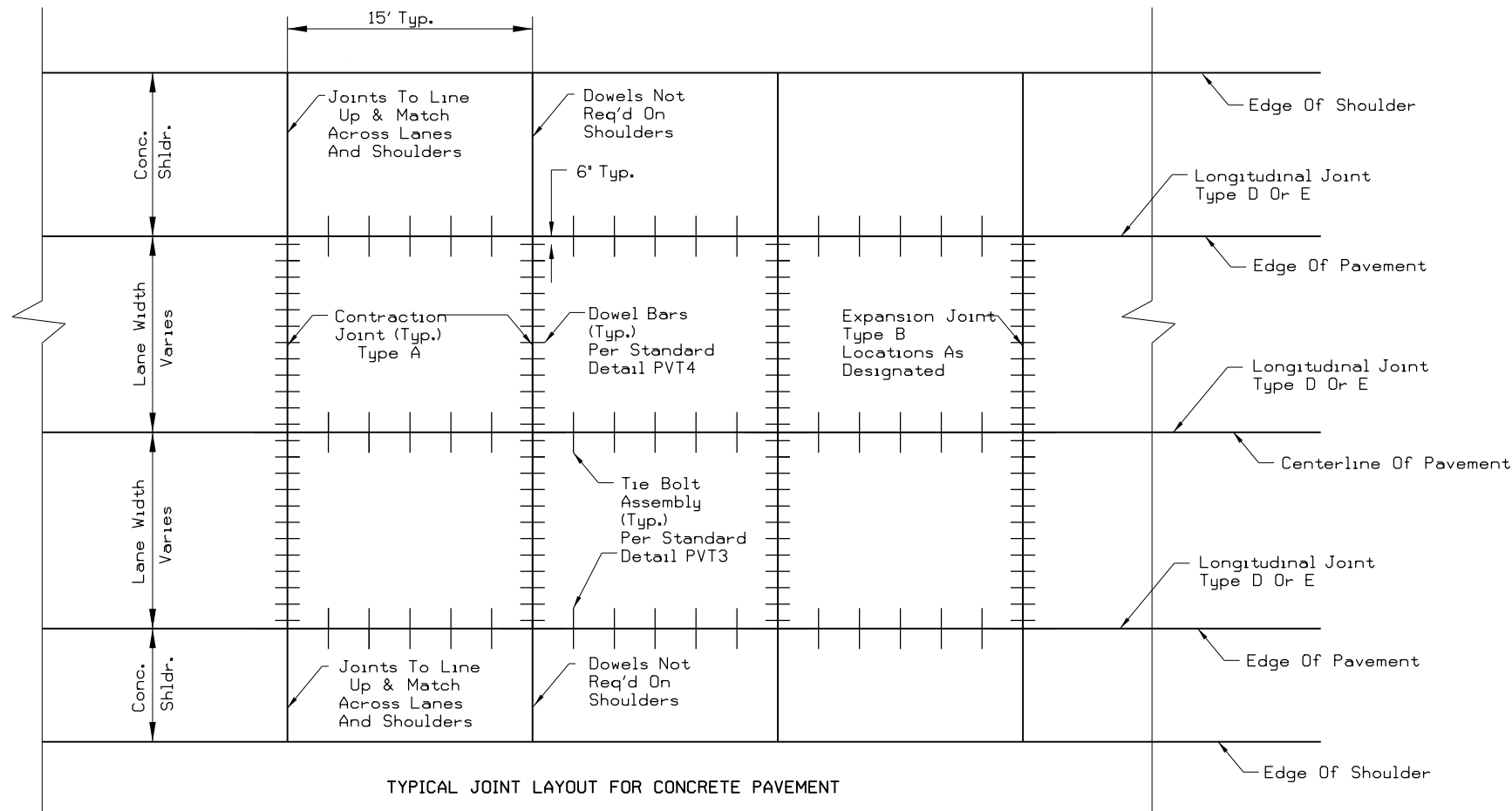

TYPICAL JOINT LAYOUT FOR CONCRETE PAVEMENT

NOTES

For additional details and requirements concerning dowel bars and dowel baskets for Type A & B Joints, see Standard Sheet PVT4.

Type D Longitudinal Joint may be used as an alternate to Type E Longitudinal Joint for lanes or shoulders that are full width construction.

For additional details and requirements concerning Types E Joints, see Standard Sheet PVT3, Longitudinal Tie Bolt Assembly.

The Contractor shall submit for approval a Joint Layout Plan for all intersections on the project in general accordance with the 'Street Jointing Criteria: Ten Rules Practice' as suggested by the Portland Cement Association (PCA), Skokie, Ill. Illinois; the American Concrete Pavement Association's Joint Layout Guidelines; and the West Virginia Division Of Highways' Standard Specifications.

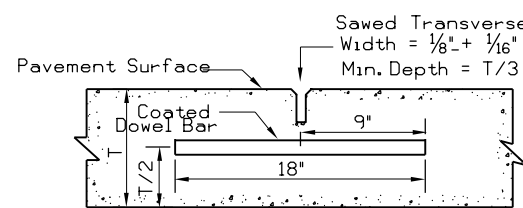

CONTRACTION JOINT
TYPE A

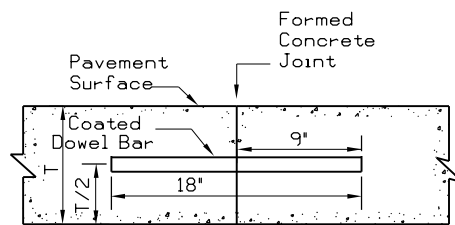

CONSTRUCTION JOINT
TYPE A

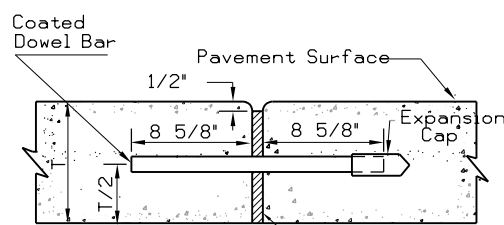

EXPANSION JOINT
TYPE B

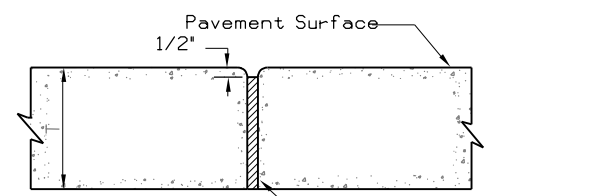

EXPANSION JOINT
(Without Dowel Bars)
TYPE C

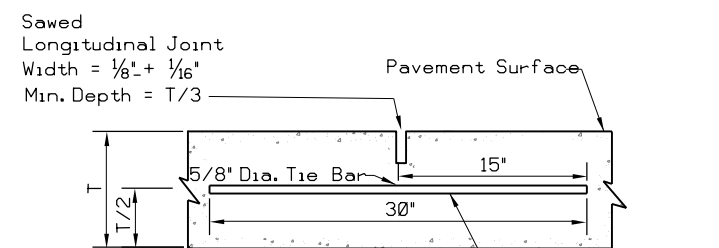

LONGITUDINAL JOINT
(Full-Width Construction)
TYPE D

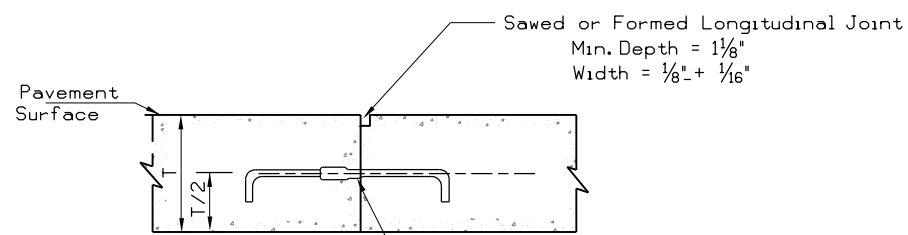

LONGITUDINAL JOINT
(Lane-At-A-Time Construction)
TYPE E

WEST VIRGINIA DEPARTMENT OF TRANSPORTATION
DIVISION OF HIGHWAYS
STANDARD DETAIL

PREPARED 7-1-99
REVISION DATE
11-22-2010

CONCRETE PAVEMENT
JOINT LAYOUT
AND TYPES

STANDARD SHEET PVT1

NOTES

TYPE E JOINT

The Modified Type E Joint as detailed is not to be used in lieu of the Longitudinal Joint as detailed on Standard Sheet PVT1. It is to be used when tying new concrete pavement to existing pavement (pavement placed prior to the project in which new pavement is placed) unless otherwise specified. The expansion anchor and the 5/8" hook bolt are to meet the requirements of Section 709.7 of the Specifications.

Expansion Anchor / Hook Bolt assemblies are to be placed on 30" centers unless otherwise specified. All costs involved in the Modified Type E joint is to be included in the unit bid for the new concrete pavement.

All tie bars and J or Hook Bolt assemblies shall be epoxy coated in accordance with Section 709.1 of the Standard Specifications.

TYPE H JOINT

The Type H Joint is to be used for connecting portland cement concrete pavement to asphalt pavement. The standard coated dowel bars are to meet the applicable requirements of Standard Sheet PVT4.

RUMBLE STRIP

Rumble strips shall be sawed or milled unless otherwise indicated. The top of the rumble strips will be no higher than the top surface of the pavement. Any faulty or incorrectly installed rumble strips will be corrected by the contractor at his expense.

Rumble strips shall not be installed on bridge decks, loop detector saw-cut locations, structures, approach slabs or in other areas identified by the Engineer.

When called for on plans, rumble strip depth shall be reduced to 3/8". The center to center spacing of each individual cut shall remain as 12". Due to changed radius, other longitudinal (direction of traffic) dimensions will vary. This variance is acceptable.

Remove debris from areas disturbed by milling operation before opening roadway to traffic.

Edgeline rumble strips shall have a gap per detail. This gap will be eliminated for roadways that prohibit bicycles and on the inside shoulders of divided highways.

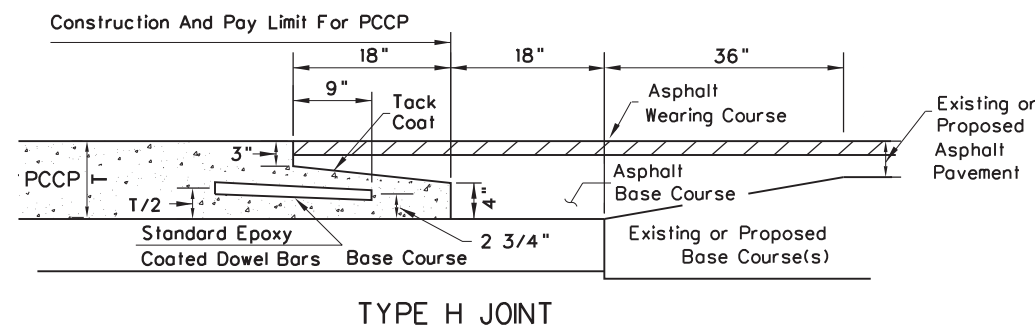
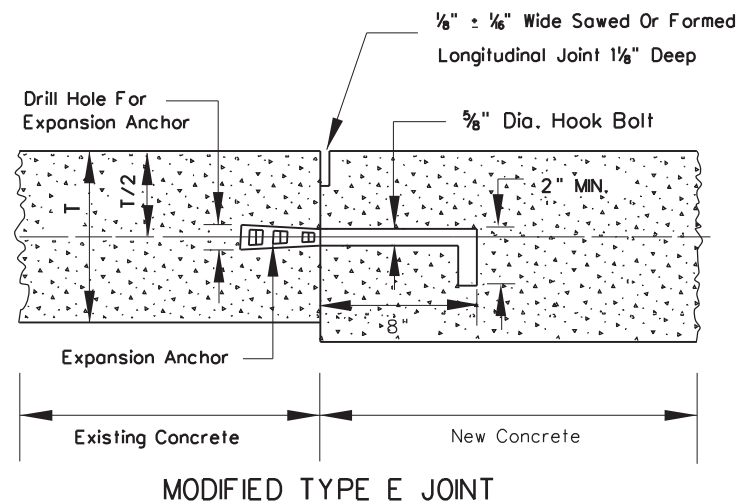
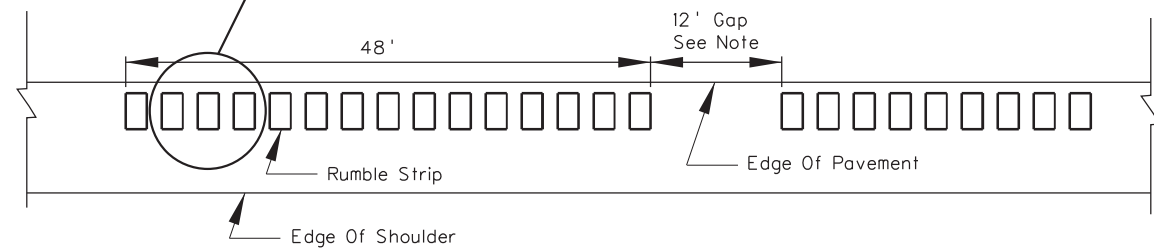
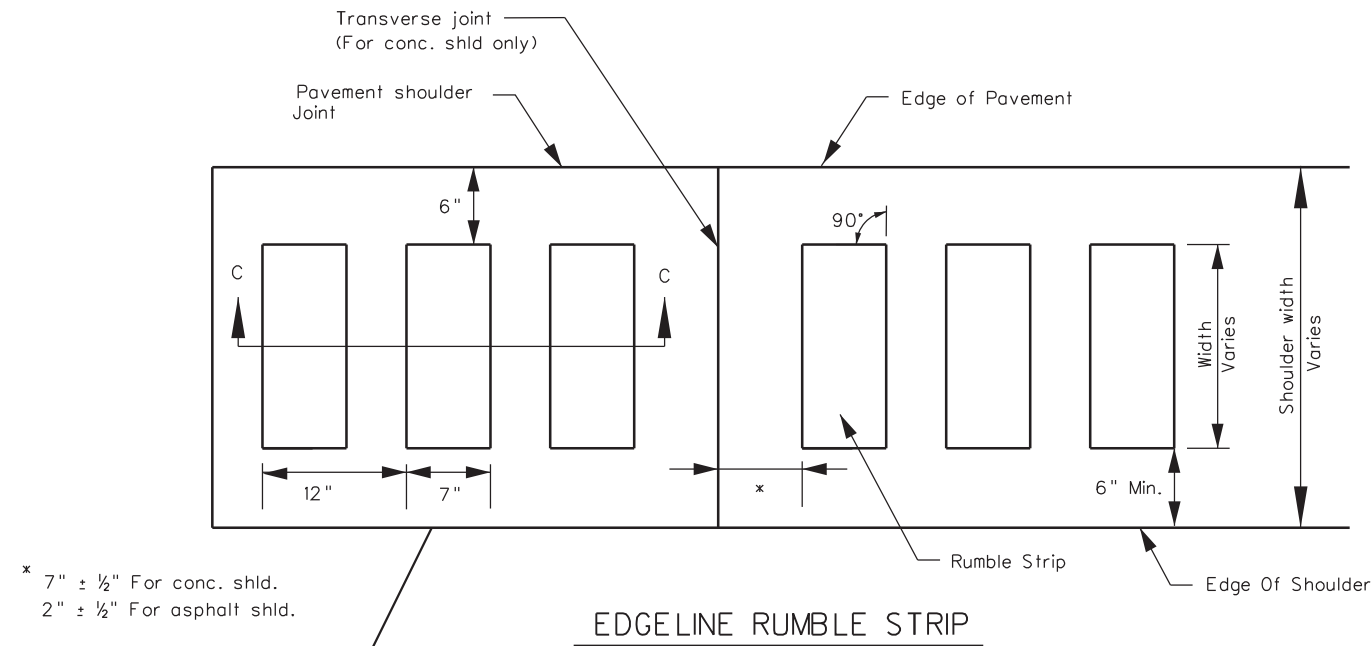
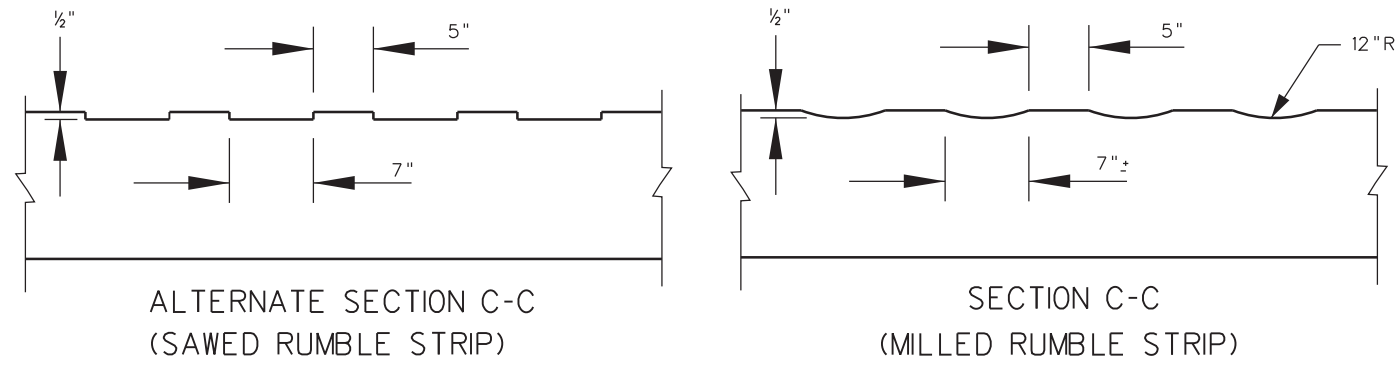

Edgeline Rumble Strip Widths	
Shoulder Width	Rumble Strip Width
4' or greater	16"
Less than 4'	12"

6" Min. at Edge of Shoulder Shall Govern

WEST VIRGINIA DEPARTMENT OF TRANSPORTATION
DIVISION OF HIGHWAYS
STANDARD DETAIL

PREPARED 7-1-99
REVISION DATE
11-22-2010

**RUMBLE STRIPS,
TYPE H JOINT,
MODIFIED E JOINT**

STANDARD SHEET PVT2

TYPICAL HOOK BOLT DETAILS
TYPE E JOINTS

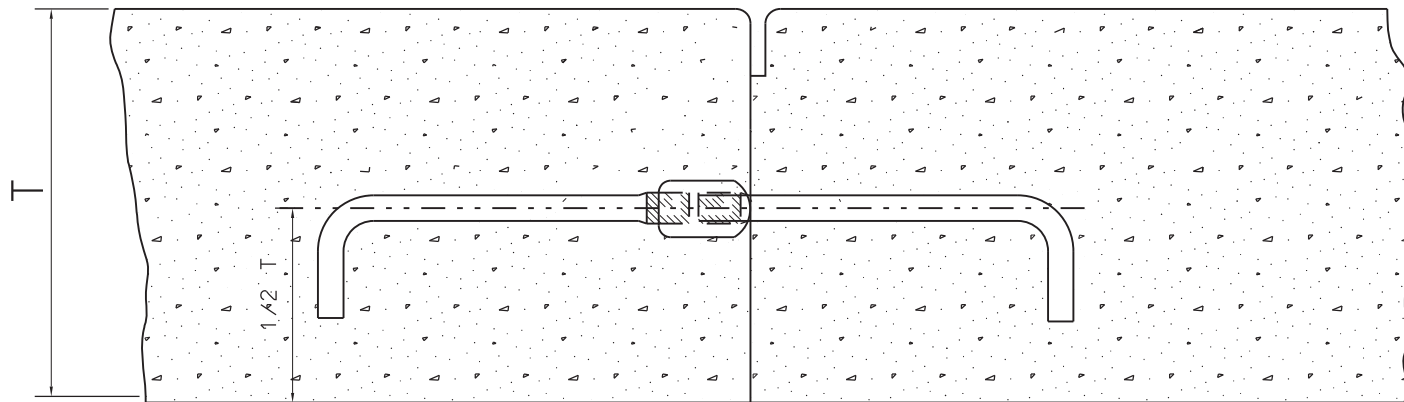

PAVEMENT SECTION

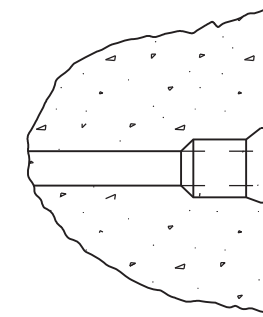

TRAPEZOIDAL KEY
(J Bolt Shown)

TYPICAL J BOLT DETAILS
TYPE E JOINTS

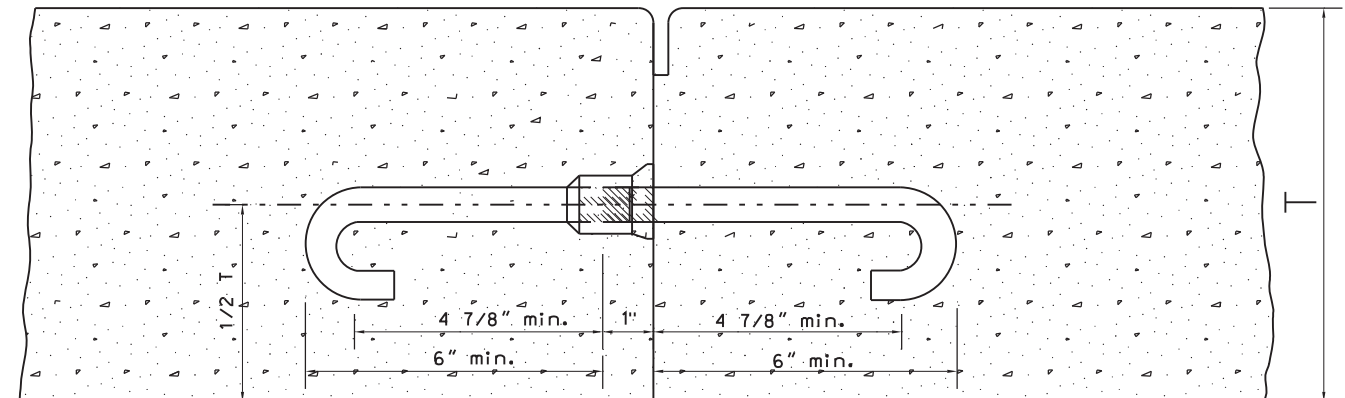

PAVEMENT SECTION

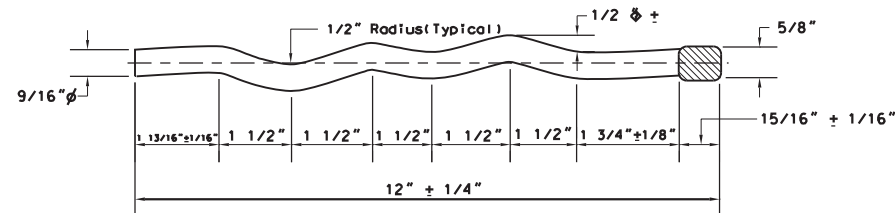

ALTERNATE HOOK BOLT

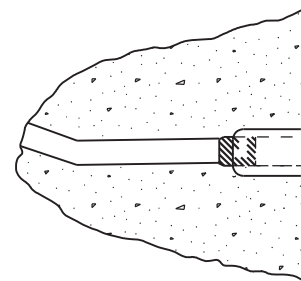

ALTERNATE (HALF-ROUND) KEY
(Alternate Hook Bolt Shown)

NOTES

- Tie bolts shall meet the requirements of Section 709.7 of the Specifications.
- Tie bolts shall be placed on 30" centers(max.)
- Tie bolts shall be placed 15" from each end of form.
- Metal channel shall run the full length of forms.
- 5/8" diameter tie bars; 30" long, placed longitudinally on 30" centers (max.), and centered across the joint or pavement edge; may be used in place of the bolt assemblies.
- The longitudinal tie bolt assembly for slip-form paving shall consist of one sleeve nut, one 8" long hook bolt or J bolt, and 12" long alternate hook bolt. As an initial step in installing this assembly, the 12" long alternate hook bolt, with sleeve nut attached, shall be positioned in its proper location in the pavement by appropriate slip-form paving equipment.
- Typical tie bolt assemblies are shown herein. Minor variations in details and dimensional tolerances are permitted; however, minimum values specified herein shall be complied with.
- All tie bars and Tie Bolt Assemblies shall be epoxy coated in accordance with section 709.1 of the Standard Specifications.

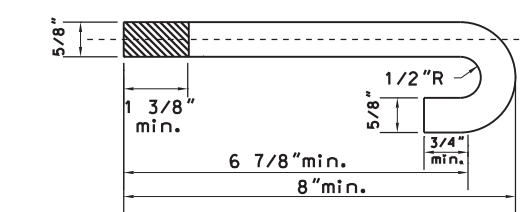
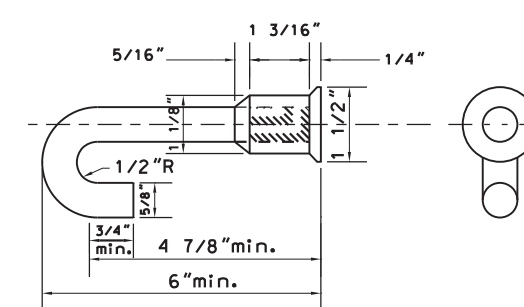
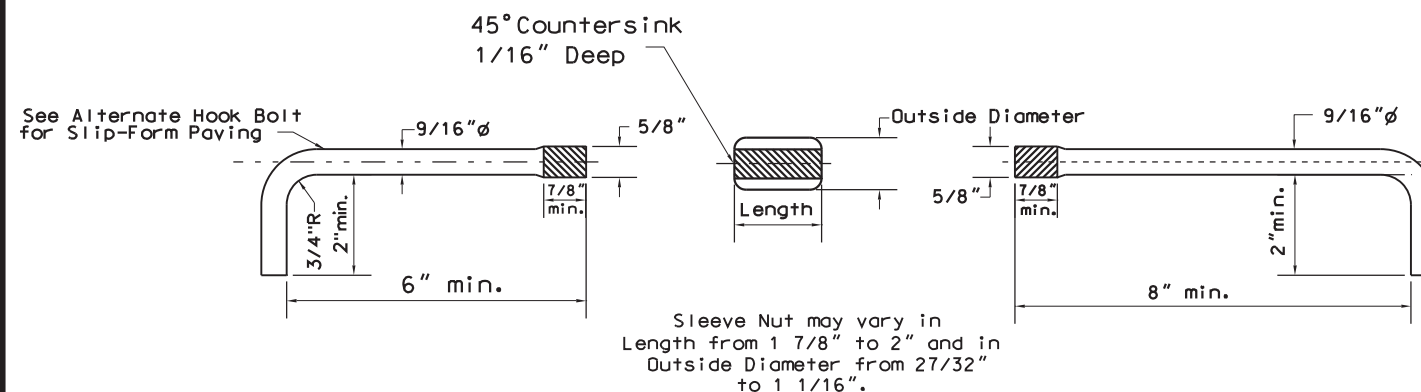
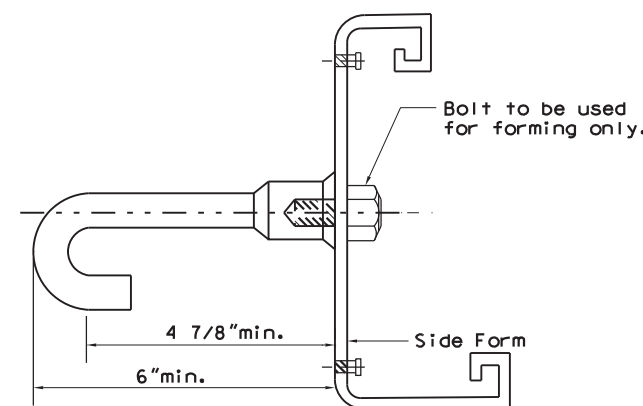
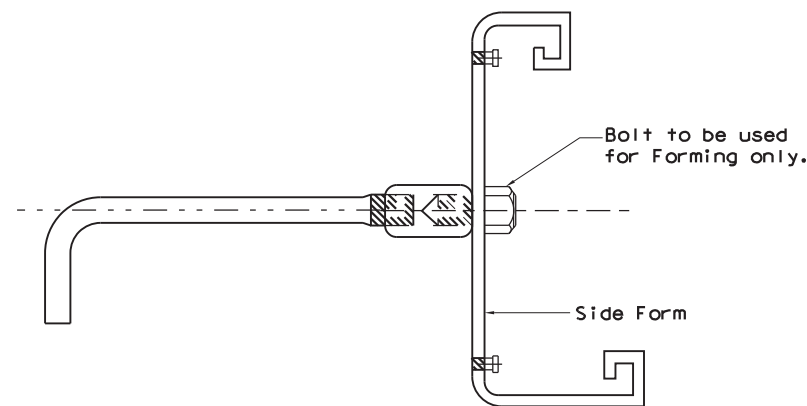

WEST VIRGINIA DEPARTMENT OF TRANSPORTATION
DIVISION OF HIGHWAYS
STANDARD DETAIL

LONGITUDINAL
TIE BOLT
ASSEMBLY

STANDARD SHEET PVT3

PREPARED 7-1-99
REVISION DATE
11-24-2010

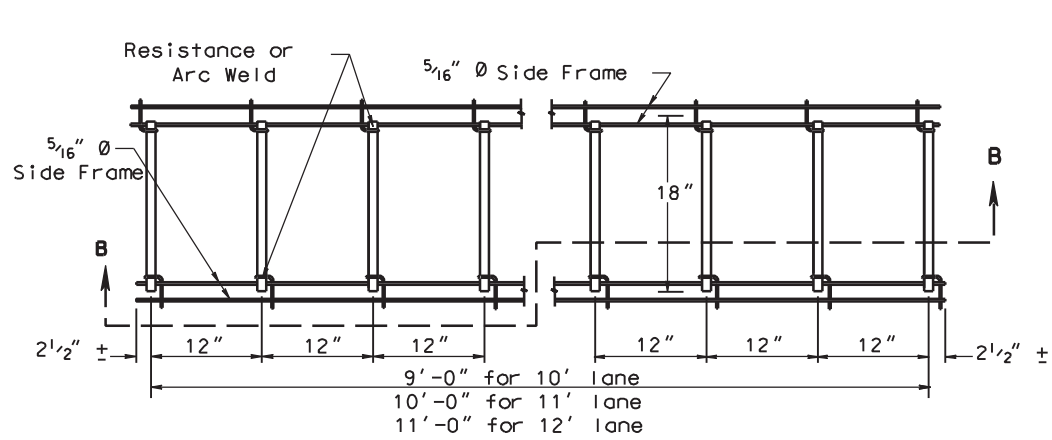

PLAN OF DOWEL UNIT FOR CONTRACTION JOINT

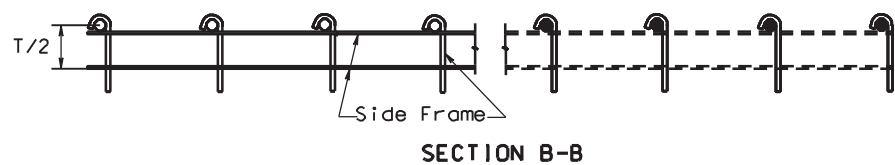

SECTION B-B

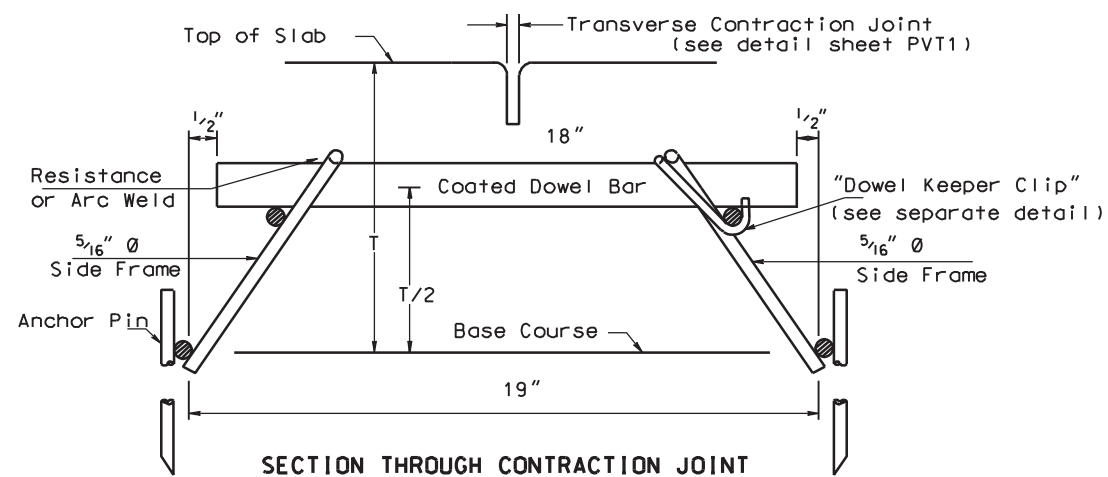

SECTION THROUGH CONTRACTION JOINT

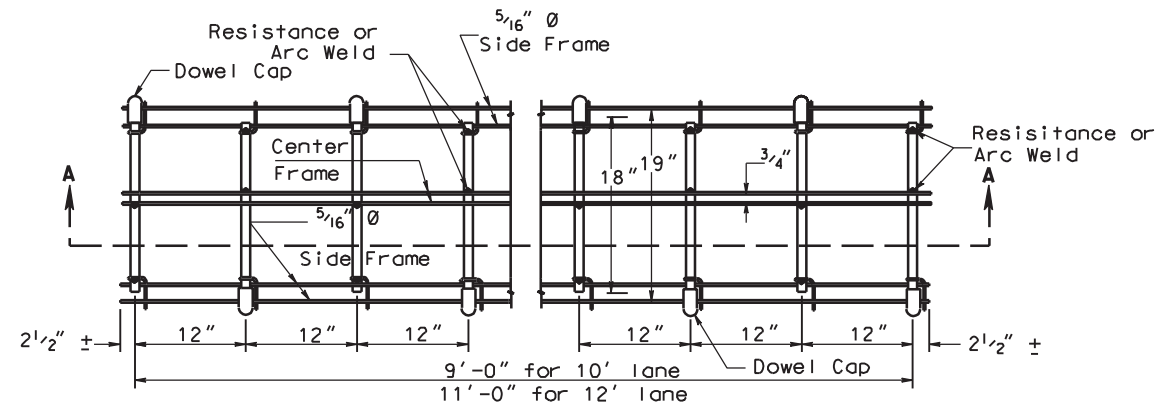

PLAN OF DOWEL UNIT FOR EXPANSION JOINT
(JOINT FILLER NOT SHOWN)

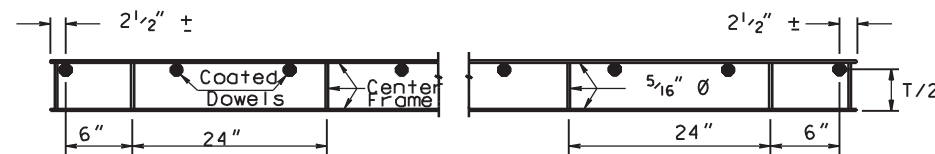

SECTION A-A

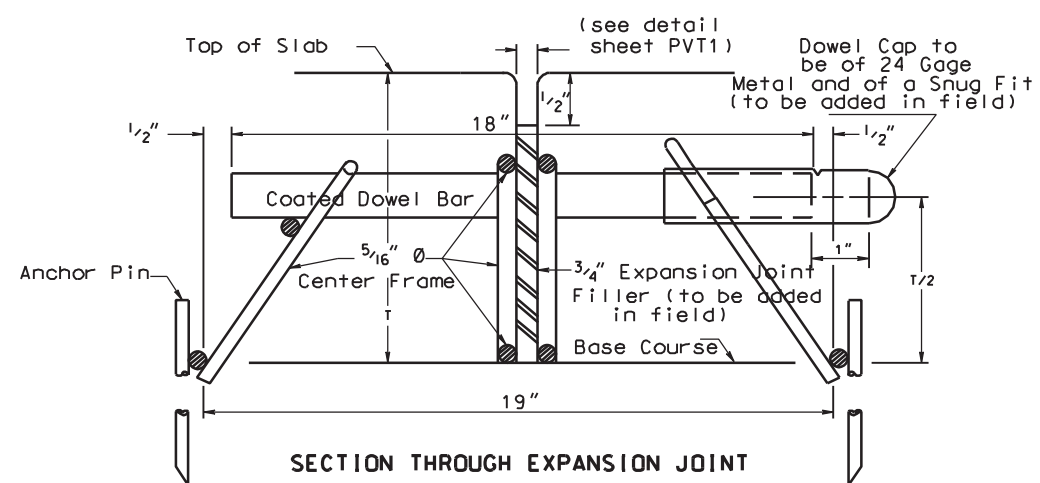

SECTION THROUGH EXPANSION JOINT

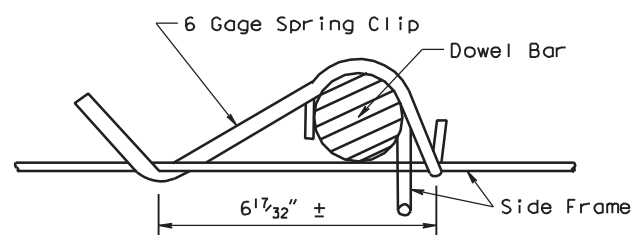

DOWEL KEEPER CLIP
(4 TO EACH CONTRACTION JOINT ASSEMBLY)

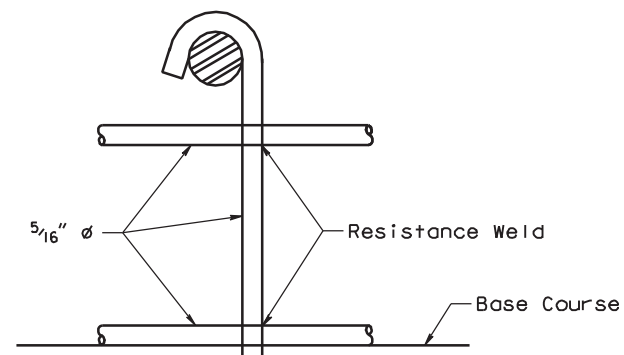

SIDE FRAME DETAIL

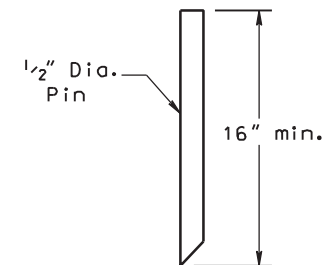

ANCHOR PIN

NOTES

All dowel bars shall have a Department approved coating and shall meet the requirements of Section 709.15 of the Specifications. Dowel bar uncoated diameter to be $\frac{1}{8}$ of the pavement thickness with minimum diameter of $1\frac{1}{4}$ ". Dowel bars to be 18" long and spaced on 1' c.c.

The units are to be shop assembled as to dowels, side frames, and center frames, and shipped nested.

The units are to be fabricated to fit the crown of the base course.

Wire used in the expansion and contraction joint load transfer units shall have a minimum ultimate tensile strength of 50,000 P.S.I.

The expansion joint load transfer unit detailed herein shall be used at specially designated locations only.

Anchor pins are to be $\frac{1}{2}$ " round bars and 16" minimum length to hold the unit rigidly in place. A minimum of 8 pins per unit shall be used.

The units as detailed are shown as examples only. Initial approval of load transfer units shall be by submission of shop drawings. Approval will be valid until the standard drawing is revised or the supplier changes his design. All notes as shown above are to apply.

WEST VIRGINIA DEPARTMENT OF TRANSPORTATION
DIVISION OF HIGHWAYS
STANDARD DETAIL

PREPARED 7-1-99

REVISION DATE

LOAD TRANSFER UNIT

STANDARD SHEET PVT4

* or thickness of pavement, when abutting concrete pavement.
 ** Does not apply, when abutting concrete pavement. Instead a longitudinal joint with tie bars or tie bolt assemblies shall be constructed at this location. joint with tie bars or tie bolt assemblies shall be constructed at this location.

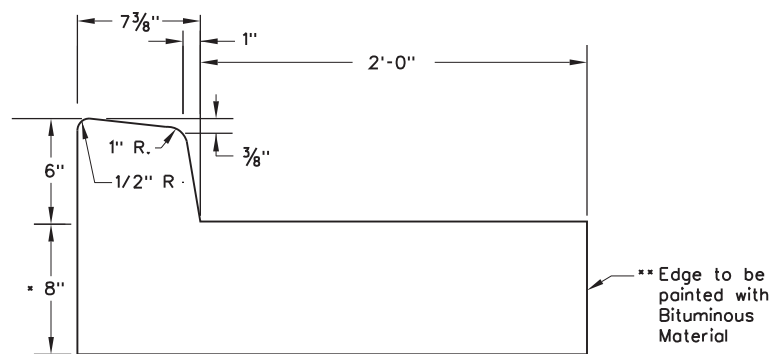

COMBINATION CONCRETE CURB AND GUTTER TYPE I

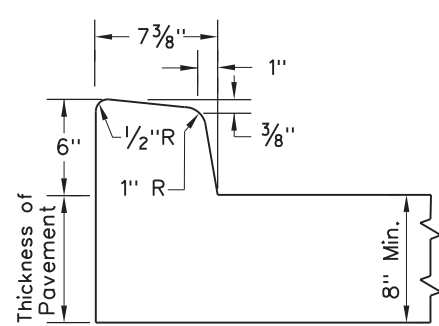

INTEGRAL CONCRETE CURBING TYPE I

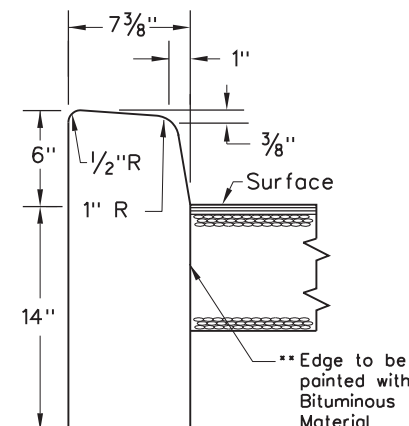

PLAIN CONCRETE CURBING TYPE I

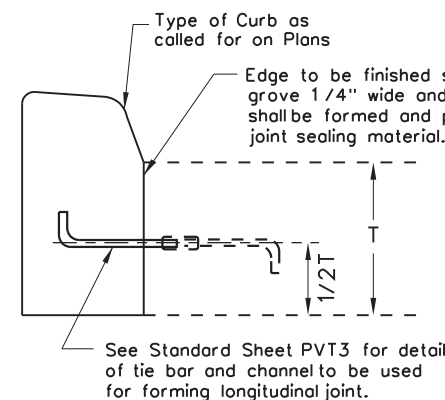

DETAILS SHOWING PLACING OF CONCRETE CURB BY SEPARATE METHODS

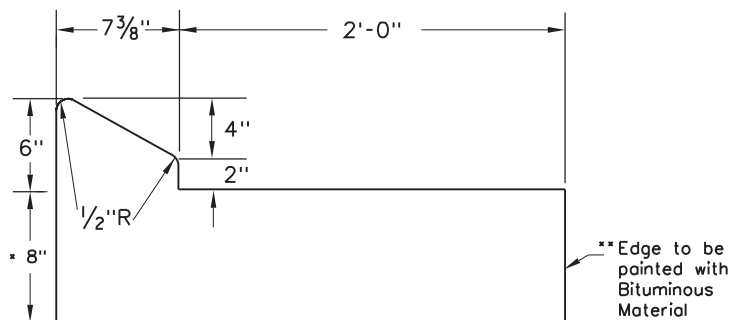
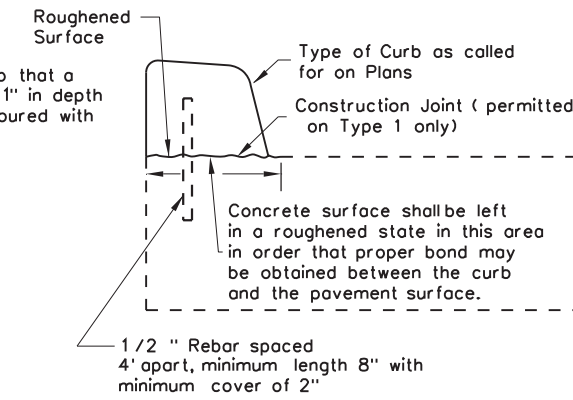

COMBINATION CONCRETE CURB AND GUTTER TYPE II

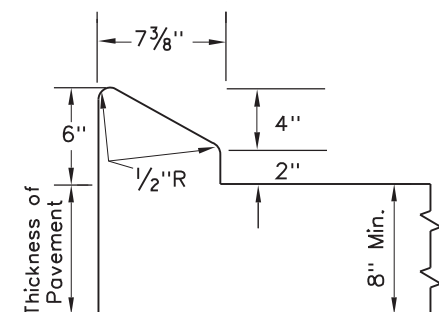

INTEGRAL CONCRETE CURBING TYPE II

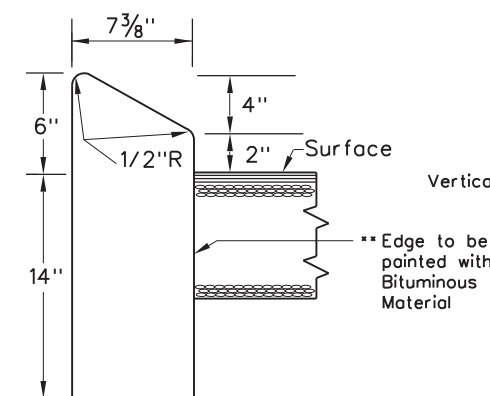

PLAIN CONCRETE CURBING TYPE II

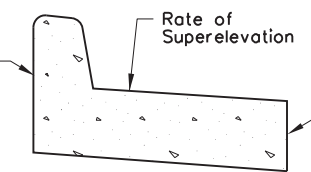

SKETCH SHOWING METHOD OF PLACING CURB ON HIGH SIDE OF SUPERELEVATED SECTION

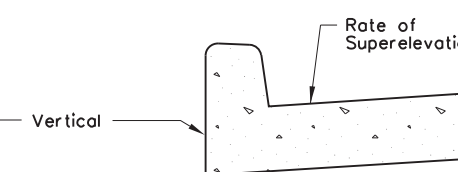

SKETCH SHOWING METHOD OF PLACING CURB ON LOW SIDE OF SUPERELEVATED SECTION

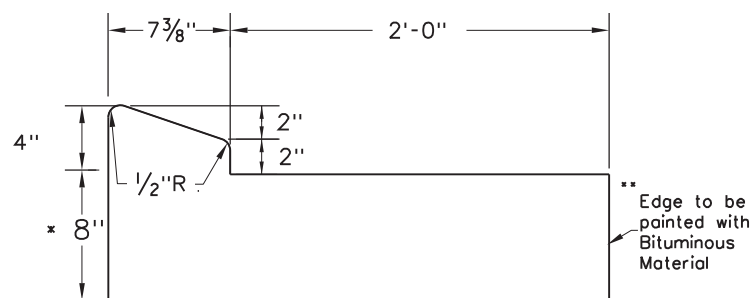

COMBINATION CONCRETE CURB AND GUTTER TYPE III

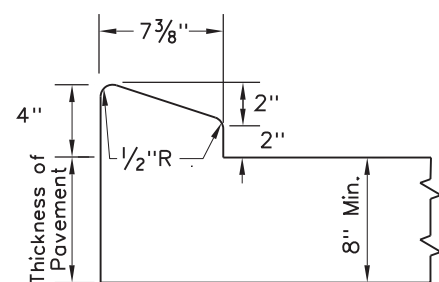

INTEGRAL CONCRETE CURBING TYPE III

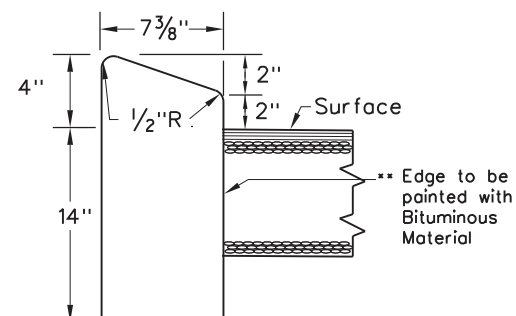

PLAIN CONCRETE CURBING TYPE III

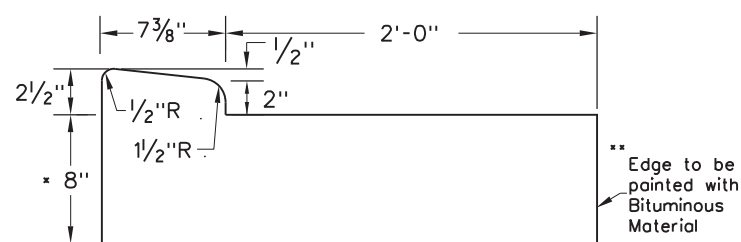

COMBINATION CONCRETE CURB AND GUTTER TYPE IV

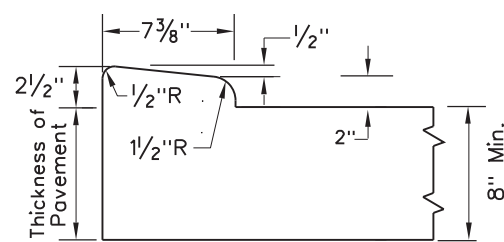

INTEGRAL CONCRETE CURBING TYPE IV

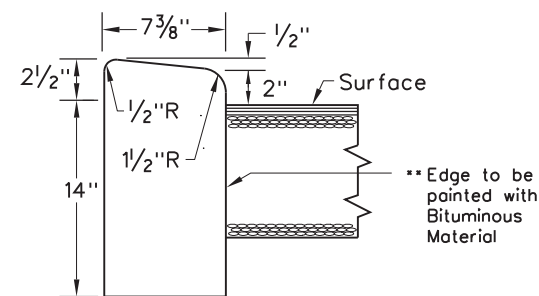

PLAIN CONCRETE CURBING TYPE IV

NOTES

For all Concrete Curbing, the face of the curbing shall be offset a minimum of two feet from the edge of traffic lane, unless otherwise shown on the Plans.

Construction of Concrete Curbing shall be by the "Separate Method" when sawed joints are constructed in the pavement.

All curb joints shall be made by acceptable forming methods.

For Combination Concrete Curbs And Gutters, the slope of the 2'-0" wide concrete gutter shall conform to the pavement slope or as otherwise specified on the Plans.

WEST VIRGINIA DEPARTMENT OF TRANSPORTATION
 DIVISION OF HIGHWAYS
 STANDARD DETAIL

PREPARED 7-1-99
 REVISION DATE
 3-6-2012

CONCRETE CURBING
 AND
 SIDEWALK
 (SHEET 1 of 2)

STANDARD SHEET PVT6

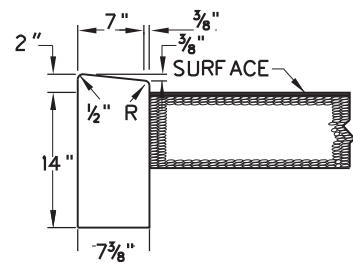

END ELEVATION

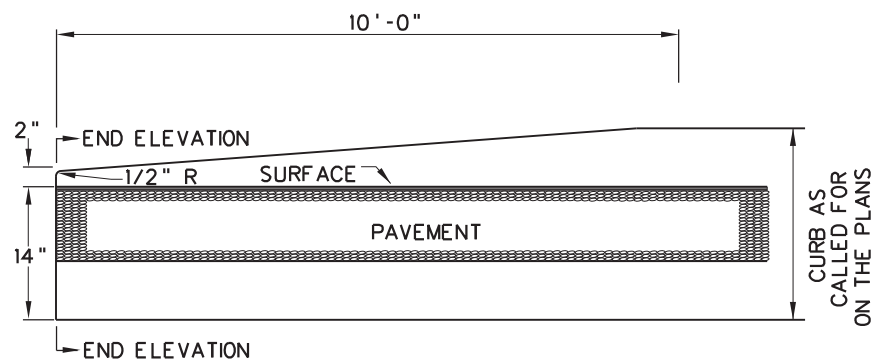

ELEVATION

STANDARD CURB TAPER
CLASS I

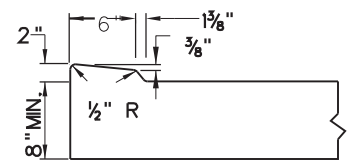

END ELEVATION

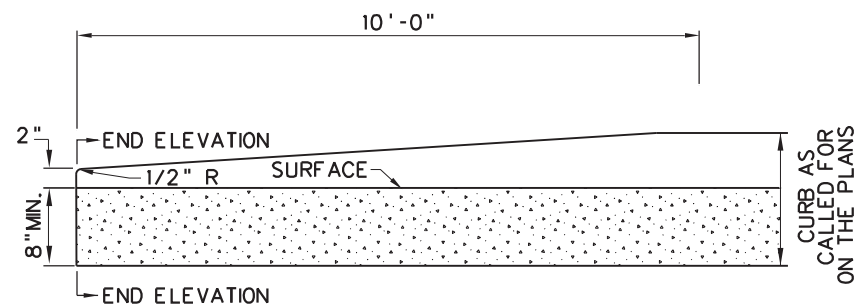

ELEVATION

STANDARD CURB TAPER
CLASS II

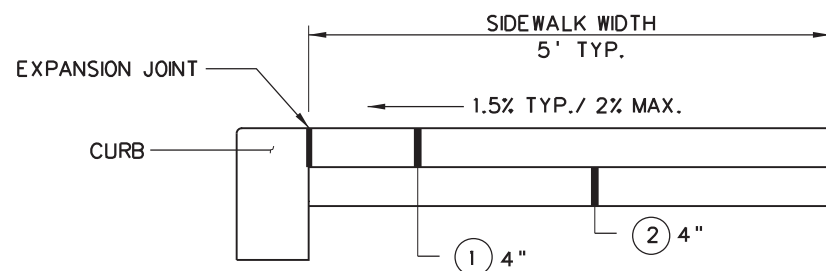

SIDEWALK TYPICAL

- ① CONCRETE SIDEWALK ITEM 609001 S.Y.
- ② BED COURSE MATERIAL ITEM 609002 C.Y.

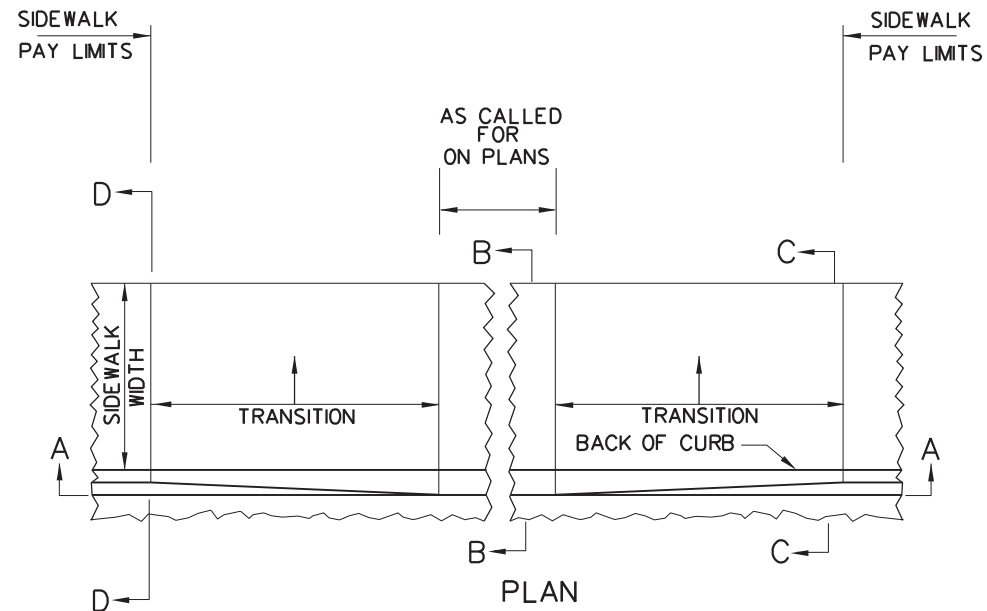

PLAN

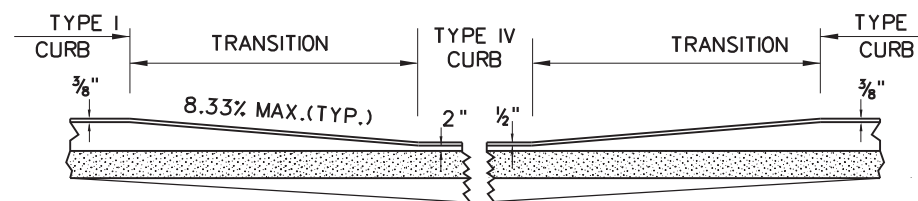

SECTION A-A

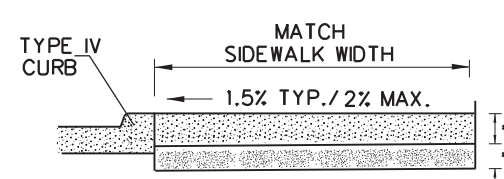

SECTION B-B

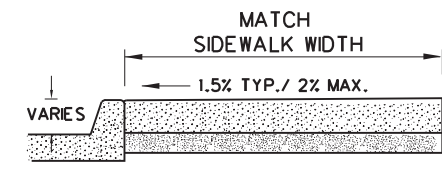

SECTION C-C

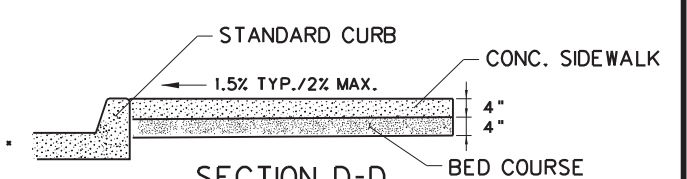

SECTION D-D

SIDEWALK AND CURB
TREATMENT AT DRIVEWAYS

- 6" PCC PAVEMENT OR PER DRIVEWAY TYP.
- 6" AGGREGATE BASE, 4" FREE DRAINING BASE OR PER DRIVEWAY TYP.

NOTES

THE STANDARD CURB TAPER, CLASS I, SHALL BE USED AT THE ENDS OF ALL PLAIN CONCRETE CURBING, UNLESS OTHERWISE CALLED FOR ON THE PLANS.

THE STANDARD CURB TAPER, CLASS II, SHALL BE USED AT THE ENDS OF ALL COMBINATION CURB AND GUTTER, AND ALL INTEGRAL CONCRETE CURBING, UNLESS OTHERWISE CALLED FOR ON THE PLANS

THE DETAILS AS SHOWN FOR SIDEWALK AND CURB TREATMENT AT DRIVEWAYS ARE TO BE UTILIZED UNLESS OTHERWISE CALLED FOR ON THE PLANS.

SECTION A-A DETAILS A 6' TRANSITION LENGTH IN THE HEIGHT OF THE CURB WHERE DRIVEWAYS AND TYPE IV CURBING ARE ENCOUNTERED.

SECTION B-B & C-C DETAILS ADDITIONAL DEPTH OF SIDEWALK AT DRIVEWAYS AND SECTION D-D DETAILS STANDARD DEPTH SIDEWALK.

SIDEWALK WIDTH SHALL BE EXCLUSIVE OF CURB. WIDTH SHALL BE 5' UNLESS OTHERWISE SHOWN ON PLANS.

SIDEWALK CROSS SLOPE OF 2% IS ABSOLUTE MAXIMUM. THERE IS NO CONSTRUCTION TOLERANCE FOR INCREASED CROSS SLOPE PAST 2%.

SIDEWALKS LESS THAN 5' IN WIDTH SHALL HAVE A 5' X 5' PASSING SPACE AT INTERVALS OF 200' OR LESS.

WEST VIRGINIA DEPARTMENT OF TRANSPORTATION
DIVISION OF HIGHWAYS
STANDARD DETAIL

PREPARED	7-1-99
REVISION DATE	
	7-15-2010
	10-22-2013

CONCRETE CURBING
AND
SIDEWALK
(SHEET 2 of 2)

STANDARD SHEET PVT 6

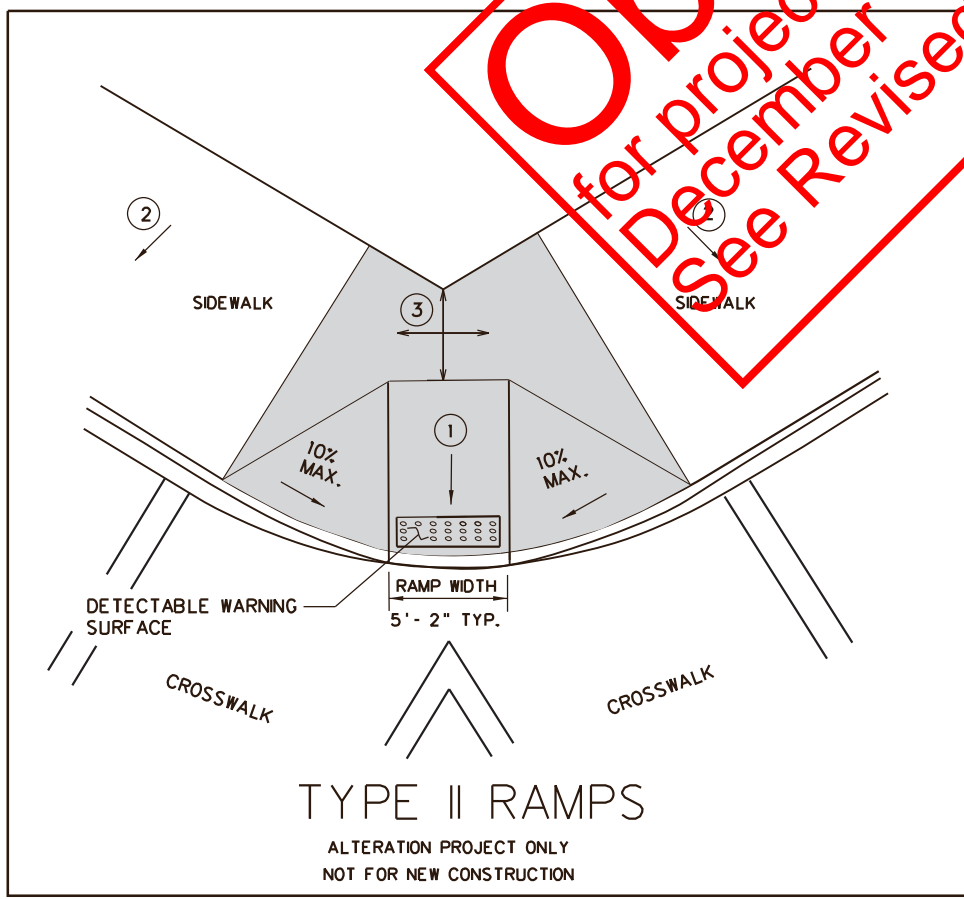
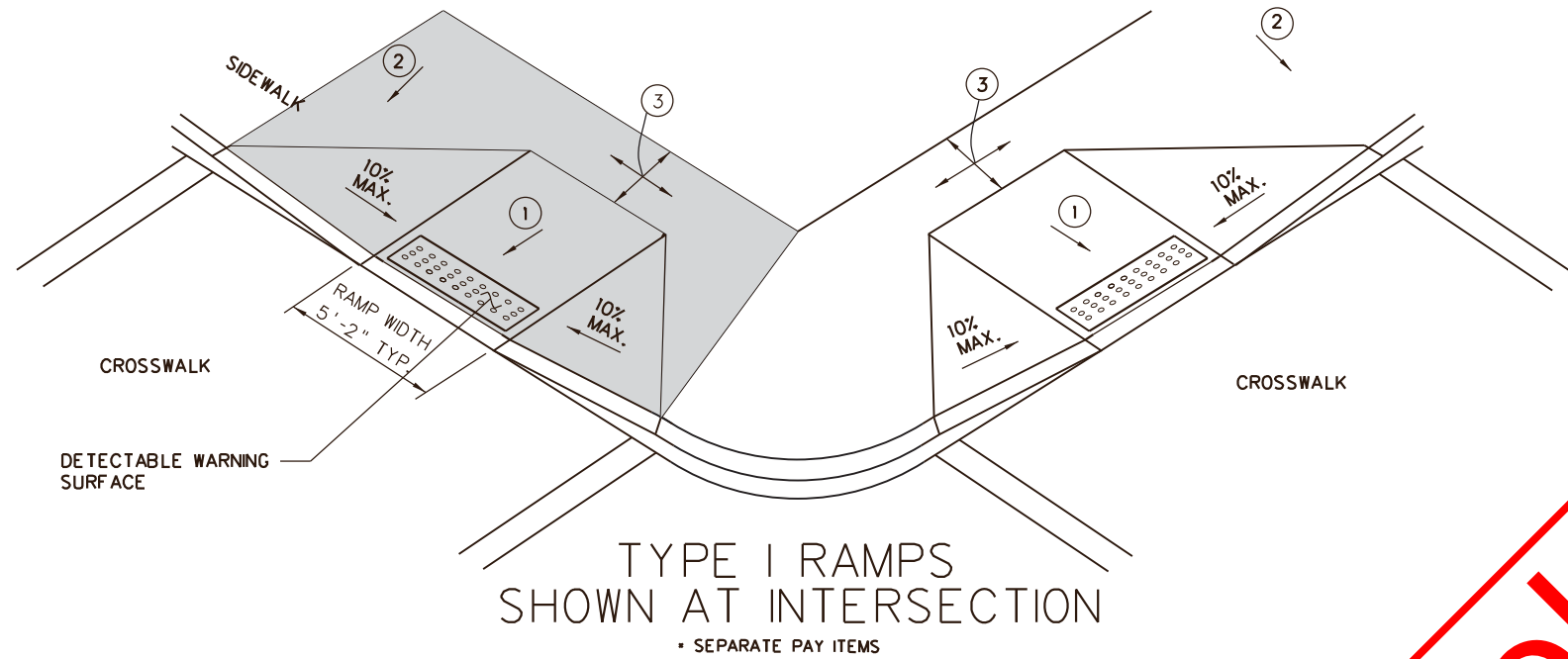

- ① 8.33% (12:1) MAX. RAMP SLOPE, INCLUDING CONSTRUCTION TOLERANCE.
- ② CROSS SLOPE: 2.00% MAX. INCLUDING CONSTRUCTION TOLERANCE.
- ③ CURB RAMPS REQUIRE A (4'-0") MINIMUM TURNING SPACE WITH A MAXIMUM CROSS SLOPE AND LONGITUDINAL SLOPE OF 2.00% WHERE PEDESTRIANS PERFORM TURNING MANEUVERS. SEE NOTE REGARDING OBSTRUCTIONS ON SHEET 1 OF 3. SLOPE TO DRAIN TO CURB.

■ PAY LIMITS FOR CURB RAMPS

Obsolete
 for projects let after
 December 15, 2020
 See Revised Sheet PVT7

NOTES

RAMP CONCRETE SHALL MEET THE REQUIREMENTS OF SECTION 609 OF THE SPECIFICATIONS. RAMP SURFACE SHALL INCLUDE A "DETECTABLE WARNING SURFACE" (SEE PVT7 SHT. 3 OF 3) AS SHOWN FOR EACH RAMP TYPE. A COARSE BROOM FINISH, TRANSVERSE TO FLARE SLOPES, OR EQUAL NON-SKID FINISH SHALL BE PROVIDED ON CONCRETE SURFACES.

NORMAL GUTTER FLOW LINE AND PROFILE SHALL BE MAINTAINED THROUGH THE RAMP AREA, UNLESS OTHERWISE SHOWN OR SPECIFIED.

" PREFORMED EXPANSION JOINT FILLER, MEETING THE REQUIREMENTS OF SECTION 609 OF THE SPECIFICATIONS, SHALL BE PLACED AT ALL LOCATIONS WHERE RAMP CONTACTS CURB, GUTTER, OR CONCRETE PAVEMENT. WHEN THE RAMP IS POURED SEPARATELY FROM THE SIDE WALK, THE EXPANSION MATERIAL SHALL BE PLACED AT ALL LOCATIONS WHERE THE NORMAL SIDEWALK AND THE RAMP ABUT.

DRAINAGE STRUCTURES SHALL NOT BE PLACED IN LINE WITH RAMPS. LOCATION OF THE RAMP SHALL TAKE PRECEDENCE OVER LOCATION OF THE DRAINAGE STRUCTURE, EXCEPT WHERE EXISTING STRUCTURES ARE BEING UTILIZED FOR CONSTRUCTION OF NEW RAMPS.

ANY GRATE IN PEDESTRIAN AREAS SHALL HAVE OPENINGS NOT GREATER THAN 1/2" AND SHALL BE PLACED WITH LONG DIMENSION OF OPENING PERPENDICULAR TO THE DIRECTION OF PEDESTRIAN TRAVEL.

IF THE 8.33% (12:1) SLOPE CANNOT BE OBTAINED DUE TO GRADE OF THE ADJACENT ROADWAY, THE SLOPED PORTION OF THE RAMP SHALL BE EXTENDED TO A MAXIMUM LENGTH OF 15'-0".

A TURNING SPACE AS DEPICTED IN THE DETAILS SHALL BE PROVIDED AT THE TOP OF APPROPRIATE CURB RAMPS. THE TURNING SPACE SHALL HAVE A MINIMUM WIDTH OF 4 FT. WHEN NO OBSTRUCTIONS EXIST AT THE BACKSIDE OF THE LANDING. WHEN AN OBSTRUCTION EXISTS SUCH AS A BUILDING, LIGHT POLE, ETC. THE MINIMUM DIMENSION OF THE LANDING SHALL BE 5 FEET.

CURB RAMP WIDTH SHALL MATCH SIDEWALK WIDTH PLUS CLEARANCE. TYPICAL SIDEWALK WIDTH IS 5'. MINIMUM WIDTH IS 4'.

THE TYPE OF RAMP TO BE USED SHALL BE AS SPECIFIED ON THE PLANS. THE FOLLOWING CAN BE CONSIDERED GUIDELINES IN SELECTING RAMP TYPES, BUT ARE INCLUDED HERE FOR INFORMATION ONLY.

RAMP TYPES

- TYPE I (SHT. 1) FOR USE WHERE SIDEWALK EXTENDS TO STREET AND WHERE SIDEWALK WIDTH IS ADEQUATE FOR RAMP AND TURNING SPACE.
- TYPE II (SHT. 1) RAMP SHALL ONLY BE USED ON ALTERATION PROJECTS WHERE TWO SEPARATE CURB RAMPS CANNOT BE PROVIDED. THE TYPE II CURB IS NOT SUITABLE FOR NEW CONSTRUCTION.
- TYPE III (SHT. 2) PARALLEL RAMPS ARE FOR USE WHEN ADEQUATE SIDEWALK WIDTH FOR BOTH RAMPS AND TURNING SPACE CANNOT BE PROVIDED.
- TYPE IV (SHT. 3) COMBINES ASPECTS OF TYPE I AND TYPE III RAMPS AS NECESSARY. USE WHERE SIDEWALK IS SET BACK FROM STREET AND A GRASS OR LANDSCAPED STRIP IS PROVIDED BETWEEN SIDEWALK AND STREET.

FOR DETECTABLE WARNING SURFACE
NOTES SEE PVT7 SHT. 3 OF 3

NOT TO SCALE

WEST VIRGINIA DEPARTMENT OF TRANSPORTATION
DIVISION OF HIGHWAYS
STANDARD DETAIL

Prepared 7-1-99
REVISION DATE
07/21/10
10/22/13

SIDEWALK RAMPS

(SHEET 1 OF 3)

STANDARD SHEET PVT 7

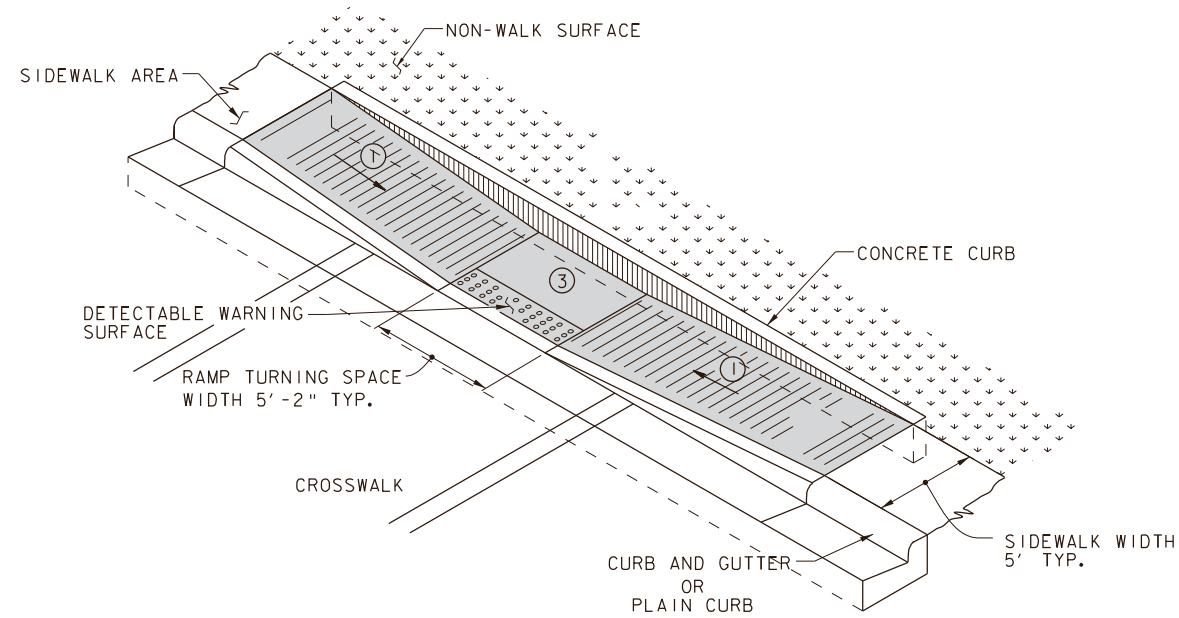

TYPE III

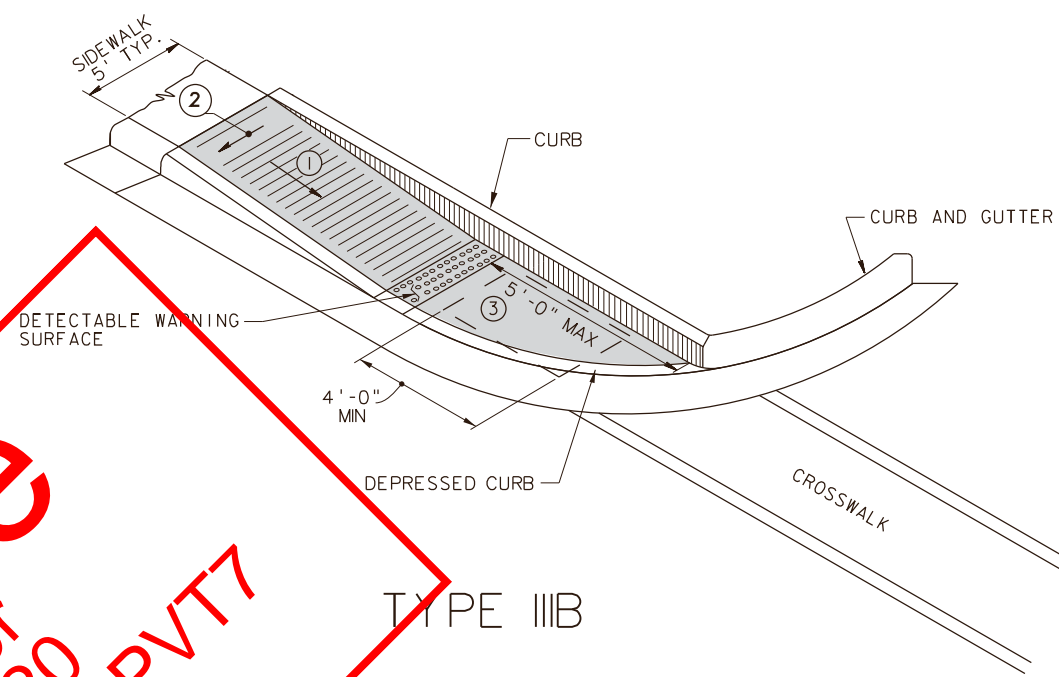

TYPE IIIB

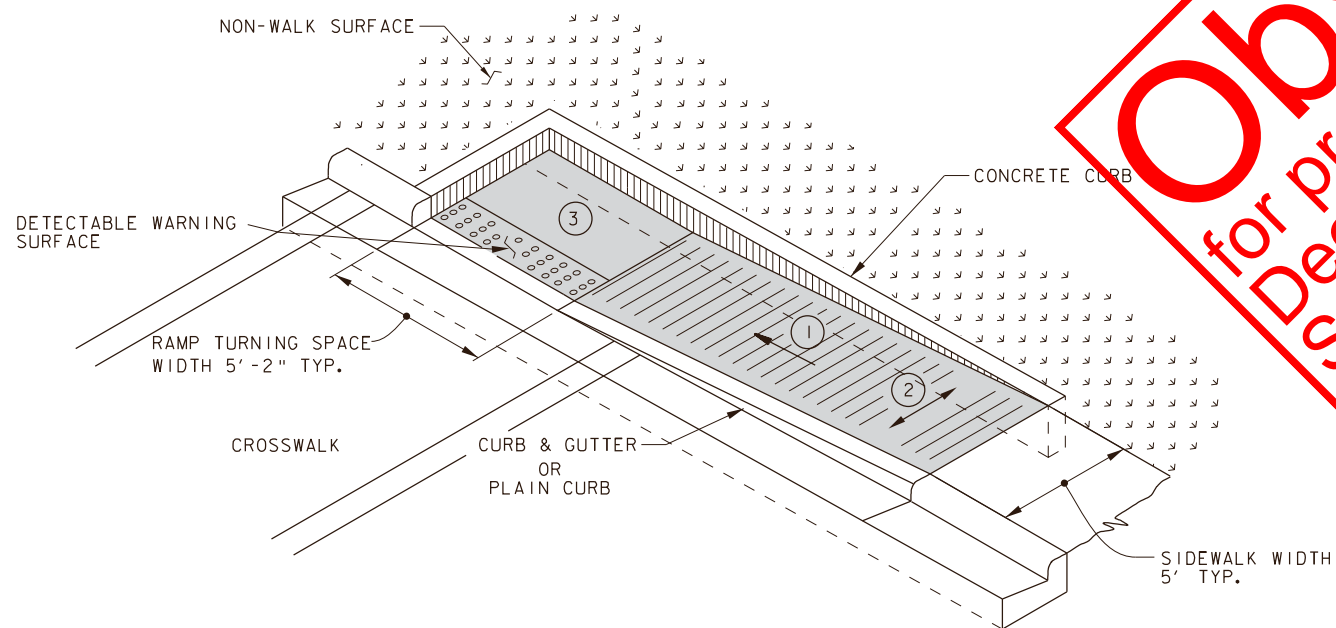

TYPE IIIA

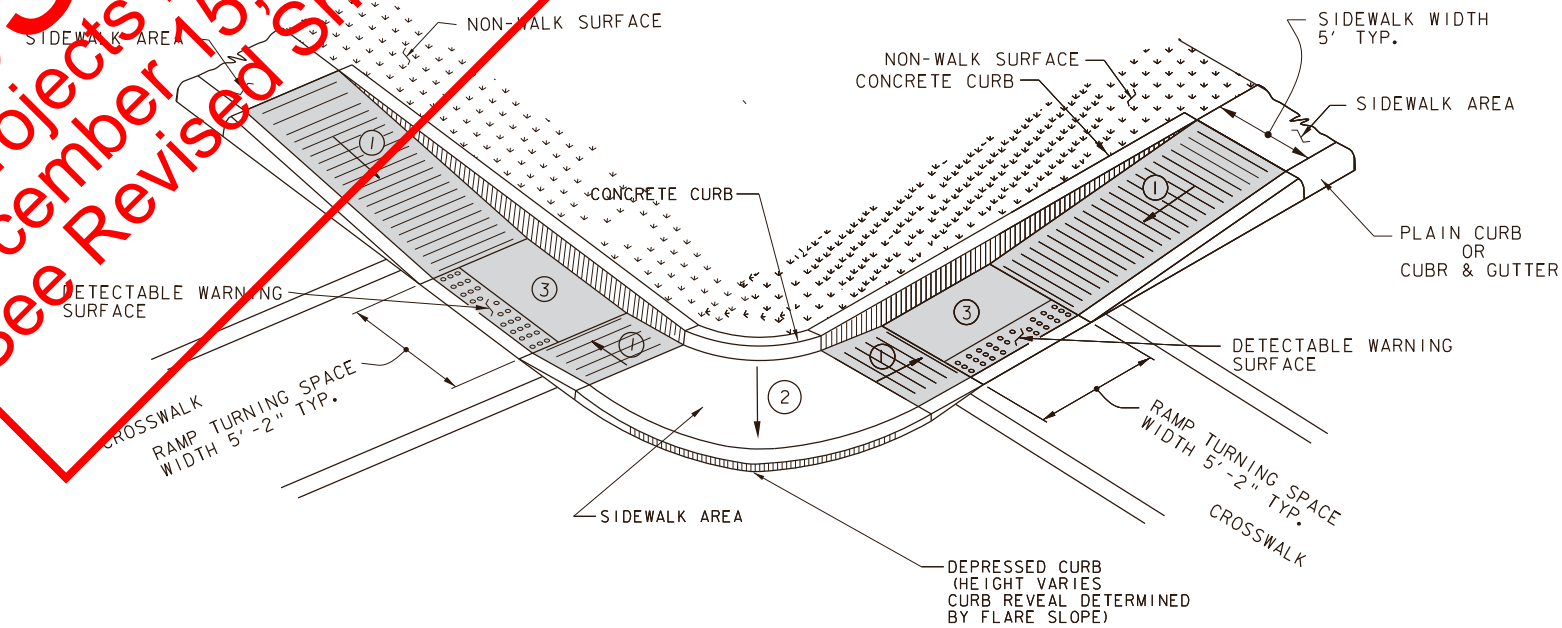

TYPE III RAMPS AT INTERSECTION

Obsolete
 for projects let after
 December 15, 2020
 See Revised Sheet PVT7

- ① 8.33% (12:1) MAX. RAMP SLOPE, INCLUDING CONSTRUCTION TOLERANCE.
- ② CROSS SLOPE: 2.00% MAX. INCLUDING CONSTRUCTION TOLERANCE.
- ③ CURB RAMPS REQUIRE A (4'-0") MINIMUM TURNING SPACE WITH A MAXIMUM CROSS SLOPE AND LONGITUDINAL SLOPE OF 2.00% WHERE PEDESTRIANS PERFORM TURNING MANEUVERS. SEE NOTE REGARDING OBSTRUCTIONS ON SHEET 1 OF 3. SLOPE TO DRAIN TO CURB.

PAY LIMITS FOR CURB RAMPS

CURB MAY NOT BE REQUIRED WHEN WALL OR BUILDING IS PRESENT

FOR DETECTABLE WARNING SURFACE NOTES SEE PVT7 SHT. 3 OF 3

NOT TO SCALE

WEST VIRGINIA DEPARTMENT OF TRANSPORTATION DIVISION OF HIGHWAYS STANDARD DETAIL	
PREPARED 7-1-99	
REVISION DATE	
7/21/10	
10/22/13	
SIDEWALK RAMPS (SHEET 2 OF 3)	
STANDARD SHEET PVT 7	

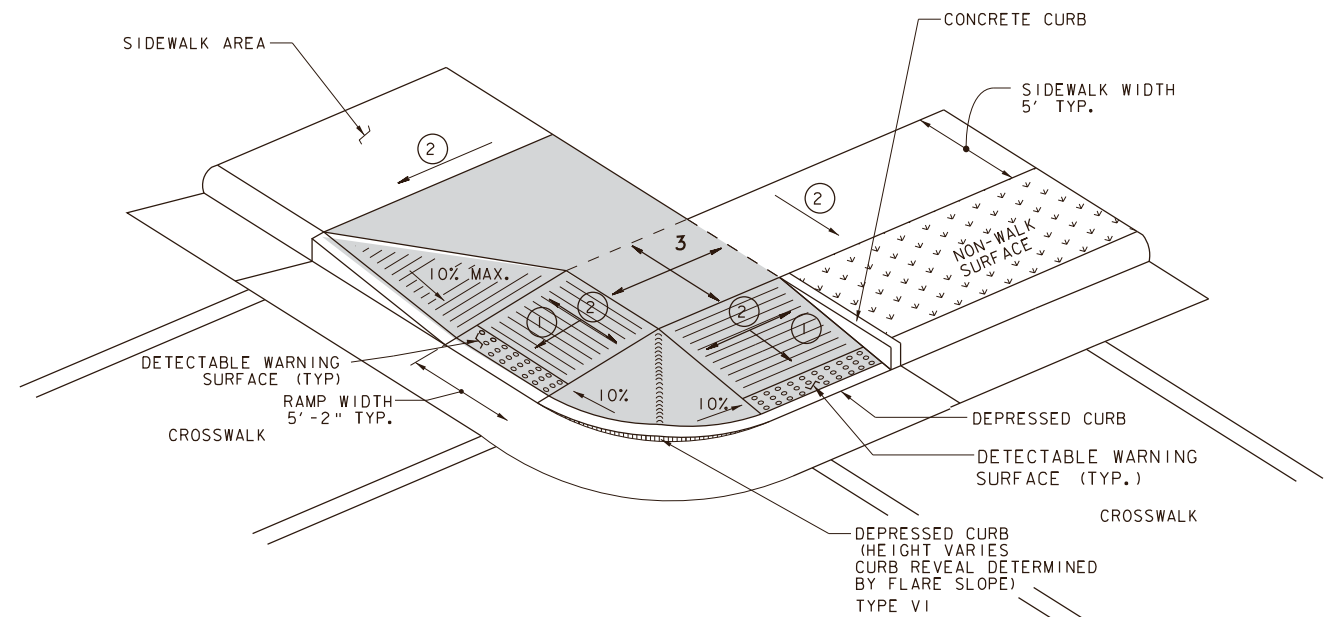

TYPE I

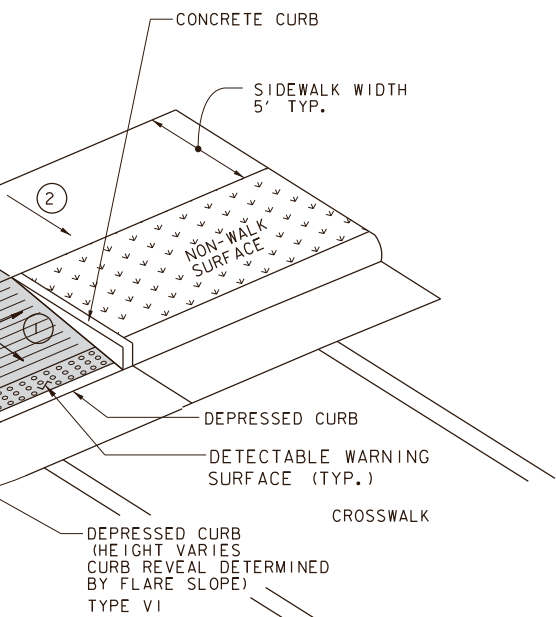

TYPE IV

TYPE I RAMP AND TYPE IV RAMP SHOWN AT INTERSECTION
* TWO SEPARATE PAY ITEMS

Obsolete
for projects let after
December 15, 2020
See Revised Sheet PVT7

NOTES

THE APPROPRIATE DETAILS AND NOTES OF STANDARD SHEET PVT7, SHEETS 1 AND 2 SHALL APPLY TO THIS STANDARD SHEET.

DETECTABLE WARNING SURFACES SHALL EXTEND ACROSS THE FULL WIDTH OF THE CURB RAMP, LANDING OR TRANSITION.

DOMES SHALL BE ALIGNED IN THE PREDOMINANT DIRECTION OF THE CURB RAMP.

DESIGN AND PLACEMENT OF DETECTABLE WARNING SYSTEMS SHALL BE IN ACCORDANCE WITH SECTION 609 OF THE SPECIFICATIONS AND THE PUBLIC RIGHTS OF WAY ACCESSIBILITY GUIDELINES (PROWAG).

DETECTABLE WARNING SURFACE

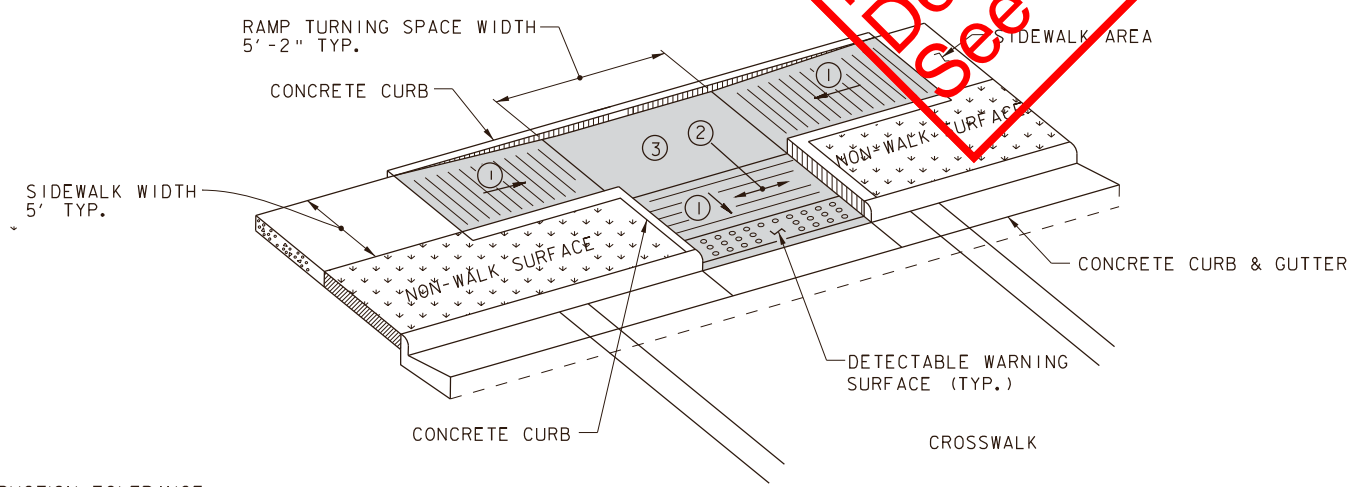

TYPE IV RAMP

- ① 8.33% (12:1) MAX. RAMP SLOPE, INCLUDING CONSTRUCTION TOLERANCE.
- ② CROSS SLOPE: 2.00% MAX. INCLUDING CONSTRUCTION TOLERANCE.
- ③ CURB RAMPS REQUIRE A (4'-0") MINIMUM TURNING SPACE WITH A MAXIMUM CROSS SLOPE AND LONGITUDINAL SLOPE OF 2.00% WHERE PEDESTRIANS PERFORM TURNING MANEUVERS. SEE NOTE REGARDING OBSTRUCTIONS ON SHEET 1 OF 3. SLOPE TO DRAIN TO CURB.

PAY LIMITS FOR CURB RAMPS

NOT TO SCALE

**WEST VIRGINIA DEPARTMENT OF TRANSPORTATION
DIVISION OF HIGHWAYS
STANDARD DETAIL**

REVISION DATE
7/21/10
10/22/13

**SIDEWALK RAMPS
(SHEET 3 OF 3)**

SHEET PVT 7

NOTES

THE TYPE OF RAMP TO BE USED SHALL BE AS SPECIFIED ON THE PLANS. THESE STANDARDS CAN BE CONSIDERED GUIDELINES IN SELECTING RAMP TYPES, HOWEVER THEY CAN BE DEVIATED FROM WITH A SPECIAL DETAIL AS NOTED IN PLANS.

RAMP CONCRETE SHALL MEET THE REQUIREMENTS OF SECTION 609 OF THE CURRENT WVDOT, DOH STANDARD SPECIFICATIONS ROADS AND BRIDGES AND ANY SUBSEQUENT DOH SUPPLEMENTAL SPECIFICATIONS, AND THE PUBLIC RIGHTS OF WAY ACCESSIBILITY GUIDELINES (PROWAG) DATED JULY 26, 2011. RAMP SURFACE SHALL INCLUDE A "DETECTABLE WARNING SURFACE" (SEE PVT 7 SHT. 11 OF 13) AS SHOWN FOR EACH RAMP TYPE. A COARSE BROOM FINISH, TRANSVERSE TO FLARE SLOPES, OR EQUAL NON-SKID FINISH SHALL BE PROVIDED ON CONCRETE SURFACES.

NORMAL GUTTER FLOW LINE AND PROFILE SHALL BE MAINTAINED THROUGH THE RAMP AREA, UNLESS OTHERWISE SHOWN OR SPECIFIED. POSITIVE DRAINAGE MUST BE MAINTAINED SO THAT NO PONDING OCCURS WITHIN THE RAMP OR CLEAR SPACE AREA.

1/4" MINIMUM, 1/2" MAXIMUM PREFORMED EXPANSION JOINT FILLER, MEETING THE REQUIREMENTS OF SECTION 609 OF THE SPECIFICATIONS, AS NOTED ABOVE, SHALL BE PLACED AT ALL LOCATIONS WHERE RAMP CONTACTS CURB, GUTTER, CONCRETE PAVEMENT, OR OTHER RIGID OBJECTS.

WHERE EXISTING SIDEWALK CONNECTS TO PROPOSED SIDEWALK OR RAMPS, EXPANSION JOINTS ALONG WITH DOWEL BARS WILL BE PLACED. DOWEL BARS WILL BE UTILIZED BETWEEN EXISTING AND PROPOSED TO REDUCE VERTICAL CHANGE. SEE SHEET 11 FOR ADDITIONAL INFORMATION.

SAWCUTS WILL BE UTILIZED DURING DEMOLITION OF EXISTING SIDEWALKS. SIMILAR METHODS MAY BE USED UPON APPROVAL BY FIELD ENGINEER.

RAMPS SHALL NOT BE PLACED IN LINE WITH DRAINAGE STRUCTURES. LOCATION OF THE RAMP SHALL TAKE PRECEDENCE OVER LOCATION OF THE DRAINAGE STRUCTURE, EXCEPT WHERE EXISTING STRUCTURES ARE BEING UTILIZED FOR CONSTRUCTION OF NEW RAMPS.

ANY GRATE IN PEDESTRIAN AREAS SHALL HAVE OPENINGS NOT GREATER THAN 1/2" AND SHALL BE PLACED WITH LONG DIMENSION OF OPENING PERPENDICULAR TO THE DIRECTION OF PEDESTRIAN TRAVEL.

IF THE 8.33% (12:1) SLOPE CANNOT BE OBTAINED DUE TO GRADE OF THE ADJACENT ROADWAY, THE SLOPED PORTION OF THE RAMP SHALL BE EXTENDED TO A MINIMUM LENGTH OF 15'-0".

EXISTING CROSS WALK AND STOP BAR MARKINGS TO BE ERADICATED AND RELOCATED AS DICTATED BY PROPOSED RAMP LOCATIONS. COST NOT INCIDENTAL TO COST OF PROPOSED RAMP.

CURB RAMP WIDTH SHALL MATCH SIDEWALK WIDTH PLUS CLEARANCE. TYPICAL SIDEWALK WIDTH IS 5' MINIMUM. RAMP WIDTHS LESS THAN 5' REQUIRE DIVISION/DISTRICT ENGINEER APPROVAL. WIDTHS LESS THAN 4' REQUIRE AN EXCEPTION JUSTIFICATION REPORT. SEE SHEET 11 FOR INFORMATION REGARDING RAMP THICKNESS.

GRADE BREAKS SHALL BE PERPENDICULAR TO THE DIRECTION OF THE RAMP RUN. SURFACE SLOPES THAT MEET AT GRADE BREAKS SHALL BE FLUSH.

CLEAR SPACE- BEYOND THE BOTTOM GRADE BREAK, A CLEAR SPACE THE WIDTH OF THE CURB RAMP AND EXTENDING 4' MINIMUM INTO THE ABUTTING ROADWAY SHALL BE PROVIDED WITHIN THE WIDTH OF THE PEDESTRIAN STREET CROSSING AND WHOLLY OUTSIDE THE PARALLEL TRAVEL LANE. SURFACE TO MATCH EXISTING. ANY CLEAR SPACE WORK TO BE COMPLETED WILL BE INCIDENTAL TO THE COST OF THE RAMP.

ALL CURB RAMPS SHALL BE CONSTRUCTED TO PROVIDE ACCESS TO EXISTING OPERABLE PARTS. AN EXAMPLE OF THIS WOULD BE PEDESTRIAN PUSH BUTTONS.

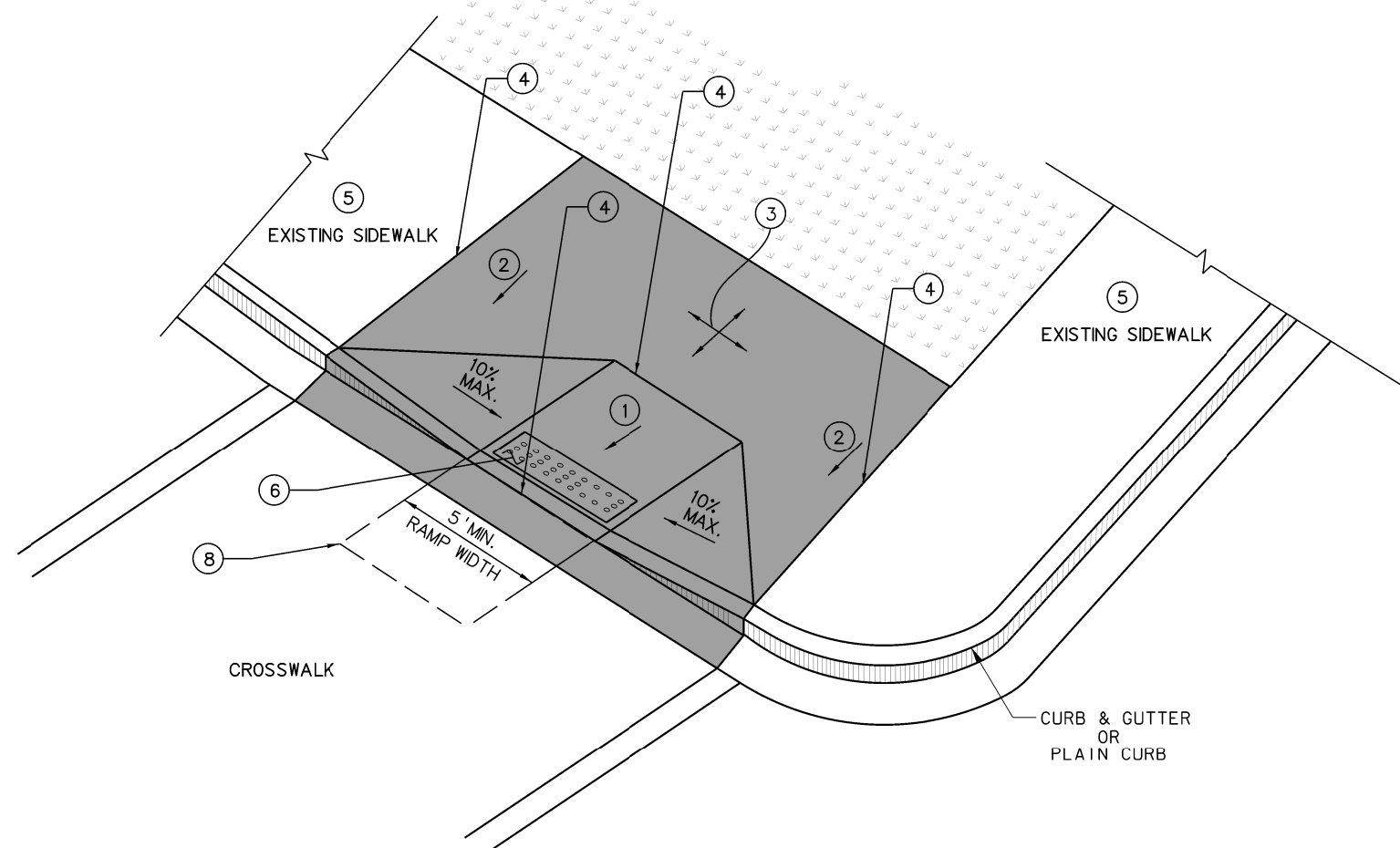

TYPE I RAMP

LEGEND

- ① 8.33% (12:1) MAXIMUM RAMP SLOPE INCLUDING CONSTRUCTION TOLERANCE SLOPE OF RAMP SHALL CARRY THROUGH TO FACE OF CURB
- ② CROSS SLOPE: 2.00% MAXIMUM INCLUDING CONSTRUCTION TOLERANCE
- ③ CURB RAMPS REQUIRE A (5'-0") MINIMUM TURNING SPACE WHERE PEDESTRIANS PERFORM TURNING MANEUVERS WITH A MAXIMUM CROSS SLOPE OF 2% AND LONGITUDINAL SLOPE MATCHING ROADWAY
- ④ GRADE BREAK REQUIRED TO BE FLUSH (0") AND PERPENDICULAR TO PEDESTRIAN PATH OF TRAVEL
- ⑤ IF SIDEWALK IS EXISTING AND NON-COMPLIANT SEE "TRANSITION TO EXISTING NON-COMPLIANT SIDEWALK" DETAIL SHEET 12
- ⑥ DETECTABLE WARNING SURFACE SEE "DETECTABLE WARNING SURFACE (DWS)" DETAIL SHEET 11
- ⑦ CURB WALL OR CHEEK WALL AS DICTATED BY FIELD CONDITIONS. SEE "EXISTING ADJACENT SURFACE TRANSITION" DETAIL SHEET 13
- ⑧ CLEAR SPACE - WIDTH OF CURB RAMP AND EXTENDING 4' MINIMUM
- ⑨ 3/4" CHAMFER EDGE

PAY LIMITS FOR CURB RAMPS (EXCLUDING DWS)

NOT TO SCALE

**WEST VIRGINIA DEPARTMENT OF TRANSPORTATION
DIVISION OF HIGHWAYS
STANDARD DETAIL**

PREPARED 1-1-1999

REVISION DATE
7/21/10
10/22/13
10/01/20

**SIDEWALK RAMPS
(Sheet 1 of 13)
TYPE I RAMP**

STANDARD SHEET PVT 7

NOTES

THE TYPE OF RAMP TO BE USED SHALL BE AS SPECIFIED ON THE PLANS. THESE STANDARDS CAN BE CONSIDERED GUIDELINES IN SELECTING RAMP TYPES, HOWEVER THEY CAN BE DEVIATED FROM WITH A SPECIAL DETAIL AS NOTED IN PLANS.

RAMP CONCRETE SHALL MEET THE REQUIREMENTS OF SECTION 609 OF THE CURRENT WVDOT, DOH STANDARD SPECIFICATIONS ROADS AND BRIDGES AND ANY SUBSEQUENT DOH SUPPLEMENTAL SPECIFICATIONS, AND THE PUBLIC RIGHTS OF WAY ACCESSIBILITY GUIDELINES (PROWAG) DATED JULY 26, 2011. RAMP SURFACE SHALL INCLUDE A "DETECTABLE WARNING SURFACE" (SEE PVT7 SHT. 11 OF 13) AS SHOWN FOR EACH RAMP TYPE. A COARSE BROOM FINISH, TRANSVERSE TO FLARE SLOPES, OR EQUAL NON-SKID FINISH SHALL BE PROVIDED ON CONCRETE SURFACES.

NORMAL GUTTER FLOW LINE AND PROFILE SHALL BE MAINTAINED THROUGH THE RAMP AREA, UNLESS OTHERWISE SHOWN OR SPECIFIED. POSITIVE DRAINAGE MUST BE MAINTAINED SO THAT NO PONDING OCCURS WITHIN THE RAMP OR CLEAR SPACE AREA.

1/4" MINIMUM, 1/2" MAXIMUM PREFORMED EXPANSION JOINT FILLER, MEETING THE REQUIREMENTS OF SECTION 609 OF THE SPECIFICATIONS, AS NOTED ABOVE, SHALL BE PLACED AT ALL LOCATIONS WHERE RAMP CONTACTS CURB, GUTTER, CONCRETE PAVEMENT, OR OTHER RIGID OBJECTS.

WHERE EXISTING SIDEWALK CONNECTS TO PROPOSED SIDEWALK OR RAMPS, EXPANSION JOINTS ALONG WITH DOWEL BARS WILL BE PLACED. DOWEL BARS WILL BE UTILIZED BETWEEN EXISTING AND PROPOSED TO REDUCE VERTICAL CHANGE. SEE SHEET 11 FOR ADDITIONAL INFORMATION.

SAWCUTS WILL BE UTILIZED DURING DEMOLITION OF EXISTING SIDEWALKS. SIMILAR METHODS MAY BE USED UPON APPROVAL BY FIELD ENGINEER.

RAMPS SHALL NOT BE PLACED IN LINE WITH DRAINAGE STRUCTURES. LOCATION OF THE RAMP SHALL TAKE PRECEDENCE OVER LOCATION OF THE DRAINAGE STRUCTURE, EXCEPT WHERE EXISTING STRUCTURES ARE BEING UTILIZED FOR CONSTRUCTION OF NEW RAMPS.

ANY GRATE IN PEDESTRIAN AREAS SHALL HAVE OPENINGS NOT GREATER THAN 1/2" AND SHALL BE PLACED WITH LONG DIMENSION OF OPENING PERPENDICULAR TO THE DIRECTION OF PEDESTRIAN TRAVEL.

IF THE 8.33% (12:1) SLOPE CANNOT BE OBTAINED DUE TO GRADE OF THE ADJACENT ROADWAY, THE SLOPED PORTION OF THE RAMP SHALL BE EXTENDED TO A MINIMUM LENGTH OF 15'-0".

EXISTING CROSS WALK AND STOP BAR MARKINGS TO BE ERADICATED AND RELOCATED AS DICTATED BY PROPOSED RAMP LOCATIONS. COST NOT INCIDENTAL TO COST OF PROPOSED RAMP.

CURB RAMP WIDTH SHALL MATCH SIDEWALK WIDTH PLUS CLEARANCE. TYPICAL SIDEWALK WIDTH IS 5' MINIMUM. RAMP WIDTHS LESS THAN 5' REQUIRE DIVISION/DISTRICT ENGINEER APPROVAL. WIDTHS LESS THAN 4' REQUIRE AN EXCEPTION JUSTIFICATION REPORT. SEE SHEET 11 FOR INFORMATION REGARDING RAMP THICKNESS.

GRADE BREAKS SHALL BE PERPENDICULAR TO THE DIRECTION OF THE RAMP RUN. SURFACE SLOPES THAT MEET AT GRADE BREAKS SHALL BE FLUSH.

CLEAR SPACE- BEYOND THE BOTTOM GRADE BREAK, A CLEAR SPACE THE WIDTH OF THE CURB RAMP AND EXTENDING 4' MINIMUM INTO THE ABUTTING ROADWAY SHALL BE PROVIDED WITHIN THE WIDTH OF THE PEDESTRIAN STREET CROSSING AND WHOLLY OUTSIDE THE PARALLEL TRAVEL LANE. SURFACE TO MATCH EXISTING. ANY CLEAR SPACE WORK TO BE COMPLETED WILL BE INCIDENTAL TO THE COST OF THE RAMP.

ALL CURB RAMPS SHALL BE CONSTRUCTED TO PROVIDE ACCESS TO EXISTING OPERABLE PARTS. AN EXAMPLE OF THIS WOULD BE PEDESTRIAN PUSH BUTTONS.

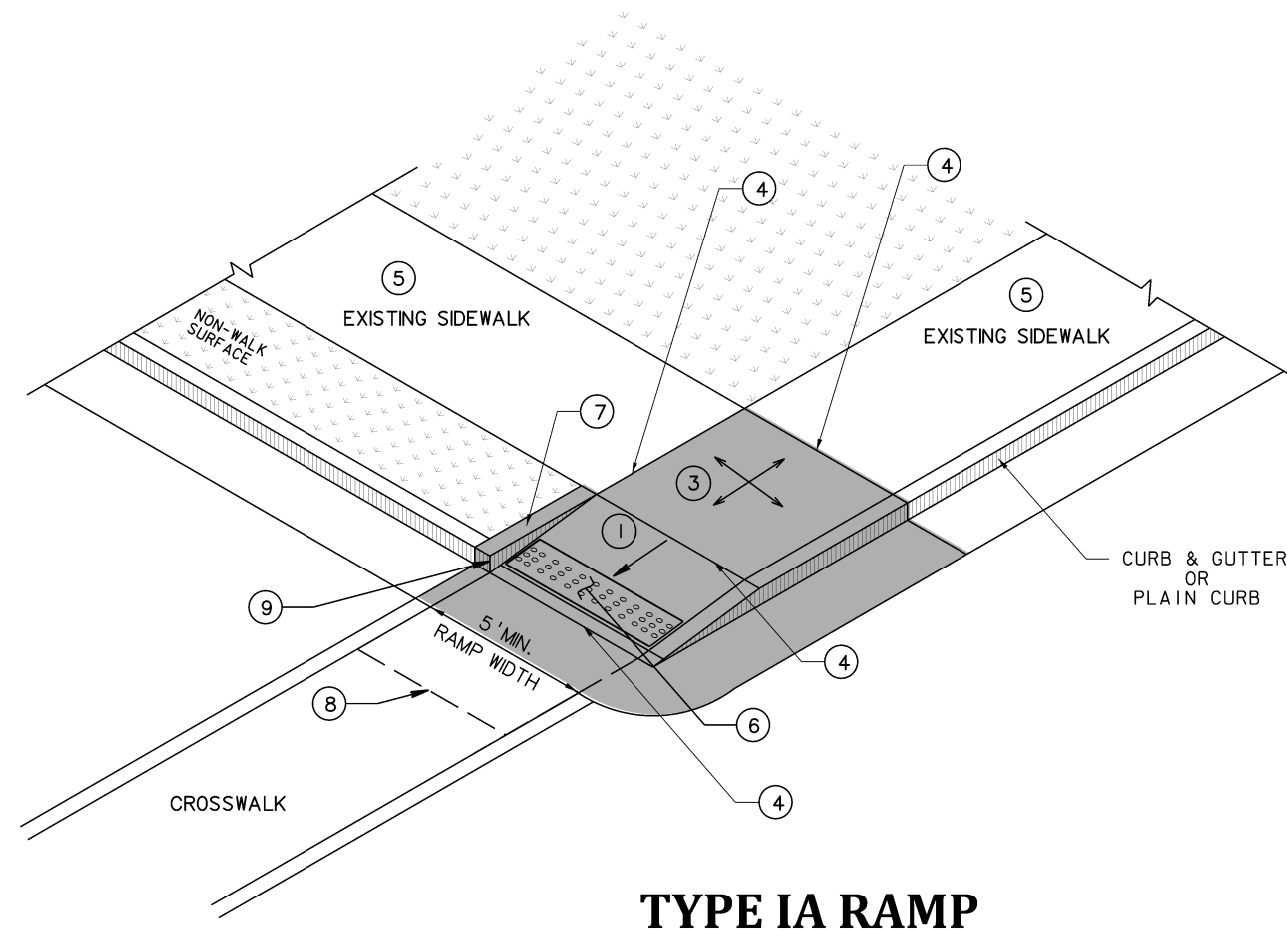

TYPE IA RAMP

LEGEND

- ① 8.33% (12:1) MAXIMUM RAMP SLOPE INCLUDING CONSTRUCTION TOLERANCE
SLOPE OF RAMP SHALL CARRY THROUGH TO FACE OF CURB
- ② CROSS SLOPE: 2.00% MAXIMUM INCLUDING CONSTRUCTION TOLERANCE
- ③ CURB RAMPS REQUIRE A (5'-0") MINIMUM TURNING SPACE WHERE PEDESTRIANS
PERFORM TURNING MANEUVERS WITH A MAXIMUM CROSS SLOPE OF 2% AND
LONGITUDINAL SLOPE MATCHING ROADWAY
- ④ GRADE BREAK REQUIRED TO BE FLUSH (0") AND PERPENDICULAR TO
PEDESTRIAN PATH OF TRAVEL
- ⑤ IF SIDEWALK IS EXISTING AND NON-COMPLIANT SEE "TRANSITION
TO EXISTING NON-COMPLIANT SIDEWALK" DETAIL SHEET 12
- ⑥ DETECTABLE WARNING SURFACE
SEE "DETECTABLE WARNING SURFACE (DWS)" DETAIL SHEET 11
- ⑦ CURB WALL OR CHEEK WALL AS DICTATED BY FIELD
CONDITIONS. SEE "EXISTING ADJACENT SURFACE TRANSITION"
DETAIL SHEET 13
- ⑧ CLEAR SPACE - WIDTH OF CURB RAMP AND EXTENDING 4'
MINIMUM
- ⑨ 3/4" CHAMFER EDGE



PAY LIMITS FOR CURB RAMPS
(EXCLUDING DWS)

NOT TO SCALE

**WEST VIRGINIA DEPARTMENT OF TRANSPORTATION
DIVISION OF HIGHWAYS
STANDARD DETAIL**

PREPARED 1-1-1999

REVISION DATE
7/21/10
10/22/13
10/01/20

**SIDEWALK RAMPS
(Sheet 2 of 13)
TYPE IA RAMP**

STANDARD SHEET PVT 7

NOTES

THE TYPE OF RAMP TO BE USED SHALL BE AS SPECIFIED ON THE PLANS. THESE STANDARDS CAN BE CONSIDERED GUIDELINES IN SELECTING RAMP TYPES, HOWEVER THEY CAN BE DEVIATED FROM WITH A SPECIAL DETAIL AS NOTED IN PLANS.

RAMP CONCRETE SHALL MEET THE REQUIREMENTS OF SECTION 609 OF THE CURRENT WVDOT, DOH STANDARD SPECIFICATIONS ROADS AND BRIDGES AND ANY SUBSEQUENT DOH SUPPLEMENTAL SPECIFICATIONS, AND THE PUBLIC RIGHTS OF WAY ACCESSIBILITY GUIDELINES (PROWAG) DATED JULY 26, 2011. RAMP SURFACE SHALL INCLUDE A "DETECTABLE WARNING SURFACE" (SEE PVT7 SHT. 11 OF 13) AS SHOWN FOR EACH RAMP TYPE. A COARSE BROOM FINISH, TRANSVERSE TO FLARE SLOPES, OR EQUAL NON-SKID FINISH SHALL BE PROVIDED ON CONCRETE SURFACES.

NORMAL GUTTER FLOW LINE AND PROFILE SHALL BE MAINTAINED THROUGH THE RAMP AREA, UNLESS OTHERWISE SHOWN OR SPECIFIED. POSITIVE DRAINAGE MUST BE MAINTAINED SO THAT NO PONDING OCCURS WITHIN THE RAMP OR CLEAR SPACE AREA.

1/4" MINIMUM, 1/2" MAXIMUM PREFORMED EXPANSION JOINT FILLER, MEETING THE REQUIREMENTS OF SECTION 609 OF THE SPECIFICATIONS, AS NOTED ABOVE, SHALL BE PLACED AT ALL LOCATIONS WHERE RAMP CONTACTS CURB, GUTTER, CONCRETE PAVEMENT, OR OTHER RIGID OBJECTS.

WHERE EXISTING SIDEWALK CONNECTS TO PROPOSED SIDEWALK OR RAMPS, EXPANSION JOINTS ALONG WITH DOWEL BARS WILL BE PLACED. DOWEL BARS WILL BE UTILIZED BETWEEN EXISTING AND PROPOSED TO REDUCE VERTICAL CHANGE. SEE SHEET 11 FOR ADDITIONAL INFORMATION.

SAWCUTS WILL BE UTILIZED DURING DEMOLITION OF EXISTING SIDEWALKS. SIMILAR METHODS MAY BE USED UPON APPROVAL BY FIELD ENGINEER.

RAMPS SHALL NOT BE PLACED IN LINE WITH DRAINAGE STRUCTURES. LOCATION OF THE RAMP SHALL TAKE PRECEDENCE OVER LOCATION OF THE DRAINAGE STRUCTURE, EXCEPT WHERE EXISTING STRUCTURES ARE BEING UTILIZED FOR CONSTRUCTION OF NEW RAMPS.

ANY GRATE IN PEDESTRIAN AREAS SHALL HAVE OPENINGS NOT GREATER THAN 1/2" AND SHALL BE PLACED WITH LONG DIMENSION OF OPENING PERPENDICULAR TO THE DIRECTION OF PEDESTRIAN TRAVEL.

IF THE 8.33% (12:1) SLOPE CANNOT BE OBTAINED DUE TO GRADE OF THE ADJACENT ROADWAY, THE SLOPED PORTION OF THE RAMP SHALL BE EXTENDED TO A MINIMUM LENGTH OF 15'-0".

EXISTING CROSS WALK AND STOP BAR MARKINGS TO BE ERADICATED AND RELOCATED AS DICTATED BY PROPOSED RAMP LOCATIONS. COST NOT INCIDENTAL TO COST OF PROPOSED RAMP.

CURB RAMP WIDTH SHALL MATCH SIDEWALK WIDTH PLUS CLEARANCE. TYPICAL SIDEWALK WIDTH IS 5' MINIMUM. RAMP WIDTHS LESS THAN 5' REQUIRE DIVISION/DISTRICT ENGINEER APPROVAL. WIDTHS LESS THAN 4' REQUIRE AN EXCEPTION JUSTIFICATION REPORT. SEE SHEET 11 FOR INFORMATION REGARDING RAMP THICKNESS.

GRADE BREAKS SHALL BE PERPENDICULAR TO THE DIRECTION OF THE RAMP RUN. SURFACE SLOPES THAT MEET AT GRADE BREAKS SHALL BE FLUSH.

CLEAR SPACE- BEYOND THE BOTTOM GRADE BREAK, A CLEAR SPACE THE WIDTH OF THE CURB RAMP AND EXTENDING 4' MINIMUM INTO THE ABUTTING ROADWAY SHALL BE PROVIDED WITHIN THE WIDTH OF THE PEDESTRIAN STREET CROSSING AND WHOLLY OUTSIDE THE PARALLEL TRAVEL LANE. SURFACE TO MATCH EXISTING. ANY CLEAR SPACE WORK TO BE COMPLETED WILL BE INCIDENTAL TO THE COST OF THE RAMP.

ALL CURB RAMPS SHALL BE CONSTRUCTED TO PROVIDE ACCESS TO EXISTING OPERABLE PARTS. AN EXAMPLE OF THIS WOULD BE PEDESTRIAN PUSH BUTTONS.

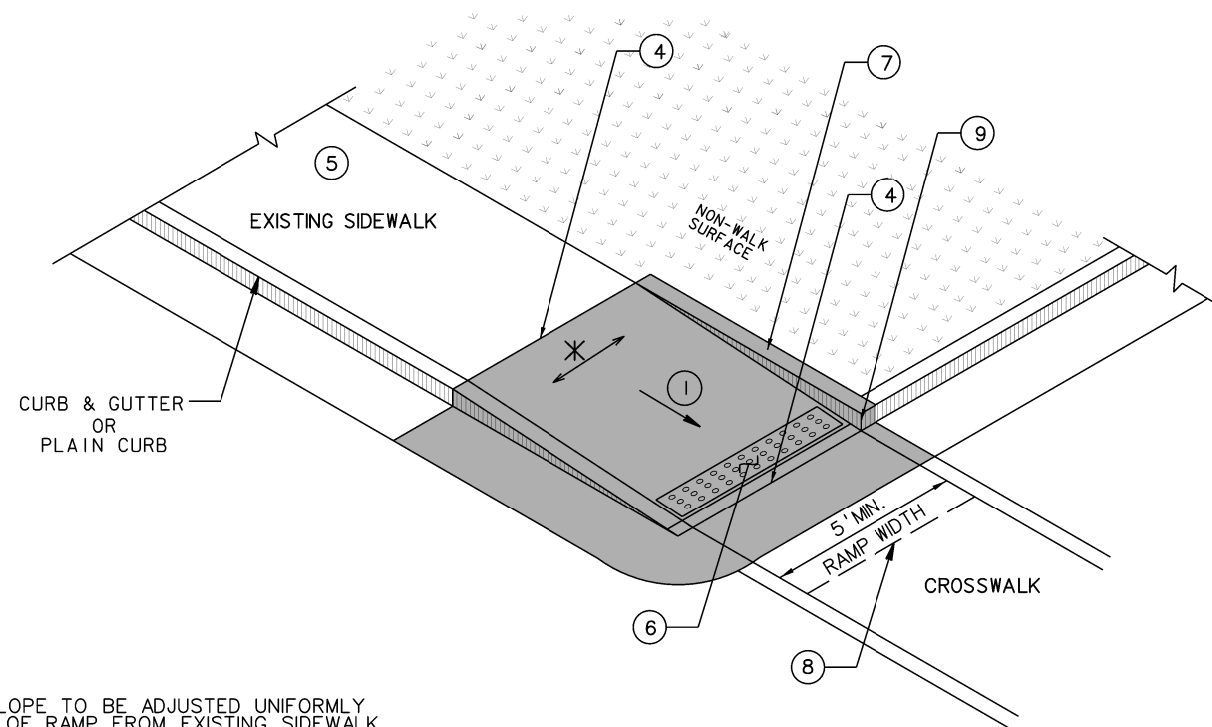

* RAMP CROSS SLOPE TO BE ADJUSTED UNIFORMLY ALONG LENGTH OF RAMP FROM EXISTING SIDEWALK TO GRADE OF CONNECTING ROADWAY.

TYPE IB RAMP

LEGEND

- ① 8.33% (12:1) MAXIMUM RAMP SLOPE INCLUDING CONSTRUCTION TOLERANCE SLOPE OF RAMP SHALL CARRY THROUGH TO FACE OF CURB
- ② CROSS SLOPE: 2.00% MAXIMUM INCLUDING CONSTRUCTION TOLERANCE
- ③ CURB RAMPS REQUIRE A (5'-0") MINIMUM TURNING SPACE WHERE PEDESTRIANS PERFORM TURNING MANEUVERS WITH A MAXIMUM CROSS SLOPE OF 2% AND LONGITUDINAL SLOPE MATCHING ROADWAY
- ④ GRADE BREAK REQUIRED TO BE FLUSH (0") AND PERPENDICULAR TO PEDESTRIAN PATH OF TRAVEL
- ⑤ IF SIDEWALK IS EXISTING AND NON-COMPLIANT SEE "TRANSITION TO EXISTING NON-COMPLIANT SIDEWALK" DETAIL SHEET 12
- ⑥ DETECTABLE WARNING SURFACE SEE "DETECTABLE WARNING SURFACE (DWS)" DETAIL SHEET 11
- ⑦ CURB WALL OR CHEEK WALL AS DICTATED BY FIELD CONDITIONS. SEE "EXISTING ADJACENT SURFACE TRANSITION" DETAIL SHEET 13
- ⑧ CLEAR SPACE - WIDTH OF CURB RAMP AND EXTENDING 4' MINIMUM
- ⑨ 3/4" CHAMFER EDGE

PAY LIMITS FOR CURB RAMPS (EXCLUDING DWS)

NOT TO SCALE

WEST VIRGINIA DEPARTMENT OF TRANSPORTATION DIVISION OF HIGHWAYS STANDARD DETAIL	
PREPARED 1-1-1999	
REVISION DATE	
7/21/10	
10/22/13	
10/01/20	
SIDEWALK RAMPS (Sheet 3 of 13) TYPE IB RAMP	
STANDARD SHEET PVT 7	

NOTES

THE TYPE OF RAMP TO BE USED SHALL BE AS SPECIFIED ON THE PLANS. THESE STANDARDS CAN BE CONSIDERED GUIDELINES IN SELECTING RAMP TYPES, HOWEVER THEY CAN BE DEVIATED FROM WITH A SPECIAL DETAIL AS NOTED IN PLANS.

RAMP CONCRETE SHALL MEET THE REQUIREMENTS OF SECTION 609 OF THE CURRENT WVDOT, DOH STANDARD SPECIFICATIONS ROADS AND BRIDGES AND ANY SUBSEQUENT DOH SUPPLEMENTAL SPECIFICATIONS, AND THE PUBLIC RIGHTS OF WAY ACCESSIBILITY GUIDELINES (PROWAG) DATED JULY 26, 2011. RAMP SURFACE SHALL INCLUDE A "DETECTABLE WARNING SURFACE" (SEE PVT7 SHT. 11 OF 13) AS SHOWN FOR EACH RAMP TYPE. A COARSE BROOM FINISH, TRANSVERSE TO FLARE SLOPES, OR EQUAL NON-SKID FINISH SHALL BE PROVIDED ON CONCRETE SURFACES.

NORMAL GUTTER FLOW LINE AND PROFILE SHALL BE MAINTAINED THROUGH THE RAMP AREA, UNLESS OTHERWISE SHOWN OR SPECIFIED. POSITIVE DRAINAGE MUST BE MAINTAINED SO THAT NO PONDING OCCURS WITHIN THE RAMP OR CLEAR SPACE AREA.

1/4" MINIMUM, 1/2" MAXIMUM PREFORMED EXPANSION JOINT FILLER, MEETING THE REQUIREMENTS OF SECTION 609 OF THE SPECIFICATIONS, AS NOTED ABOVE, SHALL BE PLACED AT ALL LOCATIONS WHERE RAMP CONTACTS CURB, GUTTER, CONCRETE PAVEMENT, OR OTHER RIGID OBJECTS.

WHERE EXISTING SIDEWALK CONNECTS TO PROPOSED SIDEWALK OR RAMPS, EXPANSION JOINTS ALONG WITH DOWEL BARS WILL BE PLACED. DOWEL BARS WILL BE UTILIZED BETWEEN EXISTING AND PROPOSED TO REDUCE VERTICAL CHANGE. SEE SHEET 11 FOR ADDITIONAL INFORMATION.

SAWCUTS WILL BE UTILIZED DURING DEMOLITION OF EXISTING SIDEWALKS. SIMILAR METHODS MAY BE USED UPON APPROVAL BY FIELD ENGINEER.

RAMPS SHALL NOT BE PLACED IN LINE WITH DRAINAGE STRUCTURES. LOCATION OF THE RAMP SHALL TAKE PRECEDENCE OVER LOCATION OF THE DRAINAGE STRUCTURE, EXCEPT WHERE EXISTING STRUCTURES ARE BEING UTILIZED FOR CONSTRUCTION OF NEW RAMPS.

ANY GRATE IN PEDESTRIAN AREAS SHALL HAVE OPENINGS NOT GREATER THAN 1/2" AND SHALL BE PLACED WITH LONG DIMENSION OF OPENING PERPENDICULAR TO THE DIRECTION OF PEDESTRIAN TRAVEL.

IF THE 8.33% (12:1) SLOPE CANNOT BE OBTAINED DUE TO GRADE OF THE ADJACENT ROADWAY, THE SLOPED PORTION OF THE RAMP SHALL BE EXTENDED TO A MINIMUM LENGTH OF 15'-0".

EXISTING CROSS WALK AND STOP BAR MARKINGS TO BE ERADICATED AND RELOCATED AS DICTATED BY PROPOSED RAMP LOCATIONS. COST NOT INCIDENTAL TO COST OF PROPOSED RAMP.

CURB RAMP WIDTH SHALL MATCH SIDEWALK WIDTH PLUS CLEARANCE. TYPICAL SIDEWALK WIDTH IS 5' MINIMUM. RAMP WIDTHS LESS THAN 5' REQUIRE DIVISION/DISTRICT ENGINEER APPROVAL. WIDTHS LESS THAN 4' REQUIRE AN EXCEPTION JUSTIFICATION REPORT. SEE SHEET 11 FOR INFORMATION REGARDING RAMP THICKNESS.

GRADE BREAKS SHALL BE PERPENDICULAR TO THE DIRECTION OF THE RAMP RUN. SURFACE SLOPES THAT MEET AT GRADE BREAKS SHALL BE FLUSH.

CLEAR SPACE- BEYOND THE BOTTOM GRADE BREAK, A CLEAR SPACE THE WIDTH OF THE CURB RAMP AND EXTENDING 4' MINIMUM INTO THE ABUTTING ROADWAY SHALL BE PROVIDED WITHIN THE WIDTH OF THE PEDESTRIAN STREET CROSSING AND WHOLLY OUTSIDE THE PARALLEL TRAVEL LANE. SURFACE TO MATCH EXISTING. ANY CLEAR SPACE WORK TO BE COMPLETED WILL BE INCIDENTAL TO THE COST OF THE RAMP.

ALL CURB RAMPS SHALL BE CONSTRUCTED TO PROVIDE ACCESS TO EXISTING OPERABLE PARTS. AN EXAMPLE OF THIS WOULD BE PEDESTRIAN PUSH BUTTONS.

NOT TO SCALE

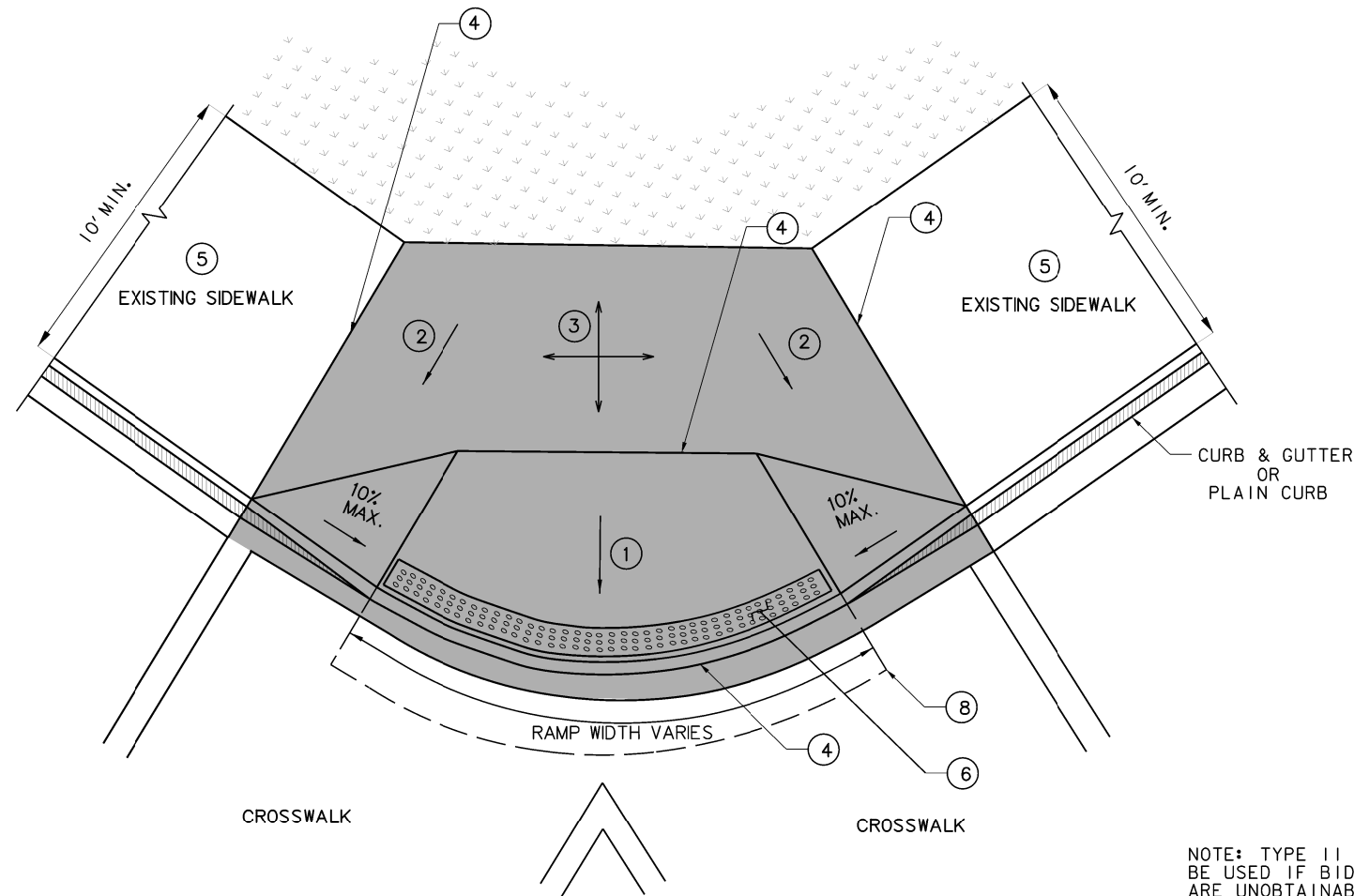

TYPE II RAMP

NOTE: TYPE II RAMPS ARE ONLY TO BE USED IF BIDIRECTIONAL RAMPS ARE UNOBTAINABLE DUE TO PHYSICAL CONSTRAINTS AND THE PEDESTRIAN ACCESS ROUTE (PAR) IS GREATER THAN (>) 10' WIDE FROM BACK OF CURB TO BACK OF SIDEWALK.

LEGEND

- ① 8.33% (12:1) MAXIMUM RAMP SLOPE INCLUDING CONSTRUCTION TOLERANCE SLOPE OF RAMP SHALL CARRY THROUGH TO FACE OF CURB
- ② CROSS SLOPE: 2.00% MAXIMUM INCLUDING CONSTRUCTION TOLERANCE
- ③ CURB RAMPS REQUIRE A (5'-0") MINIMUM TURNING SPACE WHERE PEDESTRIANS PERFORM TURNING MANEUVERS WITH A MAXIMUM CROSS SLOPE OF 2% AND LONGITUDINAL SLOPE MATCHING ROADWAY
- ④ GRADE BREAK REQUIRED TO BE FLUSH (0") AND PERPENDICULAR TO PEDESTRIAN PATH OF TRAVEL
- ⑤ IF SIDEWALK IS EXISTING AND NON-COMPLIANT SEE "TRANSITION TO EXISTING NON-COMPLIANT SIDEWALK" DETAIL SHEET 12
- ⑥ DETECTABLE WARNING SURFACE SEE "DETECTABLE WARNING SURFACE (DWS)" DETAIL SHEET 11
- ⑦ CURB WALL OR CHEEK WALL AS DICTATED BY FIELD CONDITIONS. SEE "EXISTING ADJACENT SURFACE TRANSITION" DETAIL SHEET 13
- ⑧ CLEAR SPACE - WIDTH OF CURB RAMP AND EXTENDING 4' MINIMUM
- ⑨ 3/4" CHAMFER EDGE

PAY LIMITS FOR CURB RAMPS (EXCLUDING DWS)

**WEST VIRGINIA DEPARTMENT OF TRANSPORTATION
DIVISION OF HIGHWAYS
STANDARD DETAIL**

PREPARED 1-1-1999

REVISION DATE
7/21/10
10/22/13
10/01/20

SIDEWALK RAMPS

(Sheet 4 of 13)

TYPE II RAMP

STANDARD SHEET PVT 7

NOTES

THE TYPE OF RAMP TO BE USED SHALL BE AS SPECIFIED ON THE PLANS. THESE STANDARDS CAN BE CONSIDERED GUIDELINES IN SELECTING RAMP TYPES, HOWEVER THEY CAN BE DEVIATED FROM WITH A SPECIAL DETAIL AS NOTED IN PLANS.

RAMP CONCRETE SHALL MEET THE REQUIREMENTS OF SECTION 609 OF THE CURRENT WVDOT, DOH STANDARD SPECIFICATIONS ROADS AND BRIDGES AND ANY SUBSEQUENT DOH SUPPLEMENTAL SPECIFICATIONS, AND THE PUBLIC RIGHTS OF WAY ACCESSIBILITY GUIDELINES (PROWAG) DATED JULY 26, 2011. RAMP SURFACE SHALL INCLUDE A "DETECTABLE WARNING SURFACE" (SEE PVT 7 SHT. 11 OF 13) AS SHOWN FOR EACH RAMP TYPE. A COARSE BROOM FINISH, TRANSVERSE TO FLARE SLOPES, OR EQUAL NON-SKID FINISH SHALL BE PROVIDED ON CONCRETE SURFACES.

NORMAL GUTTER FLOW LINE AND PROFILE SHALL BE MAINTAINED THROUGH THE RAMP AREA, UNLESS OTHERWISE SHOWN OR SPECIFIED. POSITIVE DRAINAGE MUST BE MAINTAINED SO THAT NO PONDING OCCURS WITHIN THE RAMP OR CLEAR SPACE AREA.

1/4" MINIMUM, 1/2" MAXIMUM PREFORMED EXPANSION JOINT FILLER, MEETING THE REQUIREMENTS OF SECTION 609 OF THE SPECIFICATIONS, AS NOTED ABOVE, SHALL BE PLACED AT ALL LOCATIONS WHERE RAMP CONTACTS CURB, GUTTER, CONCRETE PAVEMENT, OR OTHER RIGID OBJECTS.

WHERE EXISTING SIDEWALK CONNECTS TO PROPOSED SIDEWALK OR RAMPS, EXPANSION JOINTS ALONG WITH DOWEL BARS WILL BE PLACED. DOWEL BARS WILL BE UTILIZED BETWEEN EXISTING AND PROPOSED TO REDUCE VERTICAL CHANGE. SEE SHEET 11 FOR ADDITIONAL INFORMATION.

SAWCUTS WILL BE UTILIZED DURING DEMOLITION OF EXISTING SIDEWALKS. SIMILAR METHODS MAY BE USED UPON APPROVAL BY FIELD ENGINEER.

RAMPS SHALL NOT BE PLACED IN LINE WITH DRAINAGE STRUCTURES. LOCATION OF THE RAMP SHALL TAKE PRECEDENCE OVER LOCATION OF THE DRAINAGE STRUCTURE, EXCEPT WHERE EXISTING STRUCTURES ARE BEING UTILIZED FOR CONSTRUCTION OF NEW RAMPS.

ANY GRATE IN PEDESTRIAN AREAS SHALL HAVE OPENINGS NOT GREATER THAN 1/2" AND SHALL BE PLACED WITH LONG DIMENSION OF OPENING PERPENDICULAR TO THE DIRECTION OF PEDESTRIAN TRAVEL.

IF THE 8.33% (12:1) SLOPE CANNOT BE OBTAINED DUE TO GRADE OF THE ADJACENT ROADWAY, THE SLOPED PORTION OF THE RAMP SHALL BE EXTENDED TO A MINIMUM LENGTH OF 15'-0".

EXISTING CROSS WALK AND STOP BAR MARKINGS TO BE ERADICATED AND RELOCATED AS DICTATED BY PROPOSED RAMP LOCATIONS. COST NOT INCIDENTAL TO COST OF PROPOSED RAMP.

CURB RAMP WIDTH SHALL MATCH SIDEWALK WIDTH PLUS CLEARANCE. TYPICAL SIDEWALK WIDTH IS 5' MINIMUM. RAMP WIDTHS LESS THAN 5' REQUIRE DIVISION/DISTRICT ENGINEER APPROVAL. WIDTHS LESS THAN 4' REQUIRE AN EXCEPTION JUSTIFICATION REPORT. SEE SHEET 11 FOR INFORMATION REGARDING RAMP THICKNESS.

GRADE BREAKS SHALL BE PERPENDICULAR TO THE DIRECTION OF THE RAMP RUN. SURFACE SLOPES THAT MEET AT GRADE BREAKS SHALL BE FLUSH.

CLEAR SPACE- BEYOND THE BOTTOM GRADE BREAK, A CLEAR SPACE THE WIDTH OF THE CURB RAMP AND EXTENDING 4' MINIMUM INTO THE ABUTTING ROADWAY SHALL BE PROVIDED WITHIN THE WIDTH OF THE PEDESTRIAN STREET CROSSING AND WHOLLY OUTSIDE THE PARALLEL TRAVEL LANE. SURFACE TO MATCH EXISTING. ANY CLEAR SPACE WORK TO BE COMPLETED WILL BE INCIDENTAL TO THE COST OF THE RAMP.

ALL CURB RAMPS SHALL BE CONSTRUCTED TO PROVIDE ACCESS TO EXISTING OPERABLE PARTS. AN EXAMPLE OF THIS WOULD BE PEDESTRIAN PUSH BUTTONS.

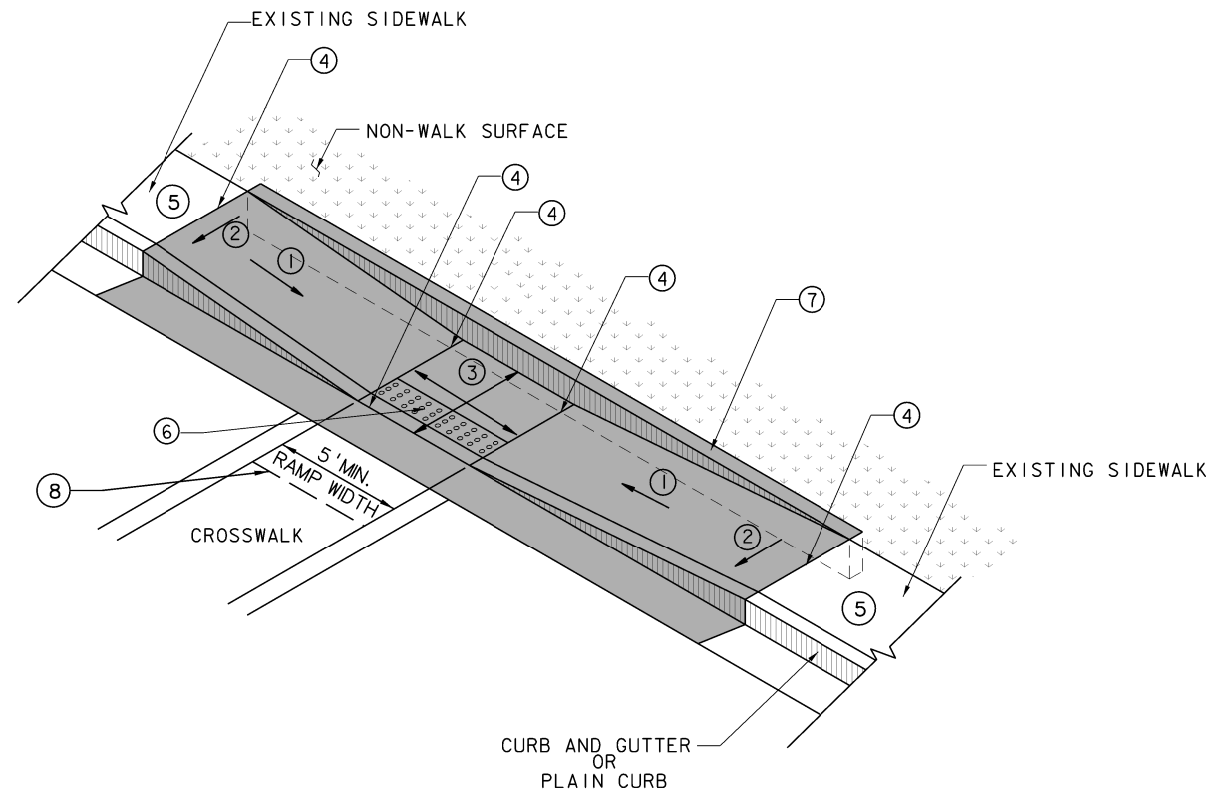

TYPE III RAMP

LEGEND

- ① 8.33% (12:1) MAXIMUM RAMP SLOPE INCLUDING CONSTRUCTION TOLERANCE
SLOPE OF RAMP SHALL CARRY THROUGH TO FACE OF CURB
- ② CROSS SLOPE: 2.00% MAXIMUM INCLUDING CONSTRUCTION TOLERANCE
- ③ CURB RAMPS REQUIRE A (5'-0") MINIMUM TURNING SPACE WHERE PEDESTRIANS PERFORM TURNING MANEUVERS WITH A MAXIMUM CROSS SLOPE OF 2% AND LONGITUDINAL SLOPE MATCHING ROADWAY
- ④ GRADE BREAK REQUIRED TO BE FLUSH (0") AND PERPENDICULAR TO PEDESTRIAN PATH OF TRAVEL
- ⑤ IF SIDEWALK IS EXISTING AND NON-COMPLIANT SEE "TRANSITION TO EXISTING NON-COMPLIANT SIDEWALK" DETAIL SHEET 12
- ⑥ DETECTABLE WARNING SURFACE
SEE "DETECTABLE WARNING SURFACE (DWS)" DETAIL SHEET 11
- ⑦ CURB WALL OR CHEEK WALL AS DICTATED BY FIELD CONDITIONS. SEE "EXISTING ADJACENT SURFACE TRANSITION" DETAIL SHEET 13
- ⑧ CLEAR SPACE - WIDTH OF CURB RAMP AND EXTENDING 4' MINIMUM
- ⑨ 3/4" CHAMFER EDGE

 PAY LIMITS FOR CURB RAMPS (EXCLUDING DWS)

NOT TO SCALE

**WEST VIRGINIA DEPARTMENT OF TRANSPORTATION
DIVISION OF HIGHWAYS
STANDARD DETAIL**

PREPARED 1-1-1999
REVISION DATE
7/21/10
10/22/13
10/01/20

**SIDEWALK RAMPS
(Sheet 5 of 13)
TYPE III RAMP**

STANDARD SHEET PVT 7

NOTES

THE TYPE OF RAMP TO BE USED SHALL BE AS SPECIFIED ON THE PLANS. THESE STANDARDS CAN BE CONSIDERED GUIDELINES IN SELECTING RAMP TYPES, HOWEVER THEY CAN BE DEVIATED FROM WITH A SPECIAL DETAIL AS NOTED IN PLANS.

RAMP CONCRETE SHALL MEET THE REQUIREMENTS OF SECTION 609 OF THE CURRENT WVDOT, DOH STANDARD SPECIFICATIONS ROADS AND BRIDGES AND ANY SUBSEQUENT DOH SUPPLEMENTAL SPECIFICATIONS, AND THE PUBLIC RIGHTS OF WAY ACCESSIBILITY GUIDELINES (PROWAG) DATED JULY 26, 2011. RAMP SURFACE SHALL INCLUDE A "DETECTABLE WARNING SURFACE" (SEE PVT 7 SHT. 11 OF 13) AS SHOWN FOR EACH RAMP TYPE. A COARSE BROOM FINISH, TRANSVERSE TO FLARE SLOPES, OR EQUAL NON-SKID FINISH SHALL BE PROVIDED ON CONCRETE SURFACES.

NORMAL GUTTER FLOW LINE AND PROFILE SHALL BE MAINTAINED THROUGH THE RAMP AREA, UNLESS OTHERWISE SHOWN OR SPECIFIED. POSITIVE DRAINAGE MUST BE MAINTAINED SO THAT NO PONDING OCCURS WITHIN THE RAMP OR CLEAR SPACE AREA.

1/4" MINIMUM, 1/2" MAXIMUM PREFORMED EXPANSION JOINT FILLER, MEETING THE REQUIREMENTS OF SECTION 609 OF THE SPECIFICATIONS, AS NOTED ABOVE, SHALL BE PLACED AT ALL LOCATIONS WHERE RAMP CONTACTS CURB, GUTTER, CONCRETE PAVEMENT, OR OTHER RIGID OBJECTS.

WHERE EXISTING SIDEWALK CONNECTS TO PROPOSED SIDEWALK OR RAMPS, EXPANSION JOINTS ALONG WITH DOWEL BARS WILL BE PLACED. DOWEL BARS WILL BE UTILIZED BETWEEN EXISTING AND PROPOSED TO REDUCE VERTICAL CHANGE. SEE SHEET 11 FOR ADDITIONAL INFORMATION.

SAWCUTS WILL BE UTILIZED DURING DEMOLITION OF EXISTING SIDEWALKS. SIMILAR METHODS MAY BE USED UPON APPROVAL BY FIELD ENGINEER.

RAMPS SHALL NOT BE PLACED IN LINE WITH DRAINAGE STRUCTURES. LOCATION OF THE RAMP SHALL TAKE PRECEDENCE OVER LOCATION OF THE DRAINAGE STRUCTURE, EXCEPT WHERE EXISTING STRUCTURES ARE BEING UTILIZED FOR CONSTRUCTION OF NEW RAMPS.

ANY GRATE IN PEDESTRIAN AREAS SHALL HAVE OPENINGS NOT GREATER THAN 1/2" AND SHALL BE PLACED WITH LONG DIMENSION OF OPENING PERPENDICULAR TO THE DIRECTION OF PEDESTRIAN TRAVEL.

IF THE 8.33% (12:1) SLOPE CANNOT BE OBTAINED DUE TO GRADE OF THE ADJACENT ROADWAY, THE SLOPED PORTION OF THE RAMP SHALL BE EXTENDED TO A MINIMUM LENGTH OF 15'-0".

EXISTING CROSS WALK AND STOP BAR MARKINGS TO BE ERADICATED AND RELOCATED AS DICTATED BY PROPOSED RAMP LOCATIONS. COST NOT INCIDENTAL TO COST OF PROPOSED RAMP.

CURB RAMP WIDTH SHALL MATCH SIDEWALK WIDTH PLUS CLEARANCE. TYPICAL SIDEWALK WIDTH IS 5' MINIMUM. RAMP WIDTHS LESS THAN 5' REQUIRE DIVISION/DISTRICT ENGINEER APPROVAL. WIDTHS LESS THAN 4' REQUIRE AN EXCEPTION JUSTIFICATION REPORT. SEE SHEET 11 FOR INFORMATION REGARDING RAMP THICKNESS.

GRADE BREAKS SHALL BE PERPENDICULAR TO THE DIRECTION OF THE RAMP RUN. SURFACE SLOPES THAT MEET AT GRADE BREAKS SHALL BE FLUSH.

CLEAR SPACE- BEYOND THE BOTTOM GRADE BREAK, A CLEAR SPACE THE WIDTH OF THE CURB RAMP AND EXTENDING 4' MINIMUM INTO THE ABUTTING ROADWAY SHALL BE PROVIDED WITHIN THE WIDTH OF THE PEDESTRIAN STREET CROSSING AND WHOLLY OUTSIDE THE PARALLEL TRAVEL LANE. SURFACE TO MATCH EXISTING. ANY CLEAR SPACE WORK TO BE COMPLETED WILL BE INCIDENTAL TO THE COST OF THE RAMP.

ALL CURB RAMPS SHALL BE CONSTRUCTED TO PROVIDE ACCESS TO EXISTING OPERABLE PARTS. AN EXAMPLE OF THIS WOULD BE PEDESTRIAN PUSH BUTTONS.

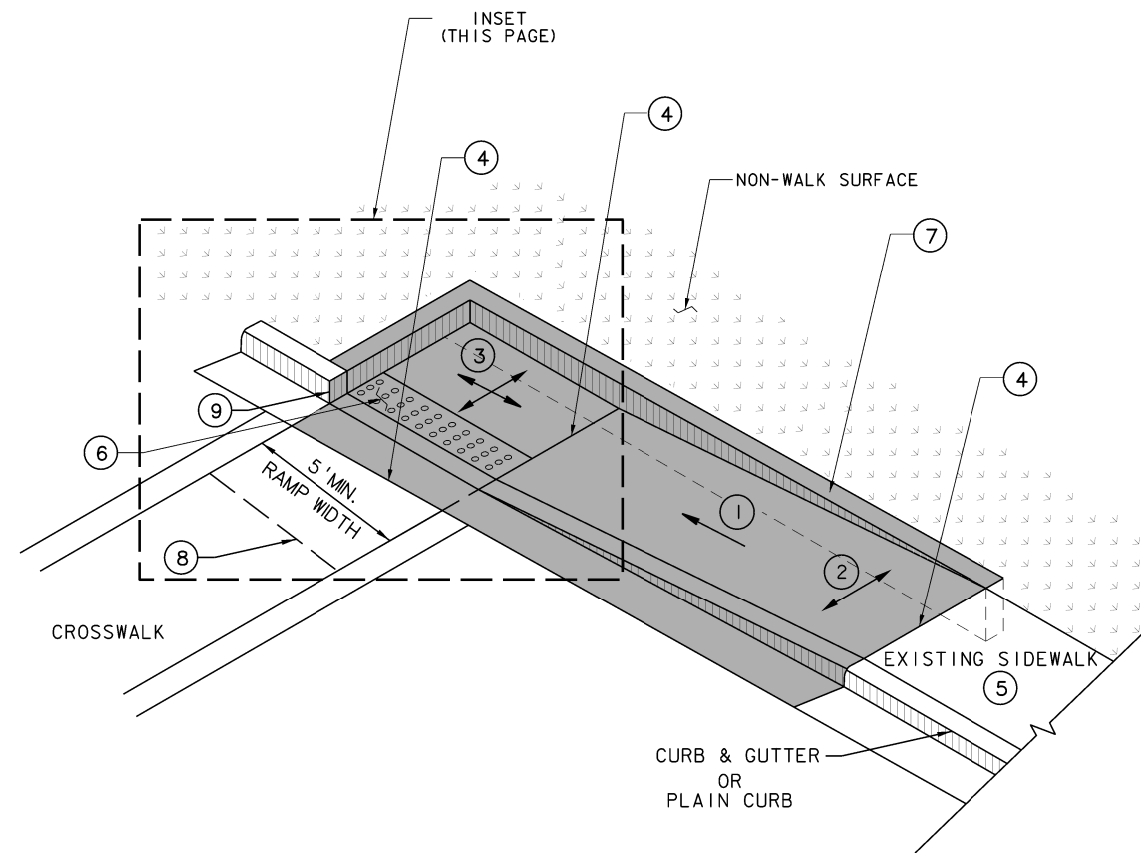

TYPE IIIA - OPTION 1

END OF SIDEWALK
PREFERRED OPTION

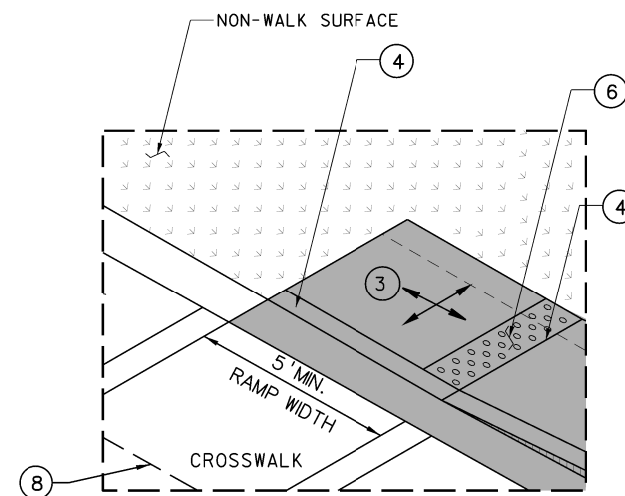

TYPE IIIA - OPTION 2

END OF SIDEWALK
ALTERNATE OPTION
(WITHOUT CURB OR
CHEEK WALL)

LEGEND

- ① 8.33% (12:1) MAXIMUM RAMP SLOPE INCLUDING CONSTRUCTION TOLERANCE
SLOPE OF RAMP SHALL CARRY THROUGH TO FACE OF CURB
- ② CROSS SLOPE: 2.00% MAXIMUM INCLUDING CONSTRUCTION TOLERANCE
- ③ CURB RAMPS REQUIRE A (5'-0") MINIMUM TURNING SPACE WHERE PEDESTRIANS
PERFORM TURNING MANEUVERS WITH A MAXIMUM CROSS SLOPE OF 2% AND
LONGITUDINAL SLOPE MATCHING ROADWAY
- ④ GRADE BREAK REQUIRED TO BE FLUSH (0") AND PERPENDICULAR TO
PEDESTRIAN PATH OF TRAVEL
- ⑤ IF SIDEWALK IS EXISTING AND NON-COMPLIANT SEE "TRANSITION
TO EXISTING NON-COMPLIANT SIDEWALK" DETAIL SHEET 12
- ⑥ DETECTABLE WARNING SURFACE
SEE "DETECTABLE WARNING SURFACE (DWS)" DETAIL SHEET 11
- ⑦ CURB WALL OR CHEEK WALL AS DICTATED BY FIELD
CONDITIONS. SEE "EXISTING ADJACENT SURFACE TRANSITION"
DETAIL SHEET 13
- ⑧ CLEAR SPACE - WIDTH OF CURB RAMP AND EXTENDING 4'
MINIMUM
- ⑨ 3/4" CHAMFER EDGE

PAY LIMITS FOR CURB RAMPS
(EXCLUDING DWS)

NOT TO SCALE

SHEET 1 OF 2

**WEST VIRGINIA DEPARTMENT OF TRANSPORTATION
DIVISION OF HIGHWAYS
STANDARD DETAIL**

PREPARED 1-1-1999
REVISION DATE
7/21/10
10/22/13
10/01/20

**SIDEWALK RAMPS
(Sheet 6 of 13)
TYPE IIIA RAMP**

STANDARD SHEET PVT 7

NOTES

THE TYPE OF RAMP TO BE USED SHALL BE AS SPECIFIED ON THE PLANS. THESE STANDARDS CAN BE CONSIDERED GUIDELINES IN SELECTING RAMP TYPES, HOWEVER THEY CAN BE DEVIATED FROM WITH A SPECIAL DETAIL AS NOTED IN PLANS.

RAMP CONCRETE SHALL MEET THE REQUIREMENTS OF SECTION 609 OF THE CURRENT WVDOT, DOH STANDARD SPECIFICATIONS ROADS AND BRIDGES AND ANY SUBSEQUENT DOH SUPPLEMENTAL SPECIFICATIONS, AND THE PUBLIC RIGHTS OF WAY ACCESSIBILITY GUIDELINES (PROWAG) DATED JULY 26, 2011. RAMP SURFACE SHALL INCLUDE A "DETECTABLE WARNING SURFACE" (SEE PVT7 SHT. 11 OF 13) AS SHOWN FOR EACH RAMP TYPE. A COARSE BROOM FINISH, TRANSVERSE TO FLARE SLOPES, OR EQUAL NON-SKID FINISH SHALL BE PROVIDED ON CONCRETE SURFACES.

NORMAL GUTTER FLOW LINE AND PROFILE SHALL BE MAINTAINED THROUGH THE RAMP AREA, UNLESS OTHERWISE SHOWN OR SPECIFIED. POSITIVE DRAINAGE MUST BE MAINTAINED SO THAT NO PONDING OCCURS WITHIN THE RAMP OR CLEAR SPACE AREA.

1/4" MINIMUM, 1/2" MAXIMUM PREFORMED EXPANSION JOINT FILLER, MEETING THE REQUIREMENTS OF SECTION 609 OF THE SPECIFICATIONS, AS NOTED ABOVE, SHALL BE PLACED AT ALL LOCATIONS WHERE RAMP CONTACTS CURB, GUTTER, CONCRETE PAVEMENT, OR OTHER RIGID OBJECTS.

WHERE EXISTING SIDEWALK CONNECTS TO PROPOSED SIDEWALK OR RAMPS, EXPANSION JOINTS ALONG WITH DOWEL BARS WILL BE PLACED. DOWEL BARS WILL BE UTILIZED BETWEEN EXISTING AND PROPOSED TO REDUCE VERTICAL CHANGE. SEE SHEET 11 FOR ADDITIONAL INFORMATION.

SAWCUTS WILL BE UTILIZED DURING DEMOLITION OF EXISTING SIDEWALKS. SIMILAR METHODS MAY BE USED UPON APPROVAL BY FIELD ENGINEER.

RAMPS SHALL NOT BE PLACED IN LINE WITH DRAINAGE STRUCTURES. LOCATION OF THE RAMP SHALL TAKE PRECEDENCE OVER LOCATION OF THE DRAINAGE STRUCTURE, EXCEPT WHERE EXISTING STRUCTURES ARE BEING UTILIZED FOR CONSTRUCTION OF NEW RAMPS.

ANY GRATE IN PEDESTRIAN AREAS SHALL HAVE OPENINGS NOT GREATER THAN 1/2" AND SHALL BE PLACED WITH LONG DIMENSION OF OPENING PERPENDICULAR TO THE DIRECTION OF PEDESTRIAN TRAVEL.

IF THE 8.33% (12:1) SLOPE CANNOT BE OBTAINED DUE TO GRADE OF THE ADJACENT ROADWAY, THE SLOPED PORTION OF THE RAMP SHALL BE EXTENDED TO A MINIMUM LENGTH OF 15'-0".

EXISTING CROSS WALK AND STOP BAR MARKINGS TO BE ERADICATED AND RELOCATED AS DICTATED BY PROPOSED RAMP LOCATIONS. COST NOT INCIDENTAL TO COST OF PROPOSED RAMP.

CURB RAMP WIDTH SHALL MATCH SIDEWALK WIDTH PLUS CLEARANCE. TYPICAL SIDEWALK WIDTH IS 5' MINIMUM. RAMP WIDTHS LESS THAN 5' REQUIRE DIVISION/DISTRICT ENGINEER APPROVAL. WIDTHS LESS THAN 4' REQUIRE AN EXCEPTION JUSTIFICATION REPORT. SEE SHEET 11 FOR INFORMATION REGARDING RAMP THICKNESS.

GRADE BREAKS SHALL BE PERPENDICULAR TO THE DIRECTION OF THE RAMP RUN. SURFACE SLOPES THAT MEET AT GRADE BREAKS SHALL BE FLUSH.

CLEAR SPACE- BEYOND THE BOTTOM GRADE BREAK, A CLEAR SPACE THE WIDTH OF THE CURB RAMP AND EXTENDING 4' MINIMUM INTO THE ABUTTING ROADWAY SHALL BE PROVIDED WITHIN THE WIDTH OF THE PEDESTRIAN STREET CROSSING AND WHOLLY OUTSIDE THE PARALLEL TRAVEL LANE. SURFACE TO MATCH EXISTING. ANY CLEAR SPACE WORK TO BE COMPLETED WILL BE INCIDENTAL TO THE COST OF THE RAMP.

ALL CURB RAMPS SHALL BE CONSTRUCTED TO PROVIDE ACCESS TO EXISTING OPERABLE PARTS. AN EXAMPLE OF THIS WOULD BE PEDESTRIAN PUSH BUTTONS.

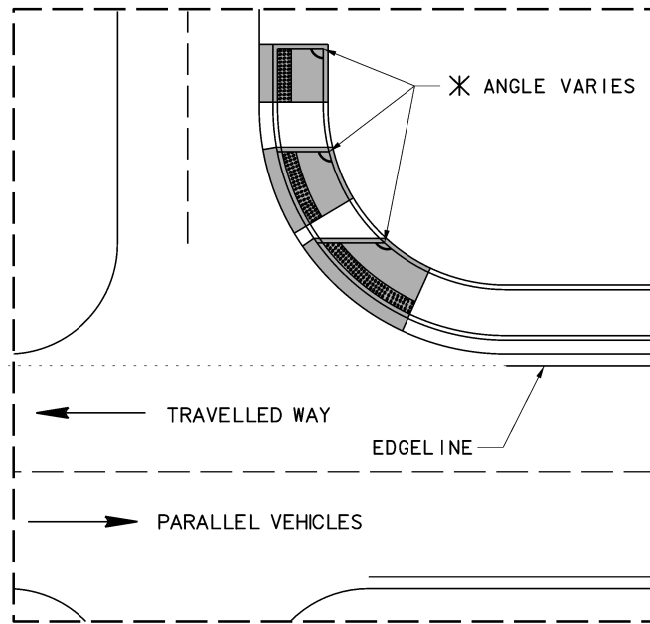

* LOCATIONS NOTED ARE EXAMPLES ONLY. CURB RAMP CAN BE LOCATED AT ANY POINT ALONG RADIUS OF SIDEWALK AS DETERMINED BY FIELD CONDITIONS. WIDTH AT CURB DEPENDENT ON ANGLE.

TYPE IIIA - OPTION 3

EXAMPLE OF RAMP LOCATION ALONG RADIUS

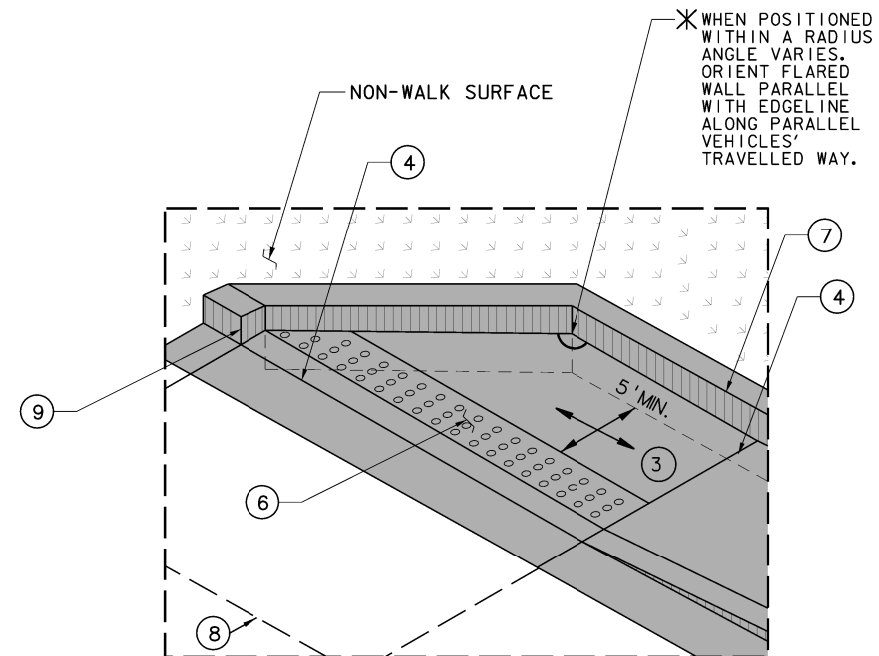

TYPE IIIA - OPTION 3

END OF SIDEWALK
PREFERRED OPTION
(LARGER CURB ANGLE)

LEGEND

- ① 8.33% (12:1) MAXIMUM RAMP SLOPE INCLUDING CONSTRUCTION TOLERANCE SLOPE OF RAMP SHALL CARRY THROUGH TO FACE OF CURB
- ② CROSS SLOPE: 2.00% MAXIMUM INCLUDING CONSTRUCTION TOLERANCE
- ③ CURB RAMPS REQUIRE A (5'-0") MINIMUM TURNING SPACE WHERE PEDESTRIANS PERFORM TURNING MANEUVERS WITH A MAXIMUM CROSS SLOPE OF 2% AND LONGITUDINAL SLOPE MATCHING ROADWAY
- ④ GRADE BREAK REQUIRED TO BE FLUSH (0") AND PERPENDICULAR TO PEDESTRIAN PATH OF TRAVEL
- ⑤ IF SIDEWALK IS EXISTING AND NON-COMPLIANT SEE "TRANSITION TO EXISTING NON-COMPLIANT SIDEWALK" DETAIL SHEET 12
- ⑥ DETECTABLE WARNING SURFACE SEE "DETECTABLE WARNING SURFACE (DWS)" DETAIL SHEET 11
- ⑦ CURB WALL OR CHEEK WALL AS DICTATED BY FIELD CONDITIONS. SEE "EXISTING ADJACENT SURFACE TRANSITION" DETAIL SHEET 13
- ⑧ CLEAR SPACE - WIDTH OF CURB RAMP AND EXTENDING 4' MINIMUM
- ⑨ 3/4" CHAMFER EDGE

PAY LIMITS FOR CURB RAMPS (EXCLUDING DWS)

NOT TO SCALE

SHEET 2 OF 2

**WEST VIRGINIA DEPARTMENT OF TRANSPORTATION
DIVISION OF HIGHWAYS
STANDARD DETAIL**

PREPARED 1-1-1999

REVISION DATE
7/21/10
10/22/13
10/01/20

SIDEWALK RAMPS

(Sheet 7 of 13)

TYPE IIIA RAMP

STANDARD SHEET PVT 7

NOTES

THE TYPE OF RAMP TO BE USED SHALL BE AS SPECIFIED ON THE PLANS. THESE STANDARDS CAN BE CONSIDERED GUIDELINES IN SELECTING RAMP TYPES, HOWEVER THEY CAN BE DEVIATED FROM WITH A SPECIAL DETAIL AS NOTED IN PLANS.

RAMP CONCRETE SHALL MEET THE REQUIREMENTS OF SECTION 609 OF THE CURRENT WVDOT, DOH STANDARD SPECIFICATIONS ROADS AND BRIDGES AND ANY SUBSEQUENT DOH SUPPLEMENTAL SPECIFICATIONS, AND THE PUBLIC RIGHTS OF WAY ACCESSIBILITY GUIDELINES (PROWAG) DATED JULY 26, 2011. RAMP SURFACE SHALL INCLUDE A "DETECTABLE WARNING SURFACE" (SEE PVT 7 SHT. 11 OF 13) AS SHOWN FOR EACH RAMP TYPE. A COARSE BROOM FINISH, TRANSVERSE TO FLARE SLOPES, OR EQUAL NON-SKID FINISH SHALL BE PROVIDED ON CONCRETE SURFACES.

NORMAL GUTTER FLOW LINE AND PROFILE SHALL BE MAINTAINED THROUGH THE RAMP AREA, UNLESS OTHERWISE SHOWN OR SPECIFIED. POSITIVE DRAINAGE MUST BE MAINTAINED SO THAT NO PONDING OCCURS WITHIN THE RAMP OR CLEAR SPACE AREA.

1/4" MINIMUM, 1/2" MAXIMUM PREFORMED EXPANSION JOINT FILLER, MEETING THE REQUIREMENTS OF SECTION 609 OF THE SPECIFICATIONS, AS NOTED ABOVE, SHALL BE PLACED AT ALL LOCATIONS WHERE RAMP CONTACTS CURB, GUTTER, CONCRETE PAVEMENT, OR OTHER RIGID OBJECTS.

WHERE EXISTING SIDEWALK CONNECTS TO PROPOSED SIDEWALK OR RAMPS, EXPANSION JOINTS ALONG WITH DOWEL BARS WILL BE PLACED. DOWEL BARS WILL BE UTILIZED BETWEEN EXISTING AND PROPOSED TO REDUCE VERTICAL CHANGE. SEE SHEET 11 FOR ADDITIONAL INFORMATION.

SAWCUTS WILL BE UTILIZED DURING DEMOLITION OF EXISTING SIDEWALKS. SIMILAR METHODS MAY BE USED UPON APPROVAL BY FIELD ENGINEER.

RAMPS SHALL NOT BE PLACED IN LINE WITH DRAINAGE STRUCTURES. LOCATION OF THE RAMP SHALL TAKE PRECEDENCE OVER LOCATION OF THE DRAINAGE STRUCTURE, EXCEPT WHERE EXISTING STRUCTURES ARE BEING UTILIZED FOR CONSTRUCTION OF NEW RAMPS.

ANY GRATE IN PEDESTRIAN AREAS SHALL HAVE OPENINGS NOT GREATER THAN 1/2" AND SHALL BE PLACED WITH LONG DIMENSION OF OPENING PERPENDICULAR TO THE DIRECTION OF PEDESTRIAN TRAVEL.

IF THE 8.33% (12:1) SLOPE CANNOT BE OBTAINED DUE TO GRADE OF THE ADJACENT ROADWAY, THE SLOPED PORTION OF THE RAMP SHALL BE EXTENDED TO A MINIMUM LENGTH OF 15'-0".

EXISTING CROSS WALK AND STOP BAR MARKINGS TO BE ERADICATED AND RELOCATED AS DICTATED BY PROPOSED RAMP LOCATIONS. COST NOT INCIDENTAL TO COST OF PROPOSED RAMP.

CURB RAMP WIDTH SHALL MATCH SIDEWALK WIDTH PLUS CLEARANCE. TYPICAL SIDEWALK WIDTH IS 5' MINIMUM. RAMP WIDTHS LESS THAN 5' REQUIRE DIVISION/DISTRICT ENGINEER APPROVAL. WIDTHS LESS THAN 4' REQUIRE AN EXCEPTION JUSTIFICATION REPORT. SEE SHEET 11 FOR INFORMATION REGARDING RAMP THICKNESS.

GRADE BREAKS SHALL BE PERPENDICULAR TO THE DIRECTION OF THE RAMP RUN. SURFACE SLOPES THAT MEET AT GRADE BREAKS SHALL BE FLUSH.

CLEAR SPACE- BEYOND THE BOTTOM GRADE BREAK, A CLEAR SPACE THE WIDTH OF THE CURB RAMP AND EXTENDING 4' MINIMUM INTO THE ABUTTING ROADWAY SHALL BE PROVIDED WITHIN THE WIDTH OF THE PEDESTRIAN STREET CROSSING AND WHOLLY OUTSIDE THE PARALLEL TRAVEL LANE. SURFACE TO MATCH EXISTING. ANY CLEAR SPACE WORK TO BE COMPLETED WILL BE INCIDENTAL TO THE COST OF THE RAMP.

ALL CURB RAMPS SHALL BE CONSTRUCTED TO PROVIDE ACCESS TO EXISTING OPERABLE PARTS. AN EXAMPLE OF THIS WOULD BE PEDESTRIAN PUSH BUTTONS.

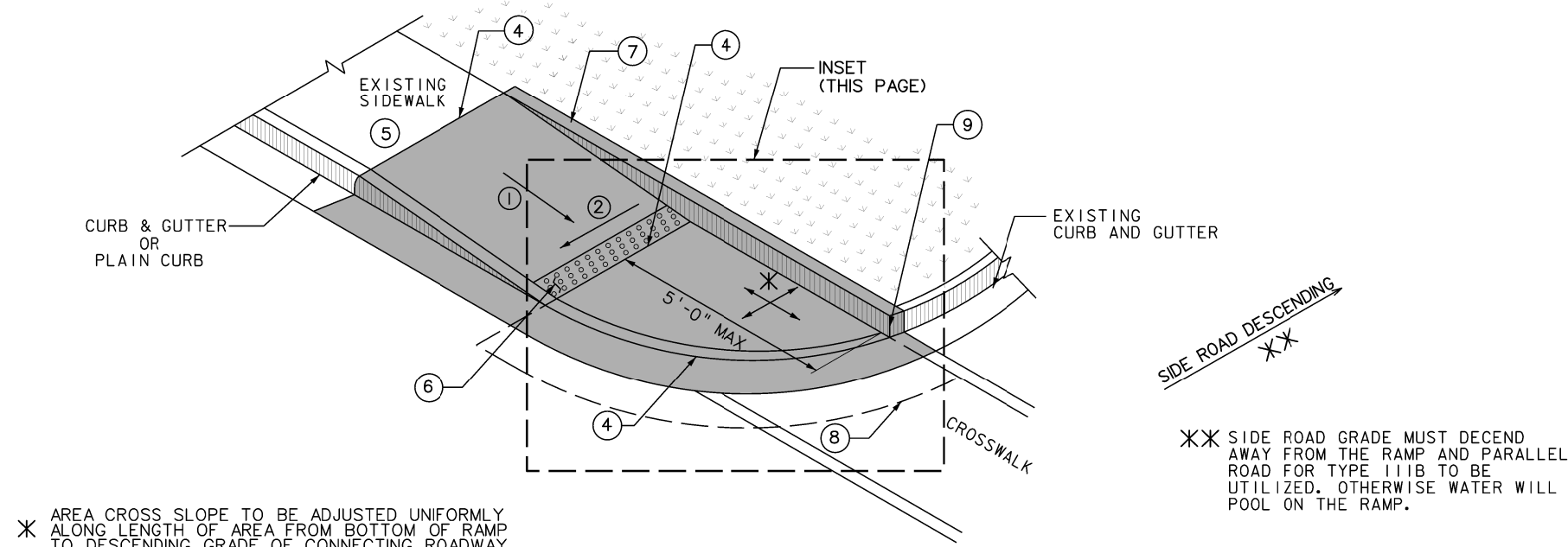

* AREA CROSS SLOPE TO BE ADJUSTED UNIFORMLY ALONG LENGTH OF AREA FROM BOTTOM OF RAMP TO DESCENDING GRADE OF CONNECTING ROADWAY.

SIDE ROAD DESCENDING

** SIDE ROAD GRADE MUST DECEND AWAY FROM THE RAMP AND PARALLEL ROAD FOR TYPE III B TO BE UTILIZED. OTHERWISE WATER WILL POOL ON THE RAMP.

TYPE III B

(DESCENDING SIDE ROAD ONLY)

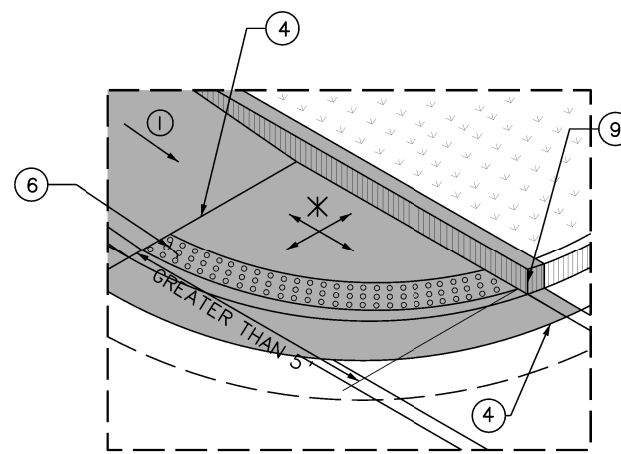

TYPE III B (INSET)

LEGEND

- ① 8.33% (12:1) MAXIMUM RAMP SLOPE INCLUDING CONSTRUCTION TOLERANCE. SLOPE OF RAMP SHALL CARRY THROUGH TO FACE OF CURB
- ② CROSS SLOPE: 2.00% MAXIMUM INCLUDING CONSTRUCTION TOLERANCE
- ③ CURB RAMPS REQUIRE A (5'-0") MINIMUM TURNING SPACE WHERE PEDESTRIANS PERFORM TURNING MANEUVERS WITH A MAXIMUM CROSS SLOPE OF 2% AND LONGITUDINAL SLOPE MATCHING ROADWAY
- ④ GRADE BREAK REQUIRED TO BE FLUSH (0") AND PERPENDICULAR TO PEDESTRIAN PATH OF TRAVEL
- ⑤ IF SIDEWALK IS EXISTING AND NON-COMPLIANT SEE "TRANSITION TO EXISTING NON-COMPLIANT SIDEWALK" DETAIL SHEET 12
- ⑥ DETECTABLE WARNING SURFACE SEE "DETECTABLE WARNING SURFACE (DWS)" DETAIL SHEET 11
- ⑦ CURB WALL OR CHEEK WALL AS DICTATED BY FIELD CONDITIONS. SEE "EXISTING ADJACENT SURFACE TRANSITION" DETAIL SHEET 13
- ⑧ CLEAR SPACE - WIDTH OF CURB RAMP AND EXTENDING 4' MINIMUM
- ⑨ 3/4" CHAMFER EDGE

PAY LIMITS FOR CURB RAMPS (EXCLUDING DWS)

NOT TO SCALE

WEST VIRGINIA DEPARTMENT OF TRANSPORTATION
DIVISION OF HIGHWAYS
STANDARD DETAIL

PREPARED 1-1-1999
REVISION DATE
7/21/10
10/22/13
10/01/20

SIDEWALK RAMPS
(Sheet 8 of 13)
TYPE III B RAMP

STANDARD SHEET PVT 7

NOTES

THE TYPE OF RAMP TO BE USED SHALL BE AS SPECIFIED ON THE PLANS. THESE STANDARDS CAN BE CONSIDERED GUIDELINES IN SELECTING RAMP TYPES, HOWEVER THEY CAN BE DEVIATED FROM WITH A SPECIAL DETAIL AS NOTED IN PLANS.

RAMP CONCRETE SHALL MEET THE REQUIREMENTS OF SECTION 609 OF THE CURRENT WVDOT, DOH STANDARD SPECIFICATIONS ROADS AND BRIDGES AND ANY SUBSEQUENT DOH SUPPLEMENTAL SPECIFICATIONS, AND THE PUBLIC RIGHTS OF WAY ACCESSIBILITY GUIDELINES (PROWAG) DATED JULY 26, 2011. RAMP SURFACE SHALL INCLUDE A "DETECTABLE WARNING SURFACE" (SEE PVT7 SHT. 11 OF 13) AS SHOWN FOR EACH RAMP TYPE. A COARSE BROOM FINISH, TRANSVERSE TO FLARE SLOPES, OR EQUAL NON-SKID FINISH SHALL BE PROVIDED ON CONCRETE SURFACES.

NORMAL GUTTER FLOW LINE AND PROFILE SHALL BE MAINTAINED THROUGH THE RAMP AREA, UNLESS OTHERWISE SHOWN OR SPECIFIED. POSITIVE DRAINAGE MUST BE MAINTAINED SO THAT NO PONDING OCCURS WITHIN THE RAMP OR CLEAR SPACE AREA.

1/4" MINIMUM, 1/2" MAXIMUM PREFORMED EXPANSION JOINT FILLER, MEETING THE REQUIREMENTS OF SECTION 609 OF THE SPECIFICATIONS, AS NOTED ABOVE, SHALL BE PLACED AT ALL LOCATIONS WHERE RAMP CONTACTS CURB, GUTTER, CONCRETE PAVEMENT, OR OTHER RIGID OBJECTS.

WHERE EXISTING SIDEWALK CONNECTS TO PROPOSED SIDEWALK OR RAMPS, EXPANSION JOINTS ALONG WITH DOWEL BARS WILL BE PLACED. DOWEL BARS WILL BE UTILIZED BETWEEN EXISTING AND PROPOSED TO REDUCE VERTICAL CHANGE. SEE SHEET 11 FOR ADDITIONAL INFORMATION.

SAWCUTS WILL BE UTILIZED DURING DEMOLITION OF EXISTING SIDEWALKS. SIMILAR METHODS MAY BE USED UPON APPROVAL BY FIELD ENGINEER.

RAMPS SHALL NOT BE PLACED IN LINE WITH DRAINAGE STRUCTURES. LOCATION OF THE RAMP SHALL TAKE PRECEDENCE OVER LOCATION OF THE DRAINAGE STRUCTURE, EXCEPT WHERE EXISTING STRUCTURES ARE BEING UTILIZED FOR CONSTRUCTION OF NEW RAMPS.

ANY GRATE IN PEDESTRIAN AREAS SHALL HAVE OPENINGS NOT GREATER THAN 1/2" AND SHALL BE PLACED WITH LONG DIMENSION OF OPENING PERPENDICULAR TO THE DIRECTION OF PEDESTRIAN TRAVEL.

IF THE 8.33% (12:1) SLOPE CANNOT BE OBTAINED DUE TO GRADE OF THE ADJACENT ROADWAY, THE SLOPED PORTION OF THE RAMP SHALL BE EXTENDED TO A MINIMUM LENGTH OF 15'-0".

EXISTING CROSS WALK AND STOP BAR MARKINGS TO BE ERADICATED AND RELOCATED AS DICTATED BY PROPOSED RAMP LOCATIONS. COST NOT INCIDENTAL TO COST OF PROPOSED RAMP.

CURB RAMP WIDTH SHALL MATCH SIDEWALK WIDTH PLUS CLEARANCE. TYPICAL SIDEWALK WIDTH IS 5' MINIMUM. RAMP WIDTHS LESS THAN 5' REQUIRE DIVISION/DISTRICT ENGINEER APPROVAL. WIDTHS LESS THAN 4' REQUIRE AN EXCEPTION JUSTIFICATION REPORT. SEE SHEET 11 FOR INFORMATION REGARDING RAMP THICKNESS.

GRADE BREAKS SHALL BE PERPENDICULAR TO THE DIRECTION OF THE RAMP RUN. SURFACE SLOPES THAT MEET AT GRADE BREAKS SHALL BE FLUSH.

CLEAR SPACE- BEYOND THE BOTTOM GRADE BREAK, A CLEAR SPACE THE WIDTH OF THE CURB RAMP AND EXTENDING 4' MINIMUM INTO THE ABUTTING ROADWAY SHALL BE PROVIDED WITHIN THE WIDTH OF THE PEDESTRIAN STREET CROSSING AND WHOLLY OUTSIDE THE PARALLEL TRAVEL LANE. SURFACE TO MATCH EXISTING. ANY CLEAR SPACE WORK TO BE COMPLETED WILL BE INCIDENTAL TO THE COST OF THE RAMP.

ALL CURB RAMPS SHALL BE CONSTRUCTED TO PROVIDE ACCESS TO EXISTING OPERABLE PARTS. AN EXAMPLE OF THIS WOULD BE PEDESTRIAN PUSH BUTTONS.

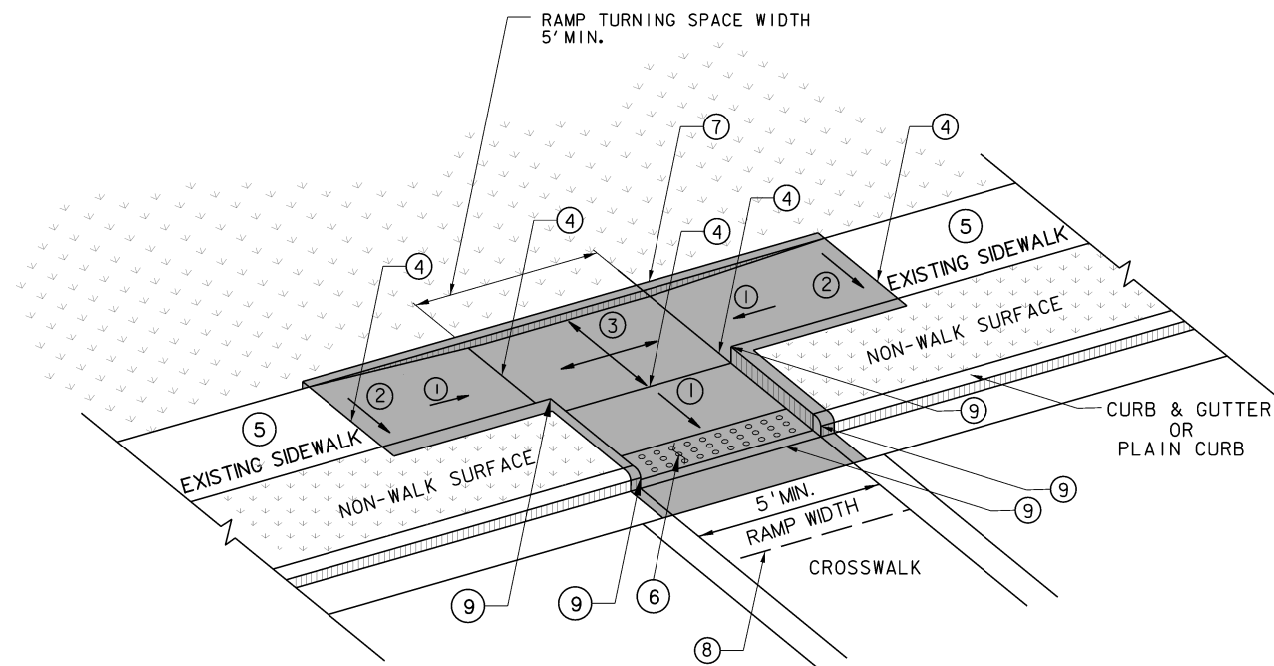

TYPE IV RAMP

LEGEND

- ① 8.33% (12:1) MAXIMUM RAMP SLOPE INCLUDING CONSTRUCTION TOLERANCE SLOPE OF RAMP SHALL CARRY THROUGH TO FACE OF CURB
- ② CROSS SLOPE: 2.00% MAXIMUM INCLUDING CONSTRUCTION TOLERANCE
- ③ CURB RAMPS REQUIRE A (5'-0") MINIMUM TURNING SPACE WHERE PEDESTRIANS PERFORM TURNING MANEUVERS WITH A MAXIMUM CROSS SLOPE OF 2% AND LONGITUDINAL SLOPE MATCHING ROADWAY
- ④ GRADE BREAK REQUIRED TO BE FLUSH (0") AND PERPENDICULAR TO PEDESTRIAN PATH OF TRAVEL
- ⑤ IF SIDEWALK IS EXISTING AND NON-COMPLIANT SEE "TRANSITION TO EXISTING NON-COMPLIANT SIDEWALK" DETAIL SHEET 12
- ⑥ DETECTABLE WARNING SURFACE SEE "DETECTABLE WARNING SURFACE (DWS)" DETAIL SHEET 11
- ⑦ CURB WALL OR CHEEK WALL AS DICTATED BY FIELD CONDITIONS. SEE "EXISTING ADJACENT SURFACE TRANSITION" DETAIL SHEET 13
- ⑧ CLEAR SPACE - WIDTH OF CURB RAMP AND EXTENDING 4' MINIMUM
- ⑨ 3/4" CHAMFER EDGE

 PAY LIMITS FOR CURB RAMPS (EXCLUDING DWS)

NOT TO SCALE

**WEST VIRGINIA DEPARTMENT OF TRANSPORTATION
DIVISION OF HIGHWAYS
STANDARD DETAIL**

PREPARED 1-1-1999

REVISION DATE
7/21/10
10/22/13
10/01/20

SIDEWALK RAMPS

(Sheet 9 of 13)

TYPE IV RAMP

STANDARD SHEET PVT 7

NOTES

THE TYPE OF RAMP TO BE USED SHALL BE AS SPECIFIED ON THE PLANS. THESE STANDARDS CAN BE CONSIDERED GUIDELINES IN SELECTING RAMP TYPES, HOWEVER THEY CAN BE DEVIATED FROM WITH A SPECIAL DETAIL AS NOTED IN PLANS.

RAMP CONCRETE SHALL MEET THE REQUIREMENTS OF SECTION 609 OF THE CURRENT WVDOT, DOH STANDARD SPECIFICATIONS ROADS AND BRIDGES AND ANY SUBSEQUENT DOH SUPPLEMENTAL SPECIFICATIONS, AND THE PUBLIC RIGHTS OF WAY ACCESSIBILITY GUIDELINES (PROWAG) DATED JULY 26, 2011. RAMP SURFACE SHALL INCLUDE A "DETECTABLE WARNING SURFACE" (SEE PVT7 SHT. 11 OF 13) AS SHOWN FOR EACH RAMP TYPE. A COARSE BROOM FINISH, TRANSVERSE TO FLARE SLOPES, OR EQUAL NON-SKID FINISH SHALL BE PROVIDED ON CONCRETE SURFACES.

NORMAL GUTTER FLOW LINE AND PROFILE SHALL BE MAINTAINED THROUGH THE RAMP AREA, UNLESS OTHERWISE SHOWN OR SPECIFIED. POSITIVE DRAINAGE MUST BE MAINTAINED SO THAT NO PONDING OCCURS WITHIN THE RAMP OR CLEAR SPACE AREA.

1/4" MINIMUM, 1/2" MAXIMUM PREFORMED EXPANSION JOINT FILLER, MEETING THE REQUIREMENTS OF SECTION 609 OF THE SPECIFICATIONS, AS NOTED ABOVE, SHALL BE PLACED AT ALL LOCATIONS WHERE RAMP CONTACTS CURB, GUTTER, CONCRETE PAVEMENT, OR OTHER RIGID OBJECTS.

WHERE EXISTING SIDEWALK CONNECTS TO PROPOSED SIDEWALK OR RAMPS, EXPANSION JOINTS ALONG WITH DOWEL BARS WILL BE PLACED. DOWEL BARS WILL BE UTILIZED BETWEEN EXISTING AND PROPOSED TO REDUCE VERTICAL CHANGE. SEE SHEET 11 FOR ADDITIONAL INFORMATION.

SAWCUTS WILL BE UTILIZED DURING DEMOLITION OF EXISTING SIDEWALKS. SIMILAR METHODS MAY BE USED UPON APPROVAL BY FIELD ENGINEER.

RAMPS SHALL NOT BE PLACED IN LINE WITH DRAINAGE STRUCTURES. LOCATION OF THE RAMP SHALL TAKE PRECEDENCE OVER LOCATION OF THE DRAINAGE STRUCTURE, EXCEPT WHERE EXISTING STRUCTURES ARE BEING UTILIZED FOR CONSTRUCTION OF NEW RAMPS.

ANY GRATE IN PEDESTRIAN AREAS SHALL HAVE OPENINGS NOT GREATER THAN 1/2" AND SHALL BE PLACED WITH LONG DIMENSION OF OPENING PERPENDICULAR TO THE DIRECTION OF PEDESTRIAN TRAVEL.

IF THE 8.33% (12:1) SLOPE CANNOT BE OBTAINED DUE TO GRADE OF THE ADJACENT ROADWAY, THE SLOPED PORTION OF THE RAMP SHALL BE EXTENDED TO A MINIMUM LENGTH OF 15'-0".

EXISTING CROSS WALK AND STOP BAR MARKINGS TO BE ERADICATED AND RELOCATED AS DICTATED BY PROPOSED RAMP LOCATIONS. COST NOT INCIDENTAL TO COST OF PROPOSED RAMP.

CURB RAMP WIDTH SHALL MATCH SIDEWALK WIDTH PLUS CLEARANCE. TYPICAL SIDEWALK WIDTH IS 5' MINIMUM. RAMP WIDTHS LESS THAN 5' REQUIRE DIVISION/DISTRICT ENGINEER APPROVAL. WIDTHS LESS THAN 4' REQUIRE AN EXCEPTION JUSTIFICATION REPORT. SEE SHEET 11 FOR INFORMATION REGARDING RAMP THICKNESS.

GRADE BREAKS SHALL BE PERPENDICULAR TO THE DIRECTION OF THE RAMP RUN. SURFACE SLOPES THAT MEET AT GRADE BREAKS SHALL BE FLUSH.

CLEAR SPACE- BEYOND THE BOTTOM GRADE BREAK, A CLEAR SPACE THE WIDTH OF THE CURB RAMP AND EXTENDING 4' MINIMUM INTO THE ABUTTING ROADWAY SHALL BE PROVIDED WITHIN THE WIDTH OF THE PEDESTRIAN STREET CROSSING AND WHOLLY OUTSIDE THE PARALLEL TRAVEL LANE. SURFACE TO MATCH EXISTING. ANY CLEAR SPACE WORK TO BE COMPLETED WILL BE INCIDENTAL TO THE COST OF THE RAMP.

ALL CURB RAMPS SHALL BE CONSTRUCTED TO PROVIDE ACCESS TO EXISTING OPERABLE PARTS. AN EXAMPLE OF THIS WOULD BE PEDESTRIAN PUSH BUTTONS.

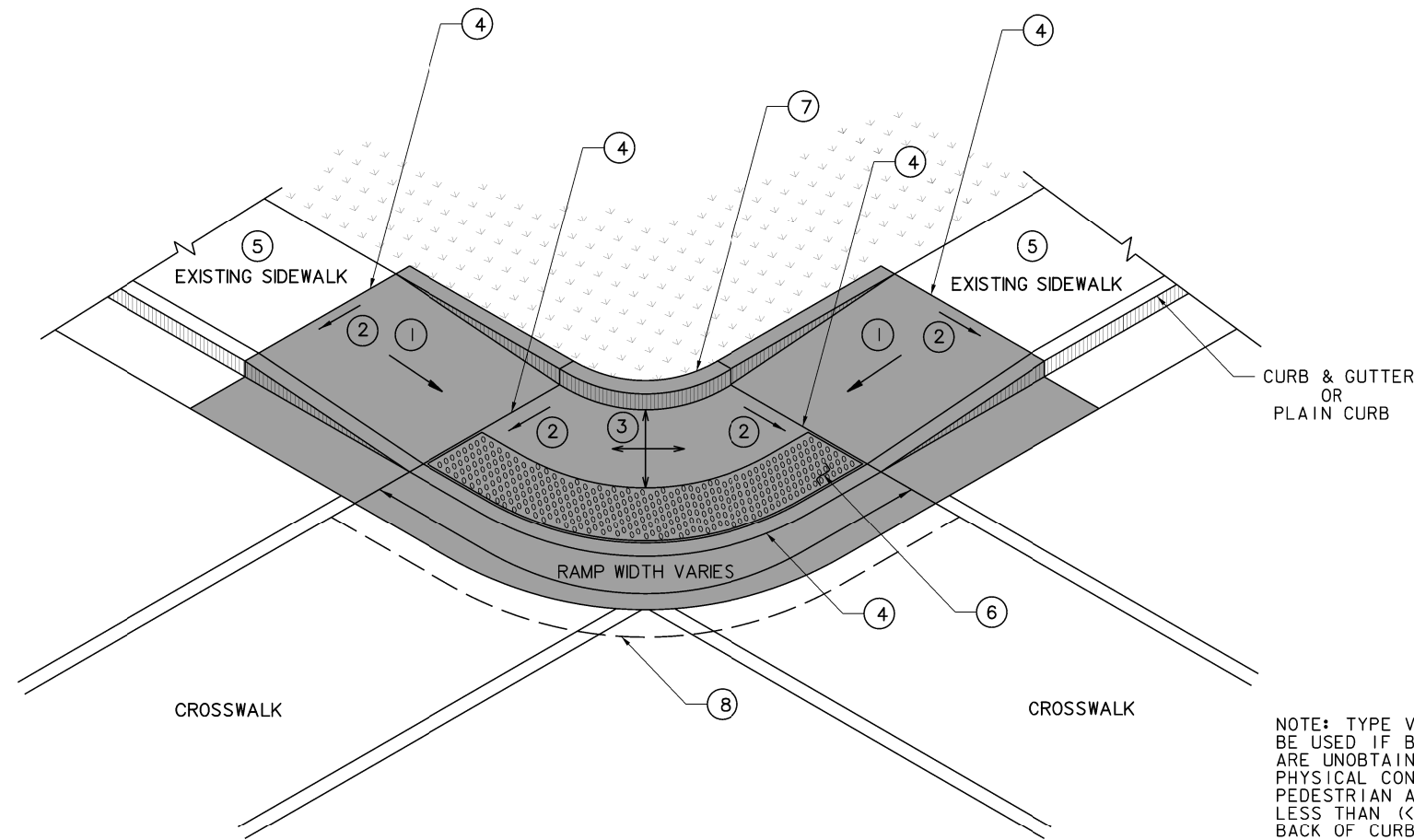

NOTE: TYPE V RAMPS ARE ONLY TO BE USED IF BIDIRECTIONAL RAMPS ARE UNOBTAINABLE DUE TO PHYSICAL CONSTRAINTS AND THE PEDESTRIAN ACCESS ROUTE (PAR) IS LESS THAN (<) 10' WIDE FROM BACK OF CURB TO BACK OF SIDEWALK.

TYPE V
DROP CORNER

LEGEND

- ① 8.33% (12:1) MAXIMUM RAMP SLOPE INCLUDING CONSTRUCTION TOLERANCE
SLOPE OF RAMP SHALL CARRY THROUGH TO FACE OF CURB
- ② CROSS SLOPE: 2.00% MAXIMUM INCLUDING CONSTRUCTION TOLERANCE
- ③ CURB RAMPS REQUIRE A (5'-0") MINIMUM TURNING SPACE WHERE PEDESTRIANS PERFORM TURNING MANEUVERS WITH A MAXIMUM CROSS SLOPE OF 2% AND LONGITUDINAL SLOPE MATCHING ROADWAY
- ④ GRADE BREAK REQUIRED TO BE FLUSH (0") AND PERPENDICULAR TO PEDESTRIAN PATH OF TRAVEL
- ⑤ IF SIDEWALK IS EXISTING AND NON-COMPLIANT SEE "TRANSITION TO EXISTING NON-COMPLIANT SIDEWALK" DETAIL SHEET 12
- ⑥ DETECTABLE WARNING SURFACE
SEE "DETECTABLE WARNING SURFACE (DWS)" DETAIL SHEET 11
- ⑦ CURB WALL OR CHEEK WALL AS DICTATED BY FIELD CONDITIONS. SEE "EXISTING ADJACENT SURFACE TRANSITION" DETAIL SHEET 13
- ⑧ CLEAR SPACE - WIDTH OF CURB RAMP AND EXTENDING 4' MINIMUM
- ⑨ 3/4" CHAMFER EDGE

PAY LIMITS FOR CURB RAMPS (EXCLUDING DWS)

NOT TO SCALE

WEST VIRGINIA DEPARTMENT OF TRANSPORTATION
DIVISION OF HIGHWAYS
STANDARD DETAIL

PREPARED 1-1-1999

REVISION DATE
7/21/10
10/22/13
10/01/20

SIDEWALK RAMPS
(Sheet 10 of 13)
TYPE V RAMP

STANDARD SHEET PVT 7

NOTES

DETECTABLE WARNING SURFACES (DWS'S) SHALL ONLY BE PURCHASED FROM VENDORS ON THE WEST VIRGINIA DIVISION OF HIGHWAYS APPROVED VENDOR LIST 609.2 - DETECTABLE WARNING SURFACES.

DESIGN AND PLACEMENT OF DETECTABLE WARNING SURFACE (DWS) SHALL BE IN ACCORDANCE WITH SECTION 609 OF THE CURRENT WVDOT, DOH STANDARD SPECIFICATIONS ROADS AND BRIDGES AND AND SUBSEQUENT DOH SUPPLEMENTAL SPECIFICATIONS AND THE PUBLIC RIGHTS OF WAY ACCESSIBILITY GUIDELINES (PROWAG) DATED JULY 26, 2011.

DETECTABLE WARNING SURFACES SHALL EXTEND ACROSS THE FULL WIDTH OF THE CURB RAMP THRESHOLD WHERE THE CURB IS FLUSH WITH THE ROADWAY AND SHALL BE PLACED AT THE BACK OF THE CURB WITH A 0" MINIMUM, 2" MAXIMUM BORDER DIMENSION FROM JOINTS ON EACH SIDE OF THE DWS. WHERE THE BACK OF THE CURB EDGE IS TOOLED TO PROVIDE A RADIUS, THE BORDER DIMENSION SHOULD BE MEASURED FROM THE END OF THE RADIUS.

DETECTABLE WARNING SURFACES SHALL CONTRAST VISUALLY WITH ADJACENT GUTTER, STREET, OR HIGHWAY. EITHER LIGHT ON DARK OR DARK ON LIGHT.

A WET OR PLASTIC SET-IN-PLACE DETECTABLE WARNING SURFACE (DWS) SHALL BE INSTALLED AT THE TIME OF THE PLACEMENT OF THE CURB RAMP, WHILE THE CONCRETE IS STILL PLASTIC.

MOLD-IN-PLACE CONCRETE DOMES, BRICK PAVERS, OR IRON OR STEEL WARNING SYSTEMS SHALL NOT BE USED.

SET-IN-PLACE DWS SHALL BE USED IN NEW CONSTRUCTION. SURFACE MOUNTED DWS ARE NOT PERMITTED.

CONCRETE SHALL BE EDGED AROUND THE DWS AT TIME OF PLACEMENT.

A SINGLE DWS PANEL SHALL BE USED WITH CURB RAMP WIDTHS OF 5' OR LESS.

ANY CUTTING OF DWS DURING INSTALLATION SHALL BE APPROVED BY PROJECT ENGINEER.

IF DWS IS CUT TO CONFORM TO A SPECIFIC SHAPE OF RAMP AND ANCHORING DEVICES BECOME PART OF THE WASTE, THEN ANCHOR WILL BE REMOVED AND REATTACHED INTO THE DWS AT THE ORIGINAL EDGE OFFSET AS PER MANUFACTURER.

ALL DOWEL BARS SHALL BE EPOXY COATED IN ACCORDANCE WITH SECTION 709.1 OF THE CURRENT WVDOH STANDARD SPECIFICATIONS ROADS AND BRIDGES

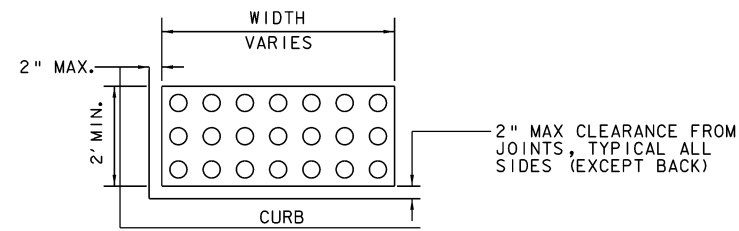

DETECTABLE WARNING SURFACE (DWS)

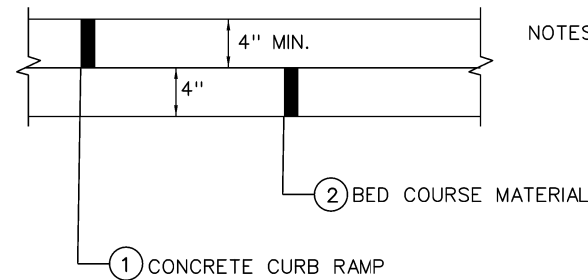

NOTES: CURB RAMP AND BED COURSE MATERIAL TO BE PAID BY ITEM 609005-001 CURB RAMP. THICKNESS OF CONCRETE SHALL BE INCREASED TO 6" MINIMUM IN AREAS EXPOSED TO TRAFFIC.

CURB RAMP TYPICAL

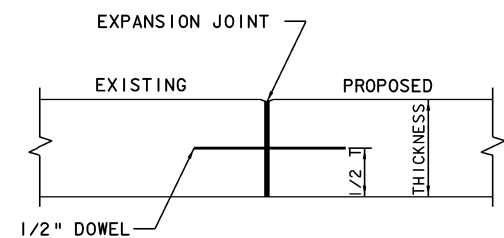

NOTE: 1/2" DOWEL TO BE EVENLY SPACED, MINIMUM LENGTH 8". COST OF DOWEL INSTALLATION INCIDENTAL TO COST OF RAMP.

CURB RAMP TYPICAL

NOT TO SCALE

WEST VIRGINIA DEPARTMENT OF TRANSPORTATION
DIVISION OF HIGHWAYS
STANDARD DETAIL

PREPARED 1-1-1999

REVISION DATE
7/21/10
10/22/13
10/01/20

SIDEWALK RAMPS
(Sheet 11 of 13)
DETECTABLE WARNING SURFACES & TYPICALS

STANDARD SHEET PVT 7

NOTES

TRANSITION CONCRETE SHALL MEET THE REQUIREMENTS OF SECTION 609 OF THE CURRENT WVDOT, DOH STANDARD SPECIFICATIONS ROADS AND BRIDGES AND ANY SUBSEQUENT DOH SUPPLEMENTAL SPECIFICATIONS, AND THE PUBLIC RIGHTS OF WAY ACCESSIBILITY GUIDELINES (PROWAG) DATED JULY 26, 2011. A COARSE BROOM FINISH, TRANSVERSE TO FLARE SLOPES, OR EQUAL NON-SKID FINISH SHALL BE PROVIDED ON CONCRETE SURFACES.

NORMAL GUTTER FLOW LINE AND PROFILE SHALL BE MAINTAINED THROUGH THE TRANSITION AREA, UNLESS OTHERWISE SHOWN OR SPECIFIED. POSITIVE DRAINAGE MUST BE MAINTAINED SO THAT NO PONDING OCCURS.

SURFACE SLOPES THAT MEET AT GRADE BREAKS SHALL BE FLUSH.

ANY GRATE IN PEDESTRIAN AREAS SHALL HAVE OPENINGS NOT GREATER THAN 1/2" AND SHALL BE PLACED WITH LONG DIMENSION OF OPENING PERPENDICULAR TO THE DIRECTION OF PEDESTRIAN TRAVEL.

ENSURE THAT THE TRANSITION AREA IS FULLY TAPERED FROM THE EXISTING NON-COMPLIANT SIDEWALK TO THE NEW SIDEWALK IN ORDER TO AVOID CREATING SUDDEN DROP OFFS ALONG THE PEDESTRIAN PATH OF TRAVEL.

WARP CONCRETE PLACED IN THE PROPOSED TRANSITION AREA TO MATCH THE EXISTING NON-COMPLIANT SIDEWALK CROSS SLOPE AND WIDTH.

THE LENGTH OF THE PROPOSED TRANSITION AREA IS BASED ON THE TRANSITION REQUIRED TO MEET CROSS SLOPE AND GRADE STANDARDS. SEE THE CHART ON THIS SHEET FOR CROSS SLOPE RANGES AND ASSOCIATED PROPOSED TRANSITION SIDEWALK AREA LENGTH. SHOULD EXISTING CROSS SLOPE EXCEED 9%, USE THE TREND SEEN IN THE CHART TO DETERMINE APPROPRIATE PROPOSED SIDEWALK TRANSITION AREA LENGTH.

SIDEWALK TRANSITION TO BE PAID AS 609001- \times CONCRETE SIDEWALK AND 609002- \times BED COURSE MATERIAL

TAPER LENGTHS TO BE DETERMINED BY SIDEWALK TRANSITION LENGTH. TAPER TO RUN CONSISTENTLY ALONG THE FULL LENGTH OF NEW TRANSITIONAL SIDEWALK AS SHOWN.

TRANSITION PIECE TO BE POURED BEYOND RAMP SLOPE WHEN TYING RAMP INTO NON-COMPLIANT EXISTING SIDEWALK.

ALL RAMP SLOPES TO BE BROUGHT TO FULL HEIGHT OF CURB BEFORE TRANSITION AREA STARTS.

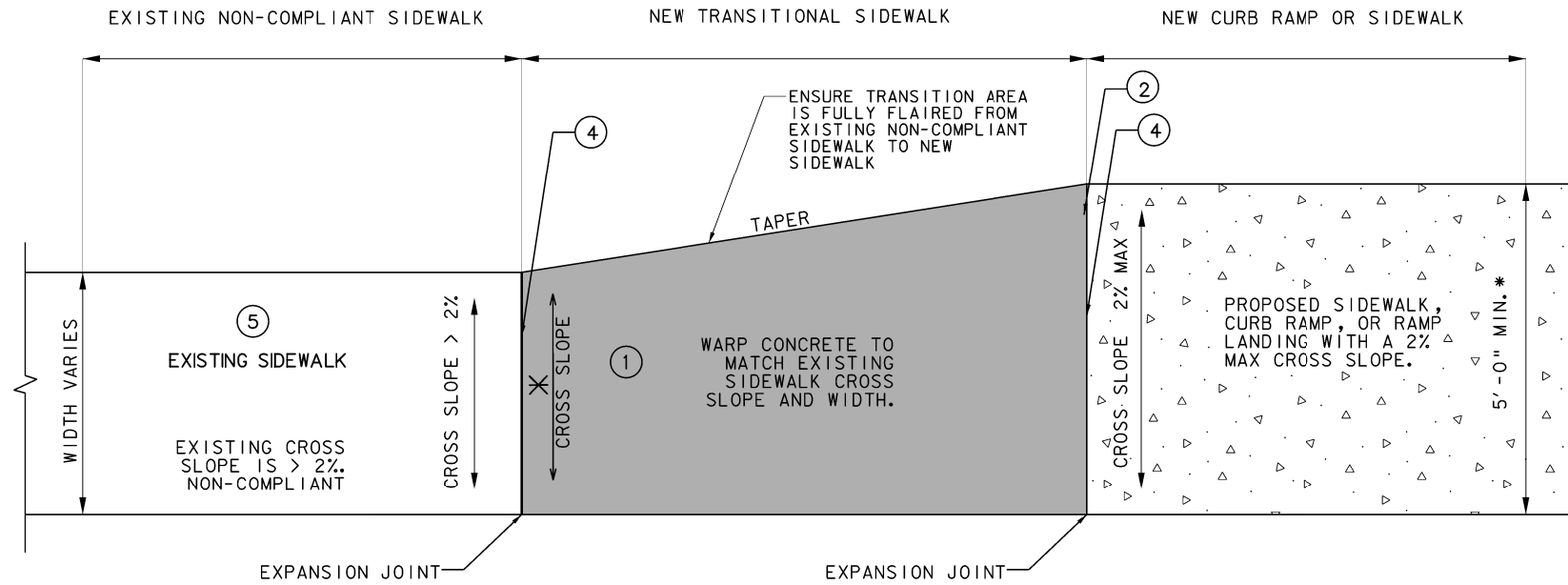

SIDEWALK TRANSITION FROM NON-COMPLIANT EXISTING TO PROPOSED

* SIDEWALK CROSS SLOPE TO BE ADJUSTED TO TRANSITION FROM EXISTING SIDEWALK TO PROPOSED RAMP

LEGEND

- ① 8.33%(12:1) MAXIMUM TRANSITION SIDEWALK SLOPE INCLUDING CONSTRUCTION TOLERANCE
- ② CROSS SLOPE: 2.00% MAX. INCLUDING CONSTRUCTION TOLERANCE
- ③ CURB RAMPS REQUIRE A (5'-0") MINIMUM TURNING SPACE WITH A MAXIMUM CROSS SLOPE OF 2% AND LONGITUDINAL SLOPE MATCHING ROADWAY WHERE PEDESTRIANS PERFORM TURNING MANEUVERS.
- ④ GRADE BREAK REQUIRED TO BE FLUSH (0") AND PERPENDICULAR TO PEDESTRIAN PATH OF TRAVEL
- ⑤ IF SIDEWALK IS EXISTING AND NON-COMPLIANT SEE "TRANSITION TO EXISTING NON-COMPLIANT SIDEWALK" DETAIL SHEET 11
- ⑥ DETECTABLE WARNING SURFACE SEE "DETECTABLE WARNING SURFACE (DWS)" DETAIL SHEET 10
- ⑦ CURB WALL OR CHEEK WALL AS DICTATED BY FIELD CONDITIONS. SEE "EXISTING ADJACENT SURFACE TRANSITION" DETAIL SHEET 13
- ⑧ CLEAR SPACE - WIDTH OF CURB RAMP AND EXTENDING 4' MINIMUM
- ⑨ 3/4" CHAMFER EDGE

CROSS SLOPE

EXISTING SIDEWALK CROSS SLOPE	SIDEWALK TRANSITIONAL LENGTH
0.00 - 2.00%	NOT REQUIRED
2.01 - 3.00%	1' 0"
3.01 - 4.00%	2' 0"
4.01 - 5.00%	3' 0"
5.01 - 6.00%	4' 0"
6.01 - 7.00%	5' 0"
7.01 - 8.00%	6' 0"
8.01 - 9.00%	7' 0"

 PAY LIMITS FOR SIDEWALK TRANSITION

NOT TO SCALE

WEST VIRGINIA DEPARTMENT OF TRANSPORTATION
DIVISION OF HIGHWAYS
STANDARD DETAIL

PREPARED 1-1-1999

REVISION DATE
7/21/10
10/22/13
10/01/20

SIDEWALK RAMPS
 (Sheet 12 of 13)
SIDEWALK TRANSITION AREA

STANDARD SHEET PVT 7

NOTES

DETAILS ON THIS SHEET USED TO SHOW OPTIONAL METHODS TO TRANSITION FROM EXISTING ROLLABLE AND NON-ROLLABLE SURFACES TO ADJACENT PROPOSED CURB RAMPS AND SIDEWALKS ONLY. ROLLABLE SURFACES INCLUDE, BUT ARE NOT LIMITED TO COMMERCIAL AREAS ADJACENT TO PROPOSED RAMPS.

CHEEK WALLS AND CURB WALLS SHALL MEET THE REQUIREMENTS OF SECTION 610 OF THE CURRENT WVDOT, DOH STANDARD SPECIFICATIONS ROADS AND BRIDGES AND ANY SUBSEQUENT DOH SUPPLEMENTAL SPECIFICATIONS.

1/4" MINIMUM, 1/2" MAXIMUM PREFORMED EXPANSION JOINT FILLER, MEETING THE REQUIREMENTS OF SECTION 609 OF THE SPECIFICATIONS, AS NOTED ABOVE, SHALL BE PLACED AT ALL LOCATIONS WHERE RAMP CONTACTS CURB, GUTTER, CONCRETE PAVEMENT, OR OTHER RIGID OBJECTS.

WHERE PROPOSED CURB RAMP CONNECTS TO PROPOSED CURB/ CHEEK WALL, EXPANSION JOINTS ALONG WITH DOWEL BARS WILL BE PLACED. DOWEL BARS WILL BE UTILIZED BETWEEN EXISTING AND PROPOSED TO REDUCE VERTICAL CHANGE. SEE SHEET 11 FOR ADDITIONAL INFORMATION.

SAWCUTS WILL BE UTILIZED DURING DEMOLITION OF EXISTING SIDEWALKS. SIMILAR METHODS MAY BE USED UPON APPROVAL BY FIELD ENGINEER.

AS A MINIMUM, TOP AND BACK OF VISIBLE CURB WALL ABUTTING ADJUSTING ROLLABLE SURFACE SHALL BE PAINTED WITH HIGH DEFINITION YELLOW PAINT.

CHEEK AND CURB WALLS MAY NOT BE REQUIRED WHEN WALL OR BUILDING PRESENT.

AS PREVIOUSLY NOTED, THE COST OF CHEEK WALL OR CURB WALL IS INCIDENTAL TO COST OF CURB RAMP.

1/2" DOWEL TO BE EVENLY SPACED. MINIMUM LENGTH TO BE 8". COST OF DOWEL INSTALLATION TO BE INCIDENTAL TO COST OF RAMP.

SEE STANDARD SHEET PVT3 FOR DETAIL OF TIE BAR AND CHANNEL TO BE USED FOR FORMING LONGITUDINAL JOINT.

ALL DOWEL BARS SHALL BE EPOXY COATED IN ACCORDANCE WITH SECTION 709.1 OF THE CURRENT WVDOT STANDARD SPECIFICATIONS ROADS AND BRIDGES.

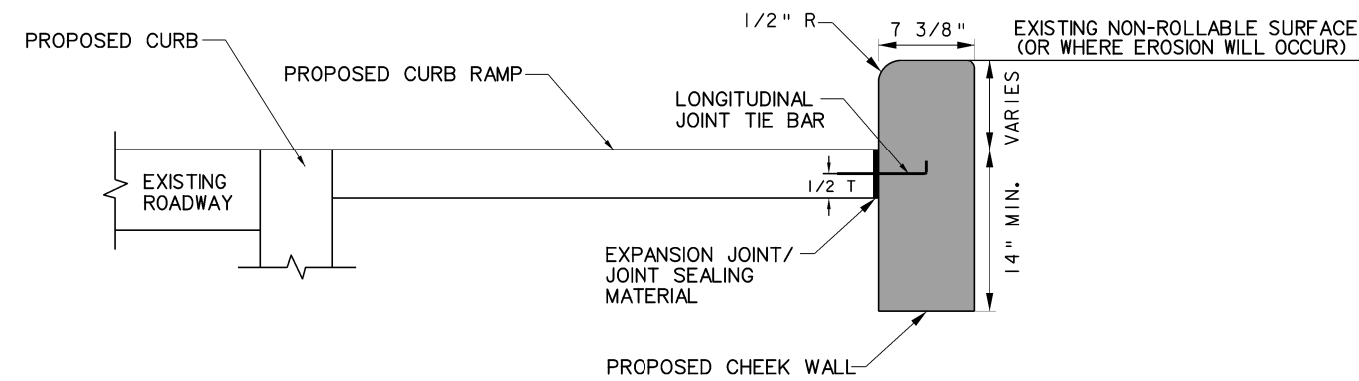

① CHEEK WALL

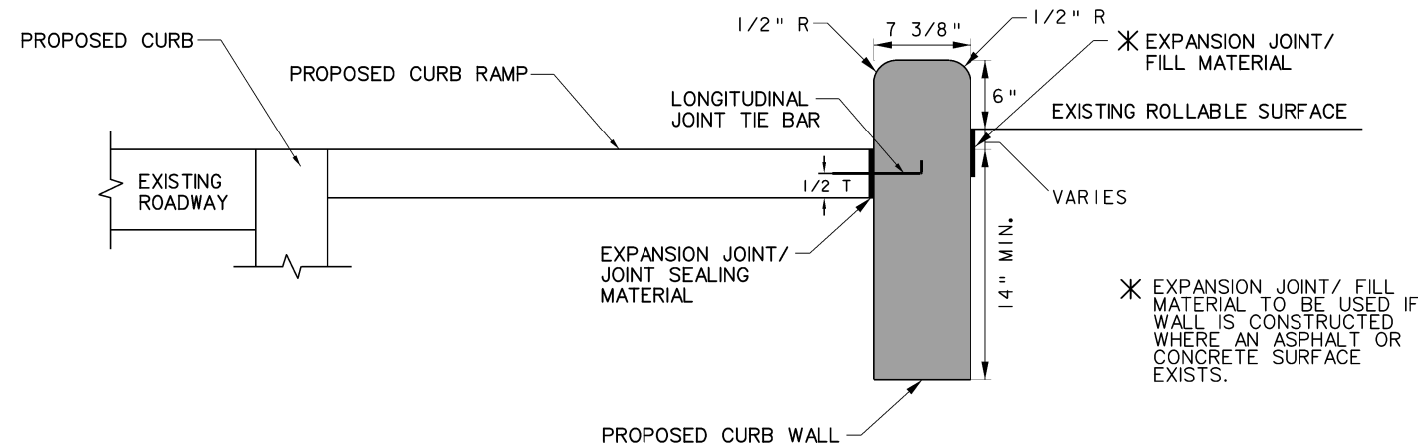

② CURB WALL

EXISTING ADJACENT SURFACE TRANSITION DETAIL

PAY LIMITS FOR PROPOSED ADJACENT SURFACE TRANSITION DETAIL (INCIDENTAL TO 609005-CURB RAMP)

NOT TO SCALE

WEST VIRGINIA DEPARTMENT OF TRANSPORTATION DIVISION OF HIGHWAYS STANDARD DETAIL	
PREPARED 1-1-1999	<p>SIDEWALK RAMPS (Sheet 13 of 13) EXISTING ADJACENT SURFACE TRANSITION DETAIL STANDARD SHEET PVT 7</p>
REVISION DATE	
7/21/10	
10/22/13	
10/01/20	

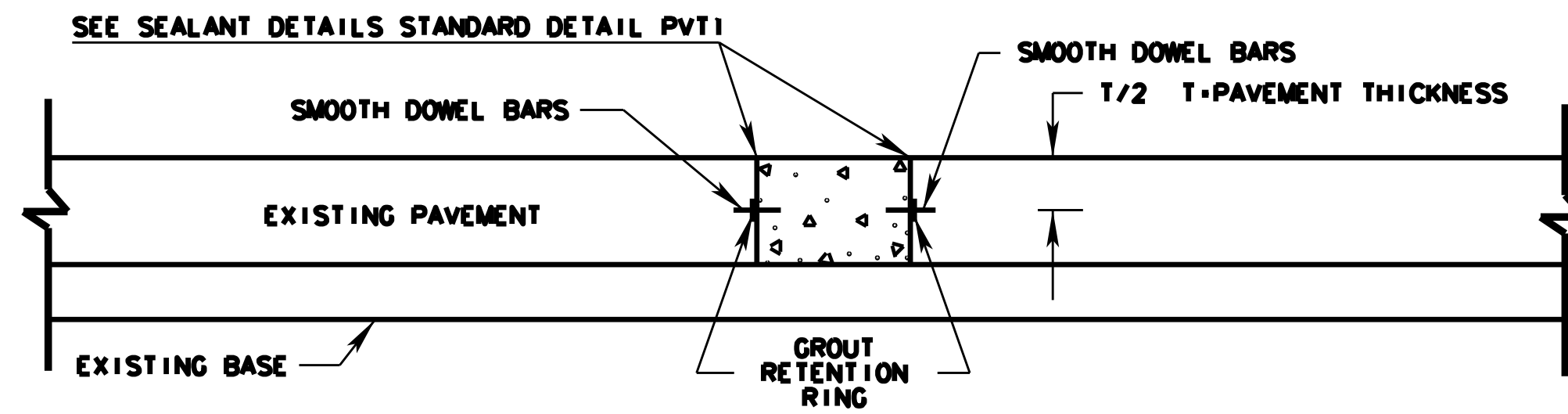
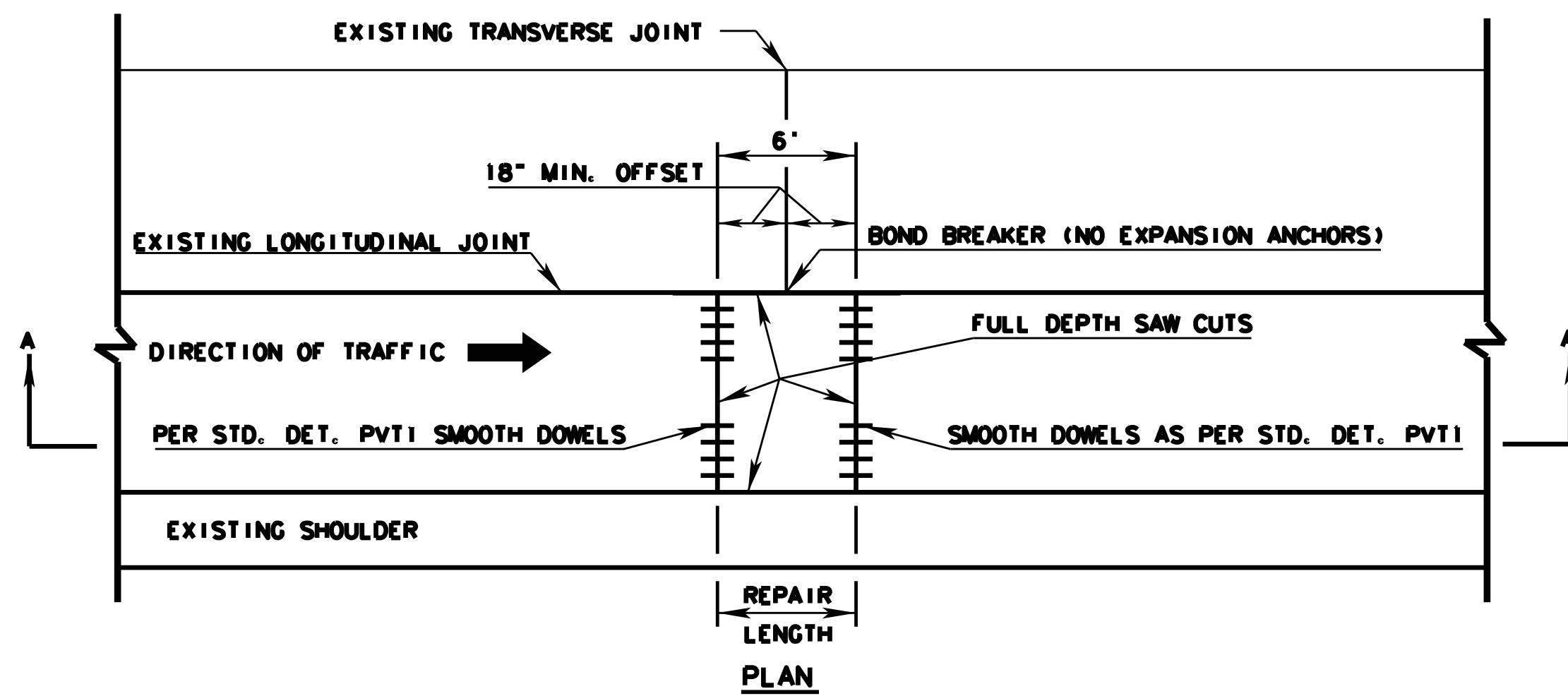

REPAIRS PERFORMED AT AN EXISTING TRANSVERSE JOINT EVEN THOUGH ONLY ONE SIDE NEEDS REPAIR. THE TOTAL REPAIR LENGTH SHALL BE 6 FOOT.

CONCRETE REPAIR DETAIL METHOD A 6'

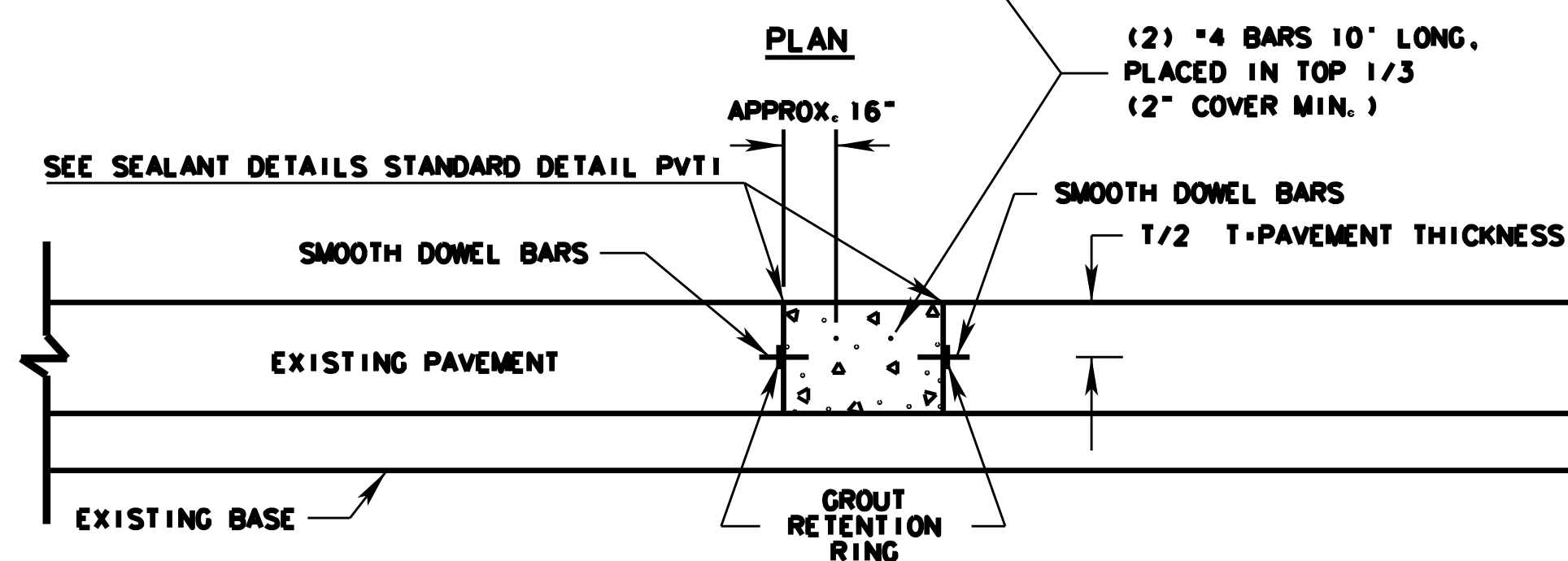
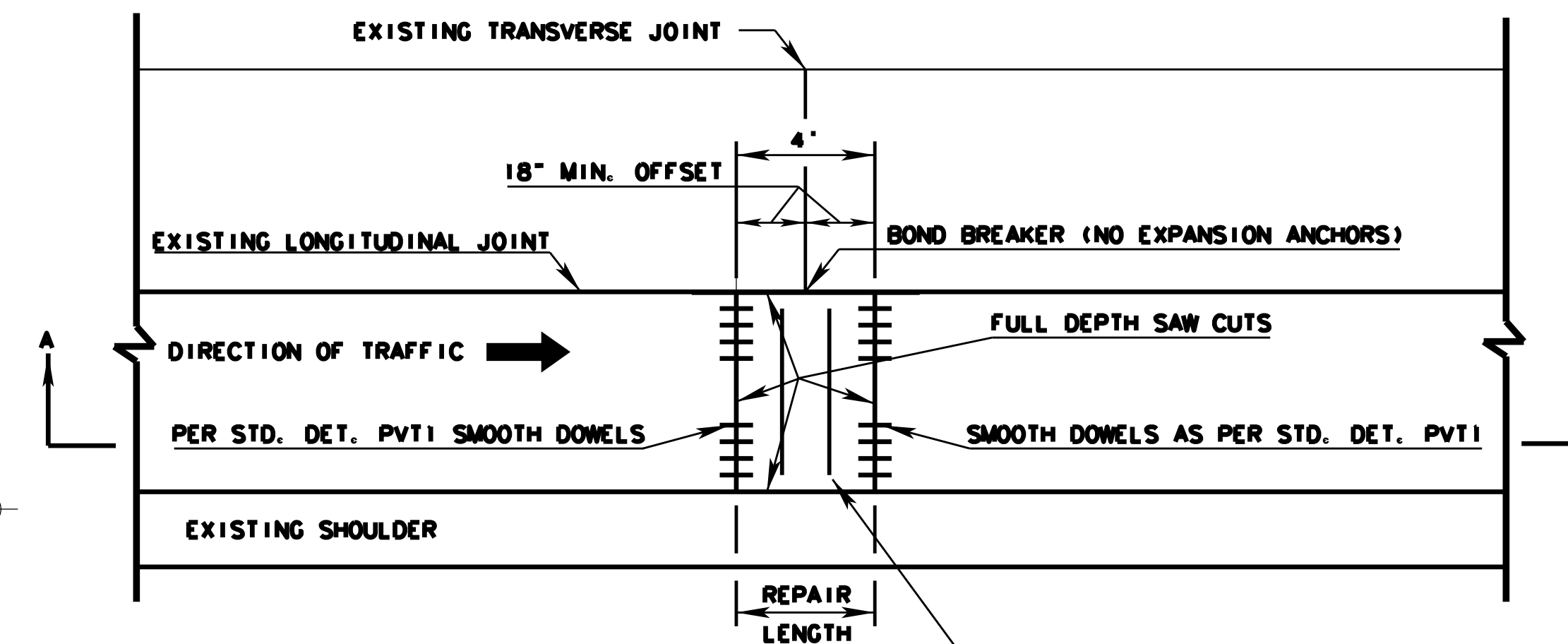

REPAIRS PERFORMED AT AN EXISTING TRANSVERSE JOINT EVEN THOUGH ONLY ONE SIDE NEEDS REPAIR. THE TOTAL REPAIR LENGTH SHALL BE 4 FOOT.

CONCRETE REPAIR DETAIL METHOD A 4'

GENERAL NOTES

REPAIRS SHALL BE MADE USING CONCRETE MEETING THE REQUIREMENTS OF SECTION 501 OF THE SPECIFICATIONS, SUBGRADE PREPARATION SHALL BE IN ACCORDANCE WITH SUBSECTION 228 OF THE SPECIFICATIONS AND MAY REQUIRE ADDITIONAL MATERIAL TO FACILITATE PLACEMENT OF LOAD TRANSFER UNITS. COST TO BE INCLUDED IN VARIOUS ITEMS IN THE CONTRACT.

HOLES FOR THE DOWELS AND LOAD TRANSFER UNITS SHALL BE DRILLED SIMULTANEOUSLY TO THE REQUIRED DEPTH USING FRAME MOUNTED DRILLS WHICH WILL MAINTAIN THE DRILLS IN A LONGITUDINALLY PARALLEL POSITION. HOLE DIAMETER SHALL BE 1/4" LARGER FOR CEMENT GROUTS AND 1/16" FOR EPOXIES THAN THE BAR DIAMETER. AN EPOXY BONDING COMPOUND AS APPROVED BY THE WVDOT MATERIALS CONTROL, SOIL AND TESTING DIVISION SHALL BE USED TO SECURE THE DOWEL/TIE BARS IN PLACE.

JOINTS SHALL BE MADE IN ACCORDANCE WITH SECTION 501 OF THE SPECIFICATIONS AND DETAILS ATTACHED IN PLANS. ALL DOWELS SHALL BE EPOXY COATED.

OVERSAWING INTO ADJACENT SLABS WHEN ONLY ONE LANE OR PORTION OF A LANE IS TO BE REMOVED SHALL BE KEPT TO THE MINIMUM NECESSARY TO ENSURE THAT FULL DEPTH CUTS IN THE CORNERS HAVE BEEN ACHIEVED. ALL OVERSAWING SHALL BE THOROUGHLY CLEANED AND REPAIRED WITH AN EPOXY BONDING COMPOUND AS APPROVED BY THE WVDOT MATERIALS CONTROL, SOILS AND TESTING DIVISION.

PAYMENT SHALL BE FULL COMPENSATION FOR ALL LABOR, EQUIPMENT, MATERIALS AND INCIDENTALS REQUIRED FOR REMOVING AND REPLACING EXISTING PORTLAND CEMENT CONCRETE PAVEMENT IN ACCORDANCE WITH THE ABOVE DETAILS. COST SHALL BE INCLUDED IN THE UNIT BID PRICE FOR ITEM 506001-001 CONCRETE PAVEMENT REPAIR.

THE CONTRACTOR IS REQUIRED TO SCHEDULE WORK ON ALL CONCRETE PAVEMENT REPAIRS IN SUCH A MANNER THAT WILL NOT PERMIT OPEN HOLES TO REMAIN OPEN OVERNIGHT OR ON WEEKENDS.

MINIMUM 1/4" DIAMETER PLAIN EPOXY COATED DOWEL BARS, AS PER STANDARD DETAIL SHEET PVT4, WILL BE USED AT BOTH ENDS OF THE REPAIR. STARTING 6-12 INCHES FROM EITHER EDGE AND THEN ON 12" CENTERS.

TYPE D OR MODIFIED TYPE E JOINTS AS PER STANDARD DETAIL SHEETS PVT4 AND PVT2 MAY BE USED FOR THE LONGITUDINAL CONSTRUCTION JOINT. BARS SHALL BE SPACED ON 30" CENTERS WITH THE EXCEPTION THAT BARS WILL NOT BE PLACED WITHIN 36" OF A WORKING CONSTRUCTION JOINT OR AN ADJACENT TRANSVERSE CONTRACTION JOINT, OR AN ADJACENT WORKING CRACK THAT WILL NOT BE REPAIRED. A BOND BREAKER WILL BE PLACED IN THIS AREA IN LIEU OF THE EXPANSION ANCHORS.

FOR PAVEMENT REPAIR LENGTHS GREATER THAN 15', LOAD TRANSFER UNITS AS PER STANDARD DETAIL SHEET PVT4 SHALL BE INSTALLED:

1. TO MATCH ADJACENT CONTRACTION JOINTS OR RANDOM TRANSVERSE CRACKS IF ONLY ONE LANE IS REPLACED, OR
2. ON 15' CENTERS IF MORE THAN ONE LANE OF PAVEMENT REPAIR IS BEING REPLACED.

CONTRACTION JOINTS IN THE ADJACENT LANE SCHEDULED TO REMAIN SHALL BE SEALED ON THEIR LOGITUDINAL FACE PRIOR TO PLACEMENT OF CONCRETE IN THE REPAIR AREA IN ORDER TO PREVENT NEW CONCRETE FROM ENTERING.

HOT POUR JOINT SEALANT MEETING ASTM SPECIFICATION D3405 MAY BE SUBSTITUTED FOR THE LOW-MODULUS SILICONE SEALANT SPECIFIED ON STANDARD DETAIL SHEET PVT1.

WEST VIRGINIA DEPARTMENT OF TRANSPORTATION
DIVISION OF HIGHWAYS
STANDARD DETAIL

STANDARD DETAIL

PREPARED 4-7-17

REVISION DATE

CONCRETE REPAIR DETAILS

(SHEET 1 OF 2)

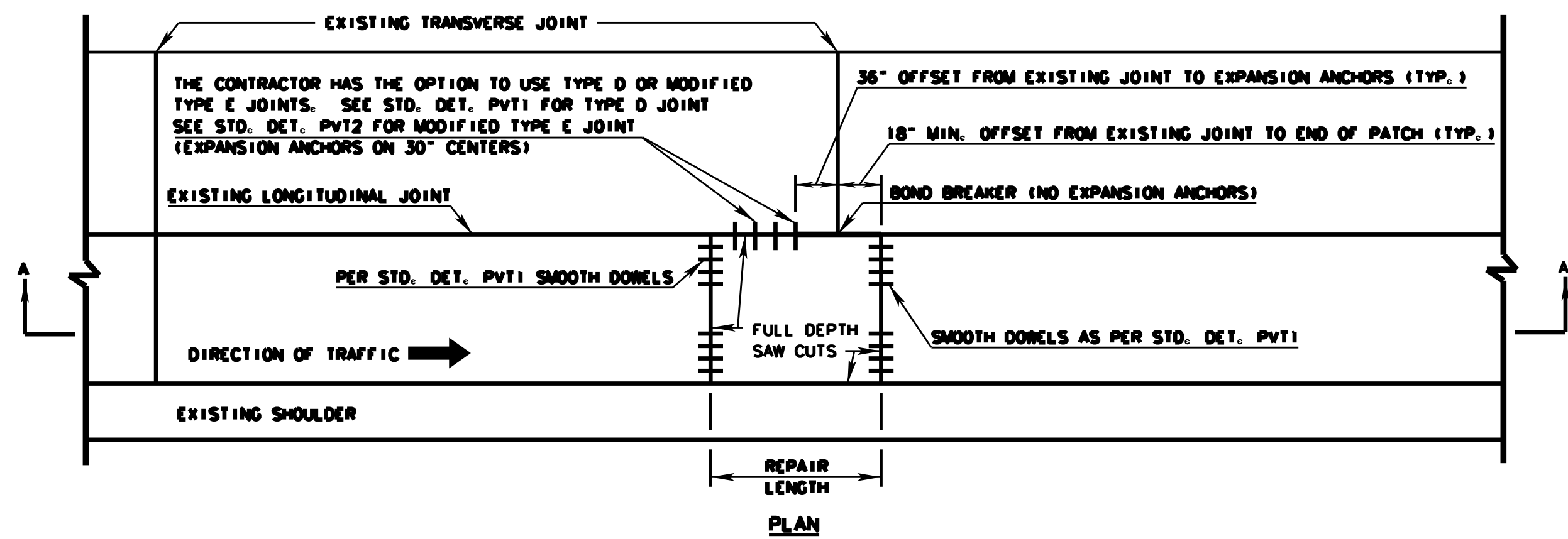

PLAN

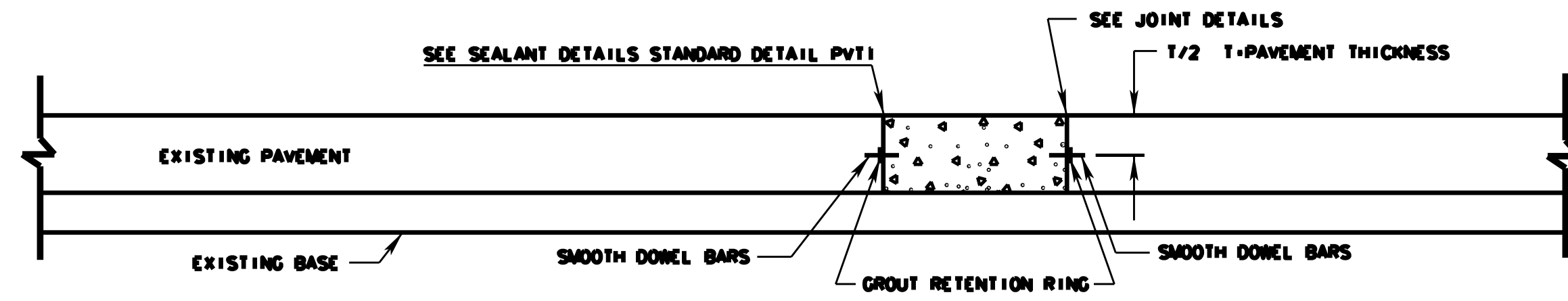

SECTION A-A

CONCRETE REPAIR DETAIL METHOD B

REPAIRS PERFORMED AT AN EXISTING TRANSVERSE JOINT WHEN THE REPAIR EXCEEDS 36" ON ONLY ONE SIDE OF THE JOINT. (NOTE THAT THE 18" OFFSET IS TO ALLOW FOR THE REMOVAL AND REPLACEMENT OF DOWELS.) REPAIRS ARE GREATER THAN 6" BUT LESS THAN 15" IN LENGTH AND REQUIRE LONGITUDINAL TYPE D OR MODIFIED TYPE E JOINTS.

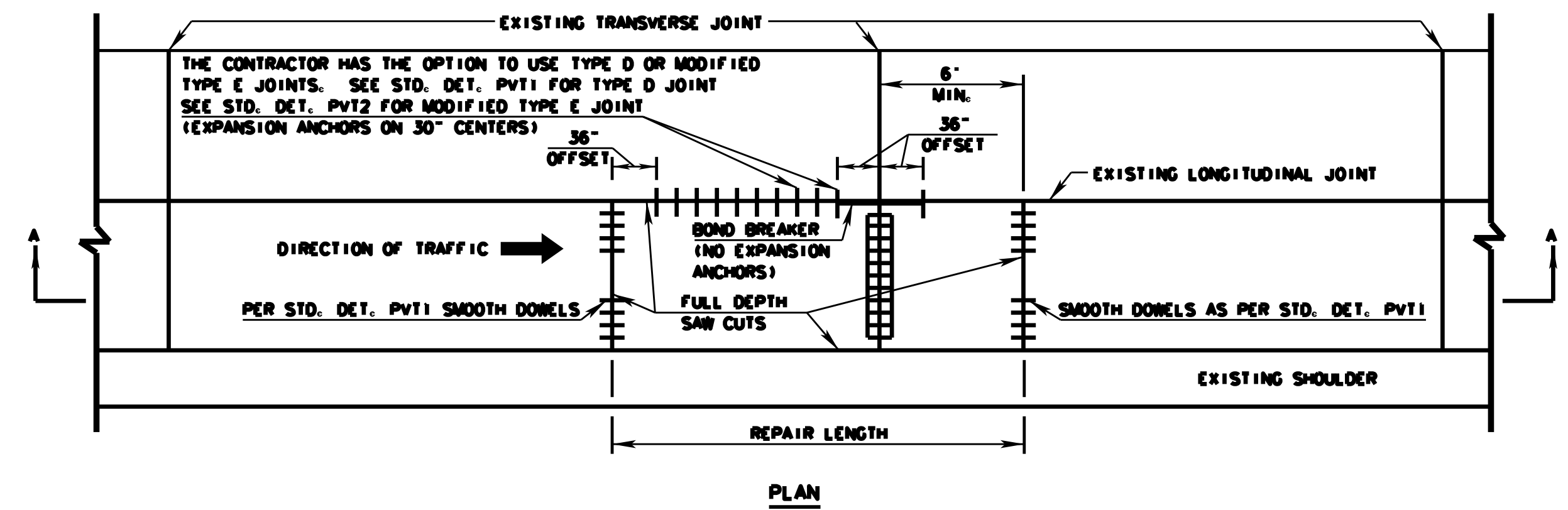

PLAN

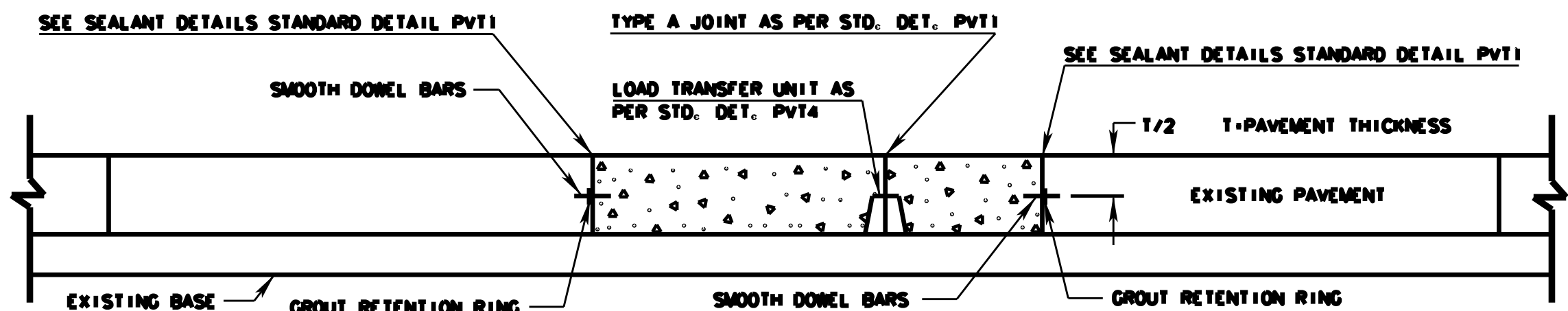

SECTION A-A

CONCRETE REPAIR DETAIL METHOD C

REPAIRS EXCEEDING 36" ON BOTH SIDES OF AN EXISTING TRANSVERSE JOINT. REPAIR SLABS AND REMAINS OF EXISTING SLABS SHALL NOT BE LESS THAN 15" IN LENGTH.

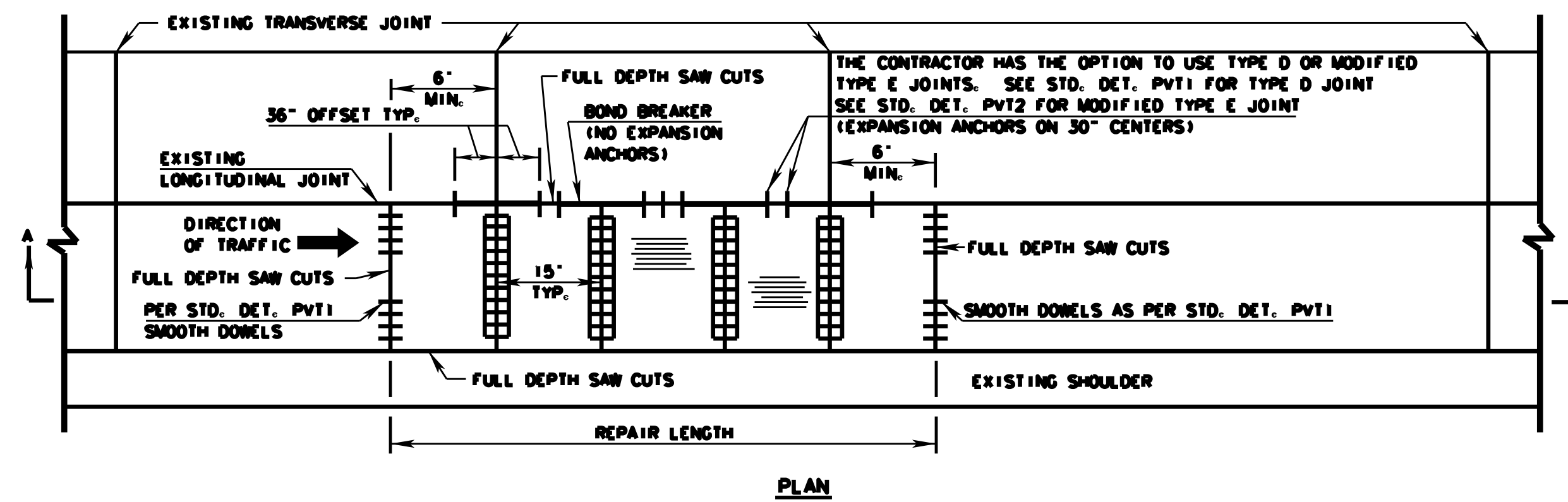

PLAN

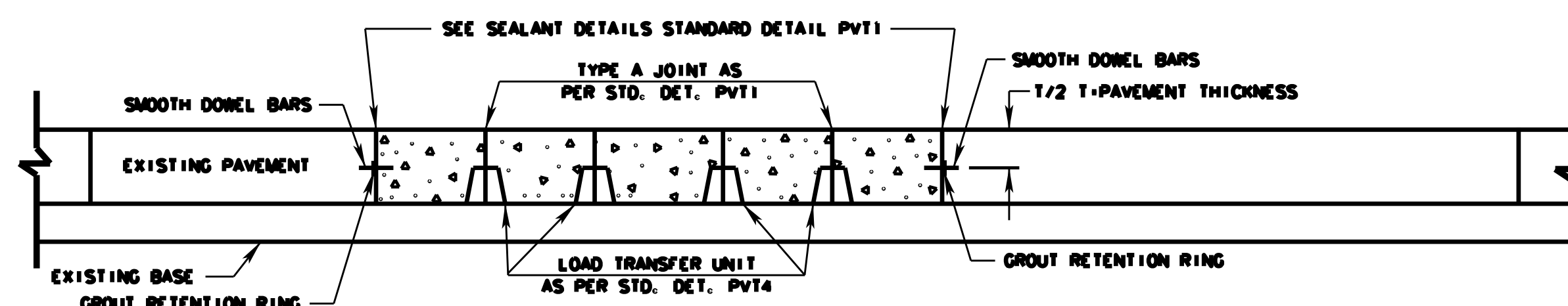

SECTION A-A

CONCRETE REPAIR DETAIL METHOD D

REPAIRS PERFORMED TO COMPLETELY REPLACE SLABS BETWEEN TWO JOINTS. EXISTING DOWELS AND ASSEMBLIES SHALL BE COMPLETELY REMOVED WHEN A REPAIR IS PERFORMED AT A TRANSVERSE JOINT.

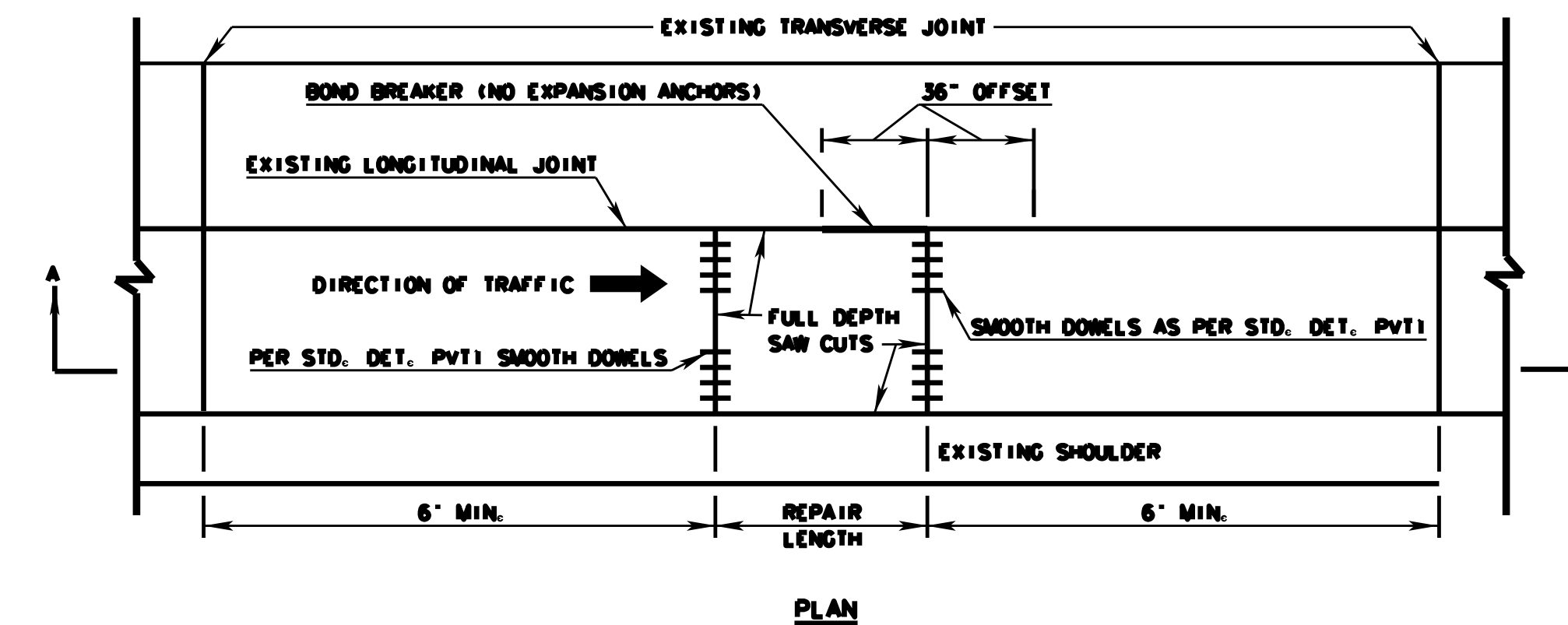

PLAN

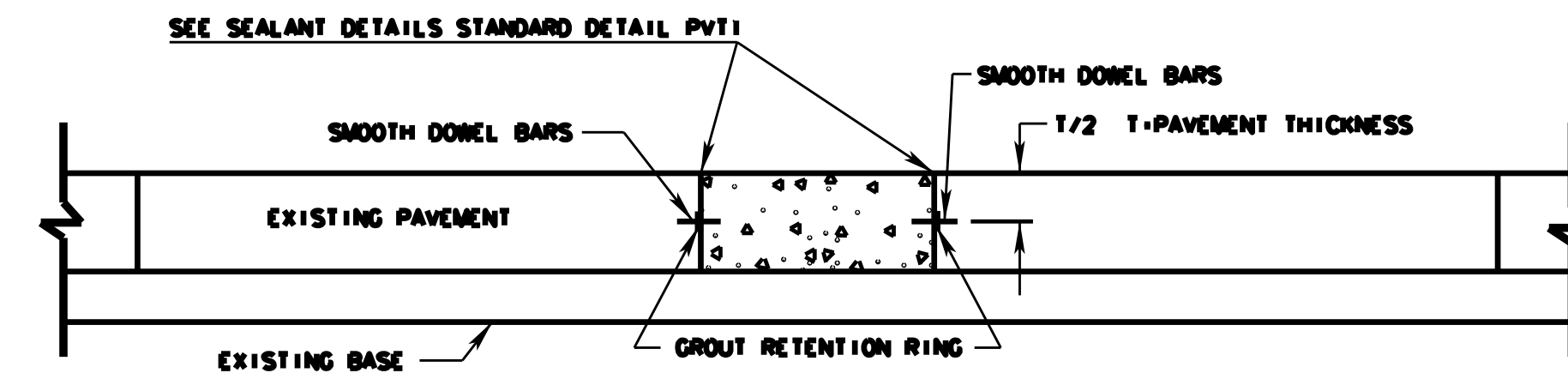

SECTION A-A

CONCRETE REPAIR DETAIL METHOD E

REPAIRS PERFORMED AT MID SLAB SHALL BE A MINIMUM OF 6" FROM AN EXISTING TRANSVERSE JOINT. DETAIL METHODS A, B, C AND D SHALL APPLY.

WEST VIRGINIA DEPARTMENT OF TRANSPORTATION
DIVISION OF HIGHWAYS
STANDARD DETAIL

STANDARD DETAIL

PREPARED 4-7-17
REVISION DATE

CONCRETE REPAIR DETAILS

(SHEET 2 OF 2)

• For Type and Size, see Fence members table on sheet 2 of 2.

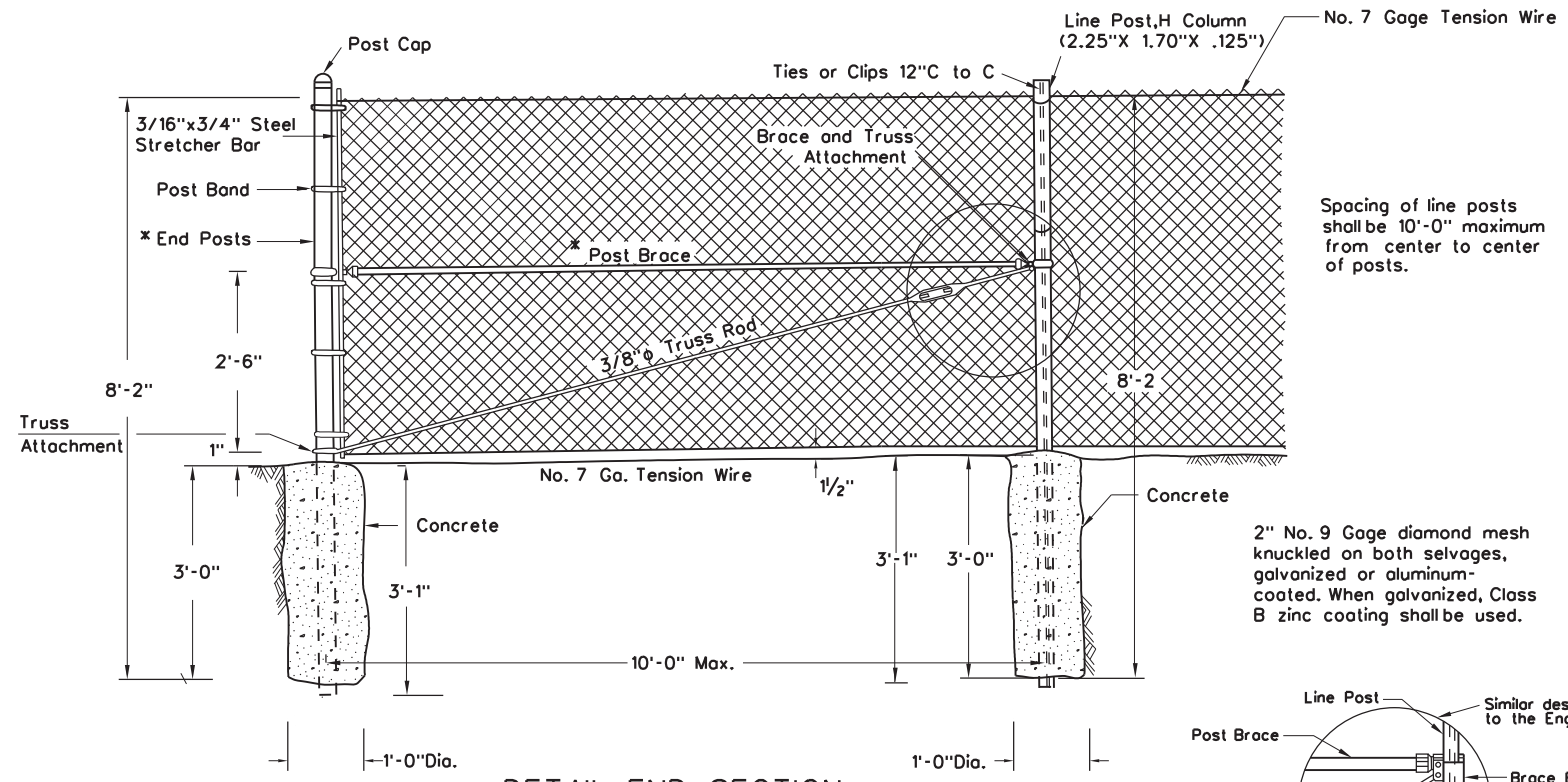

DETAIL-END SECTION

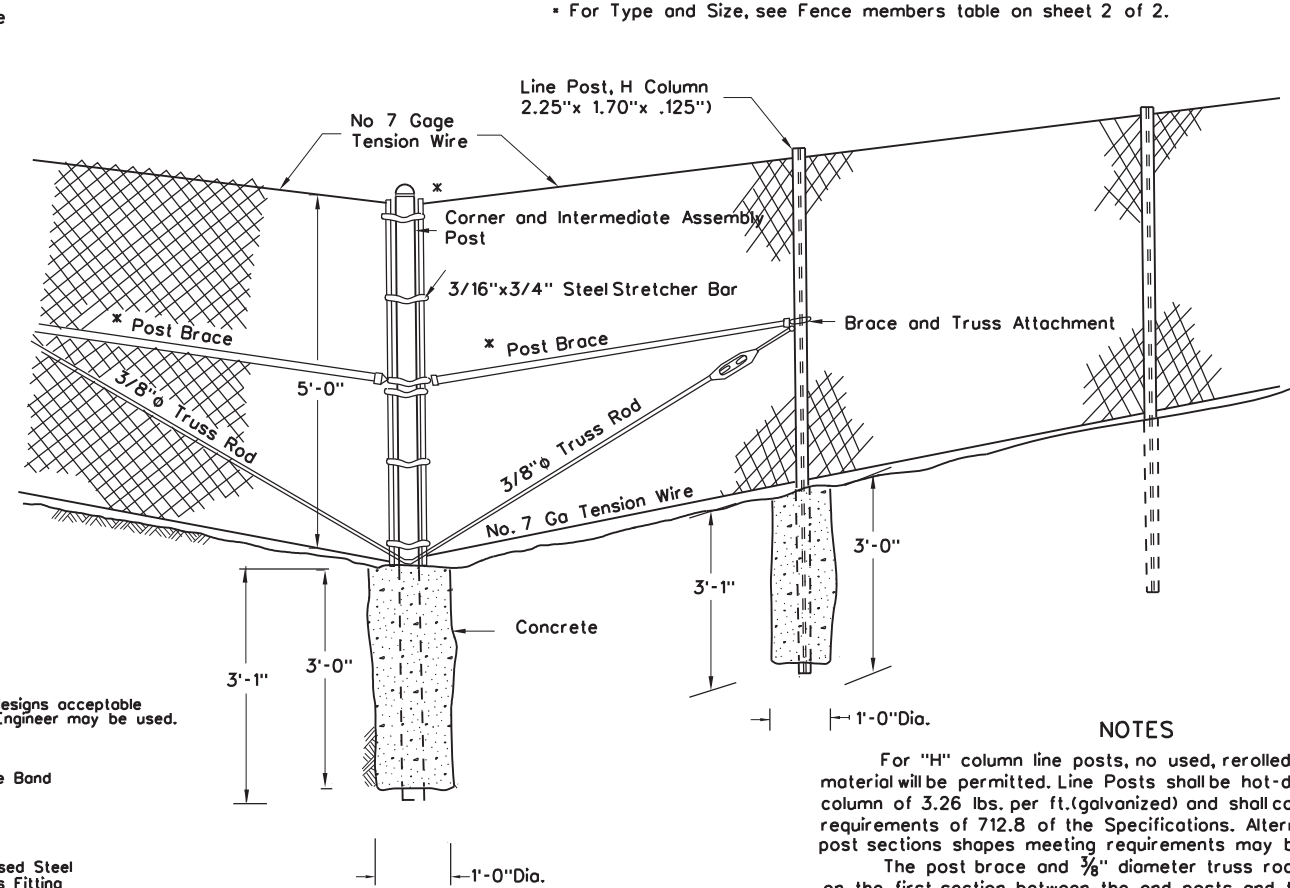

DETAIL-CORNER AND INTERMEDIATE ASSEMBLY SECTIONS

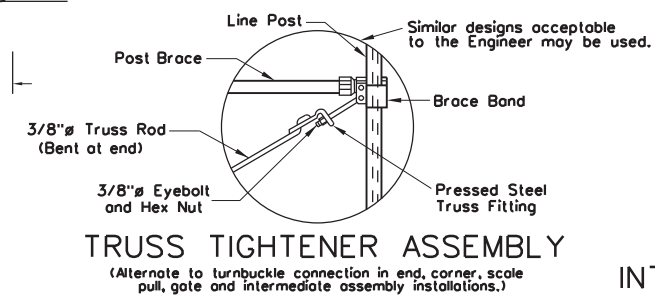

TRUSS TIGHTENER ASSEMBLY
(Alternate to turnbuckle connection in end, corner, scale pull, gate and intermediate assembly installations.)

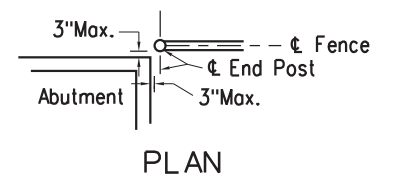

PLAN

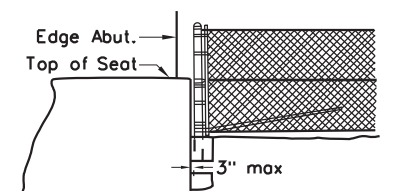

ELEVATION
DETAIL OF R/W FENCE AT ABUTMENTS

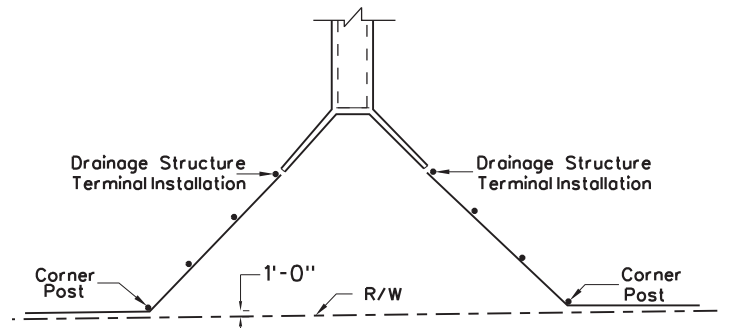

TYPICAL FENCE ALIGNMENT AT WINGWALLS FOR PIPES OR BOX CULVERTS

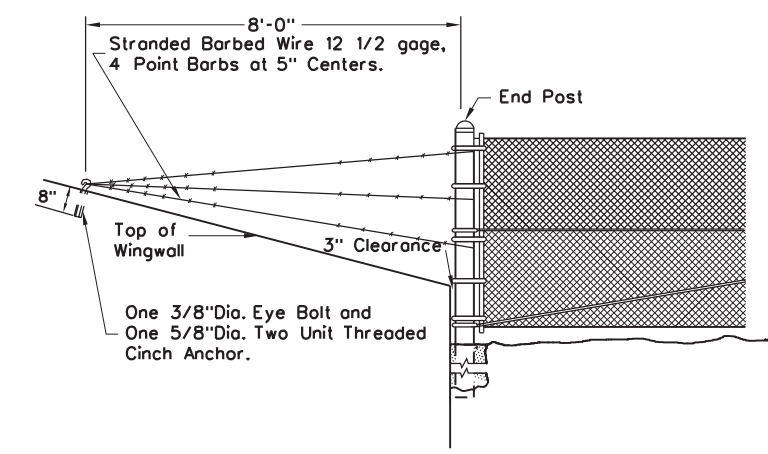

DRAINAGE STRUCTURE TERMINAL INSTALLATION

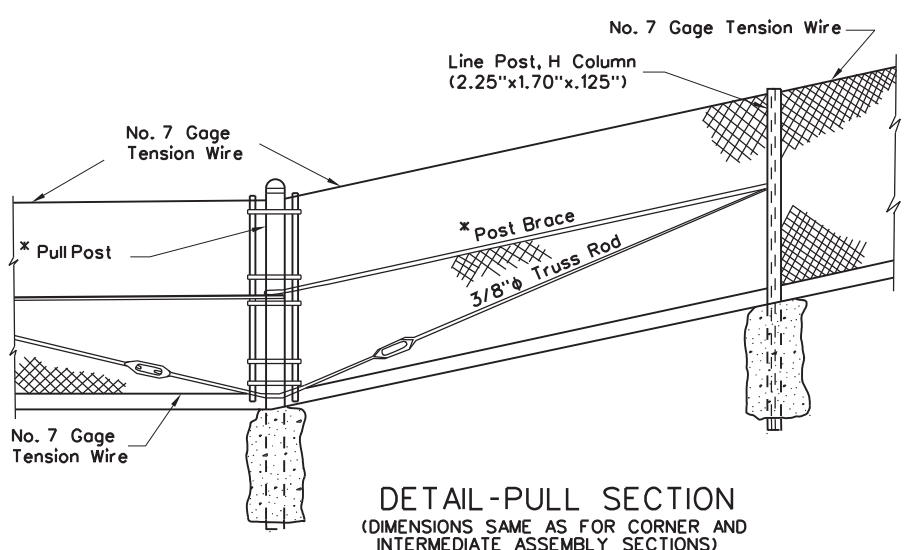

DETAIL-PULL SECTION
(DIMENSIONS SAME AS FOR CORNER AND INTERMEDIATE ASSEMBLY SECTIONS)

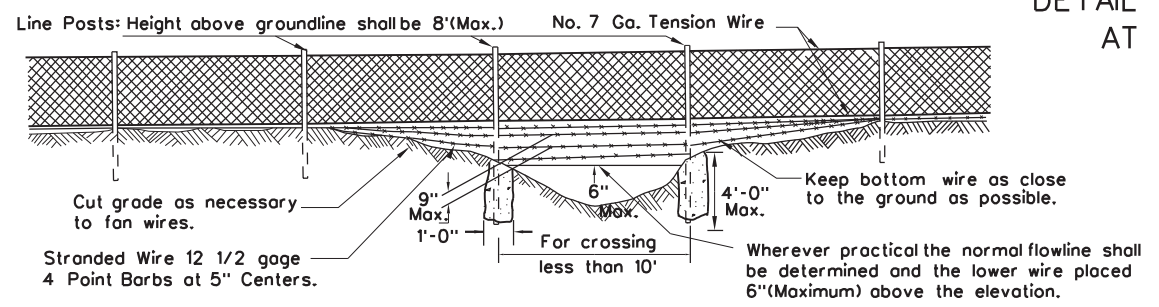

DETAIL SHOWING TYPICAL SECTION AT MINOR DEPRESSIONS AND WET WEATHER CROSSINGS

NOTES

For "H" column line posts, no used, rerolled or open seam material will be permitted. Line Posts shall be hot-dip galvanized "H" column of 3.26 lbs. per ft. (galvanized) and shall conform to the requirements of 712.8 of the Specifications. Alternate roll formed line post sections meeting requirements may be used with approval.

The post brace and 3/8" diameter truss rod must be used on the first section between the end posts and the first line post, and on the first section both sides between the corner, intermediate assembly or pull post and the first line post. Line posts adjacent to end, pull, corner, gate and intermediate assembly posts shall be set in concrete. Other line posts shall not be set in concrete; except length line posts: 9'-6" and longer, shall be pipe posts set in concrete footings.

Chain link fence fabric may be either zinc-coated or aluminum-coated unless one type is specifically called for. However, only one type shall be used throughout any one project.

Dumped rock channel protection to be used at channel crossings when called for on plans.

Install Drainage Structure Installations as called for on the plans and as detailed herein.

Post caps for end, corner, gate, line or pull posts shall be swage fitted or securely attached to pipe posts by means of set screws, pins or rivets.

Unless otherwise specified, or directed by the Engineer, chain link fence may be installed with the fence fabric positioned on either side line posts.

Hardware and miscellaneous fittings, not specifically designated herein as to type or dimensions, shall conform to the applicable requirements of 608 of the Specifications and shall be good-quality commercial design acceptable to the Engineer.

In lieu of the barbed wire detail herein, the following additional types are acceptable, provided they retain the "4-point barb at 5-inch centers" requirement and provided they meet or exceed the strength and coating requirements for the stranded, 12 1/2 gage, barbed wire as called for in 712.10 of the Specifications:

(a) stranded, 15 1/2 gage, high carbon steel barbed wire.
(b) one-strand, 12 gage, steel barbed wire.

WEST VIRGINIA DEPARTMENT OF TRANSPORTATION
DIVISION OF HIGHWAYS
STANDARD DETAIL

PREPARED	7-1-99
REVISION DATE	
	8-19-10

R/W FENCE-CHAIN LINK
5' FENCE FABRIC HEIGHT
(sheet 1 of 2)
STANDARD SHEET F1

* For Types and Sizes, see Fence Members Table herein.

Similar designs meeting the approval of the Engineer may be used.

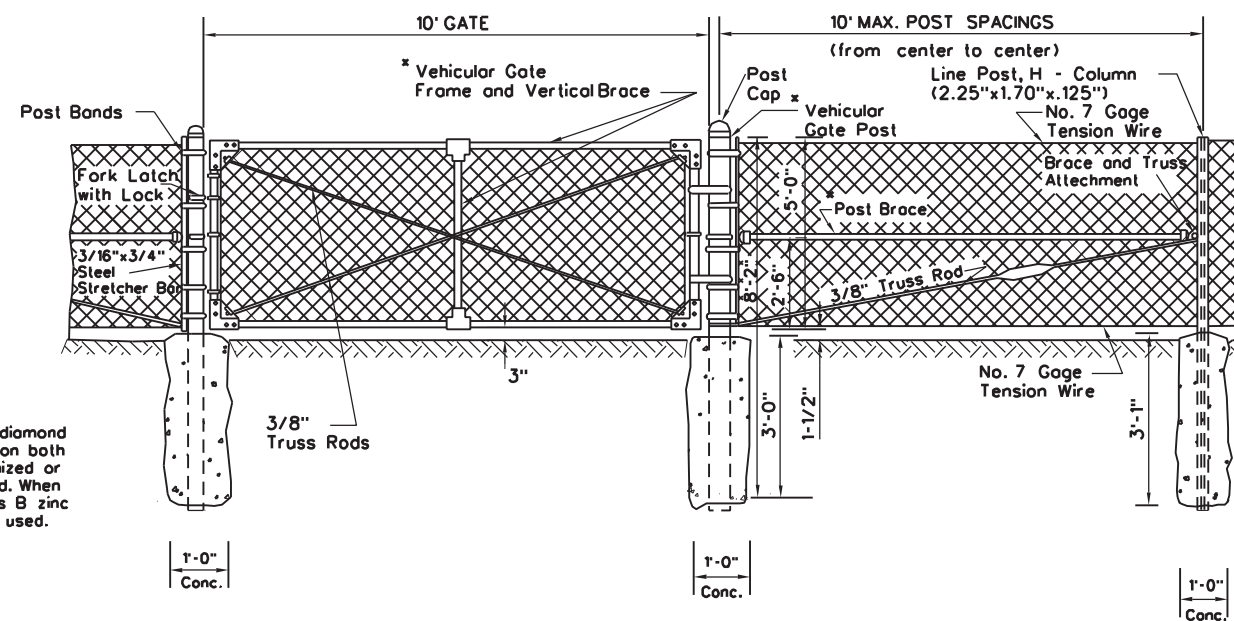
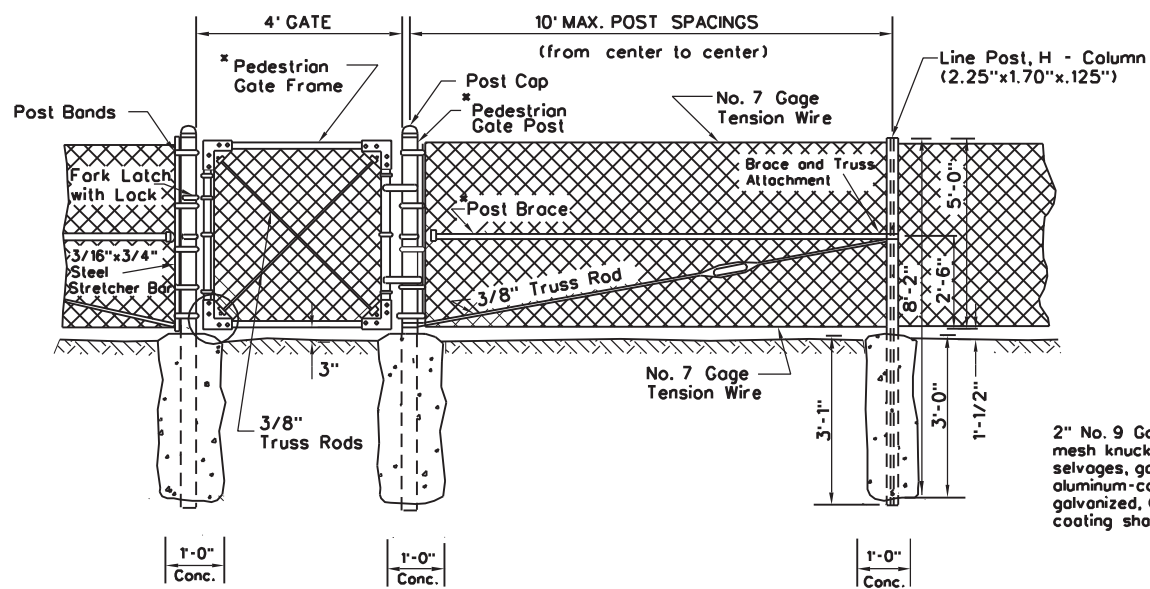
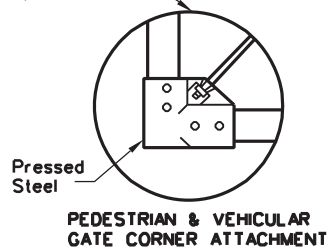

2" No. 9 Gage diamond mesh knuckled on both selvages, galvanized or aluminum-coated. When galvanized, Class B zinc coating shall be used.

PEDESTRIAN GATE DETAIL

VEHICULAR GATE DETAIL

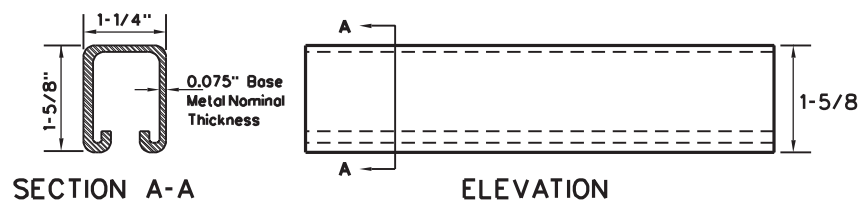
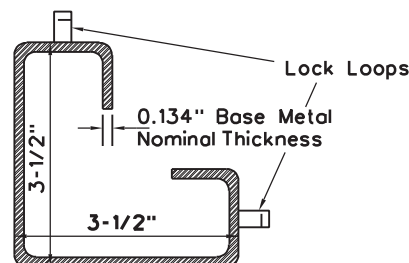

BRACE DETAIL

(Galvanized Weight = 1.35 Lbs./Ft.)

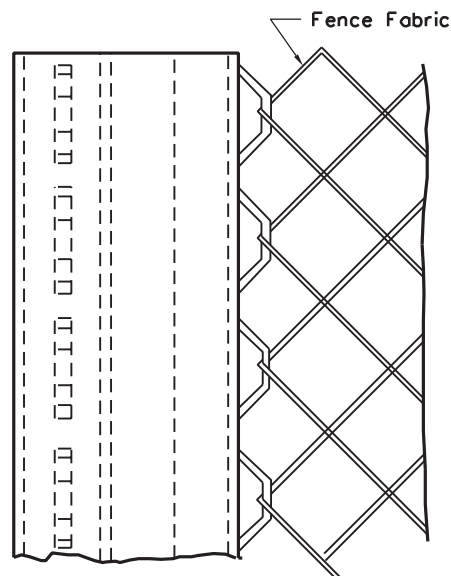

Note:
Fabric to be woven into the lock loops for the entire height of fence.

POST DETAIL

(Galvanized Weight = 5.14 Lbs./Ft.)

ROLL FORMED MEMBERS

NOTES

- The applicable details and notes of Standard Sheet F1 (Sheet 1 of 2) shall apply to this Standard Sheet.
- Except for "normal length" line posts, all other posts and braces shall be galvanized steel pipe members or galvanized steel roll formed members as shown in the "Fence Members Table" herein. When galvanized pipe posts are used, galvanized post braces shall be used.
- When roll formed posts are used, roll formed post braces shall be employed.
- Roll formed posts and braces shall meet the requirements of 712.8 of the Specifications.
- Stretcher bars, and their accompanying post bands, shall not be used with the roll formed posts. Instead, the fence fabric shall be integrally woven into the lock loops of the posts.
- Post caps shall not be used on roll formed posts.
- Gate frames and gate vertical braces shall be galvanized pipe members. Gate fabric shall have the same coating as the fence fabric. All other metal components of gates shall be galvanized, with the exception of die-cast aluminum corner fittings, or pressed steel corner fittings.

Member Designation	Galvanized Pipe			Triple Coated Pipe			Galv. Roll Formed Members		
	I.D. In.	Wall Thk. In.	Wt. lbs./ft.	I.D. In.	Wall Thk. In. (min.)	Wt. lbs./ft. (min.)	Dimensions In.	Wall Thk. In.	Wt. lbs./ft.
End, Pull, Corner and Intermediate Assembly Post	2	0.154	3.65	2	0.130	3.11	3.5 x 3.5	0.134	5.14
Post Brace	1.25	0.140	2.27	1.25	0.11	1.83	1.250 x 1.625	0.075	1.35
Pedestrian Gate Post	2.5	0.203	5.79	2.5	0.160	4.64	3.5 x 3.5	0.134	5.14
Pedestrian Gate Frame	1.25	0.140	2.27	1.25	0.11	1.83	-	-	-
Vehicular Gate Post	3.5	0.226	9.11	-	-	-	-	-	-
Vehicular Gate Frame (and Vertical Brace)	1.5	0.145	2.72	1.5	0.120	2.28	-	-	-
Special Length Line Post (for 9'-6" and over)	2	0.154	3.65	2	0.130	3.11	3.5 x 3.5	0.134	5.14

WEST VIRGINIA DEPARTMENT OF TRANSPORTATION
DIVISION OF HIGHWAYS
STANDARD DETAIL

PREPARED 7-1-99
REVISION DATE

RW FENCE-CHAIN LINK
5' FENCE FABRIC HEIGHT
(sheet 2 of 2)

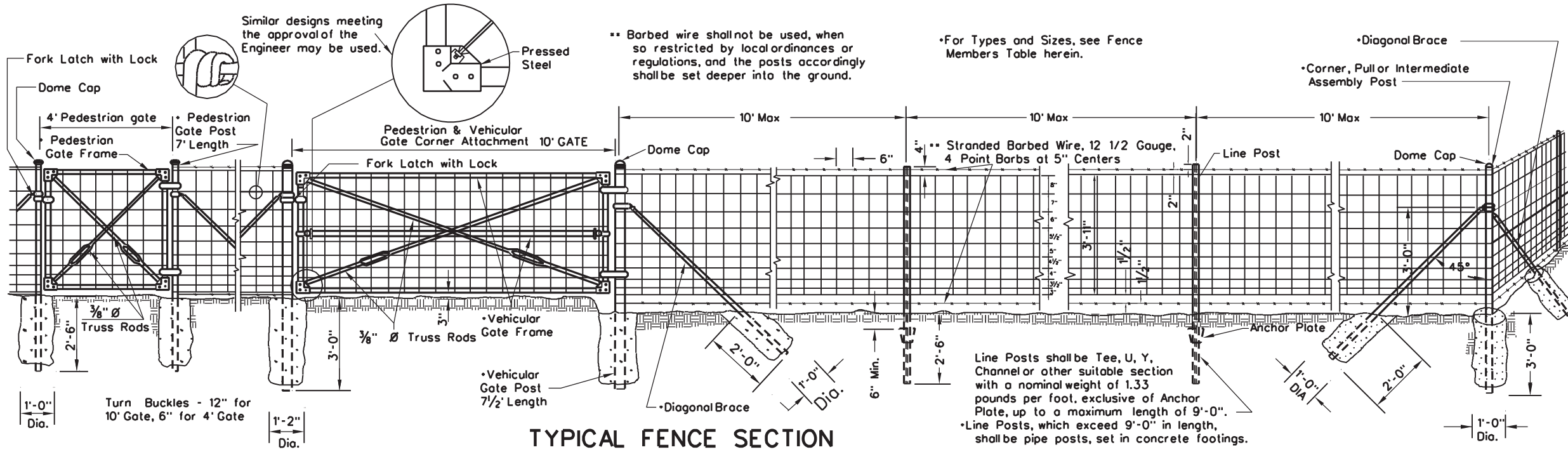

TYPICAL FENCE SECTION

NOTES

Except for "normal length" line posts, all other posts and their diagonal braces shall be either galvanized steel pipe members or triple-coated steel pipe members as shown in the "Fence Members Table" herein. When galvanized pipe posts are used, galvanized pipe diagonal braces shall be used. When triple-coated pipe posts are used, triple-coated pipe diagonal braces shall be employed.

Gate frames may be either galvanized pipe members or triple-coated pipe members. All other metal components of gates shall be galvanized, with the exception of die-cast aluminum corner fittings, pressed steel corner fittings.

Unless otherwise specified, or directed by the Engineer, the farm field fence may be installed with the fence fabric and barbed wire positioned on either side of the fence posts.

In lieu of the barbed wire detailed herein, the following additional types are acceptable, provided they retain the "4-point barb at 5-inch centers" requirement and provided they meet or exceed the strength and coating requirements for the stranded, 12 1/2 gauge, barbed wire as called for in 712.10 of the specifications:

- (a) stranded, 15 1/2 gauge, high carbon steel barbed wire.
- (b) one-strand, 12 gauge, steel barbed wire.

Dome caps for end, corner gate, line or pullposts, shall be swage fitted or securely attached to the posts by means of set screws, pins or rivets.

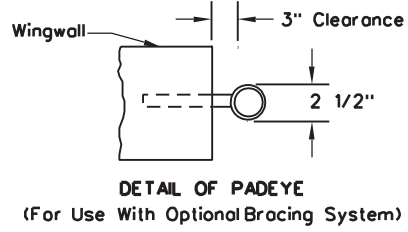

DETAIL OF PADEYE (For Use With Optional Bracing System)

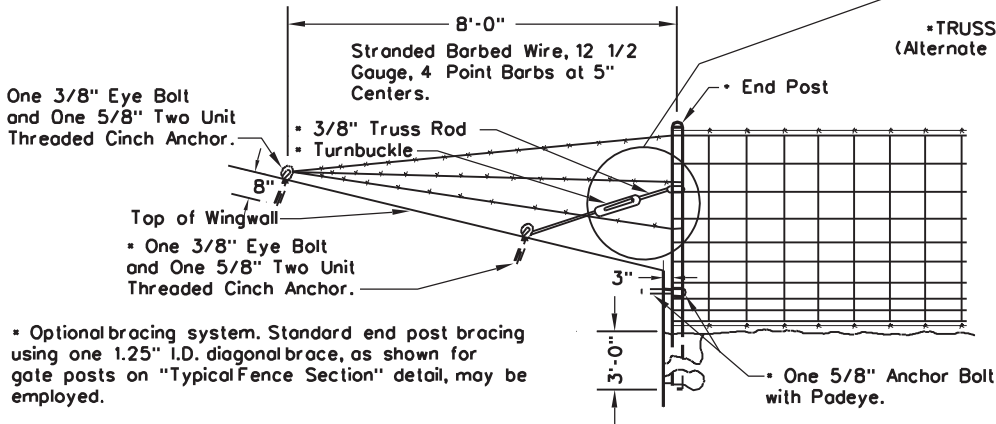

DRAINAGE STRUCTURE TERMINAL INSTALLATION

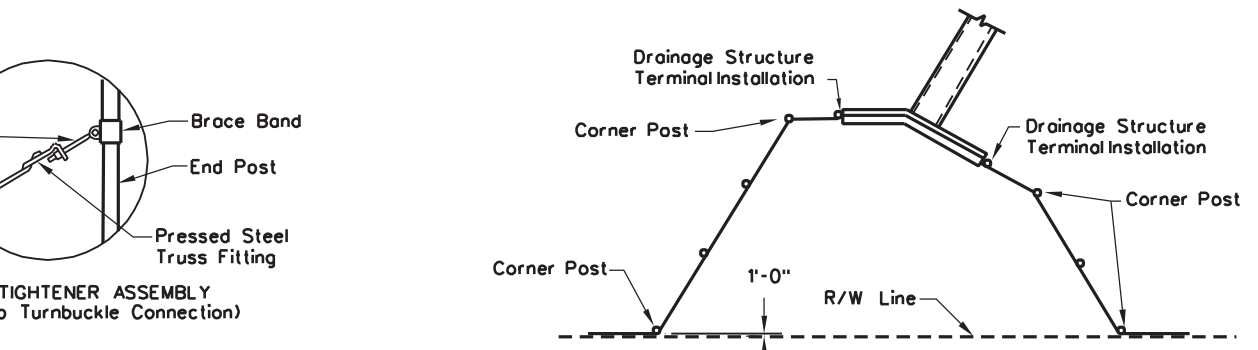

TYPICAL FENCE ALIGNMENT-ANGLE HEADWALLS

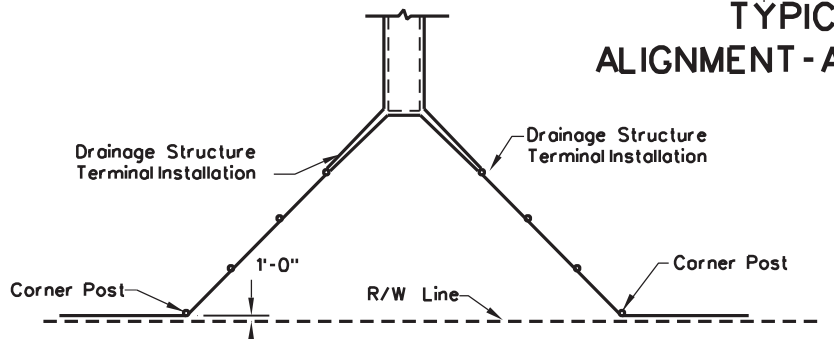

TYPICAL FENCE ALIGNMENT AT WINGWALLS FOR PIPES OR BOX CULVERTS

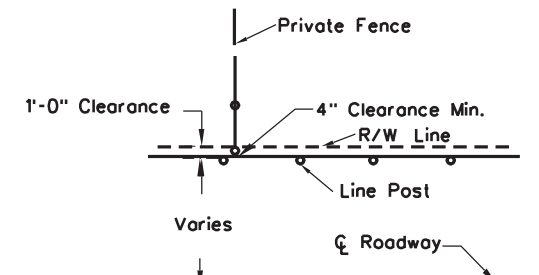

TYPICAL INSTALLATION DIAGRAM

Member Designation	Galvanized Pipe			Triple-Coated Pipe		
	I.D. In.	Wall Thk. In.	Wt. lb/ft.	I.D. In.	Wall Thk. In (min.)	Wt. lb/ft. (min.)
End, Pull, Corner and Intermediate Assembly Post	2	0.154	3.65	2	0.130	3.11
Diagonal Brace	1.25	0.140	2.27	1.25	0.111	1.83
Pedestrian Gate Post	2	0.154	3.65	2	0.130	3.11
Pedestrian Gate Frame	1	0.133	1.68	1	0.104	1.34
Vehicular Gate Post	3.5	0.226	9.11	-	-	-
Vehicular Gate Frame	1.5	0.145	2.72	1.5	0.120	2.28
Special Length Line Post (For over 9'-0")	2	0.154	3.65	2	0.130	3.11

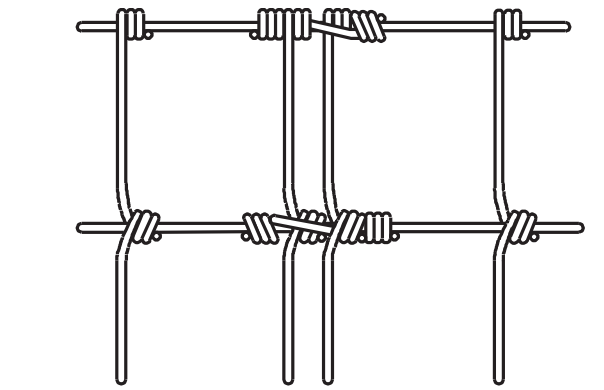

TYPICAL WIRE FENCE SPLICE

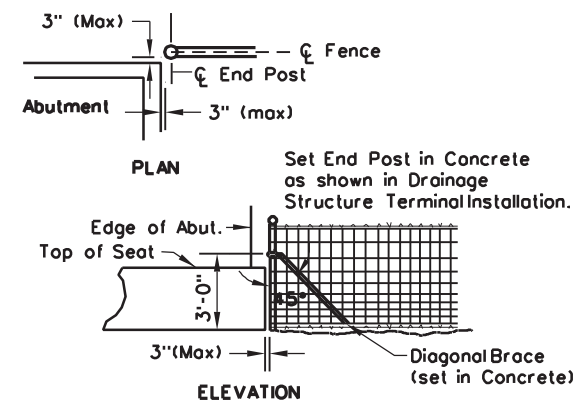

DETAIL OF R/W FENCE AT ABUTMENTS

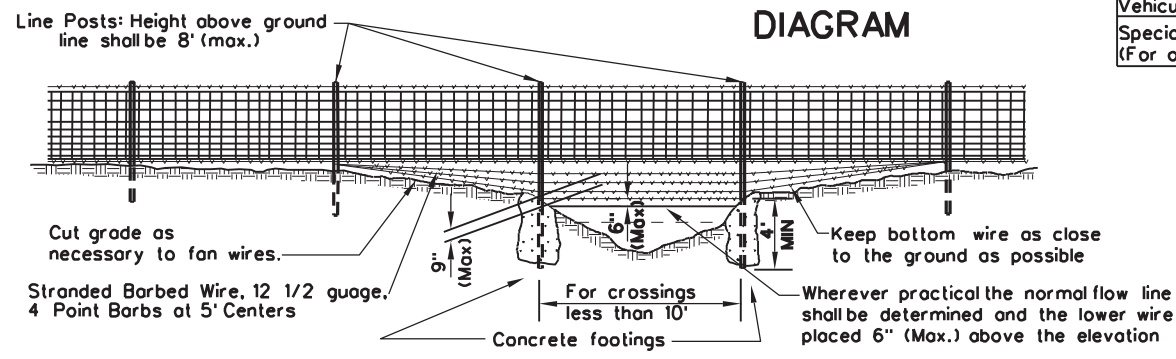

DETAIL SHOWING TYPICAL SECTION AT MINOR DEPRESSIONS AND WET WEATHER CROSSINGS

WEST VIRGINIA DEPARTMENT OF TRANSPORTATION
DIVISION OF HIGHWAYS
STANDARD DETAIL

PREPARED 7-1-99
REVISION DATE

RW FENCE-FARM FIELD WITH STEEL POSTS (3'-11" fence fabric height)

STANDARD SHEET F2

Similar designs meeting the approval of the Engineer may be used.

Pressed Steel

PEDESTRIAN AND VEHICULAR GATE CORNER ATTACHMENT

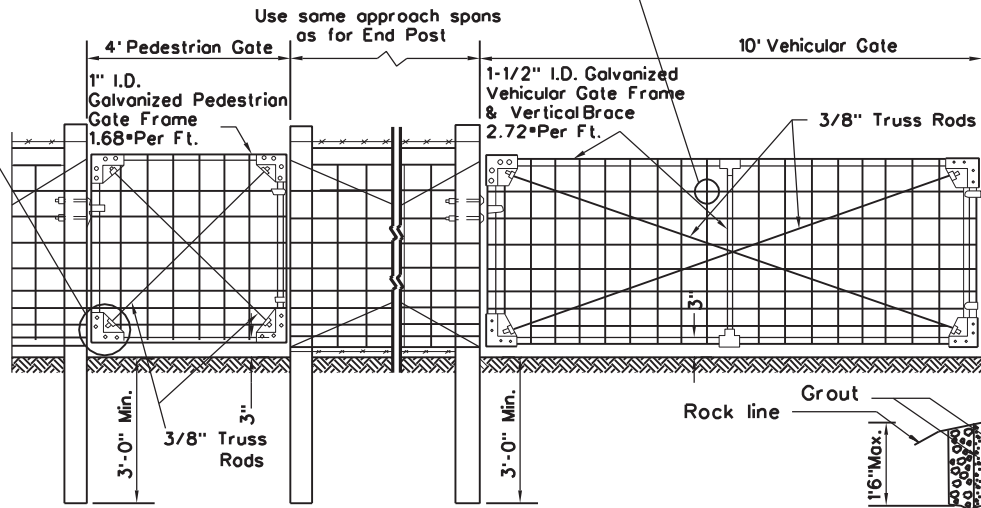

When a portion of any post falls in rock, that portion shall be grouted in place as shown above.

** Barbed wire shall not be used, when so restricted by local ordinances or regulations, and the posts shall accordingly be set deeper into the ground.

Max. Spacing of Line Posts shall be 15'-0\"/>

Use some approach spans as for End Posts
Gate Posts 6\"/>

TYPICAL FENCE SECTION

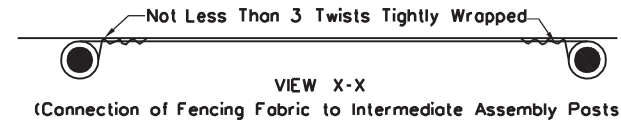

20' with two Approach Posts when more than 300' to next Corner Pull, Intermediate, Gate or End Post.

Approach Post 6\"/>

End Corner, or Pull Posts 6\"/>

* Applies on level terrain, may be adjusted for slope construction.

NOTES:

Posts and braces may be either round or square shaped. Dimensions shown on the Plans are for round posts and braces only. When square posts are used, line posts shall be 3\"/>

The positioning of the fence fabric and barbed wire on the posts, as shown on the "Typical Fence Section" detail, applies for level and gentle sloping terrain. For fence erected on slopes, the positioning may be adjusted to meet the slope conditions as long as the adjustment is continued from post to post in a uniform manner. Trenching on slopes may be warranted. On slopes, posts will continue to be erected vertically, unless otherwise directed, and the ends of the fencing fabric shall be cut on a skew as may be necessary for proper connection to the posts.

Dumped rock channel protection will be used at channel crossings when called for on the plans. Install drainage structure terminal installations as called for on the plans and/or as shown on typical fence details.

Unless otherwise specified, or directed by the Engineer, the farm field fence may be installed with the fence fabric and barbed wire positioned on either side of the fence posts.

Hardware and miscellaneous fittings, not specifically designated herein as to type or dimensions, shall conform to the applicable requirements of Section 608 of the Specifications and shall be of good quality commercial design acceptable to the Engineer.

In lieu of the barbed wire detailed herein, the following additional types are acceptable, provided they retain the "4-point barb at 5-inch centers" requirement and provided they meet or exceed the strength and coating requirements for the standard, 12-1/2 gage, barbed wire as called for in 712.10 of the Specifications:

- (a) stranded, 15-1/2 gage, high carbon steel barbed wire.
- (b) one-strand, 12 gage, steel barbed wire.

Pedestrian and vehicular gate frames (and vertical braces) may be either galvanized steel pipe members as shown herein or may be triple-coated steel pipe members meeting the requirements specified on Standard Sheet F2. All other metal components of the gate shall be galvanized, with the exception of die-cast aluminum corner fittings, or pressed steel corner fittings.

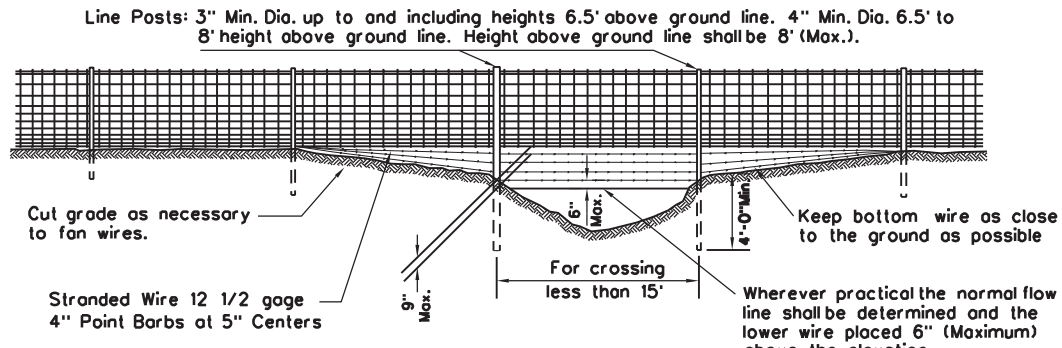

DETAIL SHOWING TYPICAL SECTION AT MINOR DEPRESSIONS AND WET WEATHER CROSSINGS

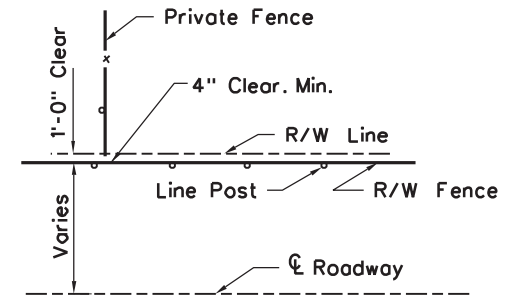

TYPICAL INSTALLATION DIAGRAM

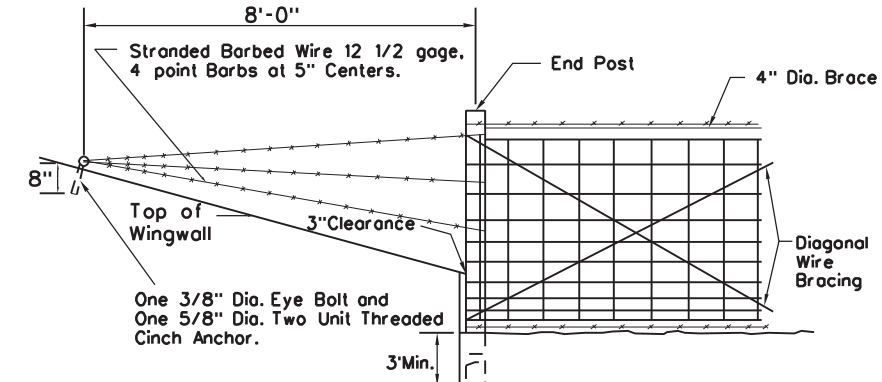

DRAINAGE STRUCTURE TERMINAL INSTALLATION

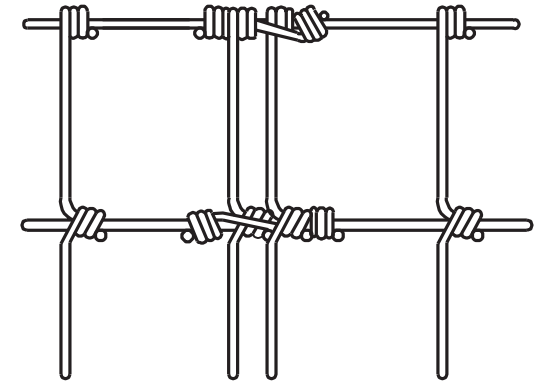

Note: Type FW-4-5 Nicopress Oval Sleeve Wire Splices, or other equal sleeve splices approved by the Engineer, may be used in lieu of the above wrapped wire splices.

TYPICAL WIRE FENCE SPLICE

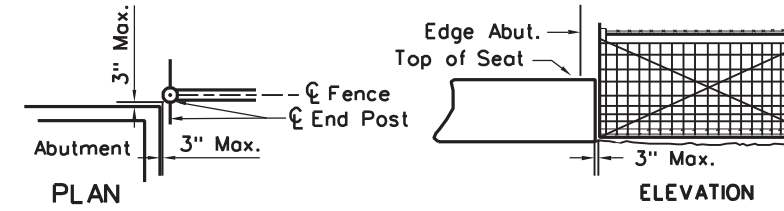

DETAIL OF R/W FENCE AT ABUTMENTS

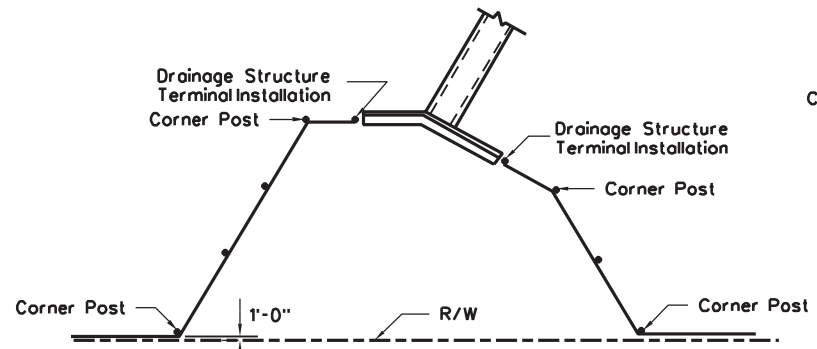

TYPICAL FENCE ALIGNMENT AT ANGLE HEADWALLS

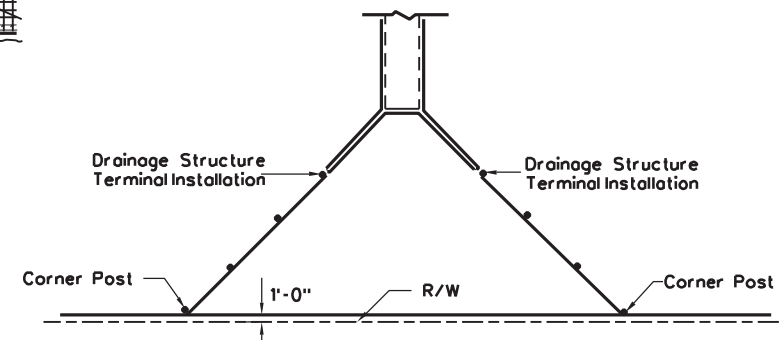

TYPICAL FENCE ALIGNMENT AT WINGWALLS FOR PIPES OR BOX CULVERTS

WEST VIRGINIA DEPARTMENT OF TRANSPORTATION
DIVISION OF HIGHWAYS
STANDARD DETAIL

PREPARED 7-1-99
REVISION DATE

RW FENCE-FARM FIELD WITH TREATED WOOD POSTS (3'-11" fence fabric height)

PROJECT MARKER

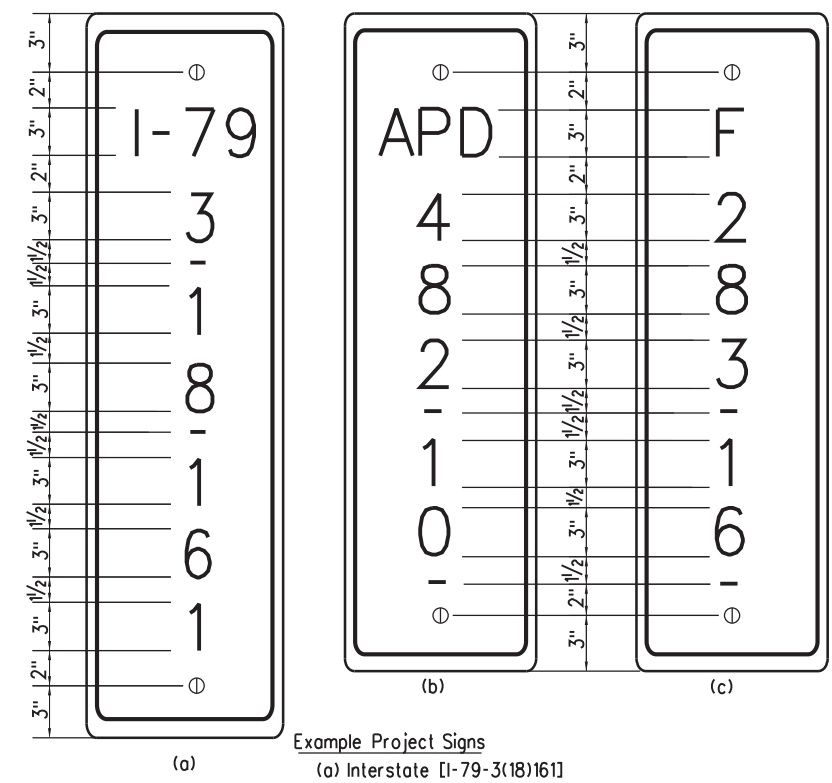
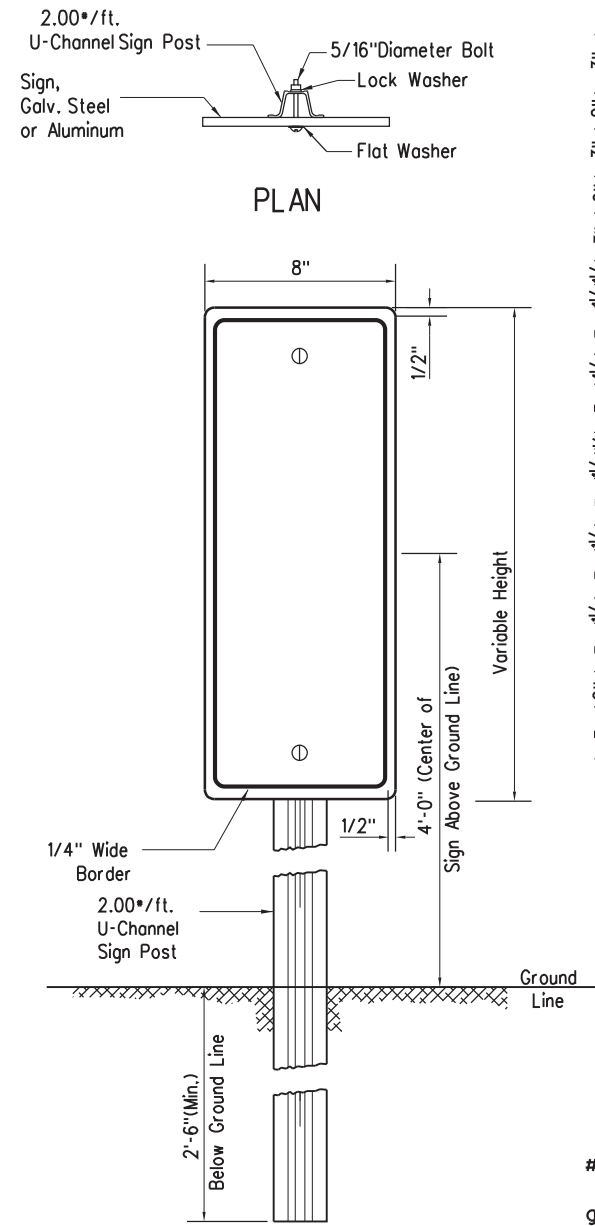

Example Project Signs
 (a) Interstate [I-79-3(18)161]
 (b) Appalachian [APD 482(10)]
 (c) Federal [F-283(16)]

TYPICAL SIGNING DETAILS

NOTES

- Signs shall be fabricated from 0.08" thick aluminum sheets or #16 gauge galvanized steel sheets. Reflectorization is not required.
- Signs shall have black legends and borders on white backgrounds. The letters and numerals are to be of the size and style shown herein.
- U-Channel posts shall meet the requirements of Section 657.2 of the Specifications.
- Steel signs and posts shall be galvanized in accordance with ASTM A-123.
- Steel hardware shall conform with Subsection 709.23 of the Specifications; aluminum hardware with Subsections 709.36 and 709.37. Steel hardware shall be galvanized in accordance with ASTM A-153.
- Top of posts shall extend to the top of signs.
- All posts and signs shall be punched with 3/8-inch holes on their vertical centerlines. Holes shall be so located that the signs can be attached to the posts at three inches below the top of the signs and three inches above the bottom of the signs.

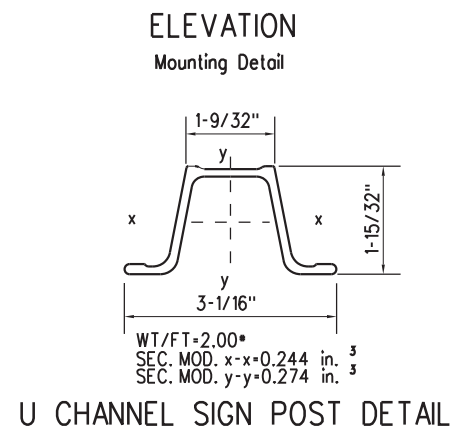

U CHANNEL SIGN POST DETAIL

WEST VIRGINIA DEPARTMENT OF TRANSPORTATION
 DIVISION OF HIGHWAYS
 STANDARD DETAIL

PREPARED 7-1-99

REVISION DATE
9/13/10

MARKERS
 SHEET 1 of 2

STANDARD SHEET M 1

STANDARD SURVEY MARKER

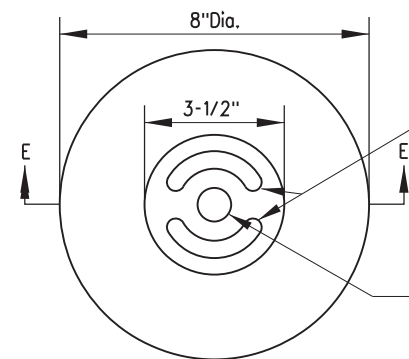

PLAN VIEW

Machine finished, stamped after setting to indicate Control Point, Centerline Stationing & Monument Elevation, or as directed by the Engineer

Mark for alignment reference after setting.

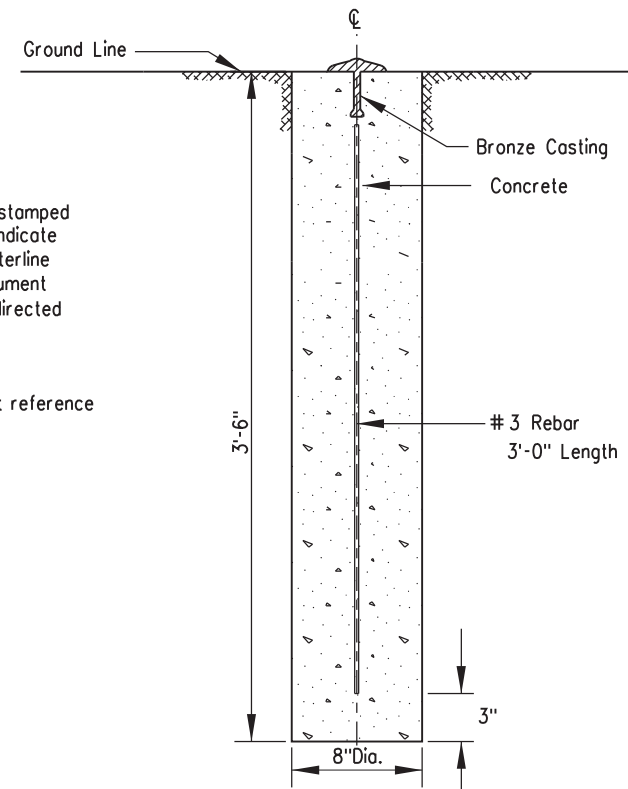

ELEVATION VIEW

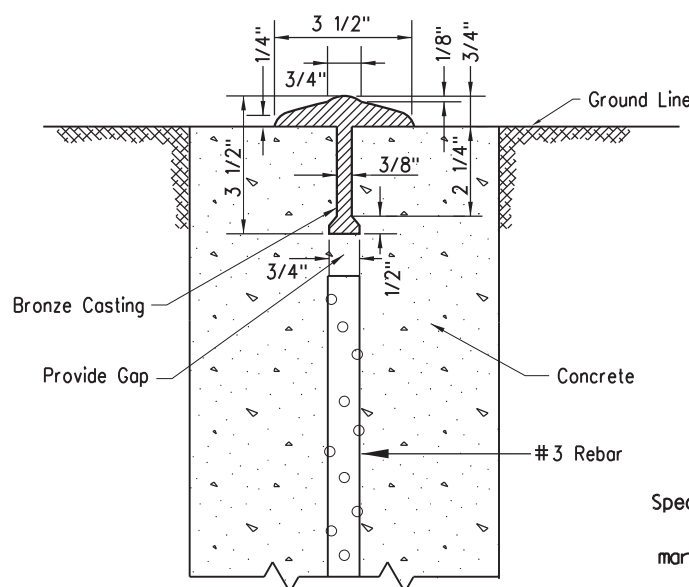

SECTION E-E

NOTES

Survey markers shall conform to the requirements of the Standard Specifications.
Sufficient reinforcement shall be included in precast survey markers to resist handling stresses.

ALTERNATE SURVEY MARKER

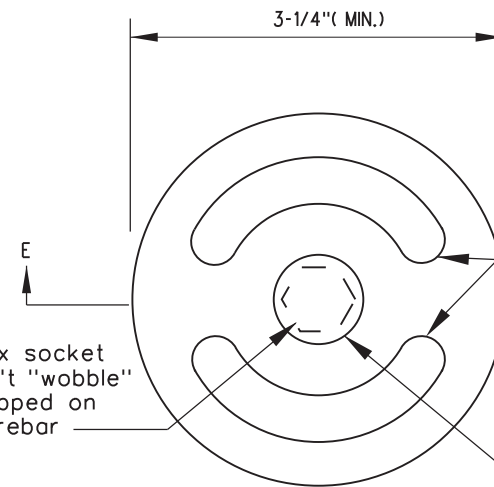

PLAN VIEW

Deep hex socket that won't "wobble" when tapped on to the rebar

Stamped By The Manufacturer to indicate Control Point, Centerline Stationing & Monument Elevation, or as directed by the Engineer

Mark for alignment reference Center punch & cross

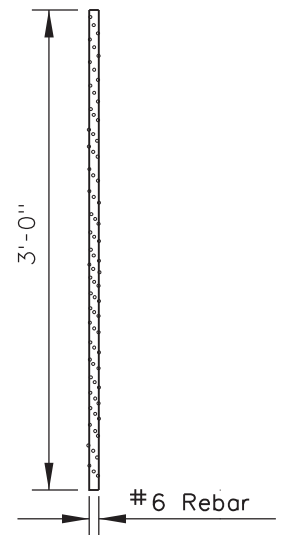

ELEVATION VIEW

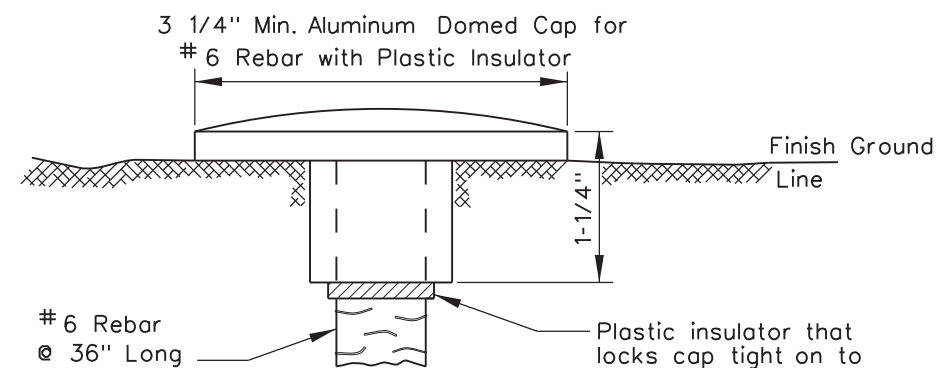

SECTION E-E

Plastic insulator that locks cap tight on to rebar and helps prevent dissimilar metal corrosion.

NOTES

Survey markers shall conform to the requirements of the Standard Specifications.

WEST VIRGINIA DEPARTMENT OF TRANSPORTATION
DIVISION OF HIGHWAYS
STANDARD DETAIL

PREPARED 09-13-10
REVISION DATE

MARKERS

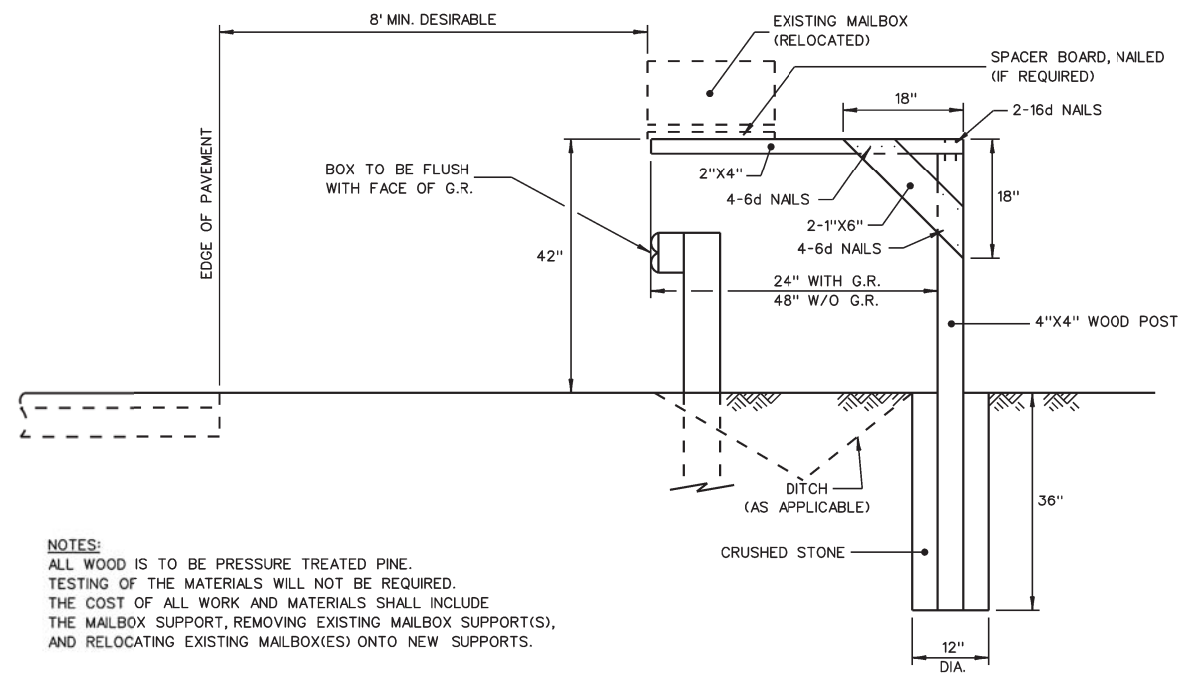

NOTES:
 ALL WOOD IS TO BE PRESSURE TREATED PINE.
 TESTING OF THE MATERIALS WILL NOT BE REQUIRED.
 THE COST OF ALL WORK AND MATERIALS SHALL INCLUDE
 THE MAILBOX SUPPORT, REMOVING EXISTING MAILBOX SUPPORT(S),
 AND RELOCATING EXISTING MAILBOX(ES) ONTO NEW SUPPORTS.

WEST VIRGINIA DEPARTMENT OF TRANSPORTATION
 DIVISION OF HIGHWAYS
 STANDARD DETAIL

CANTILEVER MAILBOX SUPPORT

PREPARED 04/18/14

REVISION DATE

STANDARD SHEET M-2