

DESIGN GUIDE FOR SIGNING

West Virginia Department of Transportation
Division of Highways
Traffic Engineering Division

January 2017



Table of Contents

1.0	GENERAL SIGN PLAN PREPARATION	2
1.1	General.....	2
1.2	Steps in Preparation of Signing Plans	3
2.0	SIGNING	7
2.1	General Signing.....	7
2.2	Regulatory Sign Use and Location	7
2.2.1	Speed Limit (R2-1) Signs.....	7
2.2.2	EMERGENCY STOPPING ONLY (R8-7).....	8
2.2.3	Authorized Vehicle Crossovers (R3-4 and R8-12 Signs).....	10
2.2.4	Signing for Truck Climbing Lanes (R4-6 and R4-3 Signs).....	10
2.2.5	Signing for LEFT LANE NO TRUCKS (R4-5A, R4-5B, and R4-5C Signs).....	10
2.2.6	Regulatory Signing for Expressway Intersections and Ramp Terminals (R1-1, R1-2, R4-7, R4-8, R5-1, R5-1A, R5-4, R6-1, R6-3 Signs).....	13
2.2.6.1	R1-1, R1-4, R1-12/R1-10P, R3-2R, R6-3, R6-3A.....	13
2.2.6.2	Yield (R1-2) and TO ONCOMING TRAFFIC (R1-13)	13
2.2.6.3	Keep Right (R4-7)	18
2.2.6.4	One Way (R6-1), Wrong Way (R5-1A) and Do Not Enter (R5-1).....	18
2.2.7	Two-Way Left Turn Only Lane Signing (R3-9B, R3-9C, and R3-9E).....	18
2.2.8	Lane Control Signing (R3-5, R3-5A, etc.)	23
2.2.9	Roundabout Signing (R6-4A, R6-4B, R1-2 and R3-8).....	23
2.2.10	Exclusion Signing (R5-5F, R5-5P, R5-5R, and R8-11A)	23
2.2.11	Turn Restriction Signing (R1-12, R3-1, R3-2, R3-3, R3-4, R3-7L, R3-7R)	23
2.2.12	Signing for Mandatory Truck Brake Check Areas (R13-2A, R13-2B, R13-2C, D5-13, D5-14)	26
2.2.13	No Parking Signs (R8-3A)	26
2.2.14	Continuous Lanes through Signalized Intersections (R4-15 and R4-16).....	26
2.3	Warning Sign Use and Location	26
2.3.1	Function of Warning Signs.....	27
2.3.2	Enhancing Visibility and Emphasis of Warning Signing.....	28
2.3.3	Intersection Advance Warning Signing W2-1, W2-2, W3-1, and W3-2.....	28
2.3.4	Roadway Condition Signing W8-14	29
2.3.5	Horizontal Alignment Signing	29
2.3.5.1	Horizontal Alignment Warning Signs (Curve Signing W1-X).....	29
2.3.5.2	Exit Ramp Horizontal Alignment Warning Signs (W13-2 and W13-3).....	30
2.3.5.3	Chevron Alignment Signs (W1-8)	31
2.3.5.4	Merge Sign (W4-1 or W4-3)	31

2.3.5.5	Signing for Roadway Transitions.....	31
2.3.5.5.1	Reduction in Traffic Lanes (W9-1R or L, W4-2R or L).....	31
2.3.5.5.2	Ending of Four Lane Highways other than Freeways and Expressways (W4-2L, W5-7, W5-7A, W6-1, W6-2, W6-3, W9-1L, R4-1, R4-7A, R4-7C)	32
2.3.5.5.3	Signing for Freeway or Expressway Ending (W17-9, W17-9A, W9-1L, W5-7A, W4-2L, W5-7, R4-7A, R4-7C, R4-1, and W17-8).....	32
2.3.5.6	Signing for Steep Downgrades (W7-1B, W7-3A, and W7-2)	32
2.3.5.7	Signing for Freeway Merge Areas.....	33
2.3.5.8	Signal Ahead Signs and Flashers on Expressways (W3-3, W3-3F and W2-1F)	33
2.3.5.9	Overhead Clearance Signing (W12-2 and W12-2P)	38
2.3.5.10	Crossing Signing (W11-1, W11-2, W11-3, W11-4, W11-5, W11-7, W11-7A, W11-11, W11-12, and W7-3A).....	38
2.3.5.11	Bike Lanes, Routes, and Paths (W11-1, W11-1A, R3-17, R3-17A, R3-17B, D11-1, D11-1A, and D11-1B).....	39
2.3.5.12	Object Marker Signing (XS-2 AND XS-15).....	39
2.3.5.13	Railroad Crossing Signing (W10-1, W10-2, W10-3, W10-4, and W10-5).....	39
2.4	Guide Signs on Conventional Roads	40
2.4.1	General Requirements	40
2.4.2	Route Signing.....	40
2.4.2.1	Route Sign Assemblies (M1-1, M1-4, and M1-6).....	40
2.4.2.2	Confirming Assemblies (M3-1 through M3-4, M1-4, and M1-6)	40
2.4.2.3	Junction Assembly (M2-1, M1-1, M1-4, and M1-6)	40
2.4.2.4	Other Auxiliary Route Signs.....	41
2.4.2.5	Directional Assemblies.....	41
2.4.3	Route Markers and Arrow Arrangement	44
2.4.4	Guide Signs	44
2.4.4.1	Destination Signs (D1-1, D1-2 or D1-3).....	44
2.4.4.2	Distance Signs (D2-1, D2-2 or D2-3).....	46
2.4.4.3	County Road Name Signs (D16-1, 2, or 3).....	46
2.4.4.4	Street Name Signs (D3-1)	46
2.4.4.5	Supplemental Destination Signs (AE5-1) Signs	46
2.4.5	Guide Signing on Conventional Roads on approaches to Interchanges	47
2.4.5.1	Signing on Conventional Roads having one lane of traffic approaching Interchanges	47
2.4.5.2	Signing on Conventional Roads having multiple lanes of traffic approaching Interchanges.....	47
2.4.5.3	Junction Assembly	48
2.4.5.4	Advance Directional Assembly.....	48
2.4.5.5	Advance Entrance Direction Sign (AE2-4A).....	48

2.4.5.6	Entrance Direction Sign (AE1-4A).....	48
2.4.5.7	Freeway Entrance Ramp Sign Assembly.....	49
2.4.6	Guide Signing Along WV and US Highways on Approaches to Intersections.....	49
2.4.6.1	Guide signing along two lane highways for all intersections with roads having a county route number and name.....	49
2.4.6.2	Signing on WV and US roads having one or more lanes of traffic approaching an intersection with a WV or US signed route.....	49
2.4.7	Supplemental Guide Signing and Destination Trailblazing on Non-Expressways.....	50
2.4.8	Destination Signing for County Routes on Non-Expressways.....	50
2.4.9	Byway and Backway Signing (D-24 and D-24A).....	51
2.4.10	Street Name Signs/Internally Illuminated LED (D3-1).....	51
2.4.11	Motorized Recreational Trail Signing (D27).....	51
2.5	Guide Signing on Freeways and Expressways.....	52
2.5.1	Guide Sign Legend.....	52
2.5.2	General Requirements for Signing Freeway and Expressway Interchanges.....	60
2.5.2.1	Classification of Interchanges.....	60
2.5.2.1.1	Major Interchange.....	60
2.5.2.1.2	Intermediate Interchange.....	60
2.5.2.2	Signing for Freeway Junctions.....	60
2.5.2.3	Signing for Major Interchanges.....	61
2.5.2.4	Signing for Intermediate Interchanges.....	61
2.5.3	General Requirements for Signing Intersections.....	61
2.5.3.1	Major Intersection.....	61
2.5.3.2	Intermediate Intersection.....	62
2.5.3.3	Minor Intersection.....	62
2.5.3.4	Land Access Intersection.....	62
2.5.3.5	Signing For Major Intersections on Expressways.....	62
2.5.3.6	Signing for Intermediate Intersections on Expressways.....	65
2.5.3.7	Signing for Minor Intersections on Expressway.....	65
2.5.3.8	Signing for Land Access Intersection on Expressways.....	65
2.5.4	Freeway and Expressway Guide Sign Use and Location.....	70
2.5.4.1	General Requirements.....	70
2.5.4.2	Two Mile Sign (AE3-2 Major Guide Sign).....	70
2.5.4.3	One Mile Sign (AE3-1 Major Guide Sign).....	70
2.5.4.4	One-Half Mile Sign (AE2-2 Major Guide Sign).....	72
2.5.4.5	Exit Direction (AE2-1 Major Guide Sign).....	72
2.5.4.6	Exit Gore (E5-1 and E5-1A).....	72

2.5.4.7 Interchange Sequence Sign (AE6-1 Major Guide Sign).....	72
2.5.4.8 Intersection Sequence Sign (AE6-1 Major Guide Sign for Expressways Only).....	73
2.5.4.9 Next X Exits Sign.....	73
2.5.4.10 Post Interchange and Intersection Signs.....	73
2.5.4.10.1 Confirming Assembly.....	73
2.5.4.10.2 Speed Limit sign (R2-1).....	73
2.5.4.10.3 Distance Sign (D2-2, or 3) (Not Major Guide Sign).....	74
2.5.4.10.4 Emergency Stopping Only Sign (R8-7).....	74
2.5.4.11 Other Guide Signs at Interchanges and Intersections on Freeways and Expressways.....	75
2.5.4.11.1 Ramp Directional Signs.....	75
2.5.4.11.2 Junction Guide Sign (AD5-5).....	75
2.5.4.11.3 Advance Directional Assembly.....	75
2.5.4.11.4 Destination Sign (D1-2 or 3).....	76
2.5.4.11.5 Final Directional Assembly.....	76
2.5.4.11.6 Advance Intersection Sign (AD1-2).....	76
2.5.4.11.7 Intersection Direction Sign (AD2-2).....	77
2.5.4.11.8 Freeway Entrance Ramp Sign Assembly (M8-1).....	77
2.5.5 Supplemental Guide Signs on Freeways and Expressways.....	77
2.5.5.1 Supplemental Destinations.....	77
2.5.5.2 Traffic Generators.....	78
2.5.6 Rest Area and West Virginia Welcome Center Signing (D5-1, D5-1A, D5-1B, D5-2, and D5-6).....	78
2.5.7 Weigh Station Signing (D8-1, D8-2, D8-3, and R13-1).....	81
2.5.8 Runaway Truck Ramp Signing (W7-4, W7-4A, W7-4B, and W7-1B).....	81
2.5.9 Guide Signing for Toll Facilities (M4-14).....	81
2.5.10 Interchange Exit Numbering and Reference Location Signs (D10C, D10F, D10-1FR, and D10-1CR).....	84
2.5.11 Overhead Sign Installations.....	84
2.5.12 Left Exit Panels (E1-5A, E1-5B, E1-5C, and E1-5P).....	85
2.5.13 Interchange Lane Drop Signing.....	85
2.5.14 Boundary Line Signs.....	88
2.5.14.1 State Line Signs (I2 and I2A).....	88
2.5.14.2 County Line Signs (I27 and I27A).....	90
2.5.14.3 City Limit Sign (I-40).....	90
2.5.14.4 City or Town Name Sign (I-25).....	90
2.5.14.5 Unincorporated Community Name Sign (I-26).....	90
2.5.14.6 Multiple Boundaries.....	90
2.5.14.7 Stream Name Sign (I-3B, C, D, and E, and I-50A).....	92

2.5.15	Park and Ride Signing (D4-2)	92
2.5.16	Recreational Facility Signing	92
2.5.17	Specific Motorist Service Signing and TODS/LOGO Signing	93
2.5.17.1	TODS/LOGO Signing for Interstate Highways	93
2.5.17.2	TODS/LOGO Signing for Expressways	93
3.0	SCHOOL SIGNING	94
3.1	School Zone Signing	94
3.2	School Crossing Signing	94
3.3	School Area Signing	97
3.4	School Bus Stop Signing	97
3.5	School Bus Entering Signing	97
3.6	Reflective Sign Support Strips for School Signing	97
4.0	DELINEATION	97
5.0	SIGN VERTICAL AND LATERAL CLEARANCE	100
5.1	Sign Vertical Clearance	100
5.2	Sign Lateral Clearance	100
6.0	SIGN SUPPORTS	100
6.1	Ground Mounted Sign Supports	100
6.1.1	Design of Ground Mounted Sign Supports	103
6.1.2	Examples of Designing Sign Supports and Foundations	103
6.2	Overhead Sign Supports	104
6.3	Foundations	104
6.4	Renovation Projects	105
7.0	SIGN LIGHTING	105
8.0	DESIGN OF SIGNS	106
8.1	Sign Materials	106
8.1.1	Sign Substrate	106
8.1.2	Sign Sheeting	106
8.1.3	Sign Legend	106
8.1.4	Sign Borders and Corner Radii	107
8.2	Designing Guide Signs/Determining Sign Message	107
8.2.1	Legend Size and Spacing	107
8.2.2	Rules for Sign Text Spacing	107
8.2.3	Items Needed in Signing Plans	108
8.2.4	Estimate and Summary of Quantities	108
	Index	111

List of Figures

Figure 1 – Signing for Speed Limits and Speed Zones	9
Figure 2 – Authorized Vehicle Crossover Signing.....	11
Figure 3 – Signing for Truck Climbing Lane	12
Figure 4 – Regulatory Signing at Cross Road Medians Less Than 30 Feet	14
Figure 5 – Regulatory Signing at “T” Intersection Medians Less than 30 Feet	15
Figure 6 – Regulatory Signing at “T” Intersection Medians 30 Feet or Greater.....	16
Figure 7 – Regulatory and Warning Signing within a Major or Intermediate Interchange.....	17
Figure 8 – Signing for Two Way Left Turn Lane on Three Lane Highway.....	19
Figure 9 – Signing for Two Way Left Turn Lane on Five Lane Highway.....	20
Figure 10A - Turn Restrictions and Lane Control Signs.....	21
Figure 10 – Signing for Continuous Through Lane at Signalized Intersection.....	22
Figure 11 A – Signing for Single Lane Roundabout.....	24
Figure 11 B – Signing for Multi Lane Roundabout.....	25
Figure 12 – Signing for Mandatory Truck Stop on Two Lane Highways	34
Figure 13 – Signing for Mandatory Truck Stop on Freeways and Expressways	35
Figure 14 – Typical Layout for Advisory Curve Signing.....	36
Figure 15 – Exit Ramp Horizontal Alignment Signs.....	37
Figure 16 – Signing for Lane Transition and Begin & End Divided Highway.....	42
Figure 17 – Signing for Freeway or Expressway Ending.....	43
Figure 18 – Signing for Steep Downgrades	45
Figure 19 – Signing for Freeway Merge Area	53
Figure 20 – Signing on a WV Route on Approach to an Intersection with an Expressway	54
Figure 21 – County Road Name Sign and Supplemental Guide Signing on Non-Expressways.....	55
Figure 22 – Signing on a WV Route Having Multiple Lanes Approaching Interchange	56
Figure 23 – Byway Signing.....	57
Figure 24 – Freeway Junction Signing Left Exit Example.....	58
Figure 25 – Signing for an Interchange Lane Drop with Option Lane	59
Figure 26 – Major or Intermediate Interchange Signing.....	63
Figure 27 – Signing for a Major Intersection on an Expressway	64
Figure 28 – Signing for an Intermediate Intersection on an Expressway (ADT Greater than 1000).....	66
Figure 29 – Signing for an Intermediate Intersection on an Expressway (ADT 250 to 1000).....	67
Figure 30 – Signing for an Minor Intersection on an Expressway (ADT Less than 250).....	68
Figure 31 – Signing for Land Access Intersection on Expressway.....	69
Figure 32 – Guide Signing within a Major or Intermediate Interchange with a Two-Lane Crossroad	71
Figure 33 and Figure 34 – Welcome Center and Rest Area Signing on a Freeway.....	79

Figure 35 – Signing within a Rest Area and Welcome Center.....	80
Figure 36 and Figure 37 – Weigh Station Signing on a Freeway and Signing within a Weigh Station	82
Figure 38 – Runaway Truck Ramp Signing	83
Figure 39 – Interchange Single Lane Drop with Option Lane	86
Figure 40 – Interchange Single Lane Drop without Option Lane.....	87
Figure 41 – Miscellaneous Signs at State line on Freeways.....	89
Figure 42 – Miscellaneous Signs at County Line on Freeways and Expressways	91
Figure 43 – Park and Ride Signing.....	95
Figure 44 – Typical Signs and Markings for School Zone with Flashing Beacons.....	96
Figure 45 – School Area Signing on an Expressway.....	98
Figure 46 – Examples of Vertical & Horizontal Locations of Sign Installations.....	101
Figure 47 – Typical Signing Layout for Minor Rural Intersections.....	102
Figure 48 – Signing Estimate of Quantities.....	109
Figure 49 – Delineation Estimate of Quantities	110

List of Tables

Table 1 - Guidelines for Advance Placement of Warning Signs	27
Table 2 - Horizontal Alignment Sign Selection.....	30
Table 3 - Guidelines for Delineator Spacing.....	99

Appendices

APPENDIX A – Sign Design Guidelines

APPENDIX B – Traffic Engineering Directive 220-1

FOREWARD

This January 2017 edition of the Design Guide for Signing has been issued with the intent that it be used on all projects in which bids are received after January 2017. This book has been prepared to provide a compilation of sign design guidelines for use in all West Virginia Division of Highways design and construction contracts. An effort has been made to include all of the sign design guidelines in effect at this time. The sign design guidelines contained in Design Guide for Signing may be amended from time to time by Traffic Engineering Directives, Design Directives, Supplemental Specifications or by Special Provisions applicable to the specific contract. Reference, by title and date, will be made to the governing provision on Plans or Contract Documents.

This Design Guide for Signing Manual was prepared by **ms consultants, inc.** for the West Virginia Division of Highways (WVDOH) Traffic Engineering Division. This manual is intended to be a guide for Engineers and Designers preparing signing plans for the WVDOH or for District Traffic Engineers preparing plans or installing signing. It provides policies, procedures, and methods for developing and documenting the design process. It also provides standards, guidelines, and details for design and installation of signing. While it is not intended to replace the engineering analysis and judgment that must be applied to each project, adequate documentation should be provided for any deviation from the standards and guidelines in this manual. The benefits of this Manual will be the standardization of the sign design process, common details, and the layout of the contract plans. In addition, it will provide minimum design standards for signing installed in West Virginia and provide interpretation and consistency in the application of the procedures in the national Manual on Uniform Traffic Control Devices.

The layout of the Design Guide for Signing Manual generally follows the outline of the national Manual on Uniform Traffic Control Devices. Section 1.0 is a general discussion of preparation of contract signing plans and Section 2.0 is a general discussion of signing. In addition Section 2.2 is a discussion of Regulatory Signing, Section 2.3 is a discussion of Warning Signing, Section 2.4 is a discussion of Guide signs on conventional roads, and Section 2.5 is a discussion of Guide signing on freeways and expressways. School signs are discussed in Section 3.0, Delineation is discussed in Section 4.0, Vertical and lateral sign clearance are discussed in Section 5.0, and Sign supports are discussed in Section 6.0. Sign lighting is discussed in Section 7.0 and Design of Signs is discussed in Section 8.0. Finally, Appendix A provides detailed information about Design of guide signs and Appendix B provides a listing of destinations for routes in West Virginia. All sign dimensions are in inches unless otherwise noted.

Revisions to this Manual will be made on a regular basis. The revisions will be handled as interims and the Manual will be republished as deemed necessary by the WVDOH.

1.0 GENERAL SIGN PLAN PREPARATION

1.1 General

The purpose of this manual is to consolidate all information dealing with design or installation of signing on West Virginia Highways into one reference and to update this manual to reflect and support the latest changes in the MUTCD, to reflect changes to Traffic Engineering Directives, and to reflect current policy. This manual supersedes all previous printed material concerning this subject.

All signs, signing plans, and sign structures shall conform to the design guidelines set forth herein by the West Virginia Division of Highways. In addition to these criteria, the latest editions of the following listed publications shall be used where deemed applicable by the Division of Highways in the design of signs, signing plans, and sign structures:

1. West Virginia Standard Specifications for Roads and Bridges (2010 with latest updates referred to as the Standard Specifications).
2. West Virginia Division of Highways Sign Fabrication Details (2005 referred to as the Fabrication Manual).
3. AASHTO Standard Specifications for Structural Supports for Highway Signs, Luminaires and Traffic Signals (referred to as the AASHTO Support Specifications).
4. Manual on Uniform Traffic Control Devices for Streets and Highways, (2009 with updates) as approved by the Federal Highway Administration (referred to as the MUTCD).
5. West Virginia Division of Highways Standard Details Book Volume 2 for Signing, Signals, Lighting and Marking (referred to as Volume 2) (2017).
6. Traffic Engineering Directives (2011).
7. Roadside Design Guide (2011).

Where this manual conflicts with any federal standard publications, including MUTCD, the federal requirements shall always supersede this design guide and any other state-published standard.

This Design Guide for Signing is intended to cover five categories of highways:

- Fully controlled access - freeways (interstate highway)
- Partially controlled access - expressways (Appalachian Corridors D-US 50, G-US 119, H-US 48, L-US 19, Q-US 400, and certain other four lane expressways such as US 35 and US 22)
- Four-lane highways with design speeds > 40 MPH (Example: US 60 from Malden to Diamond)
- Two-lane highways with design speeds > 50 MPH. (Example: WV 2 south of Point Pleasant, WV 94 Charleston to Marmet, US 52 south of Kenova)
- Conventional roads - as detailed in MUTCD. (Example: WV 114 from Charleston to I-79)

For the purpose of this manual, fully-controlled access facilities shall be freeways where the only access points are by interchanges; partially-controlled access facilities shall be all expressways where abutting property owners have no legal right of access to or from the roadway except at points designated by the Division of Highways (DOH). All access points to expressways are limited to intersections or interchanges constructed by the DOH in the development of the expressway or those intersections constructed by commercial, residential, or industrial developers to DOH standards and with DOH approval

1.2 Steps in Preparation of Signing Plans

A general outline of the sequence of events in the preparation of sign plans is as follows. There will be five separate submissions of plans. These submissions are as follows; Preliminary Field Review and/or inventory plan, Final Field Review, Office Review, Check Print Review, and PS & E Review:

Step 1

- A. When road names, route numbers, or average daily traffic (ADT) are needed they may be obtained from Traffic Analyses Section of Planning Division. The Geospatial Transportation Information Section can provide road names and route numbers for county routes. The Traffic Analysis section can provide ADT's. Determine what types or classes of intersections and/or interchanges exist on the facility in accordance with Section 2.5.2 and 2.5.3 discussed later in this Manual.
- B. Determine the type of construction: new road, roadway improvement, or sign renovation.
- C. Determine the names and route numbers to be used for each interchange and intersection. A determination must also be made whether supplemental signs, LOGO (specific motorist services signing) and TODS (Tourist Oriented Directional Signing) are needed.
- D. Aid in the determination of the guide sign legend can be found in Section 8 of these criteria and in Appendix A.

Step 2

Prepare a scaled base map showing all roadways to be signed and the right-of-way lines, including stationing. Include proposed detail such as guardrail, light poles, MSE walls, and other pertinent features. Through roadway scales on Interstate and expressway mainlines should be 1" = 200' with two sections per sheet where possible. Interchanges, smaller expressways, or short sections of Interstate Mainline should have a scale of 1" = 100', depending on the amount of signing to be shown. Urban areas and highways with frequent intersections should be 1" = 100'; interchange crossroad areas and congested intersections should be 1" = 100' with 1" = 50' used only for especially congested areas.

Determine the type of signs to be erected for each class of interchange and intersection in accordance with Sections 2.4 and 2.5.

Step 4

Using Sections 2.2 through 3.0 of this publication on the uses and locations of signs, place all guide, regulatory, warning, service, and school signing on the base map at the proper location and shown facing

the traffic the signs are intended to serve with all proposed legend shown. The base map shall include the roadway, intersections, driveways to major commercial or industrial facilities, and interchanges. The Preliminary Field Review plans shall contain the following: station number, inventory data (for renovation projects), sign information (message, size, location, condition, reflectivity of certain signs (see notes below under Step 7), material, support, guardrail, etc.), date, clearance/offset, pictures, overhead structures (pictures, visual inspection), supports (type, condition, saw-cut, post spacing, etc.), guardrail (regular or cable) information (show them on the plans), sign legend (size and type), right of way line, any existing traffic signal and lighting poles, any existing visible utilities (overhead and junction boxes), etc. GPS coordinates of overhead signs shall be included in the inventory of all existing overhead signs. Tentative and proposed power sources and voltages should be obtained for sign lighting. Additional data beyond “Project Limits” may be required for any type of signing project constructed near an existing facility. At this point, these plans shall be submitted for review and revision before proceeding to subsequent steps. Note that for sign renovation projects it is necessary to identify the type, location, and condition of existing signs and supports. This is not necessary for construction projects on a new alignment.

Step 5

Once Review comments have been received, design all guide signs and service signs using Section 8.0, and prepare guide sign fabrication sheets. See Figure 50 for an example of this submission. Show no more than four details per sheet. Sign base layout (revised if necessary) along with fabrication sheets are then submitted for review.

Step 6

Using Sections 6, 7, and 8 along with Standard Details TE1-3A, TE1-3B, TE1-3C, TE1-7A, TE1-7B, TE1-7C, and others as necessary begin preparation of the Estimate of Quantities Sheets. See the examples on Figures 46 and 47. Begin by numbering all sign assemblies (all signs on one overhead structure shall have the same assembly number with individual signs (numbered left to right) on the assembly labeled A, B, C, etc.). Place a standard number showing the location of the sign by station number (or some other means), and show the size and type of sign and supports. The support design makes use of the Standard Details and the Standard Specifications as well as material in this publication. Overhead sign supports including any necessary overhead schematic, special bridge wall or median attachments, and sign lighting are designed/detailed at this time. A summary of quantities sheet with appropriate bid items, a title sheet (if needed), and a general notes sheet shall be prepared. This material should then be submitted to the DOH for Final Field Review.

GPS (Global Positioning System) coordinates for ancillary structures, such as overhead sign structures, should be taken at the location of the upright for structures having a single upright or pole. For span type overhead structures, the GPS coordinates should be taken at the right most upright or pole. For span structures that span over two directions of travel, the right side should be determined from the perspective of facing the structure in the primary direction of travel. For north/south routes, the primary

direction shall be northbound. For east/west routes, the primary direction shall be eastbound. This same convention should be used for such structures that span over adjacent interchange ramps. For example, the right upright of a span structure spanning over a southbound exit ramp and a northbound entrance ramp that terminate/begin in the same quadrant should be determined by facing the structure in the normal direction of travel on the northbound entrance ramp. In cases where the structure spans over a roadway with overlapping routes, the right side should be determined by facing the structure in the primary direction of travel for the route having the higher precedence. Interstate routes have a higher precedence than all other routes, U.S. routes have a higher precedence than all other routes except Interstates, and W.V. routes have a higher precedence than secondary local service roads only. Among roadways of the same type, the route having the lower number takes precedence. In the case of structures whose horizontal components would normally be attached to a upright or pole, but are instead attached directly to another structure such as a concrete retaining wall, the GPS coordinates should be taken directly below the connection point for the horizontal components. For frame type overhead sign structures mounted to bridge fascia, bridge trusses, or to the concrete above a tunnel portal, the GPS coordinates should be taken from directly below the front face of the signs at the approximate lateral midpoint of the frame. Coordinates shall be reported in decimal format to six (6) decimal places. For example, 38.336264, 81.612244.

Step 7

Plans shall be revised in accordance with comments derived from the Final Field review, and then the Final Office Review plans shall be submitted. The Final Office Review plans shall include general notes, Temporary Traffic Control Plans, Summary, Estimate sheets, delineator estimate, layout sheets, fabrication sheets, miscellaneous details (if any), overhead sign schematics, sign lighting power service detail, guardrail details (if any), etc. GPS coordinates of overhead signs shall be included in the inventory of all existing overhead signs. GPS coordinates shall be in the degree and decimal format with accuracy to five (5) decimal places. Once comments have been received and incorporated a Check Print Review is held prior to the PS & E submission. A Check Print Review is required on renovation projects and at the discretion of Traffic Engineering Division on other projects. A Check Print Review is usually not required if Traffic Engineering Division Personnel have reviewed prior submissions, and the comments have been appropriately incorporated prior to the PS&E submission. Altogether, the Traffic Engineering Division wants to see plans at least three times before the PS & E submission. The PS & E submission shall include corrected plans in both paper (11 x 17 size) and digital format for contract letting. Additional corrections may be required prior to letting, and any such corrections shall be resubmitted in paper and digital format, with addendums identified as such.

WVDOH SIGN RETRO-REFLECTIVITY TESTING GUIDELINES

1. Testing will be accomplished using a retro-reflectometer.
2. Field procedure shall be done using the following protocol:
 - a. Testing shall be performed in dry conditions;
 - b. Type of sheeting shall be determined;
 - c. Four readings shall be taken on each retro-reflective color on the sign;
 - d. Each sign in an assembly shall be tested;
 - e. Readings shall not be taken where there are holes, paint ball marks, graffiti or other damage;
 - f. Readings shall be recorded in a format based on the sign numbering used for the inventory plans;
3. The retro-reflectivity of the following signs shall not be measured:
 - a. Mile markers and ramp markers;
 - b. Signs with engineering grade sheeting;
 - c. Signs with dates after January 2014 or two years from the date of testing, whichever is lesser.
 - d. Overhead signs;
 - e. Overlaid Signs;
 - f. Damaged signs;
 - g. Adopt a Highway/Spot, WV Wildflowers, Wetland, Roadside Memorial, Watershed, Naturalized Area, and Project Marker signs;
4. A retro-reflectivity table shall be provided. The table shall report the average readings per color and comment on whether or not the sign meets the minimum MUTCD requirements based on the readings. The table shall also report the calculated contrast ratio for the white on red signs since the MUTCD requires it to be greater than 3:1. Also note the MUTCD specifies minimum retro-reflectivity levels for the background colors of specific warning signs that have a symbol inside of them.
5. Traffic Engineering will provide the minimum retro-reflectivity levels to be used to decide sign disposition, if different than stated in Table 2A-3 of the MUTCD.

2.0 SIGNING

2.1 General Signing

In general signs should be located so that they:

- A. Are outside the clear zone or shielded unless placed on a crash worthy support
- B. Optimize nighttime visibility
- C. Minimize the effects of mud splatter and debris
- D. Do not obscure each other
- E. Are not hidden from view
- F. Have adequate sight distance to allow for an appropriate response

2.2 Regulatory Sign Use and Location

Most Regulatory signs have a white background with black legend and border. STOP, YIELD, DO NOT ENTER, and WRONG WAY signs have a red background with white legend and border. The following is a list of the most commonly used Regulatory Signs and how they should be used. Regulatory signs other than those specified may be required. The MUTCD should be consulted for message, size and description of such signs. The sign design and standard number for permissible regulatory signs may be found in the Fabrication Manual. Some Regulatory Signs are typically dual installed for emphasis. There is a priority order for enhancing the visibility of Regulatory signing. This is covered in more detail in Section 2.3.2 Enhancing Visibility and Emphasis of Warning Signing.

2.2.1 Speed Limit (R2-1) Signs

- A. See Section 2.5.4.10 Post Interchange and Intersection Signs regarding R2-1 signs posted after an interchange or intersection. In rural areas with infrequent intersections or interchanges and a speed limit of 55 mph or more, the R2-1 sign should be installed at least every five miles. When a speed limit is reduced to 45 or 50 mph signs should be spaced at approximately one-mile intervals. At lower speed limits, such as 40 mph, signs should be spaced at one-half mile intervals. R2-1 signs shall be installed at each entrance to the state and at each county line and shall be supplemented with a RADAR ENFORCED (R2-8) sign. A RADAR ENFORCED (R2-8) sign shall also be installed underneath the first speed limit sign on roads entering municipalities. When used, the R2-8 sign shall always be mounted underneath the R2-1 sign and be the same width. Typically, R2-1 signs are 48 by 60 on freeways and expressways, 36 by 48 on other four lane highways, and 24 by 30 on two lane highways. Larger signs may be installed on two lane and other four lane highways where it is desired to emphasize the beginning of a reduced speed zone.
- B. When speed zones are necessary along the route, signs for these zones which include REDUCED SPEED LIMIT AHEAD WARNING sign (W3-5) and R2-1 signs, shall be erected in accordance with Figure 1. On freeways and expressways with speed limits of 65 mph or more, the W3-5 sign should be placed 1000 to 1500 feet in advance of the speed limit sign and shall be dual installed. The R2-1 sign shall also be dual

installed at speed reductions on Freeways and Expressways. On two lane roads with speed limits of 55 mph the W3-5 sign should be placed 300 to 500 feet in advance of the speed limit sign. Speed limit reductions are typically 10 mph or more. When a speed limit reduction is more than 15 mph a step-down speed limit should be provided. Speed limit signs should always be installed as close as possible to the location where the speed limit applies. This location is usually specified in a Commissioner's Order which is available from the Traffic Engineering Division. Where there is no Commissioner's Order establishing a speed limit, the statutory speed limit in West Virginia is 55 mph for open country highways on either multi-lane or two-lane highways.

- C. On steep downgrades speed limits are often reduced for heavy trucks. For these situations signs indicating TRUCK, REDUCED SPEED XX AHEAD (R2-5D), and VEHICLES OVER 26,000 GVWR may be installed. Then TRUCK, SPEED LIMIT XX, and OVER 26,000 GVWR are installed at regular intervals on the downgrade. See Section 2.3.5.6.

2.2.2 EMERGENCY STOPPING ONLY (R8-7)

R8-7 signs (48 by 36) are primarily used on freeways and expressways as discussed in Section 2.5.4.10.4. Smaller 30 by 24 signs may be used on two lane highways where a Commissioner's Order has been written to prohibit all but emergency stopping.

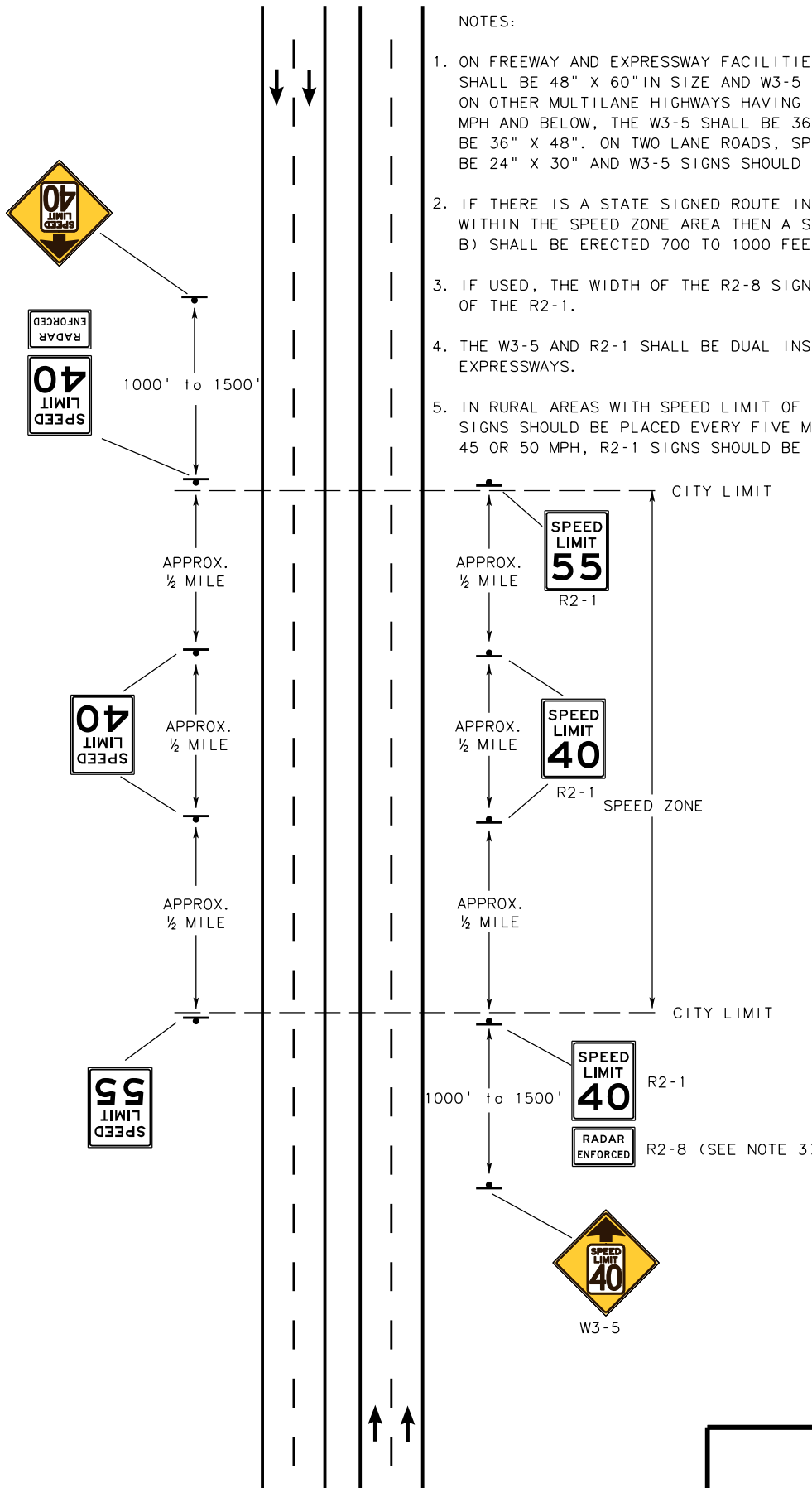

NOTES:

1. ON FREEWAY AND EXPRESSWAY FACILITIES, SPEED LIMIT SIGNS SHALL BE 48" X 60" IN SIZE AND W3-5 SIGNS SHALL BE 48" X 48". ON OTHER MULTILANE HIGHWAYS HAVING SPEED LIMITS 45 AND 50 MPH AND BELOW, THE W3-5 SHALL BE 36 X 36 AND THE R2-1 SHALL BE 36" X 48". ON TWO LANE ROADS, SPEED LIMIT SIGNS SHOULD BE 24" X 30" AND W3-5 SIGNS SHOULD BE 30" X 30".
2. IF THERE IS A STATE SIGNED ROUTE INTERSECTING THE EXPRESSWAY WITHIN THE SPEED ZONE AREA THEN A SPEED LIMIT SIGN (ASSEMBLY B) SHALL BE ERECTED 700 TO 1000 FEET BEYOND THE INTERSECTION.
3. IF USED, THE WIDTH OF THE R2-8 SIGN SHALL MATCH THE WIDTH OF THE R2-1.
4. THE W3-5 AND R2-1 SHALL BE DUAL INSTALLED ON FREEWAYS AND EXPRESSWAYS.
5. IN RURAL AREAS WITH SPEED LIMIT OF 55 MPH OR MORE, R2-1 SIGNS SHOULD BE PLACED EVERY FIVE MILES. FOR SPEED LIMITS OF 45 OR 50 MPH, R2-1 SIGNS SHOULD BE PLACED EVERY ONE MILE.

FIGURE 1
SIGNING FOR SPEED LIMITS AND SPEED ZONES

2.2.3 Authorized Vehicle Crossovers (R3-4 and R8-12 Signs)

Signing on freeways and expressways for Authorized Vehicle Crossovers shall consist of two NO U TURN signs (R3-4), one facing each direction of travel. These signs shall be located at each crossover used by the police, emergency, or maintenance vehicles. The sign size shall be 36 by 36. The R3-4 signs shall be supplemented by an additional sign panel indicating AUTHORIZED VEHICLES ONLY (R8-12). This sign assembly shall be mounted at a 45 degree angle to the roadway and shall be 36 by 36 in size and be back to back with the NO U TURN sign. Additionally, two separate 15 by 6 XR-3 Object markers shall be installed back to back at a 45 degree angle facing each direction of traffic. See Figure 2.

2.2.4 Signing for Truck Climbing Lanes (R4-6 and R4-3 Signs)

Signing for a truck climbing lane shall consist of a TRUCK LANE 500 FEET (R4-6) sign located 500 feet prior to the beginning of the taper for the truck climbing lane. On freeways and expressways a TRUCK LANE ½ MILE (D17-2) sign may be installed. The sign size shall be 48 by 60 for freeway and expressway facilities, 36 by 48 for four-lane highways with speed limits less than 55 mph, and should be 24 by 30 for two lane highways. The R4-6 sign should be followed by a SLOWER TRAFFIC KEEP RIGHT (R4-3) sign located 500 feet past the beginning of the truck climbing lane.

On truck climbing lanes the R4-3 sign shall be repeated at one-half mile intervals. All the signs shall be dual installed on divided highways. The R4-3 sign should also be used on four-lane sections where an up-grade of 3 percent or more exists for one-half mile or more and may be required at selected locations in the median where observation has determined a tendency for motorists to drive in the left lane below the normal speed of traffic. The R4-3 shall be 48 by 60 for freeway and expressway facilities, 36 by 48 for four-lane highways with speed limits less than 55 mph, and 24 by 30 for two lane highways. Often a truck climbing lane will also have signing prohibiting use of the left lane by trucks. See the following Section 2.2.5 and Figure 3.

2.2.5 Signing for LEFT LANE NO TRUCKS (R4-5A, R4-5B, and R4-5C Signs)

R4-5A signs shall be installed on freeways and expressways having three lanes in one direction at locations where a Commissioner's Order has been written to officially prohibit trucks from driving in the left lane. The signing is typically used along with signing for truck climbing lanes and shall consist of dual R4-5A ¼ or ½ MILE (W5-8A or W5-8B) installed ¼ or ½ mile prior to the beginning of the restriction, followed by BEGIN (R4-5B) and R4-5A signs dual installed at the point where the restriction begins. R4-5A signs should then be dual installed, if the median is sufficiently wide, at one-half mile intervals along the section. At the end of the restriction END (R4-5C) and R4-5A signs shall be dual installed. The R4-5A signs are 48 by 60, the R4-5B and R4-5C signs are 48 by 18, and the W5-8A or W5-8B signs are 48 by 18. When a sign is mounted on a concrete median barrier of a narrow median, the R4-5A sign size may be reduced to 36 by 48, and the R4-5B, R4-5C, W5-8A, and W5-8B signs may be reduced to 36 by 12. A typical sign layout is shown on Figure 3.

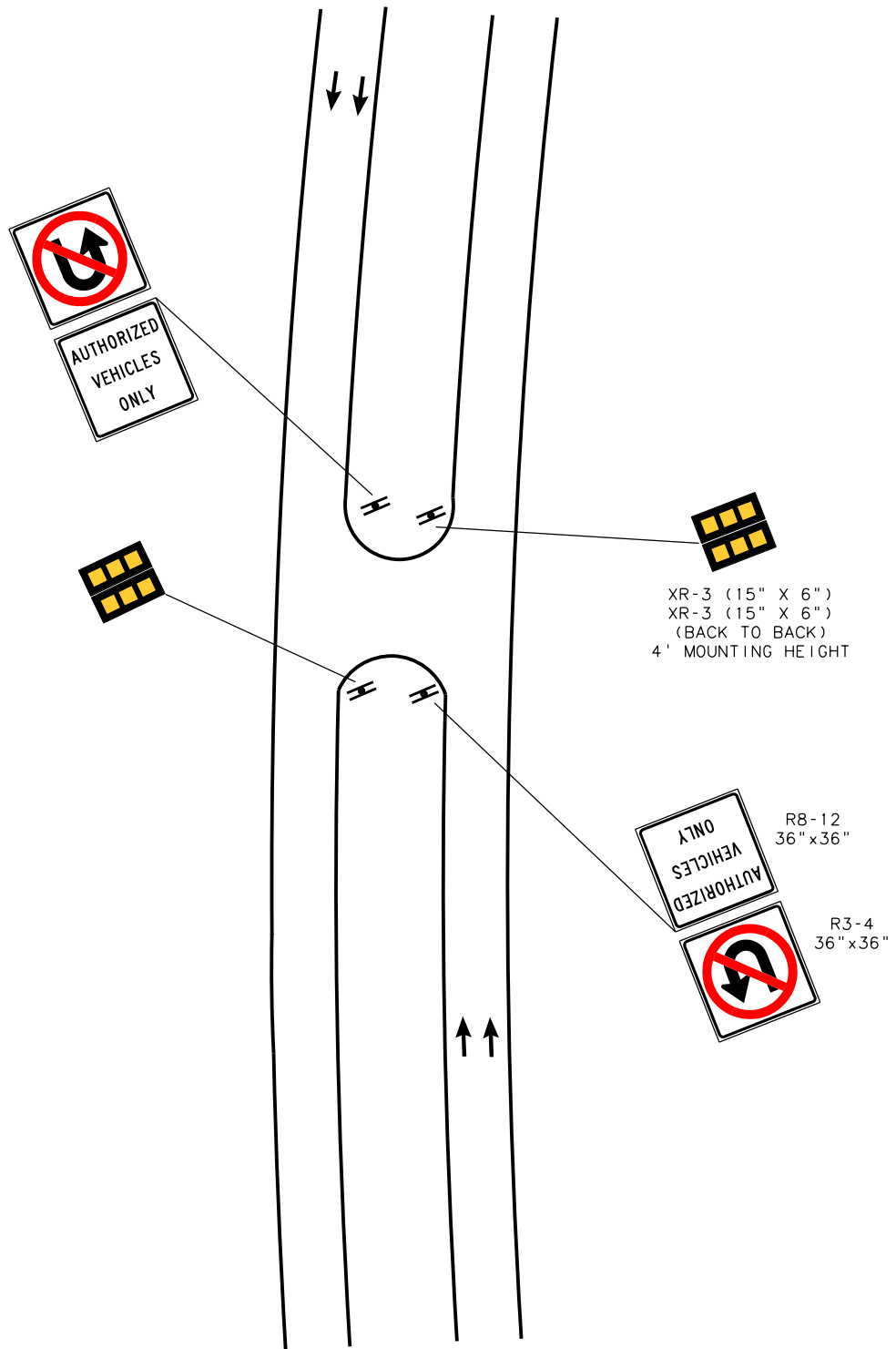

FIGURE 2

**AUTHORIZED VEHICLE
CROSSOVER SIGNING**

NOTES:

1. ON FREEWAYS AND EXPRESSWAYS, SIGN ASSEMBLIES A AND B SHALL BE 48" X 48", AND SIGN ASSEMBLIES C AND D SHALL BE 48" X 60".
2. ON ALL OTHER FOUR LANE HIGHWAYS HAVING SPEED LIMITS OF 55 MPH OR LESS, SIGN ASSEMBLIES A AND B SHALL BE 48" X 48" AND SIGN ASSEMBLIES C AND D SHALL BE 36" X 48". AFTER THE FIRST "SLOWER TRAFFIC KEEP RIGHT" SIGN IS ERECTED AT THE BEGINNING OF THE TRUCK CLIMBING LANE, THE SAME ASSEMBLIES C AND G SHALL BE ERECTED EVERY CONSECUTIVE 1/2 MILE. IF ANY ADDITIONAL R4-3 OR R4-5A SIGNS CANNOT MAINTAIN A MINIMUM DISTANCE OF 1/2 MILE FROM ASSEMBLY B, IT SHALL NOT BE ERECTED.
3. ASSEMBLIES A-1 AND B-1 SHALL BE ERECTED ON THE LEFT SIDE OF THE ROADWAY IF THE ROADWAY IS DIVIDED BY AT LEAST A 6 FT. MEDIAN. SMALLER SIZE SIGNS MAY BE INSTALLED ON THE MEDIAN BARRIER.
4. THIS TYPICAL LAYOUT IS NOT TO BE USED AT THE END OF AN ACCELERATION LANE.

5. SIGNS A AND B MAY BE REPLACED WITH ONE OVERHEAD SIGN "RIGHT LANE ENDS 1000 FT" FOR FREEWAYS OR EXPRESSWAYS HAVING AN ADT OF 30,000 OR MORE. IF INSTALLED, THE OVERHEAD SIGN MAY REMAIN UNLIGHTED.
6. SIGN LOCATIONS SHOULD BE ADJUSTED AS NEEDED BASED ON FIELD CONDITIONS AND OTHER SIGNING REQUIRED.
7. ON FREEWAYS AND EXPRESSWAYS, NEXT TRUCK LANE 2 MILES (D17-1) AND TRUCK LANE 1/2 MILE (D17-2) MAY BE INSTALLED.

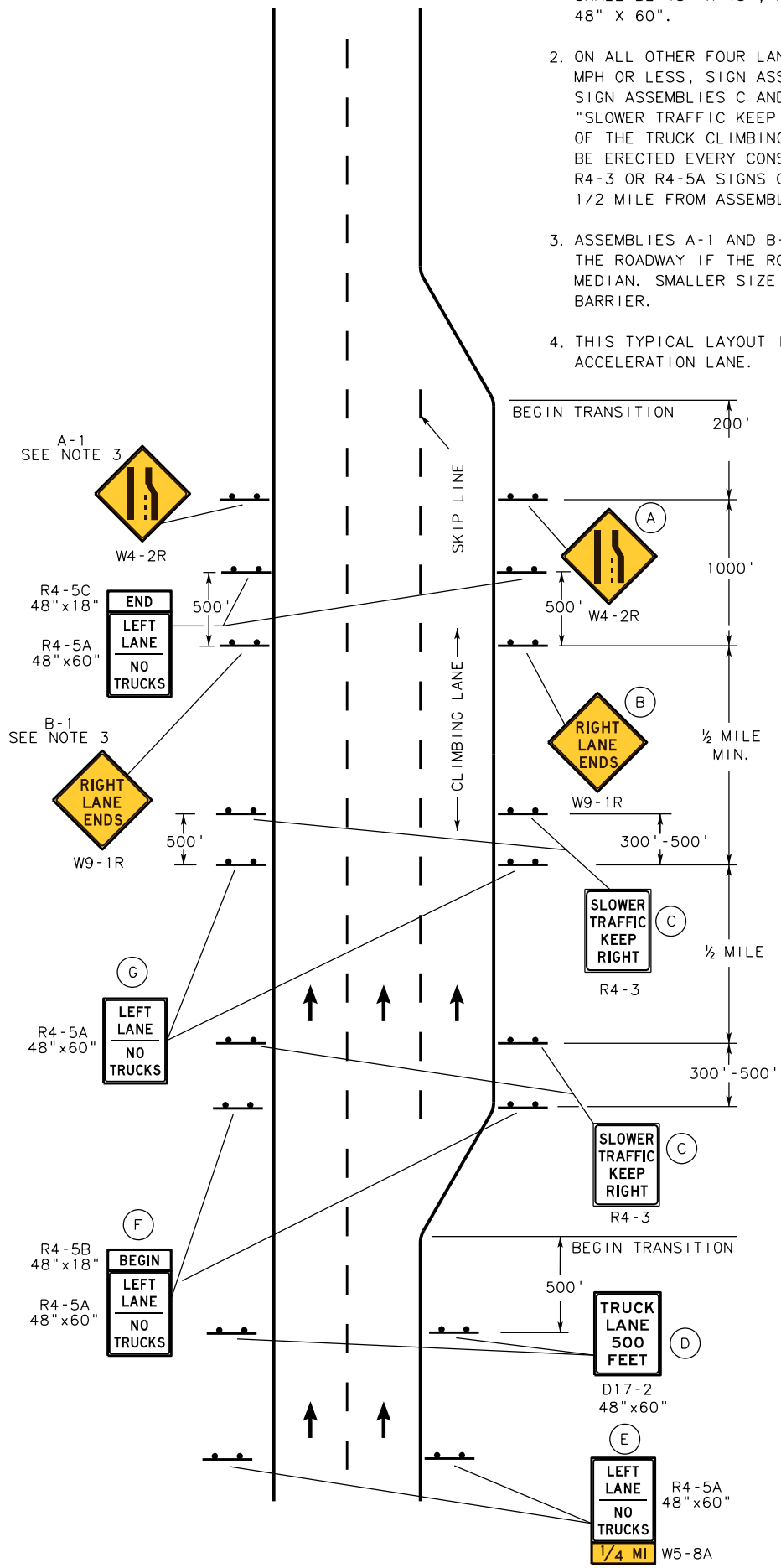

FIGURE 3
SIGNING FOR
TRUCK CLIMBING LANE

2.2.6 Regulatory Signing for Expressway Intersections and Ramp Terminals (R1-1, R1-2, R4-7, R4-8, R5-1, R5-1A, R5-4, R6-1, R6-3 Signs)

Regulatory signs for expressway intersections include STOP (R1-1), YIELD (R1-2), KEEP RIGHT (R4-7), KEEP LEFT (R4-8), DO NOT ENTER (R5-1), WRONG WAY (R5-1A), ONE WAY (R6-1), DIVIDED HIGHWAY (R6-3), and YIELD (R1-2) signs. See Figures 4, 5, 6, 27, 28 and 29 for sample layouts of regulatory signing at expressway intersections. See Figure 7 for sample layouts of regulatory signing on freeway and expressway entrance and exit ramps. Red reflective post strips shall be used with all R1-1, R1-2, R5-1, and R5-1A signs at all expressway intersections. White reflective post strips shall be used with all R4-7, R4-8, and R6-1 signs.

2.2.6.1 R1-1, R1-4, R1-12/R1-10P, R3-2R, R6-3, R6-3A

A 36 by 36 R1-1 sign shall be erected at ramp terminals and at crossroads entering an expressway unless there is a traffic signal or a yield condition. A DIVIDED HIGHWAY sign (R6-3 or R6-3A) shall be installed underneath each R1-1 sign on the side road approach to an expressway, and its size shall be 24 by 18. R1-1 signs on two lane roadways on approaches to other two lane roadways should be 30 by 30. Where side roads intersect a multi-lane street or highway that has a speed limit of 45 mph or higher the minimum size of the R1-1 shall be 36 by 36. R1-1 signs may be supplemented with EXCEPT WHEN TURNING RIGHT (R1-12) or EXCEPT RIGHT TURN (R1-10P) at locations where there is no conflicting traffic. R1-1 signs at intersections where all approaches stop shall be supplemented with ALL WAY (R1-4) plaques mounted underneath the R1-1 signs. RIGHT TURN ONLY (R3-2R) should be installed underneath the STOP sign on the approach to a divided roadway with no median opening for left turns. See Figures 4, 5, 6, and 7.

2.2.6.2 Yield (R1-2) and TO ONCOMING TRAFFIC (R1-13)

If traffic turning right at an intersection of an expressway is separated by a right-turn channelization island, consideration should be given to the use of a 48 by 48 R1-2 sign to control this right-turn traffic. R1-2 signs on the right turn channelized approach to a two lane roadway or low speed city streets shall be 36 by 36. An R1-2 sign shall not be installed to control a motorist making a left turn or going straight through at an intersection. The sign shall be erected on the right near the location where the driver would have to hesitate in order to determine whether to enter the traffic stream. The sign should always be installed within 50 feet of the edge of pavement of the intersecting roadway. If there is an adequate acceleration lane for traffic turning right onto a roadway as determined by acceleration geometry and/or sight distance, neither a R1-2 nor a R1-1 sign should be installed. On two lane roadways approaching one lane sections, a R1-2 sign may be used along with a TO ONCOMING TRAFFIC (R1-13) mounted underneath. The R1-13 shall be 24 by 24 on a bike path and 30 by 30 for locations facing traffic flow.

SIGN NO.	SIZE
R1-1	36" x 36"
R4-7	24" x 30"
XR-3	15" x 6"
R5-1A	36" x 24"
R5-1	36" x 36"
R6-1L	48" x 18"
R6-3	24" x 18"
R6-3A	24" x 18"

NOTES:

1. THIS IS A TYPICAL SIGNING LAYOUT FOR AT-GRADE INTERSECTION ON AN EXPRESSWAY.
2. INSTALL R4-7 AND R5-1 IN MEDIAN AT 45° ANGLE.
3. R5-1 SHALL BE INSTALLED 50 FEET PAST RADIUS RETURN.
4. R5-1A SHALL BE INSTALLED 200 FEET MINIMUM AND 500 FEET MAXIMUM BEYOND R5-1.
5. ALL ASSEMBLIES SHALL HAVE REFLECTIVE SIGN SUPPORT STRIPS.
6. PUT R5-1A ON SEPARATE POST FROM GUIDE SIGN IF DISTANCE TO GUIDE SIGN EXCEEDS 500 FEET.

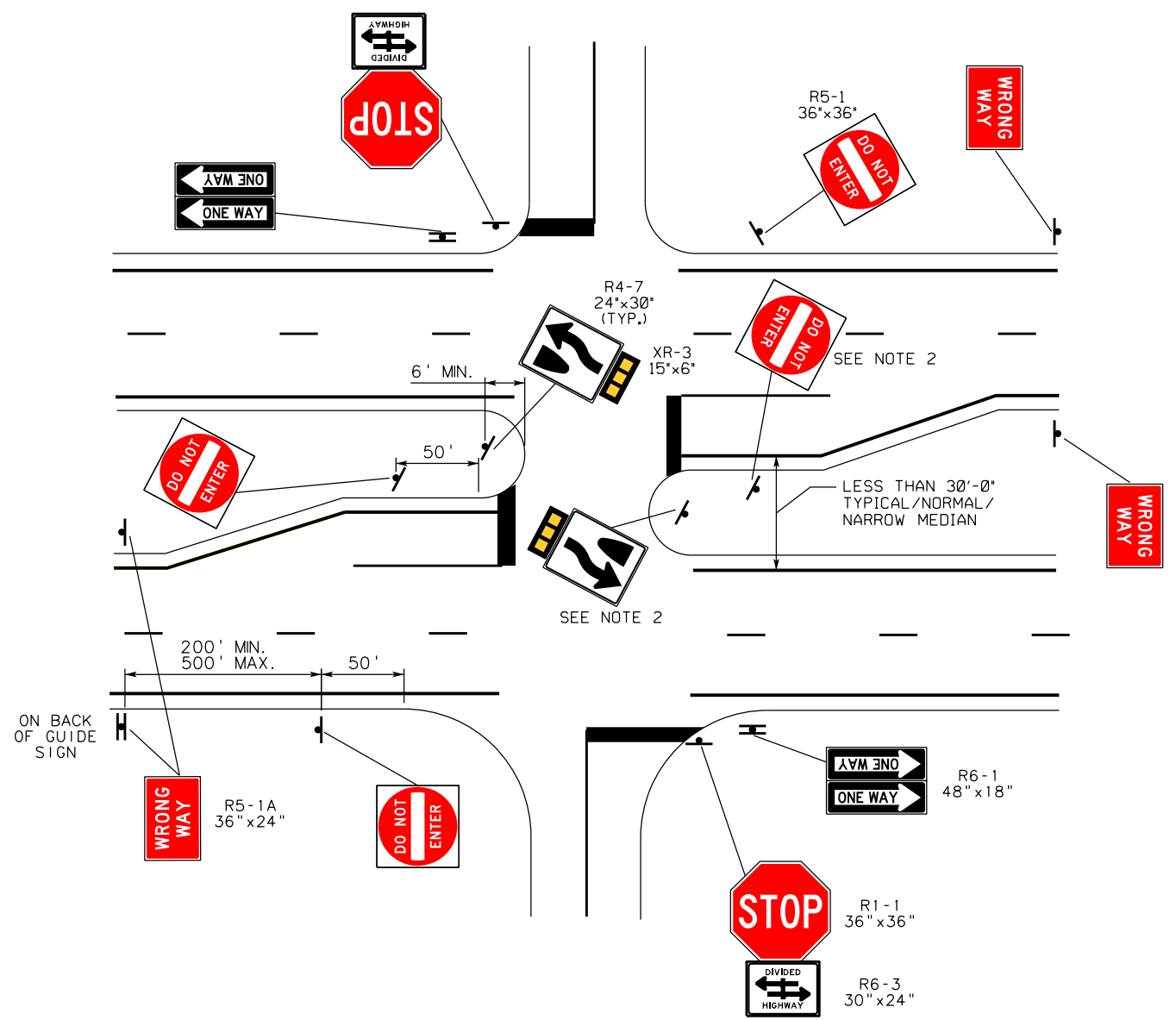

FIGURE 4
REGULATORY SIGNING
AT CROSSROAD
MEDIANS LESS THAN 30 FEET

NOTES:

1. THIS IS A TYPICAL SIGNING LAYOUT FOR AT-GRADE INTERSECTION ON AN EXPRESSWAY.
2. INSTALL R4-7 AND R5-1 IN MEDIAN AT 45° ANGLE.
3. R5-1 SHALL BE INSTALLED 50 FEET PAST RADIUS RETURN.
4. R5-1A SHALL BE INSTALLED 200 FEET MINIMUM AND 500 FEET MAXIMUM BEYOND R5-1.
5. ALL ASSEMBLIES SHALL HAVE REFLECTIVE SIGN SUPPORT STRIPS.
6. PUT R5-1A ON SEPARATE POST FROM GUIDE SIGN IF DISTANCE TO GUIDE SIGN EXCEEDS 500 FEET.

SIGN NO.	SIZE
R1-1	36" x 36"
R4-7	24" x 30"
XR-3	15" x 6"
R5-1A	36" x 24"
R5-1	36" x 36"
R6-1L	48" x 18"
R6-3A	24" x 18"

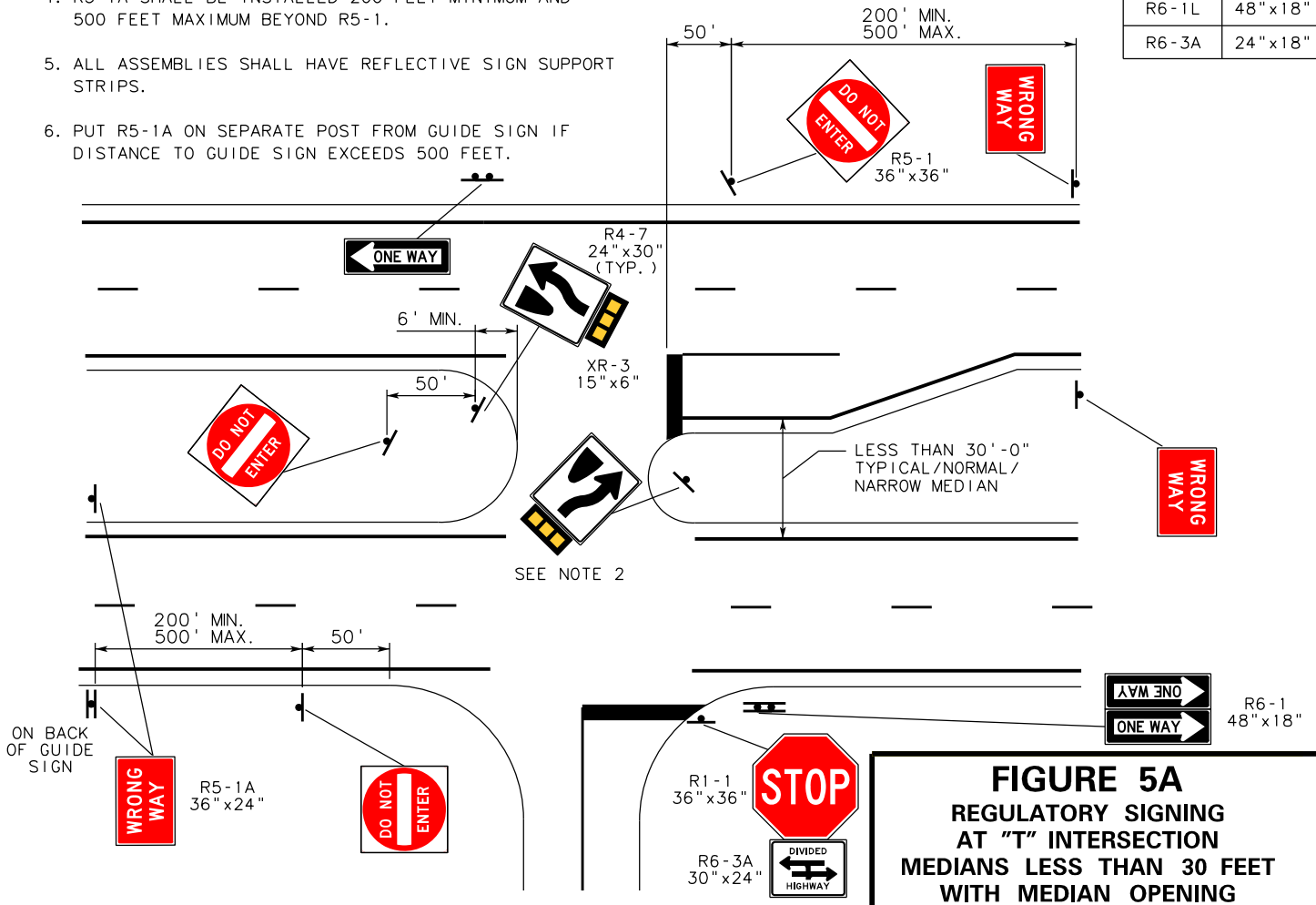
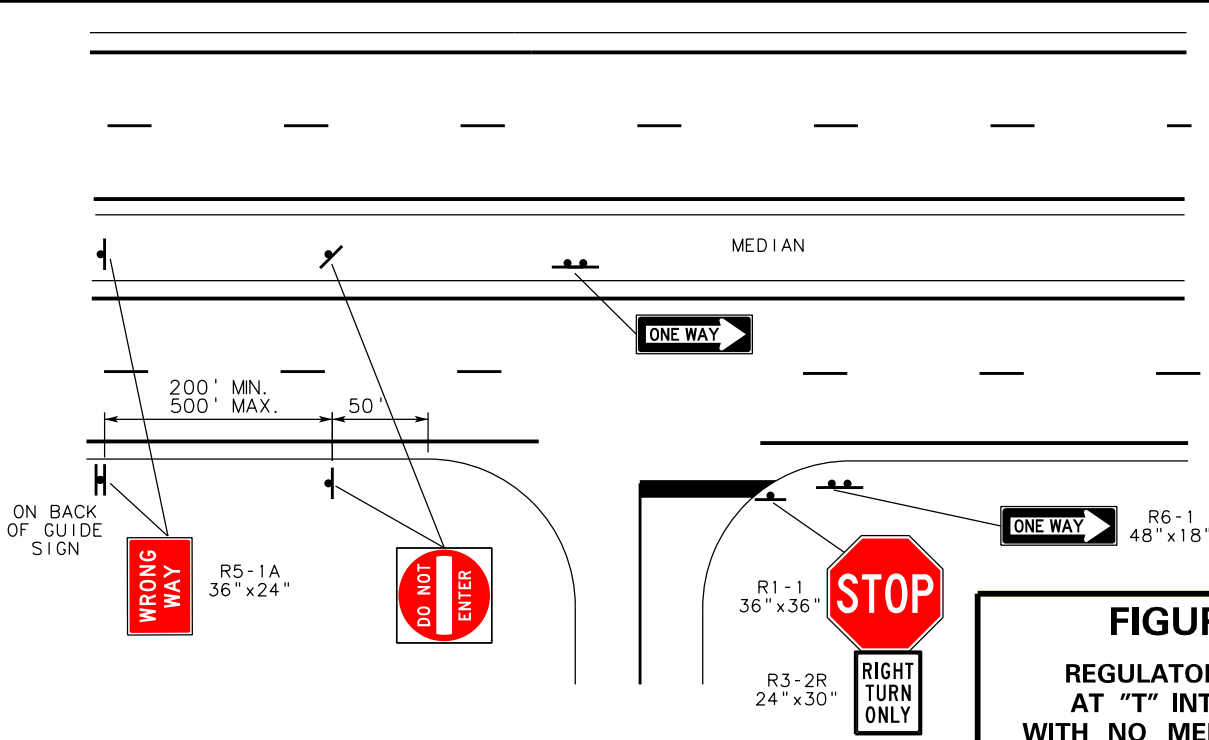

FIGURE 5A
REGULATORY SIGNING AT "T" INTERSECTION
MEDIANS LESS THAN 30 FEET
WITH MEDIAN OPENING



SIGN NO.	SIZE
R1-1	36" x 36"
R4-7	24" x 30"
XR-3	15" x 6"
R3-2R	24" x 30"
R5-1A	36" x 24"
R5-1	36" x 36"
R6-1L	48" x 18"

FIGURE 5B
REGULATORY SIGNING AT "T" INTERSECTION
WITH NO MEDIAN OPENING

FIGURE 6A

REGULATORY SIGNING AT "T" INTERSECTION MEDIANS GREATER THAN 30 FEET

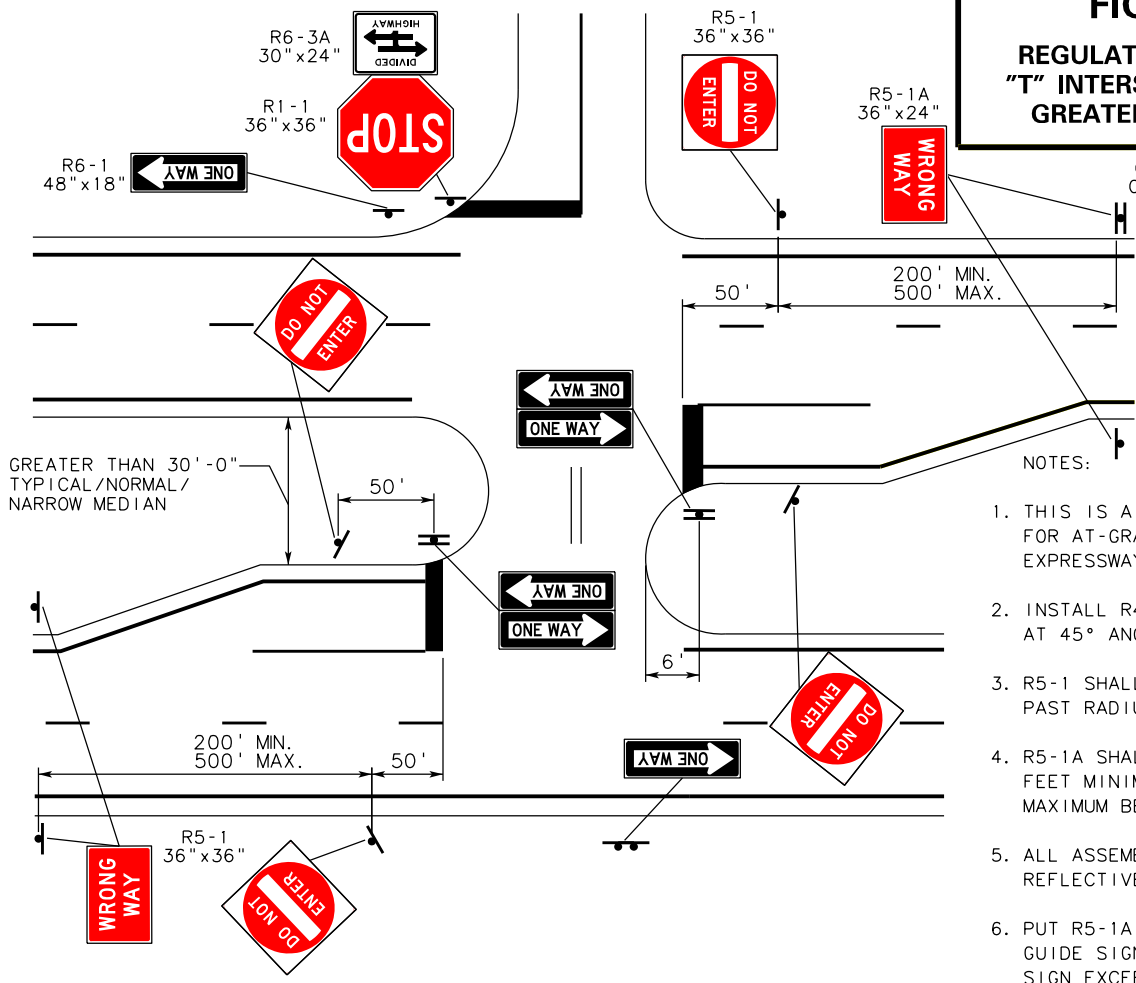

SIGN NO.	SIZE
R1-1	36" x 36"
R5-1A	36" x 24"
R5-1	36" x 36"
R6-1L	48" x 18"
R6-3A	24" x 18"

- NOTES:
1. THIS IS A TYPICAL SIGNING LAYOUT FOR AT-GRADE INTERSECTION ON AN EXPRESSWAY.
 2. INSTALL R4-7 AND R5-1 IN MEDIAN AT 45° ANGLE.
 3. R5-1 SHALL BE INSTALLED 50 FEET PAST RADIUS RETURN.
 4. R5-1A SHALL BE INSTALLED 200 FEET MINIMUM AND 500 FEET MAXIMUM BEYOND R5-1.
 5. ALL ASSEMBLIES SHALL HAVE REFLECTIVE SIGN SUPPORT STRIPS.
 6. PUT R5-1A ON SEPARATE POST FROM GUIDE SIGN IF DISTANCE TO GUIDE SIGN EXCEEDS 500 FEET.

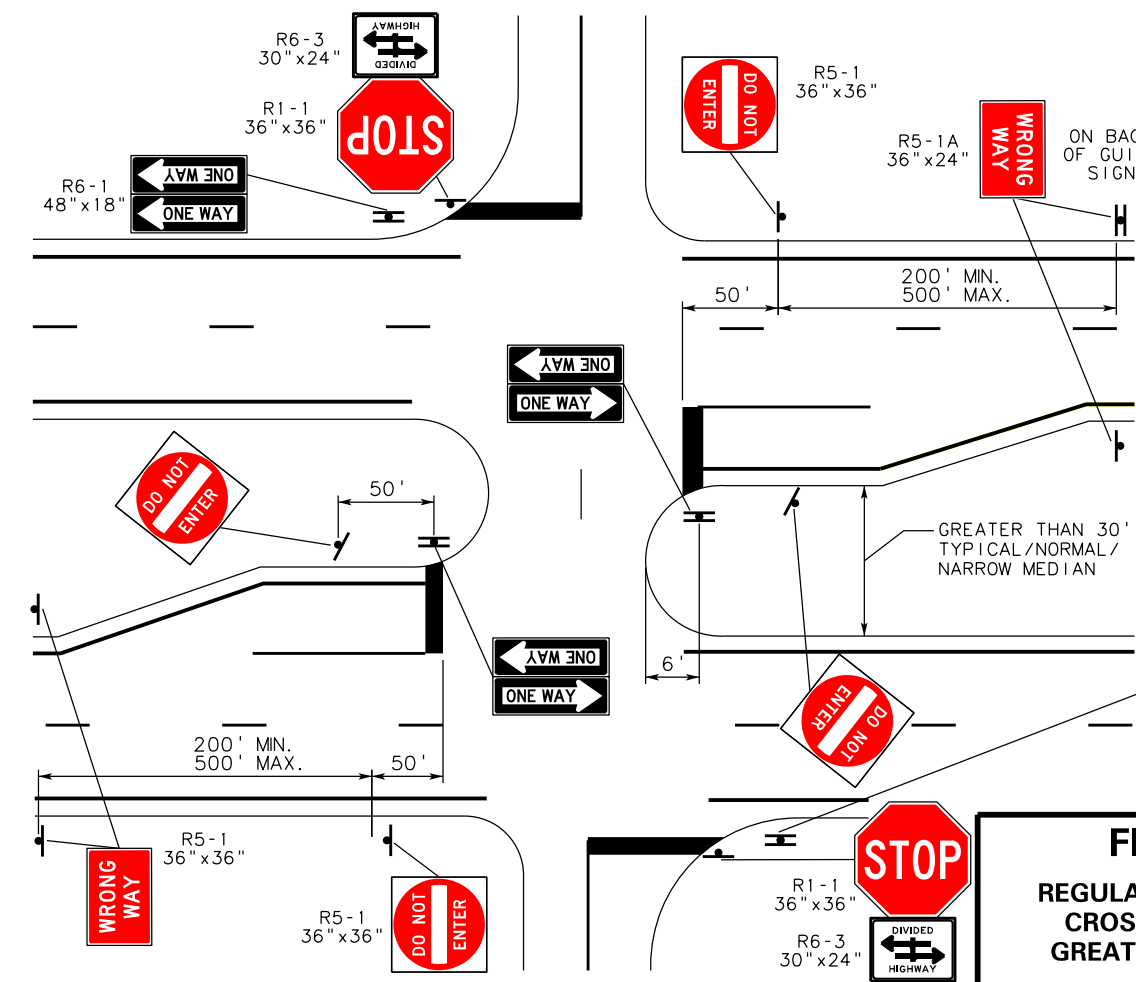

SIGN NO.	SIZE
R1-1	36" x 36"
R5-1A	36" x 24"
R5-1	36" x 36"
R6-1L	48" x 18"
R6-3	24" x 18"

FIGURE 6B

REGULATORY SIGNING AT CROSSROAD MEDIANS GREATER THAN 30 FEET

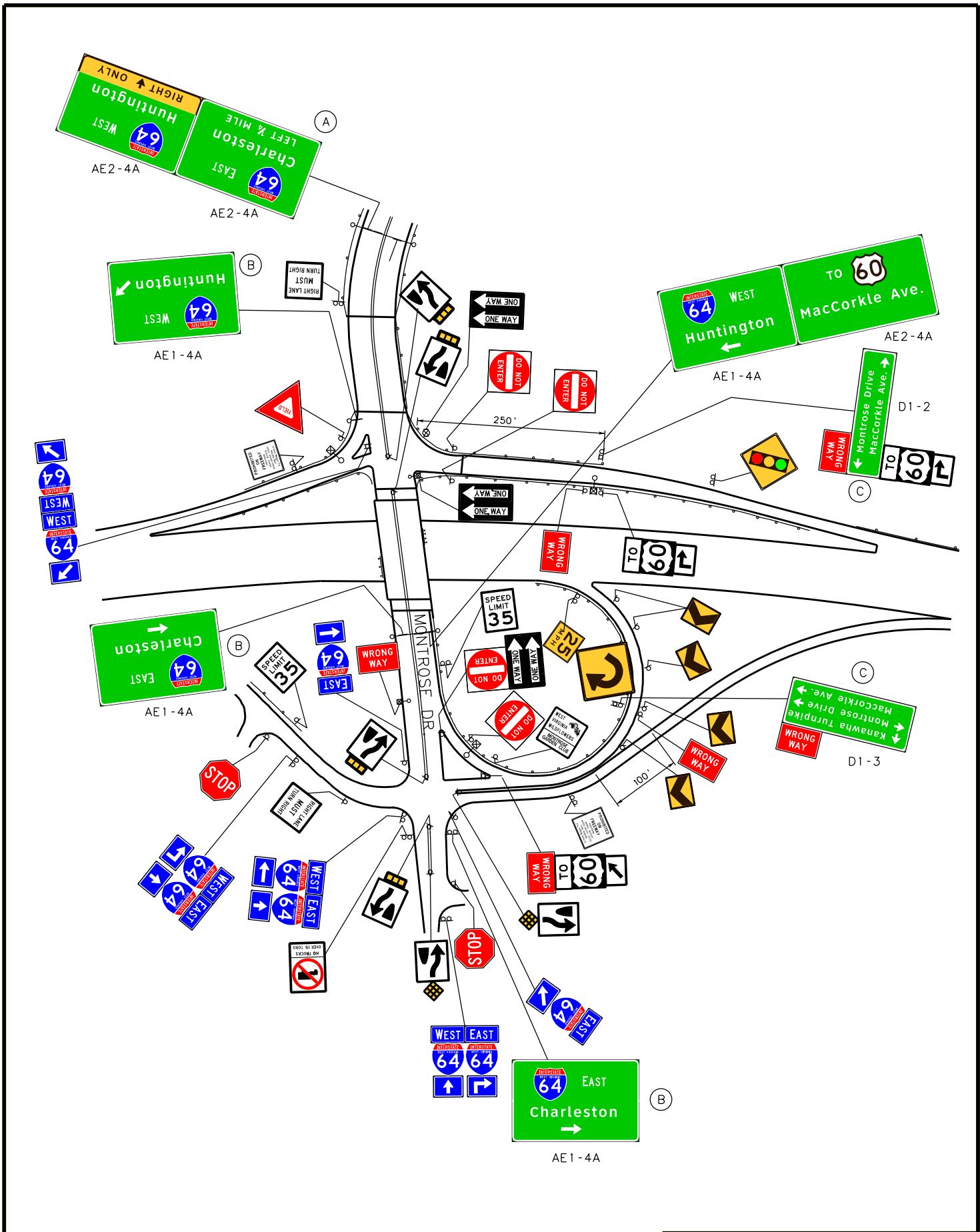

SIGN	TITLE	DISTANCE FROM RAMP
A	ADVANCE ENTRANCE SIGN	500' TO 700'
B	RAMP ENTRANCE DIRECTION	0' TO 50'
C	RAMP DIRECTIONAL	200' TO 700'

FIGURE 7
REGULATORY & WARNING
SIGNING WITHIN A
MAJOR OR INTERMEDIATE
INTERCHANGE

2.2.6.3 Keep Right (R4-7)

A R4-7 sign shall be erected at the ends of medians where traffic is required to pass to the right of a roadway feature or obstruction. Where a median begins on an expressway, a 36 by 48 R4-7 sign shall be erected as close as practical to the approach end of the raised median and perpendicular to approaching traffic. For medians too narrow for a 36 by 48 sign, the size may be reduced to 24 by 30. An 18 by 18 XR-9 OBJECT MARKER shall be installed underneath the R4-7 or R4-8. At internal intersections where there are medians, a 24 by 30 R4-7 sign shall be erected at a 45 degree angle to face traffic turning left from a side road to direct them to go to the right of the median. A 15 by 6 XR-3 OBJECT MARKER shall be installed underneath the R4-7. XR-3 OBJECT MARKER should be erected at the first end of any median or channelization island even though it may not have a R4-7 sign. For an at grade intersection on a roadway having a narrow median, XR-3 should be installed at each end of the median. See Figures 4, 5, 6, and 16.

2.2.6.4 One Way (R6-1), Wrong Way (R5-1A) and Do Not Enter (R5-1)

These signs should be erected at ramp terminals and at intersections in accordance with Figures 4, 5, 6, 7, 22, 27, 28, 29, and 30. At intersections along expressways the R6-1L installed on the far left of the intersection shall be 48 by 18, the R5-1A shall be 36 by 24 and the R5-1 shall be 36 by 36. At intersections on expressways with wide medians R6-1L and R6-1R shall be mounted back to back on the right side of traffic approaching from the side street and on the right side of the median where the left turn from the expressway intersects the second crossroad of the divided highway. The R6-1 shall not be mounted with the STOP (R1-1), NO RIGHT TURN (R3-1) or the NO LEFT TURN (R3-2) signs. At ramp terminals the R6-1L and R6-1R shall be 36 by 12, the R5-1A shall be 42 by 30 and the R5-1 shall be 48 by 48. R6-2 is used for urban, signalized intersections.

2.2.7 Two-Way Left Turn Only Lane Signing (R3-9B, R3-9C, and R3-9E)

Two-Way Left Turn Only signing shall be installed on local roads and streets for every two-way left turn lane. This signing should not be used on expressways. A BEGIN CENTER LANE LEFT TURN ONLY sign (R3-9C) shall be installed as close as possible to each actual beginning of the lane. An END CENTER LANE LEFT TURN ONLY sign (R3-9E) shall be installed as close as possible to each end of the designated lane. CENTER LANE LEFT TURN ONLY signs (R3-9B) should be installed at 1000 to 1200 feet (maximum 1500 feet) intervals in both directions. When the roadway is only three lanes total, the R3-9B signs should be 24 by 36 and should be ground-mounted on the right side of the roadway. The R3-9C and R3-9E signs shall be 24 by 48. For roadways of five lanes or more the R3-9B signs shall be 36 by 48 and be installed overhead with signs mounted back to back on generally single arm cantilever overhead structures spaced at 1000 to 1500 feet. The R3-9C and R3-9E signs on roadways of five lanes or more shall be 36 by 60. The overhead structures shall not block sidewalks. Extruded sizes (60 by 72 and 60 by 84) should be used if there are existing box truss structures on which the signs can be installed. See Figures 8 and 9.

NOTES

1. R3-9B SIGNS SHOULD BE SPACED AT 800' - 1000' FOR 3 LANES.

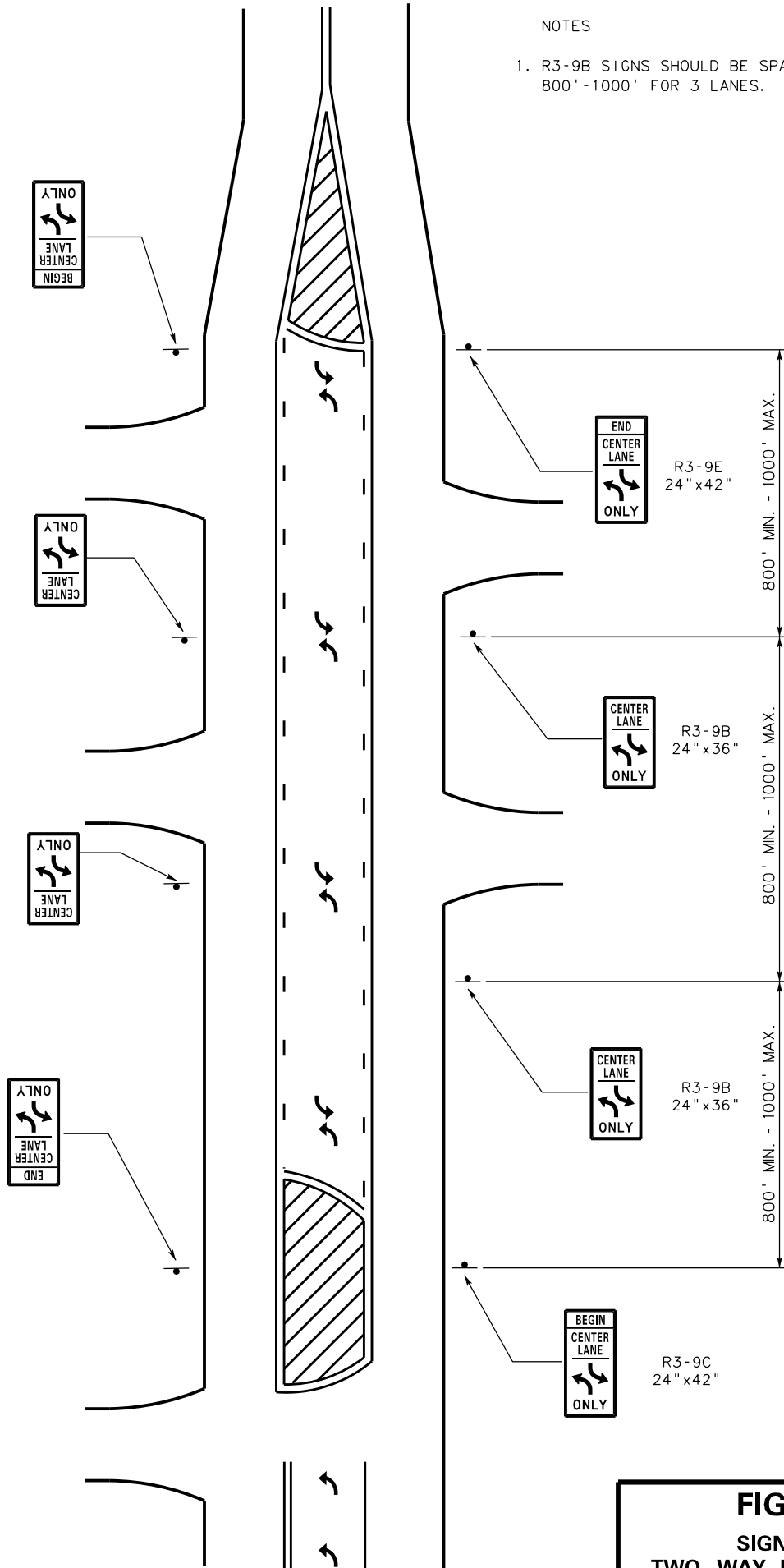

FIGURE 8
SIGNING FOR
TWO WAY LEFT TURN LANE
ON THREE LANE HIGHWAY

NOTES:

1. FOR 5 OR MORE LANES, ALL SIGNS SHOULD BE INSTALLED ON OVERHEAD CANTILEVER STRUCTURES BACK TO BACK. R3-9B SHOULD BE 36"x48" AND R3-9C & R3-9E SHOULD BE 36"x60".
2. R3-9B SIGNS SHOULD BE SPACED AT 1200' FOR 5 OR MORE LANES. MAXIMUM SPACING SHALL BE 1500'.

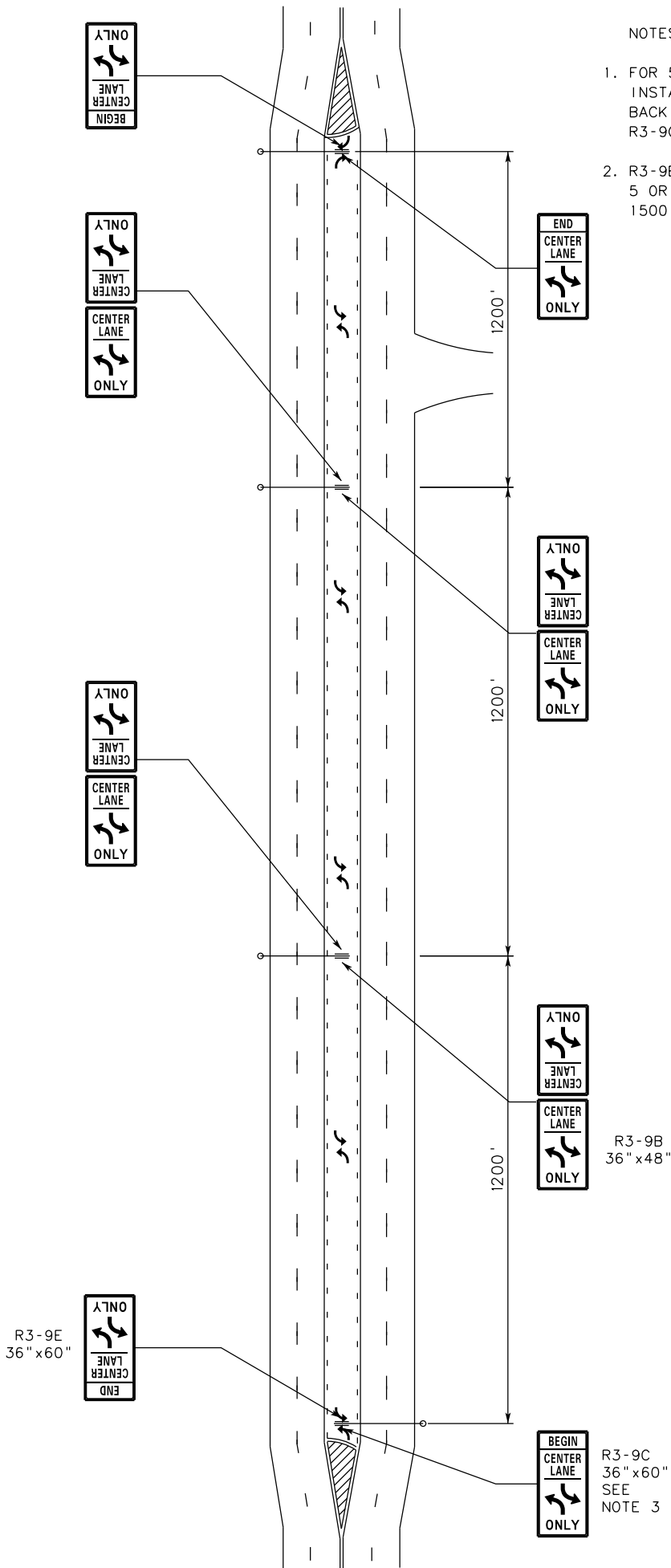
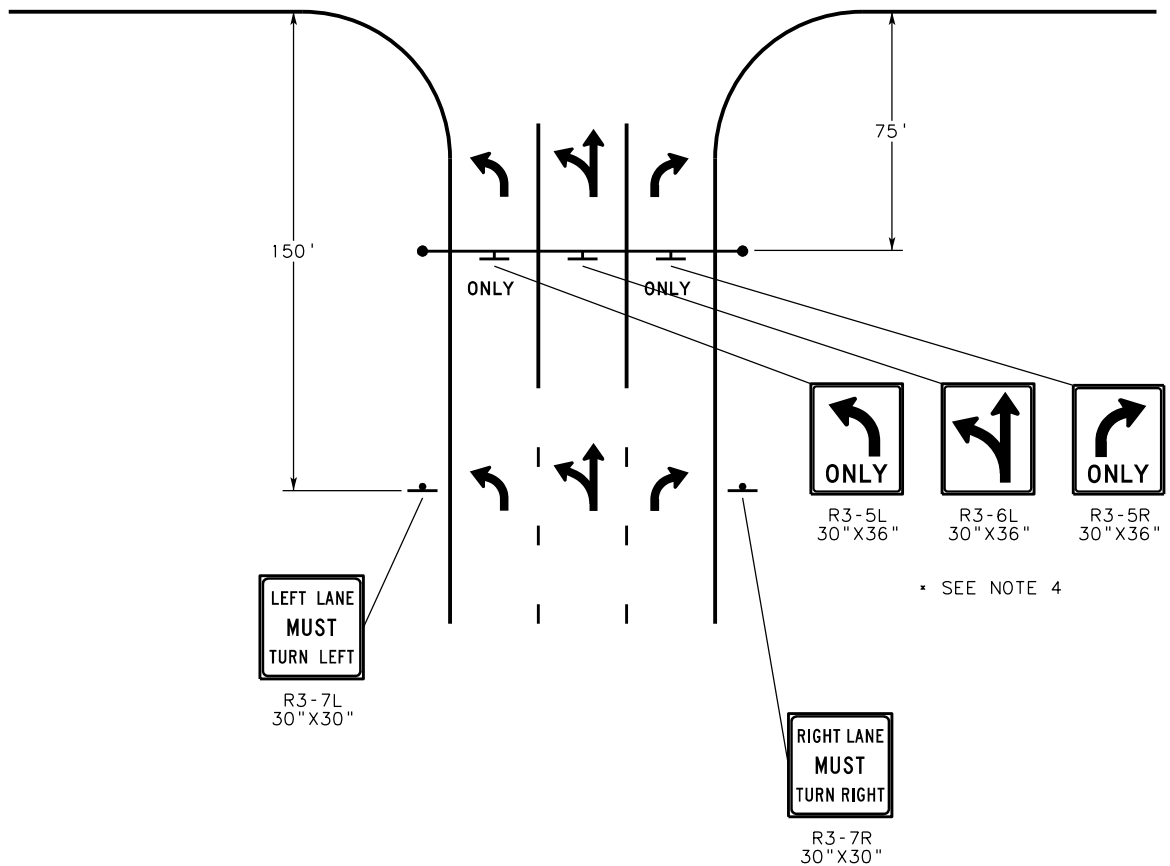

FIGURE 9
SIGNING FOR
TWO WAY LEFT TURN LANE
ON FIVE LANE HIGHWAY



NOTES:

1. THE OVERHEAD SIGN ASSEMBLY SHALL BE LOCATED SO THAT IT DOES NOT RESTRICT SIGHT DISTANCE TO THE TRAFFIC SIGNAL. IF OVERHEAD SIGN CANNOT BE INSTALLED AT THIS LOCATION WITHOUT BLOCKING VIEW OF THE TRAFFIC SIGNAL GROUND MOUNTED SIGNS SHALL BE INSTALLED.
2. SIZE OF SIGNS MAY BE INCREASED FOR INSTALLATION ON RAMPS OR ON HIGH SPEED APPROACHES.
3. LOCATIONS OF SIGNS MAY BE MOVED FURTHER FROM THE INTERSECTION FOR HIGH SPEED APPROACHES.
4. THIS IS ONLY ONE POSSIBLE ALTERNATIVE FOR SIGNING THE CENTER LANE. OTHER POSSIBLE SIGNS INCLUDE:
R3-5A, R3-6R, R3-6C OR R3-6D.
5. THE OVERHEAD SIGNS SHALL MATCH THE LANE CONFIGURATION OF THE PAVEMENT PARKINGS.
6. IF IT IS NOT POSSIBLE TO INSTALL A SIGN ON THE LEFT HAND SIDE AT THE UPSTREAM LOCATION AND AT THE DOWNSTREAM LOCATION (AND NO OVERHEAD STRUCTURE IS IN PLACE OR INSTALLED), INSTALL APPROPRIATE R3-8 SIGNS ON THE RIGHT HAND SIDE.

FIGURE 10A
TURN RESTRICTION AND
LANE CONTROL SIGNS FOR
THREE LANE APPROACHES

NOTES

1. SPACING TO THE LEFT LANE STOP LINE SHALL BE 100' FOR SPEED LIMITS LESS THAN OR EQUAL TO 40 AND 225' FOR SPEED LIMITS GREATER THAN 40.
2. SPACING TO THE LEFT LANE STOP LINE SHALL BE 625' FOR SPEED LIMITS LESS THAN OR EQUAL TO 40 AND 825' FOR SPEED LIMITS GREATER THAN 40.
3. FOR SPEED LIMITS GREATER THAN 40, SIGNS R4-15 AND R4-16 SHALL BE 36"x42".
4. DISTANCE SHOWN ON SUPPLEMENTAL PLAQUE IS DEPENDENT ON SIGHT DISTANCE.

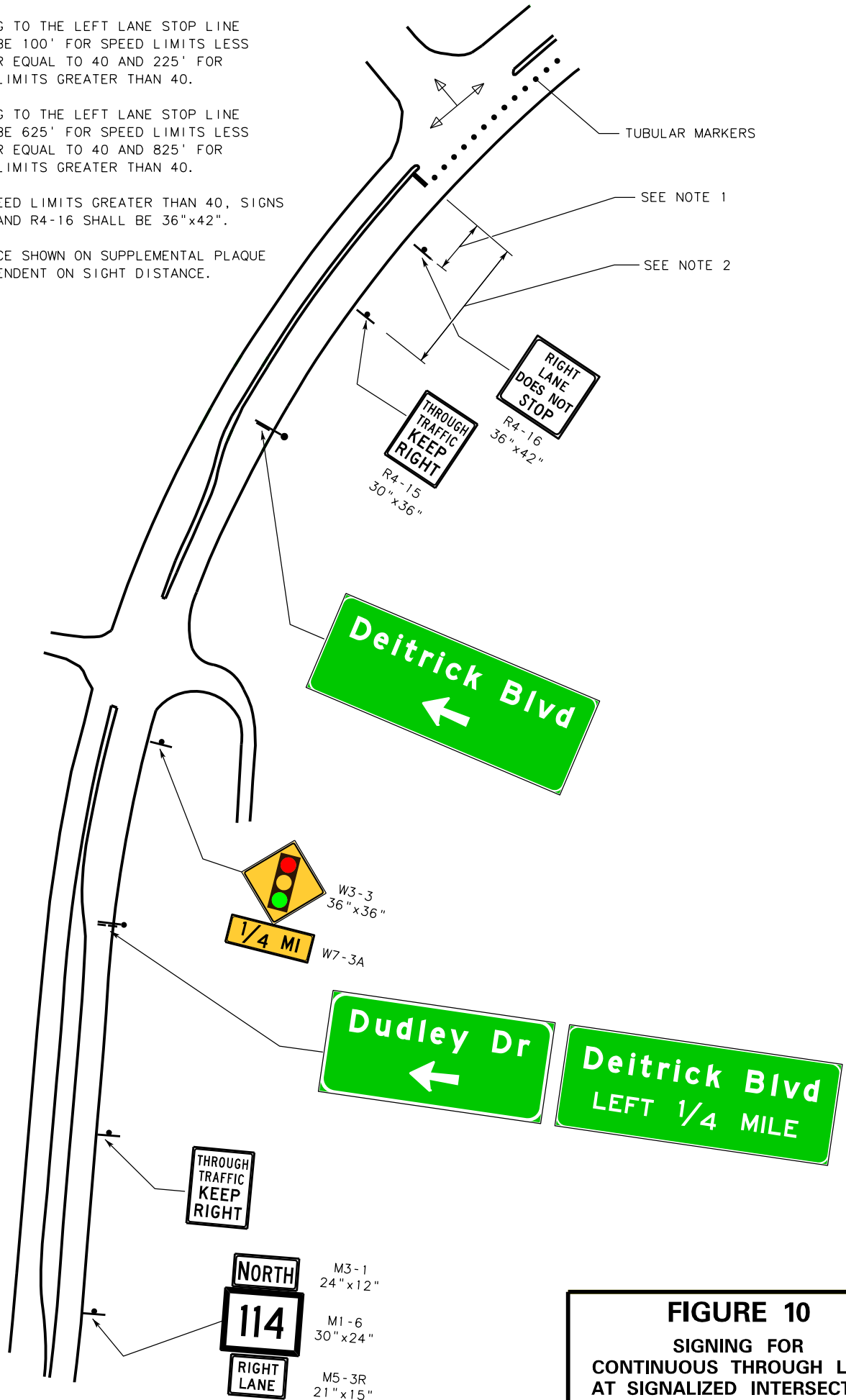

FIGURE 10
SIGNING FOR
CONTINUOUS THROUGH LANE
AT SIGNALIZED INTERSECTION

2.2.8 Lane Control Signing (R3-5, R3-5A, etc.)

Lane control signing, if used, shall require road users in certain lanes to turn, shall designate the turns which are allowed in certain lanes, or shall indicate prohibited or permitted movements from a lane. R3-5 or R3-5A signs (30 by 36 is the standard size) should preferably be mounted overhead directly over the lane to which it applies. Other intersection lane control signing such as R3-6, R3-6C, R3-6D, R3-8, R3-8A, R3-8B, R3-8C, and R3-8D may be used to designate mandatory or optional movements from lanes at intersections. See Figure 10A.

2.2.9 Roundabout Signing (R6-4A, R6-4B, R1-2 and R3-8)

A YIELD (R1-2) sign shall be installed on the right side of each approach to a roundabout. If the center island is large enough for signing, ROUNDABOUT DIRECTIONAL ARROW signs (R6-4A or R6-4B) should be installed in the island at a mounting height of four feet to direct traffic to turn counter-clockwise around the island. FISH HOOK LANE CONTROL signs (R3-8) shall be installed on the approach to roundabouts to indicate the left turn around the center island. See Figure 11A for a single lane roundabout and Figure 11B for a multi-lane roundabout. Also, refer to section 2B.43 of the MUTCD.

2.2.10 Exclusion Signing (R5-5F, R5-5P, R5-5R, and R8-11A)

A PROHIBITED ON FREEWAY (R5-5F) sign (42 by 42) prohibits pedestrians, animals, bicycles, motor-driven cycles, farm tractors, and all-terrain vehicles on a freeway. It shall be installed on the right side of all freeway entrance ramps approximately 200 feet from the crossroad intersection. The sign should also be installed on the right side of entrance ramps to sections of expressways having only interchanges. A PROHIBITED IN REST AREA (R5-5R, 42 by 36), PROHIBITED IN PARK AND RIDE (R5-5P, 42 by 36), and NO OVERNIGHT PARKING (R8-11A, 24 by 24) signs may be installed in rest areas or park and ride facilities as appropriate. See Figures 35 and 41.

2.2.11 Turn Restriction Signing (R1-12, R3-1, R3-2, R3-3, R3-4, R3-7L, R3-7R)

NO U TURNS (R3-4) signs (24 by 24) should be installed on divided highways at Authorized Vehicle Crossovers and at other locations where motorists should be prohibited from making a U-turn. The sign should be installed only after a traffic engineering study determines the need for the sign. See Figure 2. NO RIGHT/LEFT TURN (R3-1 or R3-2) signs (24 by 24) may be installed where either turns are prohibited by a Commissioner's Order or where wrong-way turns would be made onto a one way street or roadway. NO TURNS (R3-3) signs (24 by 24) should be installed where all turns are prohibited. Mandatory movement LEFT LANE MUST TURN LEFT (R3-7L) and RIGHT LANE MUST TURN RIGHT (R3-7R) signs (30 by 30) should be installed where motorists in the respective lane are required to turn. EXCEPT WHEN TURNING RIGHT (R1-12) signs (24 by 30) or EXCEPT RIGHT TURN (R1-10P) signs 24 by 18 should be installed underneath R1-1 signs where the motorist on the approach is not required to stop. See Figure 11A for an example of turn restriction signs

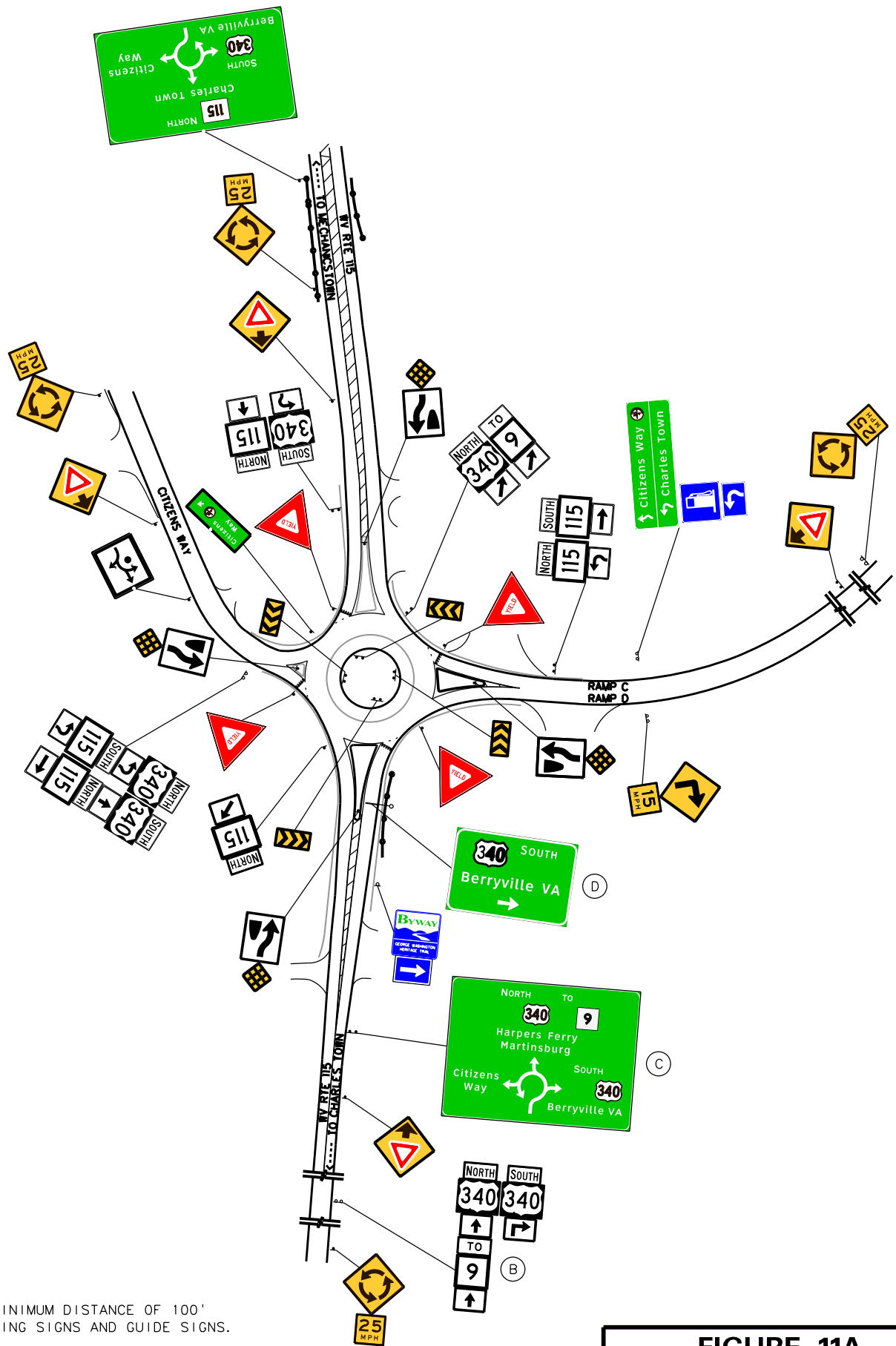

NOTE

MAINTAIN A MINIMUM DISTANCE OF 100'
BETWEEN WARNING SIGNS AND GUIDE SIGNS.

SIGN	TITLE	DISTANCE FROM CROSSROAD INTERSECTION
B	ADVANCE ROUTE TURN ASSEMBLY	400' to 600'
C	DESTINATION SIGN	400' to 600'
D	DIRECTIONAL ASSEMBLY	0' to 100'

FIGURE 11A
SIGNING FOR SINGLE LANE ROUNDABOUT

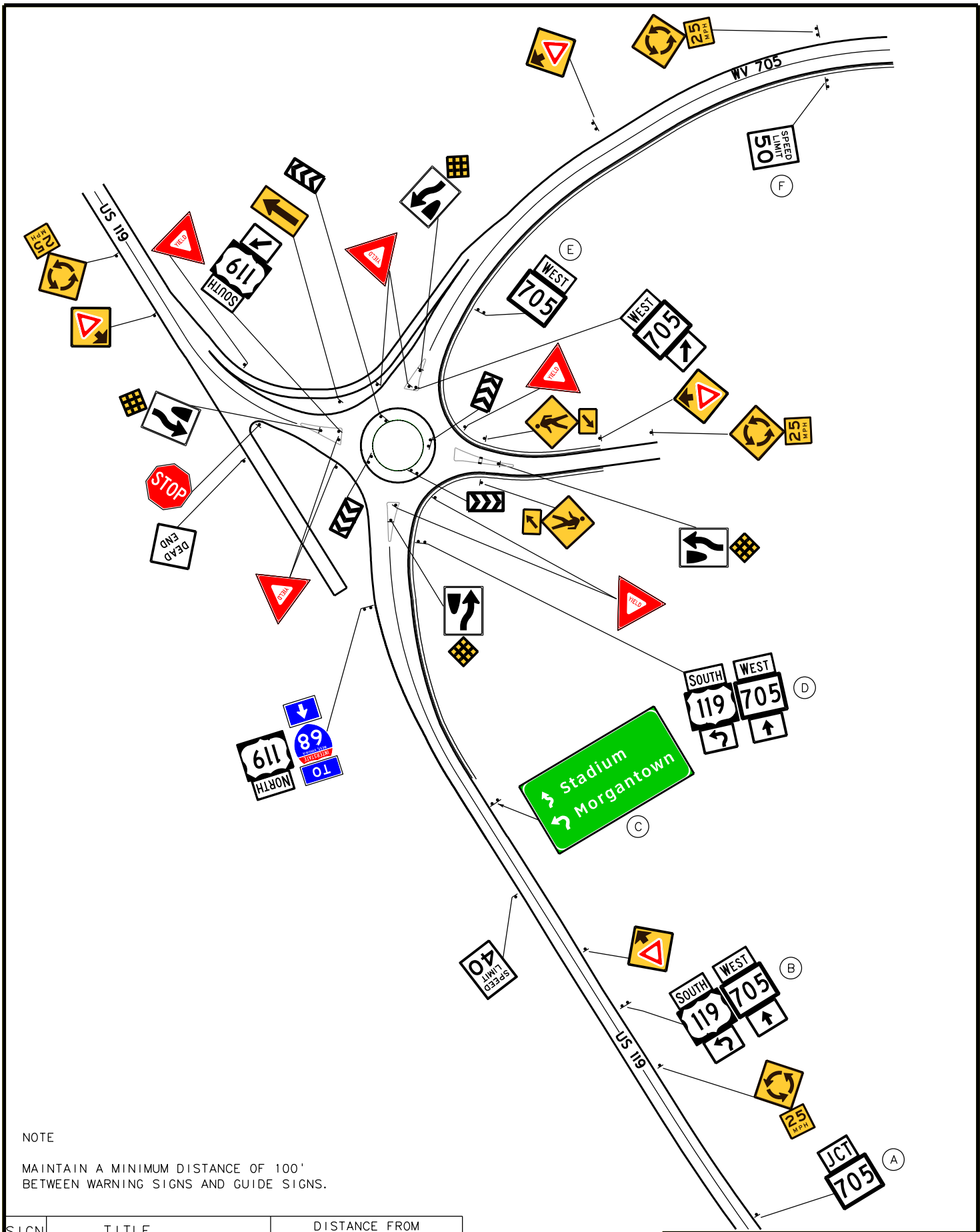

NOTE
 MAINTAIN A MINIMUM DISTANCE OF 100'
 BETWEEN WARNING SIGNS AND GUIDE SIGNS.

SIGN	TITLE	DISTANCE FROM CROSSROAD INTERSECTION
A	JUNCTION MARKER	700' to 800'
B	ADVANCE ROUTE TURN ASSEMBLY	400' to 600'
C	DESTINATION SIGN	400' to 600'
D	DIRECTIONAL ASSEMBLY	0' to 100'
E	CONFIRMING SIGN	100' to 250'
F	SPEED LIMIT SIGN	200' to 350'

FIGURE 11B
 SIGNING FOR
 MULTI-LANE ROUNDABOUT

2.2.12 Signing for Mandatory Truck Brake Check Areas (R13-2A, R13-2B, R13-2C, D5-13, D5-14)

Mandatory Truck Brake Check Areas are typically placed in advance of a steep downgrade where trucks are required to stop and check their brakes. Typical signing on conventional two lane roadways in order of appearance are the following: TRUCKS MUST STOP 1/4 MILE (R13-2A), TRUCKS MUST STOP 500 FT (R13-2A), ALL TRUCKS with arrow (R13-2C), and ALL TRUCKS STOP CHECK BRAKES (R13-2B). All signs shall have black legend on a white background. Where trucks are not required to stop, BRAKE CHECK AREA 1/2 MILE (D5-13) and BRAKE CHECK AREA with arrow (D5-14) signs having white legend on a blue background should be used instead. See Figure 12.

Mandatory Truck Brake Check Areas on freeways and expressways have the following signs: MANDATORY TRUCK STOP 2 MILES, BRAKE CHECK ALL TRUCKS OVER 26000 GVWR RIGHT LANE, MANDATORY TRUCK STOP 1 MILE, BRAKE CHECK ALL TRUCKS OVER 26000 GVWR 1/2 MILE, MANDATORY TRUCK STOP NEXT RIGHT, overhead sign (only where applicable) with ALL TRUCKS with down arrow, AND ALL TRUCKS with 45 degree right arrow. See Figure 13. The signs for a mandatory truck brake check area have a white background with black legend and border because stopping by trucks is required by law.

2.2.13 No Parking Signs (R8-3A)

R8-3A signs (24 by 24) are intended to be used in rural areas and in the area of entrance and exit ramps from rest areas on freeways and expressways. They shall be installed parallel to the roadway. The smaller R7 series signs (12 by 18) are intended to be installed in urban areas where speeds are low and should be installed either facing traffic or at a 45 degree angle to approaching traffic. Both types of signs ordinarily require a Commissioner's Order or City Ordinance to establish the no-parking restriction.

2.2.14 Continuous Lanes through Signalized Intersections (R4-15 and R4-16)

Continuous through lanes are sometimes provided through certain T-type signalized intersections with the approval of Traffic Engineering Division. THROUGH TRAFFIC KEEP RIGHT (R4-15) sign, RIGHT LANE DOES NOT STOP (R4-16), and/or Route Marker Assembly with RIGHT LANE (M5-3R) would be installed at approximately 500 to 600 feet spacing, depending upon the speed limit, on the approach to the signalized intersection. See Figure 10.

2.3 Warning Sign Use and Location

Warning signs have a fluorescent yellow background with black legend and border.

2.3.1 Function of Warning Signs

The function of warning signs is to alert motorists to unexpected conditions on or adjacent to the roadway. Warning signs should not be installed indiscriminately. They should be installed only after an engineering study reveals the need for a sign. Standard sign messages shall be utilized from the Sign Fabrication Manual or FHWA’s “Standard Highway Signs.” Warning signs should be placed in advance of the condition to be warned against at distances specified in Table 1 (Also found in the MUTCD) which follows. The sign design and standard number for all permissible warning signs may be found in the “Sign Fabrication Manual.”

Table 1 -Guidelines for Advance Placement of Warning Signs

Posted or 85th-Percentile Speed	Advanced Placement Distance ¹								
	Condition A: Speed reduction and lane changing in heavy traffic ²	Condition B: Deceleration to the listed advisory speed (mph) for the condition							
		0 ³	10 ⁴	20 ⁴	30 ⁴	40 ⁴	50 ⁴	60 ⁴	70 ⁴
20 mph	225 ft	100 ft ⁶	N/A ⁵	---	---	---	---	---	---
25 mph	325 ft	100 ft ⁶	N/A ⁵	N/A ⁵	---	---	---	---	---
30 mph	460 ft	100 ft ⁶	N/A ⁵	N/A ⁵	---	---	---	---	---
35 mph	565 ft	100 ft ⁶	N/A ⁵	N/A ⁵	N/A ⁵	---	---	---	---
40 mph	670 ft	125 ft	100 ft ⁶	100 ft ⁶	N/A ⁵	---	---	---	---
45 mph	775 ft	175 ft	125 ft	100 ft ⁶	100 ft ⁶	N/A ⁵	---	---	---
50 mph	885 ft	250 ft	200 ft	175 ft	125 ft	100 ft ⁶	---	---	---
55 mph	990 ft	325 ft	275 ft	225 ft	200 ft	125 ft	N/A ⁵	---	---
60 mph	1,100 ft	400 ft	350 ft	325 ft	275 ft	200 ft	100 ft ⁶	---	---
65 mph	1,200 ft	475 ft	450 ft	400 ft	350 ft	275 ft	200 ft	100 ft ⁶	---
70 mph	1,250 ft	550 ft	525 ft	500 ft	450 ft	375 ft	275 ft	150 ft	---
75 mph	1,350 ft	650 ft	625 ft	600 ft	550 ft	475 ft	375 ft	250 ft	100 ft ⁶

¹ The distances are adjusted for a sign legibility distance of 180 feet for Condition A. The distances for Condition B have been adjusted for a sign legibility distance of 250 feet, which is appropriate for an alignment warning symbol sign. For Conditions A and B, warning signs with less than 6-inch legend or more than four words, a minimum of 100 feet should be added to the advance placement distance to provide adequate legibility of the warning sign.

² Typical conditions are locations where the road user must use extra time to adjust speed and change lanes in heavy traffic because of a complex driving situation. Typical signs are Merge and Right Lane Ends. The distances are determined by providing the driver a PRT of 14.0 to 14.5 seconds for vehicles maneuvers (2005 AASHTO Policy, Exhibit 3-3, Decision Sight Distance, Avoidance Maneuver E) minus the legibility distance of 180 feet for the appropriate sign.

³ Typical condition is the warning of a potential stop situation. Typical signs are Stop Ahead, Yield Ahead, Signal Ahead, and Intersection Warning signs. The distances are based on the 2005 AASHTO Policy, Exhibit 3-1, Stopping Sight Distance, provided a PRT of 2.5 seconds, a deceleration rate of 11.2 feet/second², minus the sign legibility distance of 180 feet.

⁴ Typical conditions are locations where the road user must decrease speed to maneuver through the warned condition. Typical signs are Turn, Curve, Reverse Turn, or Reverse Curve. The distance is determined by providing a 2.5 second PRT, a vehicle deceleration rate of 10 feet/second², minus the sign legibility distance of 250 feet.

⁵ No suggested distances are provided for these speeds, as the placement location is dependent on site conditions and other signing. An alignment warning sign may be placed anywhere from the point of curvature up to the 100 feet in advance of the curve. However, the alignment warning sign should be installed in advance of the curve and at least 100 feet from any other signs.

⁶ The minimum advance placement distance is listed as 100 feet to provide adequate spacing between signs.

2.3.2 Enhancing Visibility and Emphasis of Warning Signing

There is a priority order for enhancing the visibility of warning signing, such as STOP AHEAD on the approach to an intersection. This priority order may also be used for regulatory signs. The first priority is to install an oversize warning sign. If further emphasis is needed the signs may be dual installed, flags or flashers may be installed on the sign, additional signing specifying distance to the intersection or warning area may be installed, or warning beacons or rumble strips may be installed. Some warning and regulatory signs are typically dual installed as a matter of practice. For new situations in which the traffic control for an intersection has been modified, a plaque indicating NEW or NOTICE with black legend on a yellow background may be installed above the warning sign.

2.3.3 Intersection Advance Warning Signing W2-1, W2-2, W3-1, and W3-2

Advance warning signing for intersections should be considered where the intersection sight distance does not meet the safe stopping requirements at the prevailing operating speed of approaching traffic. Traffic Engineering Directive 203 discusses the sight distance needed for various speeds and how it should be measured. Although there are several possible signs that may be used, ordinarily only one sign should be installed to warn motorists of an intersection. The priority order for installation of warning signs on the through highway for an intersection is as follows in order of descending priority: SIDE ROAD (W2-2) or CROSS ROAD WARNING (W2-1), SCHOOL BUS STOP AHEAD (S3-1), TRUCK WARNING (W11-10), other type warning sign. If there are Intersection Direction (D2-1 or 2) signs in place and they can be seen in advance of the intersection, W2-1 OR W2-2 warning signs are not needed. On expressways, however, W11-10 signs may be installed as a supplemental sign in advance of intersections utilized by a significant number of trucks as determined by the engineer.

For speed limits less than 40 mph warning signs should be placed 300 to 600 feet in advance of the intersection or condition. For speed limits of 40 to 55 mph warning signs should be placed 500 to 1000 feet in advance of the intersection or condition. When speed limits are more than 55 mph warning signs should be placed 1000 to 1200 feet in advance of the intersection or condition. Warning signs on freeways and expressways shall be 48 by 48 while warning signs on two lane roads should normally be 30 by 30. The size of warning signs on two lane roads may be increased to 36 by 36 or 48 by 48 if it is necessary to enhance the visibility of the sign. On expressways W2-1 or W2-2 signs should be installed for all side roads which do not have a route number or are private. If the side road has a name, the name of the road may be displayed in mixed case text on a W16-8P sign mounted underneath the W2-1 or W2-2. The W16-8P shall have black legend on a yellow background to match the W2-1 or W2-2. STOP AHEAD (W3-1) and YIELD AHEAD (W3-2) signs should be installed on side street approaches to a through highway, or to approaches to a multi-way stop only where sight distance is limited or where an engineering study indicates a need.

2.3.4 Roadway Condition Signing W8-14

WATCH FOR ICE ON BRIDGE (W8-14) signs should be used on roadway approaches to bridges where ice is likely to form. This sign may be installed in the median when it would interfere with standard sign sequences such as in the area of exit ramps.

2.3.5 Horizontal Alignment Signing

A variety of Horizontal Alignment signs, Chevron Alignment signs, and Delineation may be used to advise motorists of a change in the roadway alignment. See Section 4.0 for Delineation.

2.3.5.1 Horizontal Alignment Warning Signs (Curve Signing W1-X)

Horizontal Alignment signing shall be installed on all freeway and expressways, and all roadways with more than 1,000 AADT that are functionally classified as arterials and collectors. Horizontal Alignment signs may also be used on other roadways with less than 1,000 AADT based on engineering judgment. Signs shall be installed for any curve or change in horizontal alignment which cannot be negotiated at the legally posted speed limit in accordance with Table 2 on page 30 or Table 2C-5 of the MUTCD. For existing roadways the curve should be run using a ball bank indicator or an accelerometer that provides a direct determination of side friction factors. The safe speed for curves on new roadways should be calculated. On sign upgrading projects where curve signing is being replaced, the advisory speed displayed on W13-1 signs shall be verified using a ball bank indicator or an accelerometer. Curve signing shall be in accordance with Figure 14.

CURVE WARNING signs (W1-2) on freeways and expressways shall be 48 by 48 while signs on two lane roads should normally be 30 by 30, unless emphasis is needed. A W1-2 should be used on all curves having advisory speeds between 35 MPH and 60 MPH. Where possible on four-lane facilities, a second sign should be installed in the median to supplement the sign on the right side of the road. All 48 by 48 W1-2 signs shall have advisory speed plaques (W13-1) which are 24 by 24. For 30 by 30 or 36 by 36 W1-2 signs use 18 by 18 W13-1 when the curve speed is above 30 MPH. W13-1 displaying speeds of 30 MPH or less shall be 24 by 24. The speed displayed on W13-1 shall be in five mile increments. For curves having safe operating speeds of less than 35 MPH, a TURN WARNING sign (W1-1 or W1-3) shall be used and it shall be installed similar to the W1-2 sign. W1-6 signs shall not be used on freeways and expressways.

If the safe speed at which a curve may be negotiated is equal to or no less than five MPH lower than the speed limit, a W13-1 may not be necessary. A special design TRUCK ROLLOVER sign (W1-13) may be used for turns which are utilized by an above average number of large trucks and/or recreational vehicles and the curve cannot be safely negotiated by high center of gravity vehicles at the safe operating speed for cars as determined by a ball bank indicator, accelerometer, or calculations. The size of the sign may be increased if special emphasis is needed. If used, the W1-13 shall be accompanied by a W13-1. See Figure 15.

Table 2 - Horizontal Alignment Sign Selection

Type of Horizontal Alignment Sign	Difference Between Speed Limit and Advisory Speed				
	5 mph	10 mph	15 mph	20 mph	25 mph or more
Turn (W1-1), Curve (W1-2), Reverse Curve Turn (W1-1), Curve (W1-2), Reverse Turn, (W1-3), Reverse Curve W1-4), Widening Road (W1-5), and Combination Horizontal Alignment/Intersection (W1-10) See Section 2C.07 of MUTCD to determine which sign to use	Recommended	Required	Required	Required	Required
Advisory Speed Plaque (W13-1P)	Recommended	Required	Required	Required	Required
Chevrons (W1-8) and/or One Direction Large Arrow (W1-6)	Optional	Recommended	Required	Required	Required
Exit Speed (W13-2) and Ramp Speed (W13-3) on exit ramp	Optional	Optional	Recommended	Required	Required

Note: Required means that the sign and/plaque shall be used, recommended means that the sign and/or plaque should be used, and optional means that the sign and/or plaque may be used.

2.3.5.2 Exit Ramp Horizontal Alignment Warning Signs (W13-2 and W13-3)

The driver, when exiting from a high-speed roadway onto a ramp, shall be given some warning of the roadway conditions expected on that exit ramp or at the ramp terminal. To accomplish this, several alternative signs may be used. The most common sign is the 48 by 60 ADVISORY EXIT SPEED sign (W13-2) or ADVISORY RAMP SPEED (W13-3). The W13-2 or W13-3 shall be used when the speed limit on the freeway or expressway is more than 15 MPH greater than the advisory speed on the exit ramp. The sign(s) are recommended but optional when the speed limit on the freeway or expressway is no more than 15 MPH greater than the advisory speed on the exit ramp. Additionally, there may be other options to address this situation as discussed in the following. In the case of an extreme horizontal curvature having a safe operating speed of 30 MPH or less, such as a driver would encounter in a loop ramp, the W13-3 should be replaced with a 48 by 48 RAMP CURVE sign (W1-11) with a 24 by 24 W13-1 specifying the safe operating speed on the loop.

Additionally, an EXIT SPEED ADVISORY plaque (E13-1P) is an option for advising motorists of the safe exiting speed on a loop ramp by placing the sign underneath the Exit Gore (E5-1A) sign. When used the E13-1P is combined with the E5-1A to form one sign. Placement of both type ramp warning signs will be as shown on Figure 15. On exit ramps which are relatively straight, the W13-2 sign shall be replaced with a 48 by 48 W3-1 or W13-3. The W3-1 sign should be placed 100 to 200 feet past the Exit Gore sign. On long exit ramps, the W3-1 sign should not be placed further than 1,000 feet from the R1-1 sign. On exit ramps with traffic signals controlling the ramp terminal, a 48 by 48 SIGNAL AHEAD (W3-3) sign shall be used in lieu of the W3-1 sign and be placed 100 to 200 feet past the Exit Gore sign. If required on long ramps, both a W13-2 or W13-3 sign and W3-3 sign may be erected. For ramps connecting one freeway to another freeway

W13-3 signs should be installed. The designation RAMP SPEED (W13-3) instead of EXIT SPEED should be used on long freeway to freeway connecting ramps.

2.3.5.3 Chevron Alignment Signs (W1-8)

Where additional emphasis and guidance are needed for a change in horizontal alignment, W1-6 or W1-8 signs should be used. On exit ramps with simple horizontal curves that cause exit speeds of 30 MPH or less, W1-6 or W1-8 signs shall be located on the outside of the curve to warn the motorist. On freeways or expressways the W1-6 shall be 30 by 60 on the ramp while W1-8 signs shall be 30 by 36 on the ramp and 36 by 48 on the mainline. W1-6 and W1-8 signs should not be intermixed in the same location. The spacing of W1-8 signs shall be based upon the curve radius, using a spacing of 40 feet for a radius of less than 200 feet and spacing of 80 feet for a radius of 200 to 400 feet. W1-8 signs shall be installed at a minimum height of four feet and a maximum height of five feet from the bottom of the sign to the elevation of the nearest edge of pavement. Reflective post inserts should be installed to enhance the visibility of the W1-6 and W1-8 signs. Additional details about W1-8 sign spacing can be found in Section 2C.09 of MUTCD. See Figures 14 and 15.

2.3.5.4 Merge Sign (W4-1 or W4-3)

A 48 by 48 W4-1 sign shall be erected on the through roadway of freeways approximately 500 feet in advance of the physical gore of the acceleration lane.

2.3.5.5 Signing for Roadway Transitions

2.3.5.5.1 Reduction in Traffic Lanes (W9-1R or L, W4-2R or L)

RIGHT/LEFT LANE ENDS (W9-1R or L) signs (48 by 48) followed by LANE ENDS TRANSITION (W4-2R or L) shall be used to give advance notice of a reduction in the number of travel lanes, such as the end of climbing lanes. They shall be ground mount signs and shall be dual installed on multi-lane highways as shown in Figures 3 and 16.

On freeways where an added lane such as a truck climbing lane is being dropped, an overhead sign indicating RIGHT/LEFT LANE ENDS ½ MILE should be installed to provide an additional notice that the lane is ending. Where traffic volumes are high or there are other extenuating conditions, additional overhead signs indicating RIGHT/LEFT LANE ENDS 1 MILE and RIGHT/LEFT LANE ENDS (at the beginning of taper) may be installed. Other overhead warning signs such as LANE ENDS 1000 FEET may be used in place of the W4-2 or W9-1 signs.

2.3.5.5.2 Ending of Four Lane Highways other than Freeways and Expressways (W4-2L, W5-7, W5-7A, W6-1, W6-2, W6-3, W9-1L, R4-1, R4-7A, R4-7C)

Roadway transitions are locations where four lane highways transition to two lane highways with one lane in each direction. Signing for roadway transitions should consist of DIVIDED HIGHWAY ENDS (W6-2), LEFT LANE ENDS 1000 FT (W9-1L and W5-7A), LEFT LANE ENDS 500 FEET (W9-1L and W5-7), LEFT LANE ENDS TRANSITION (W4-2L), KEEP RIGHT (R4-7A and R4-7C) DO NOT PASS (R4-1), and TWO WAY TRAFFIC (W6-3) signs. All of the warning signs shall be 48 by 48 and should be dual installed where the median is sufficiently wide. The regulatory signs should also be larger. For permanent endings the LEFT LANE ENDS 500 or 1000 FEET may be a rectangular sign installed overhead. See Figure 16 for a typical signing layout.

2.3.5.5.3 Signing for Freeway or Expressway Ending (W17-9, W17-9A, W9-1L, W5-7A, W4-2L, W5-7, R4-7A, R4-7C, R4-1, and W17-8)

Where a freeway or expressway is ending as a permanent or semi-permanent situation, a sequence of warning signing shall be installed to alert motorists. This situation typically occurs where a freeway or expressway section has been completed and the adjacent section is several years away from being completed. Signing shall consist of the following sequence of signs: FREEWAY ENDS 1 MILE (W17-9), FREEWAY ENDS 1/2 MILE (W17-9A), LEFT LANE ENDS 1500 FT (W9-1L and W5-7A), LEFT LANE ENDS 1000 FEET (W9-1L and W5-7A), LANE ENDS TRANSITION (W4-2L), KEEP RIGHT (R4-7A and R4-7C), and DO NOT PASS (R4-1). If exiting traffic is taken off the freeway or expressway at an exit ramp, an ALL TRAFFIC USE NEXT EXIT (W17-8) or ALL TRAFFIC WITH ARROW (R4-14R) sign shall be installed. Additional signing that may be required includes CURVE WARNING signing with ADVISORY SPEED plaques, ROAD CLOSED, or ALL TRAFFIC. See Figure 17.

2.3.5.6 Signing for Steep Downgrades (W7-1B, W7-3A, and W7-2)

Long, steep downgrades require a series of signs to adequately warn truck drivers. The combination of length and percent of downgrade are the primary factors used to determine whether signing is needed for downgrades. Downgrades of 5% that are longer than 3,000 feet, 6% that are longer than 2,000 feet, 7% that are longer than 1,000 feet, 8% that are longer than 750 feet, or 9% that are longer than 500 feet should require signing. Crash experience or extenuating field conditions such as the presence of a sharp curve, school, or traffic signal at the bottom of the grade may also be indicative of the need for signing. A special rectangular sign indicating TRUCKS X % GRADE NEXT X MILES (W7-2) should be installed one-fourth to one-half mile prior to the crest of the grade. A HILL sign indicating the percent grade (W7-1B) with a NEXT X MILE (W7-3A) plaque underneath shall be installed at the crest of the hill and at one-half mile increments down the grade.

Distances beyond one and one-half miles shall be to the nearest one mile. On freeways and expressways with sufficient median width the W7-1B and W7-3A signs shall be dual installed. On two-lane roads where there are sharp curves at the bottom of the grade a rectangular warning sign such as TRUCKS 15 MPH CURVES 1 MILE AHEAD may be installed prior to the sharp curves. The W7-1B signs shall be 48 by 48 for freeways, expressways, and two lane roads. The W7-3A shall be 48 by 30 for freeways and expressways and 30 by 24 for two-lane highways. See Figure 18.

2.3.5.7 Signing for Freeway Merge Areas

Freeway merge areas are locations where two freeways having two lanes or more on each approach merge with each other. Generally, a total of four lanes on the two approaches becomes three lanes beyond the merge point. The fast lane on the approach from the right merges with the slow lane on the approach from the left. Warning signing shall be installed for freeway merge areas in accordance with Figure 19.

2.3.5.8 Signal Ahead Signs and Flashers on Expressways (W3-3, W3-3F and W2-1F)

For some signalized intersections on expressways a nine feet by eleven feet fluorescent yellow extruded panel sign (W3-3F or W2-1F) shall be installed in advance of the intersections on each mainline approach. Signs will generally have two LED flashers mounted above. In addition W3-3 signs with distance plaques of $\frac{1}{4}$ or $\frac{1}{2}$ MILE (W5-6) shall be dual installed on each mainline approach at new signals. The W3-3 shall be 48 by 48 and the W5-6 shall be 30 by 24.

SIGN NO.		SIZE
A	R13-2A	96" x 66"
B	R13-2A	96" x 66"
C	R13-2C	78" x 42"
D	R13-2B	84" x 30"

NOTES:

1. ALL SIGNS HAVE BLACK LEGEND ON WHITE BACKGROUND.
2. IF STOPPING BY TRUCKS IS NOT MANDATORY, SIGN "A" SHOULD BE REPLACED WITH D5-13 AND SIGN "C" SHOULD BE REPLACED WITH D5-14. SIGNS "B" AND "D" WOULD NOT BE NEEDED. D5-13 AND D5-14 HAVE WHITE LEGEND AND BORDER ON BLUE BACKGROUND.
3. FOR ADDITIONAL DETAILS, SEE MUTCD 21.06.

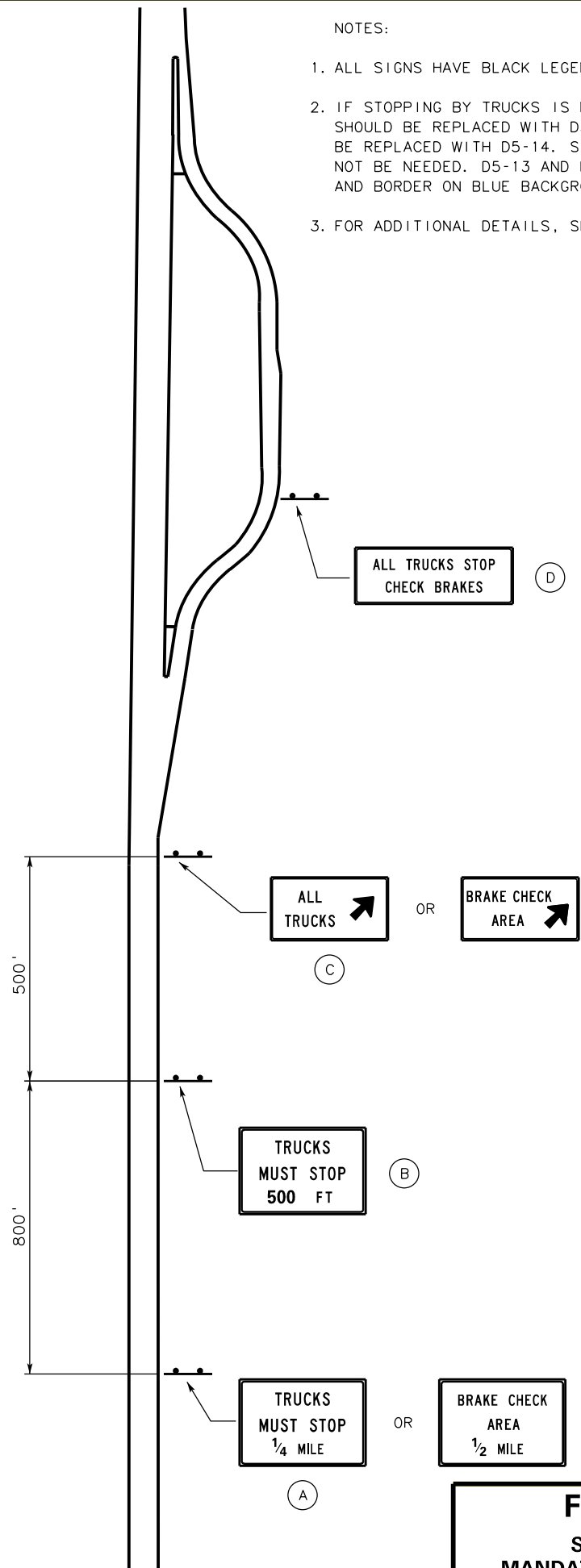
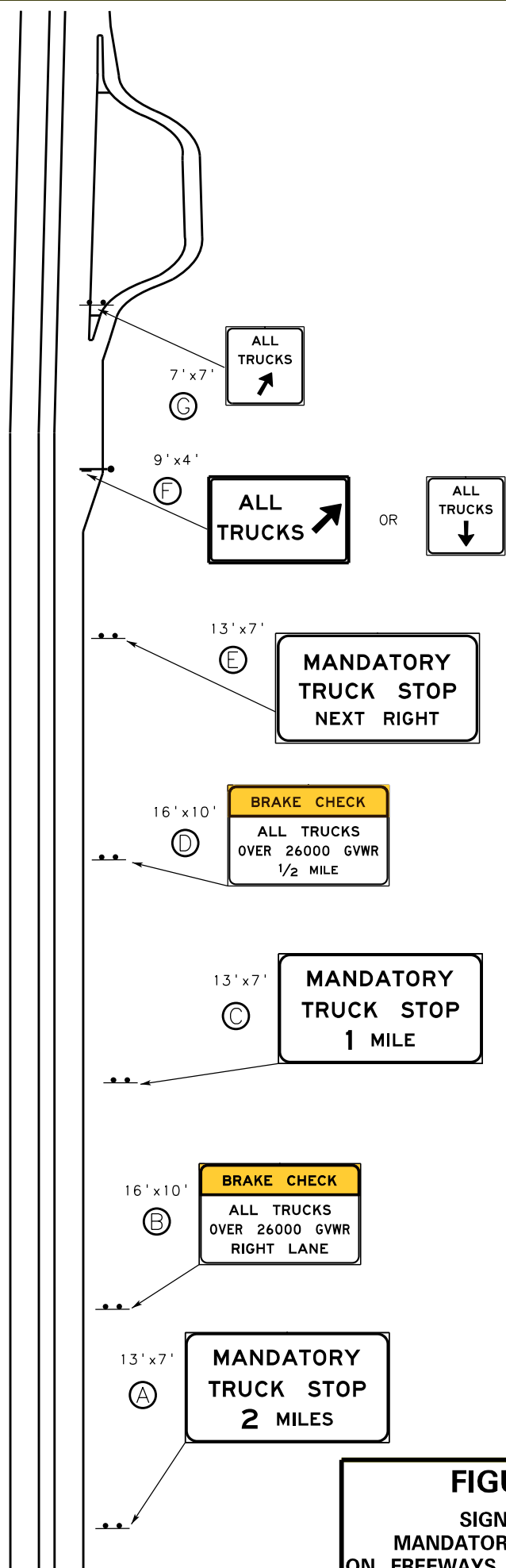

FIGURE 12
SIGNING FOR MANDATORY TRUCK STOP ON TWO LANE HIGHWAYS

SIGN NO.	SIZE
A	13' x 7'
B	16' x 10'
C	13' x 7'
D	16' x 10'
E	13' x 7'
F	9' x 4'
G	7' x 7'



NOTES:

1. MAINTAIN A DISTANCE OF 800' TO 1000' BETWEEN SIGNS.

FIGURE 13
SIGNING FOR
MANDATORY TRUCK STOP
ON FREEWAYS AND EXPRESSWAYS

FOR ADVISORY CURVE SPEEDS OF 30 MPH OR LESS, W1-6 OR W1-8 SIGNS SHALL BE ERRECTED ON THE OUTSIDE OF A TURN IN LINE WITH, AND AT RIGHT ANGLES TO, APPROACHING TRAFFIC. W1-6 AND W1-8 SHOULD NOT BE INTERMIXED AT THE SAME LOCATION.

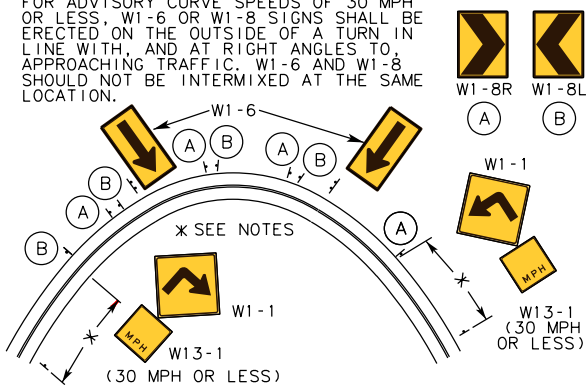

FOR ADVISORY CURVE SPEEDS OF 30 MPH OR LESS, W1-6 SIGNS SHALL BE ERRECTED ON THE OUTSIDE OF A TURN IN LINE WITH, AND AT RIGHT ANGLES TO, APPROACHING TRAFFIC.

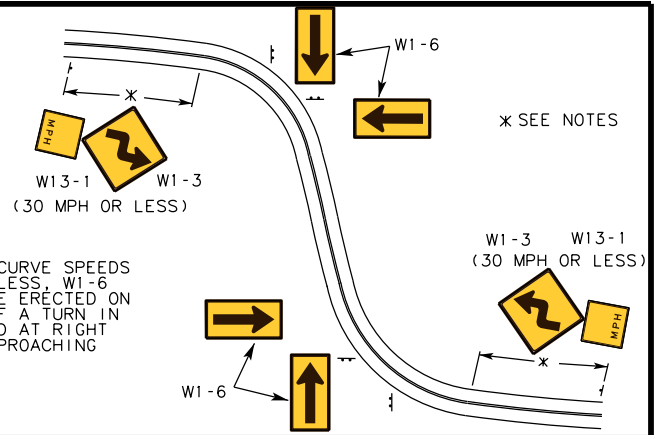

FOR ADVISORY CURVE SPEEDS OF 35 MPH OR MORE

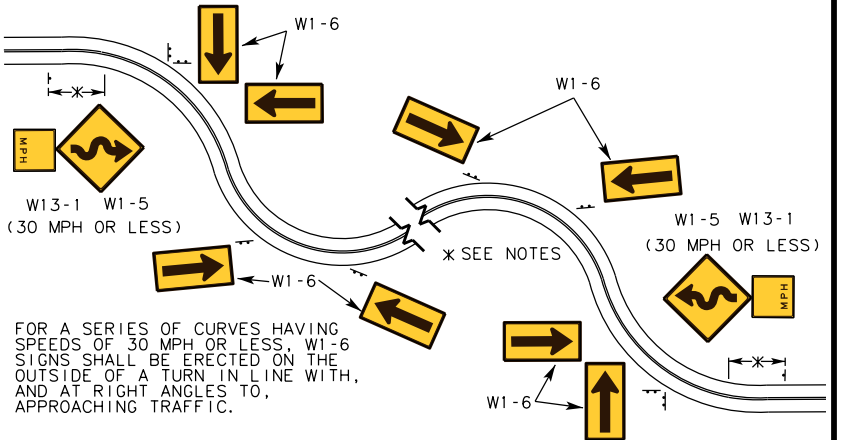
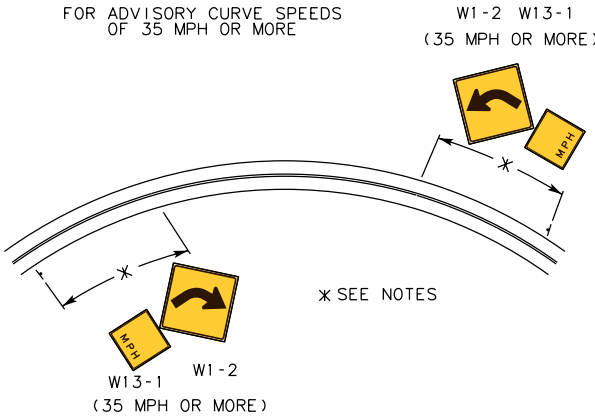

FOR ADVISORY CURVE SPEEDS OF 35 MPH OR MORE

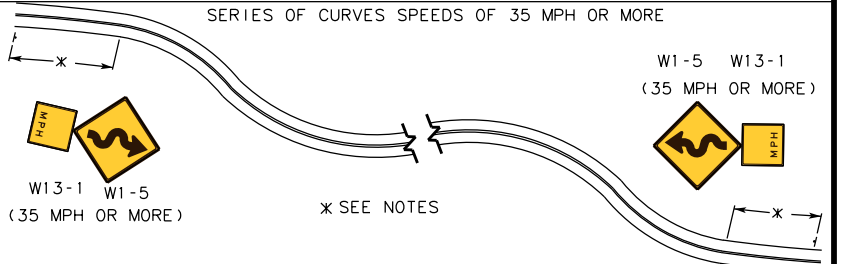
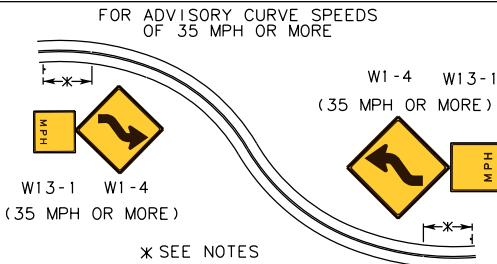

GUIDELINES FOR ADVANCE PLACEMENT OF WARNING SIGNS

POSTED OR 85TH PERCENTILE SPEED	ADVANCED PLACEMENT DISTANCE ¹								
	CONDITION A: SPEED REDUCTION AND LANE CHANGING IN HEAVY TRAFFIC ²	CONDITION B: DECELERATION TO THE LISTED ADVISORY SPEED (MPH) FOR THE CONDITION							
		0 ³	10 ⁴	20 ⁴	30 ⁴	40 ⁴	50 ⁴	60 ⁴	70 ⁴
20 MPH	225 FT	100 FT ⁶	N/A ⁵	---	---	---	---	---	---
25 MPH	325 FT	100 FT ⁶	N/A ⁵	N/A ⁵	---	---	---	---	---
30 MPH	460 FT	100 FT ⁶	N/A ⁵	N/A ⁵	---	---	---	---	---
35 MPH	565 FT	100 FT ⁶	N/A ⁵	N/A ⁵	N/A ⁵	---	---	---	---
40 MPH	670 FT	125 FT	100 FT ⁶	100 FT ⁶	N/A ⁵	---	---	---	---
45 MPH	775 FT	175 FT	125 FT	100 FT ⁶	100 FT ⁶	N/A ⁵	---	---	---
50 MPH	885 FT	250 FT	200 FT	175 FT	125 FT	100 FT ⁶	---	---	---
55 MPH	990 FT	325 FT	275 FT	225 FT	200 FT	125 FT	N/A ⁵	---	---
60 MPH	1,100 FT	400 FT	350 FT	325 FT	275 FT	200 FT	100 FT ⁶	---	---
65 MPH	1,200 FT	475 FT	450 FT	400 FT	350 FT	275 FT	200 FT	100 FT ⁶	---
70 MPH	1,250 FT	550 FT	525 FT	500 FT	450 FT	375 FT	275 FT	150 FT	---
75 MPH	1,350 FT	650 FT	625 FT	600 FT	550 FT	475 FT	375 FT	250 FT	100 FT ⁶

- NOTES:
- CURVE WARNING SIGNS ON FREEWAYS AND EXPRESSWAYS SHALL BE 48"x48" AND W13-1 SHALL BE 24"x24"
 - ON TWO LANE ROADS, W1-1 OR W1-3 SHOULD BE 30"x30" OR 36"x36", W13-1 SHOULD BE 18"x18", AND W1-6 SHOULD BE 48"x24". WHEN THE ADVISORY SPEED IS 30 MPH OR LESS, THE W13-1 SHALL BE 24"x24".

¹ THE DISTANCES ARE ADJUSTED FOR A SIGN LEGIBILITY DISTANCE OF 180 FEET FOR CONDITION A. THE DISTANCES FOR CONDITION B HAVE BEEN ADJUSTED FOR A SIGN LEGIBILITY DISTANCE OF 250 FEET, WHICH IS APPROPRIATE FOR AN ALIGNMENT WARNING SYMBOL SIGN. FOR CONDITIONS A AND B, WARNING SIGNS WITH LESS THAN 6-INCH LEGEND OR MORE THAN FOUR WORDS, A MINIMUM OF 100 FEET SHOULD BE ADDED TO THE ADVANCE PLACEMENT DISTANCE TO PROVIDE ADEQUATE LEGIBILITY OF THE WARNING SIGN.

² TYPICAL CONDITIONS ARE LOCATIONS WHERE THE ROAD USER MUST USE EXTRA TIME TO ADJUST SPEED AND CHANGE LANES IN HEAVY TRAFFIC BECAUSE OF A COMPLEX DRIVING SITUATION. TYPICAL SIGNS ARE MERGE AND RIGHT LANE ENDS. THE DISTANCES ARE DETERMINED BY PROVIDING THE DRIVER A PRT OF 14.0 TO 14.5 SECONDS FOR VEHICLES MANEUVERS (2005 AASHTO POLICY, EXHIBIT 3-3, DECISION SIGHT DISTANCE, AVOIDANCE MANEUVER E) MINUS THE LEGIBILITY DISTANCE OF 180 FEET FOR THE APPROPRIATE SIGN.

³ TYPICAL CONDITION IS THE WARNING OF A POTENTIAL STOP SITUATION. TYPICAL SIGNS ARE STOP AHEAD, YIELD AHEAD, SIGNAL AHEAD, AND INTERSECTION WARNING SIGNS. THE DISTANCES ARE BASED ON THE 2005 AASHTO POLICY, EXHIBIT 3-1, STOPPING SIGHT DISTANCE, PROVIDED A PRT OF 2.5 SECONDS, A DECELERATION RATE OF 11.2 FEET/SECOND, MINUS THE SIGN LEGIBILITY DISTANCE OF 180 FEET.

⁴ TYPICAL CONDITIONS ARE LOCATIONS WHERE THE ROAD USER MUST DECREASE SPEED TO MANEUVER THROUGH THE WARNED CONDITION. TYPICAL SIGNS ARE TURN, CURVE, REVERSE TURN, OR REVERSE CURVE. THE DISTANCE IS DETERMINED BY PROVIDING A 2.5 SECOND PRT, A VEHICLE DECELERATION RATE OF 10 FEET/SECOND, MINUS THE SIGN LEGIBILITY DISTANCE OF 250 FEET.

⁵ NO SUGGESTED DISTANCES ARE PROVIDED FOR THESE SPEEDS, AS THE PLACEMENT LOCATION IS DEPENDENT ON SITE CONDITIONS AND OTHER SIGNING. AN ALIGNMENT WARNING SIGN MAY BE PLACED ANYWHERE FROM THE POINT OF CURVATURE UP TO THE 100 FEET IN ADVANCE OF THE CURVE. HOWEVER, THE ALIGNMENT WARNING SIGN SHOULD BE INSTALLED IN ADVANCE OF THE CURVE AND AT LEAST 100 FEET FROM ANY OTHER SIGNS.

⁶ THE MINIMUM ADVANCE PLACEMENT DISTANCE IS LISTED AS 100 FEET TO PROVIDE ADEQUATE SPACING BETWEEN SIGNS.

FIGURE 14
TYPICAL LAYOUT
FOR ADVISORY CURVE SIGNING

2.3.5.9 Overhead Clearance Signing (W12-2 and W12-2P)

Signing shall ordinarily be installed on all roadways and ramps passing under bridges or underpasses when the vertical clearance is 14 feet 6 inches or less. On freeways and expressways signing shall be provided when vertical clearances are 16 feet 3 inches or less. The signing shall consist of an advance LOW CLEARANCE (W12-2) sign and a LOW CLEARANCE (W12-2 or W12-2P) sign mounted overhead on the structure. The advance sign should have a plaque underneath indicating 500 FEET (W5-7) for speeds of 55 mph or less or 1/4 MILE (W5-6) when the approach speed is more than 55 mph. The actual clearance to the nearest inch with three inches deducted to allow for frost heave shall be displayed on the sign. An additional sign with a distance plaque should be installed on freeways and expressways. Traffic Engineering Division will determine the location for advance signs. On freeways and expressways the W12-2 shall be 48 by 48 and be dual installed. On two lane roads the sign should be 36 by 36 unless a larger sign is needed for emphasis. The W12-2P shall be 78 by 24. Overhead clearances are usually different on different approaches so that signing may be needed on one approach but not on the other.

2.3.5.10 Crossing Signing (W11-1, W11-2, W11-3, W11-4, W11-5, W11-7, W11-7A, W11-11, W11-12, and W7-3A)

Various signs may be installed to warn motorists of vehicles, machinery, or animals crossing the highway. These include TRUCK CROSSING (W11-10), FARM MACHINERY CROSSING (W11-5), ATV CROSSING (W11-12), GOLF CART CROSSING (W11-11), AMISH BUGGY CROSSING (W11-7A), PEDESTRIAN CROSSING (W11-2), BICYCLE CROSSING (W11-1), HORSE CROSSING (W11-7), CATTLE CROSSING (W11-4), and DEER CROSSING (W11-3). The primary criteria for installation of these type signs is restricted sight distance and an established frequency of occurrence of the crossing maneuver. Traffic Engineering Directive 201 establishes the sight distance required to warrant installation of signs and a methodology for measuring sight distance. Signs should be installed far enough in advance of the crossing to allow motorists time to react and take appropriate evasive measures. See Table 1 for the placement of these signs. NEXT X MILE (W7-1B) plaques may be installed underneath the warning sign to indicate that the crossing maneuver occurs over an established distance.

DEER CROSSING (W11-3) sign with NEXT X MILE (W7-1B) should be installed at locations which have been identified as having an above average number of deer killed, as determined by Traffic Engineering Division personnel. On freeways and expressways the W11-3 signs shall be 48 by 48 and the NEXT X MILE (W7-3A) signs, if needed, shall be 48 by 30. The signs may be dual installed if needed for emphasis. On two-lane highways the W11-3 signs shall be 30 by 30 and the W7-3A sign shall be 30 by 24.

2.3.5.11 Bike Lanes, Routes, and Paths (W11-1, W11-1A, R3-17, R3-17A, R3-17B, D11-1, D11-1A, and D11-1B)

All signing for bicycle routes, lanes, or paths shall be in conformance with Part 9 of the MUTCD. Bicycle lanes shall be signed with the following sequence of signs: BIKE LANE (R3-17) with AHEAD plaques (R3-17A), BIKE LANE (R3-17), and BIKE LANE (R3-17) with ENDS (R3-17B) plaques. BIKE LANE (R3-17) signs and plaques should be installed in advance of the upstream end of the bicycle lane, at the downstream end of the bicycle lane, and at regular intervals along the bicycle lane as determined by engineering judgment based on site specific conditions and the prevailing speed of bicycle and other traffic. BICYCLE WARNING (W11-1) and SHARE THE ROAD (W11-1A) plaques should be installed at regular intervals based upon site conditions along a section of roadway that bicycles must share with vehicles. W11-1 and W11-1A signs shall not be installed on freeways or expressways. On expressways signs indicating BIKE ROUTE (D11-1) USE SHOULDER (D11-1A) or USE EXIT RAMP (D11-1B) may be installed as needed. Signs shall be installed only where specified by Traffic Engineering Division.

2.3.5.12 Object Marker Signing (XS-2 AND XS-15)

Object markers are used to mark obstructions within or adjacent to the roadway. An Object Marker (XS-2) shall be installed at a mounting height of four feet on each approach to bridges or other fixed objects within the clear zone. This includes approaches to bridges with or without full shoulder widths. On one way roadways and narrow bridges on two-way roadways Object Markers shall be placed on both sides of the roadway. On freeways and expressways, XS-2R and XS-2L object markers shall be placed on each side of bridges regardless of shoulder width. Where the fixed object is on the right side the XS-2R shall be installed, and when the fixed object is on the left side the XS-2L shall be installed. The yellow stripes shall slope downward at an angle of 45 degrees toward the side of the obstruction on which traffic is to pass. An Object Marker (XS-15) shall be installed on the nose of impact attenuators. See Standard Detail TP5-2 for additional details about Object Markers.

2.3.5.13 Railroad Crossing Signing (W10-1, W10-2, W10-3, W10-4, and W10-5)

Railroad Crossing Warning Signs (W10-1) shall be placed at an appropriate distance in advance of the crossing and in accordance with Standard Detail Sheet TEM-2. Where there is a crossing on an intersecting road and the edge of the tracks to the edge of the intersecting road is less than 100 feet, W10-2, W10-3 or W10-4 signs shall be installed on each approach of the intersecting road.

The LOW GROUND CLEARANCE (W10-5) sign should be installed where a “hump backed” crossing may cause long and/or low clearance vehicles to become stuck on the crossing. The sign should be placed in advance of the crossing; a second sign, with a street name or mileage plaque, may be necessary at the last site at which affected vehicles can detour.

The Division of Highways does not install or participate in the operation of railroad crossing “quiet zones”.

2.4 Guide Signs on Conventional Roads

Most guide signs have a green background with white legend and border, but US and WV Route Sign Assemblies have white background with black legend and border. Interstate Route Sign Assemblies have blue background with white legend and border.

2.4.1 General Requirements

Guide signs are essential to direct road users along streets and highways, to inform them of intersecting routes, to direct them to cities, towns, villages, or other important destinations, to identify nearby rivers, streams, parks, forests, and historical sites, and generally to give such information as will help them along their way in the most simple, direct manner possible.

Conventional highways have two or more lanes with speeds of 55 mph or less. They may be either rural or urban routes. Because of the lower operating speeds, the size of guide signs is smaller than those used on freeways and expressways.

2.4.2 Route Signing

One of the primary means of identifying routes and providing guidance to motorists is through use of Route Sign Assemblies.

2.4.2.1 Route Sign Assemblies (M1-1, M1-4, and M1-6)

All US and WV designated routes shall have Route Sign Assemblies at the beginning of the route and at intersections with other routes having Interstate (M1-1), US (M1-4), or WV (M1-6) designations.

2.4.2.2 Confirming Assemblies (M3-1 through M3-4, M1-4, and M1-6)

The simplest Route Sign Assembly is a Confirming Assembly which consists of a Cardinal Direction Auxiliary (M3-1 through M3-4) mounted above a Route Sign (M1-1, M1-4, or M1-6) to confirm to motorists the route on which they are traveling. The standard size of the Route Shield is 24 by 24. When the route consists of three numbers the size is 30 by 24. The M3-1 through M3-4 should be 24 by 12. A confirming Assembly should be installed just beyond the intersection on numbered routes. It should be placed 25 to 200 feet beyond the far shoulder or curb line of the intersected highway and at intervals as necessary to keep road users informed of their routes. On conventional roads in urban areas the Confirming Assembly should be spaced at maximum one-half mile intervals and in rural areas the maximum spacing should be five miles.

2.4.2.3 Junction Assembly (M2-1, M1-1, M1-4, and M1-6)

On US or WV numbered routes on approaches to an intersection with another US or WV numbered route

a Junction Assembly consisting of a Junction Auxiliary Sign (M2-1) mounted at the top of the Route Sign Assembly shall be installed. The standard size of the M2-1 is 21 by 15 on conventional roads. The Junction Assembly should be installed in the block preceding the intersection in low speed or urban areas and 700 to 800 feet from the intersection in rural areas.

2.4.2.4 Other Auxiliary Route Signs

Other Auxiliary signs that may be used with Route Sign Assemblies on conventional roads include ALT (M4-1a), BY-PASS (M4-2), TRUCK (M4-4), TO (M4-5), and END (M4-6). TO is used above a Route Sign to “trail blaze” or guide motorists to an important route such as an Interstate Route that can be reached utilizing a US or WV Route. END is used above a Route Sign on the approach to a route junction to indicate the end of a route. The standard size of these Auxiliary signs is 24 by 12.

2.4.2.5 Directional Assemblies

Directional Assemblies consist of a Cardinal Direction Auxiliary, Route sign, and Directional Arrow Auxiliary (M5 or 6 series). Various uses of Directional Assemblies are as follows: to indicate a turn being made by the route on which the motorist is traveling, to indicate the beginning of a route, to mark the end of a route, to mark turns to an intersected route, and to trail blaze to a particular route. The Advance Directional Assembly is installed in advance of the intersection while the Final Directional Assembly is the final sign that motorists see in the direction of travel. The Final Directional Assembly shall be installed on numbered routes at every intersection with another numbered route. The sign should be installed within 200 feet of the near right corner on the approach to the intersection. Where the near-corner position is not practical, the far right corner should be the preferred alternative. On the approach of a US or WV route to an interchange or another major US or WV route an Advance Directional Assembly should be installed 400 to 600 feet from the intersection. Examples of Directional Assemblies may be found on Figures 20, 22, 27, 28, and 32. Additional information regarding Directional Assemblies may be found in Section 2.4.5.4.

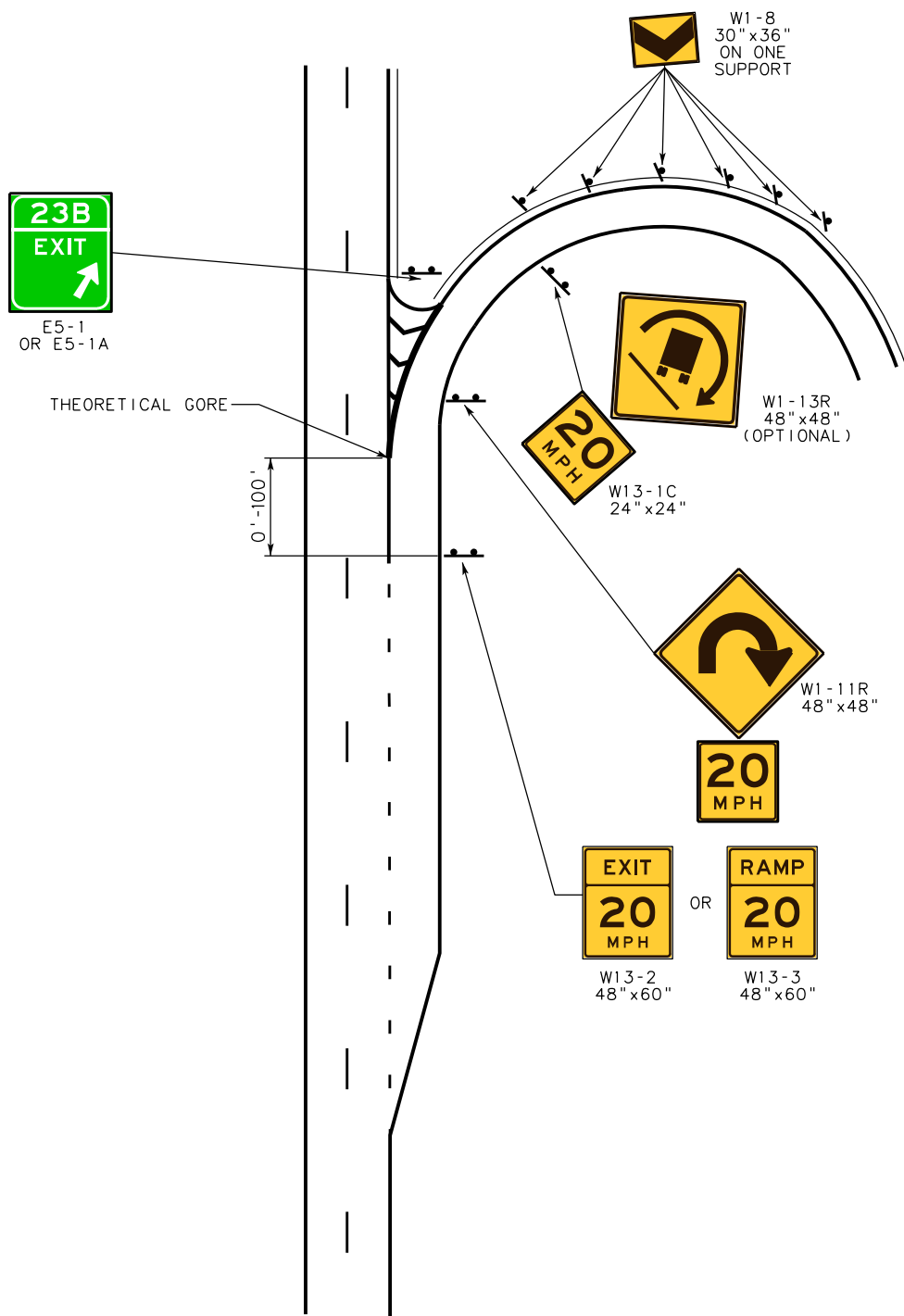

NOTE:

E5-1 SHALL BE LOCATED SO THAT RIGHT AND LEFT EDGE OF SIGN ARE 2' FROM PAVED SHOULDER.

FIGURE 15
EXIT RAMP HORIZONTAL
ALIGNMENT SIGNS

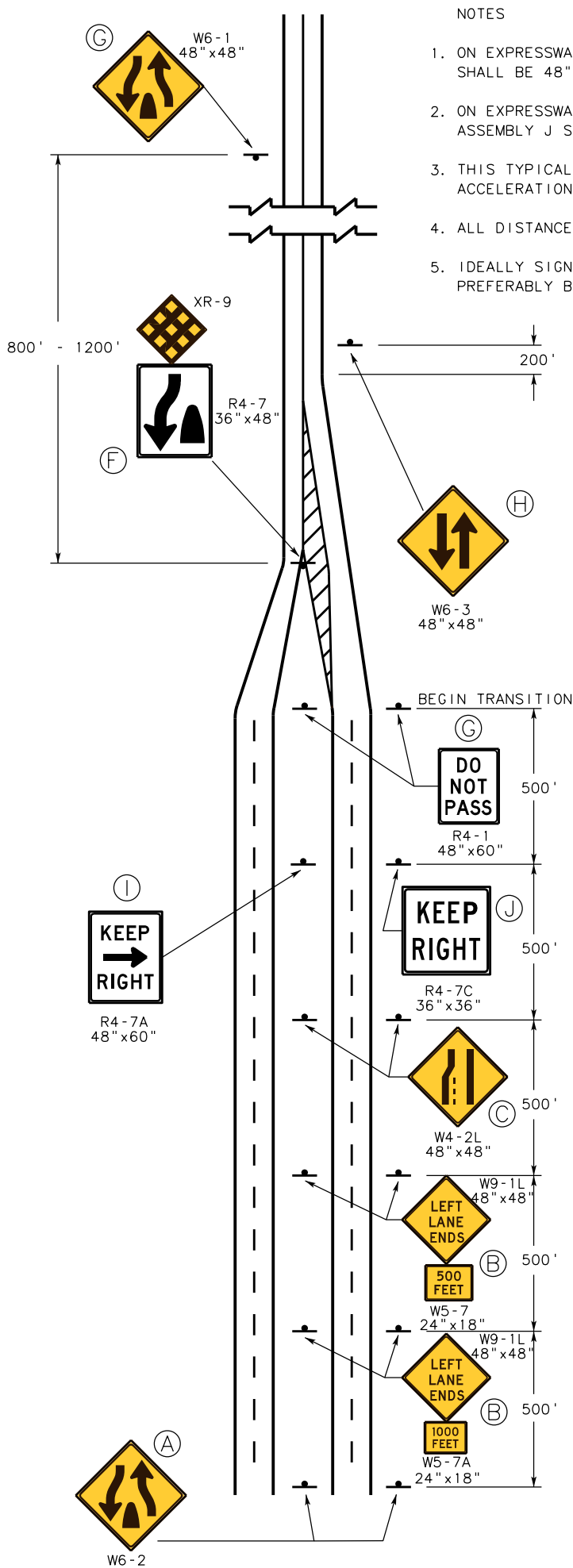

NOTES

1. ON EXPRESSWAY FACILITIES, ASSEMBLIES A, B, C, G, AND H SHALL BE 48" X 48".
2. ON EXPRESSWAYS, ASSEMBLIES F & I SHALL BE 48" X 60" AND ASSEMBLY J SHALL BE 36" X 36".
3. THIS TYPICAL LAYOUT IS NOT TO BE USED AT THE END OF AN ACCELERATION LANE.
4. ALL DISTANCES BETWEEN SIGNS ARE MINIMUM AND PREFERABLE.
5. IDEALLY SIGN B SHOULD BE MOUNTED OVERHEAD AND SHOULD PREFERABLY BE A RECTANGULAR WARNING SIGN.

FIGURE 16
SIGNING FOR LANE TRANSITION
AND BEGIN & END
DIVIDED HIGHWAY

2.4.3 Route Markers and Arrow Arrangement

Route signs and auxiliary signs shall identify all numbered highway routes. In a vertical arrangement of route signs the Interstate Route sign shall be first, followed by the US Route sign and then the West Virginia Route sign. In a horizontal arrangement the Interstate Route sign shall be on the left, followed by the US Route sign to its right and then the West Virginia Route sign on the far right. This priority order holds true regardless of the Auxiliary Route Sign used in addition to the Route Sign. Subject to this order of precedence, the lower route number shall precede a higher route number.

Within groups of Directional Assemblies information for routes intersecting from the left shall be mounted at the left in horizontal arrangements and at the top or center of vertical arrangements. Information for routes intersecting from the right shall be at the right or bottom. Straight through routes shall be at the center in horizontal arrangements and at the top in vertical arrangements. See Figures 20, 22, 27, 28, and 32. The name “WEST VIRGINIA” shall be included on the shield between the horizontal line and the route number for Interstate Route Shields (M1-1) when used in a Route Sign Assembly. When the shield is used on a guide sign, however the name “WEST VIRGINIA” shall not appear on the sign.

2.4.4 Guide Signs

The other means of guiding motorists is through the use of green and white guide signs. These signs consist of white lower-case letters following an initial upper-case letter on a green background and are used on Destination Signs (D1) and Distance Signs (D2). Arrows, action messages, distances, and county route shields may also be part of guide signs. The longer the legend on a guide sign, the longer it will take road users to comprehend and to make appropriate decisions based upon the information. For this reason guide signs should be limited to three lines of principal legend. The principal legend should be limited to place names, route numbers, and street names. Examples of D1 and D2 signs may be found on Figures 20, 22, 27, and 32.

2.4.4.1 Destination Signs (D1-1, D1-2 or D1-3)

D1-2 or D1-3 signs supply the road user information concerning the destinations that may be reached on numbered routes. Destinations may be divided into two categories –control destinations and intermediate destinations. Both categories are listed in Traffic Engineering Directive 220-1. One Control Destination with appropriate arrow shall be displayed on the D1 sign for each direction of each intersected route. A maximum of three destinations shall be displayed on the sign. The D1 sign should be installed 400 to 600 feet from the intersecting route in rural areas and at least 200 feet from either the Junction Assembly or the Final Turn Assembly. In urban areas the D1 sign should be installed within 200 feet of the intersection, or if space is limited, it may be eliminated. The next major control destination lying straight ahead shall be at the top of the sign, and below it the major control destinations to the left and to the right, in that order. The principal legend on D1 signs on two-lane US and WV Routes on the approach to another US or WV Route shall be in letters and numerals of 6-inch mixed case.

NOTES:

1. SIGNS A AND B CAN BE INSTALLED AT 2 MILES AND 1 MILE RESPECTIVELY INSTEAD OF THE LOCATIONS SHOWN.
2. SIGN I SHOULD BE USED WHEN ALL TRAFFIC MUST USE AN EXIT RAMP TO LEAVE THE FREEWAY.
3. SIGNS C OR D MAY BE INSTALLED OVERHEAD IF NEEDED.
4. INSTALL REVERSE TURN SIGN (W1-3R) AT LOCATIONS WHERE TRAFFIC MUST TURN ONTO A CONNECTOR ROAD.
5. INSTALL ROAD CLOSED, ALL TRAFFIC (R4-14AR).
6. INSTALL RUMBLE STRIP AHEAD SIGNS AND RUMBLE STRIPS AS NEEDED.
7. SIGNS F, G AND H ARE USED FOR PERMANENT ENDING OF AN EXPRESSWAY.

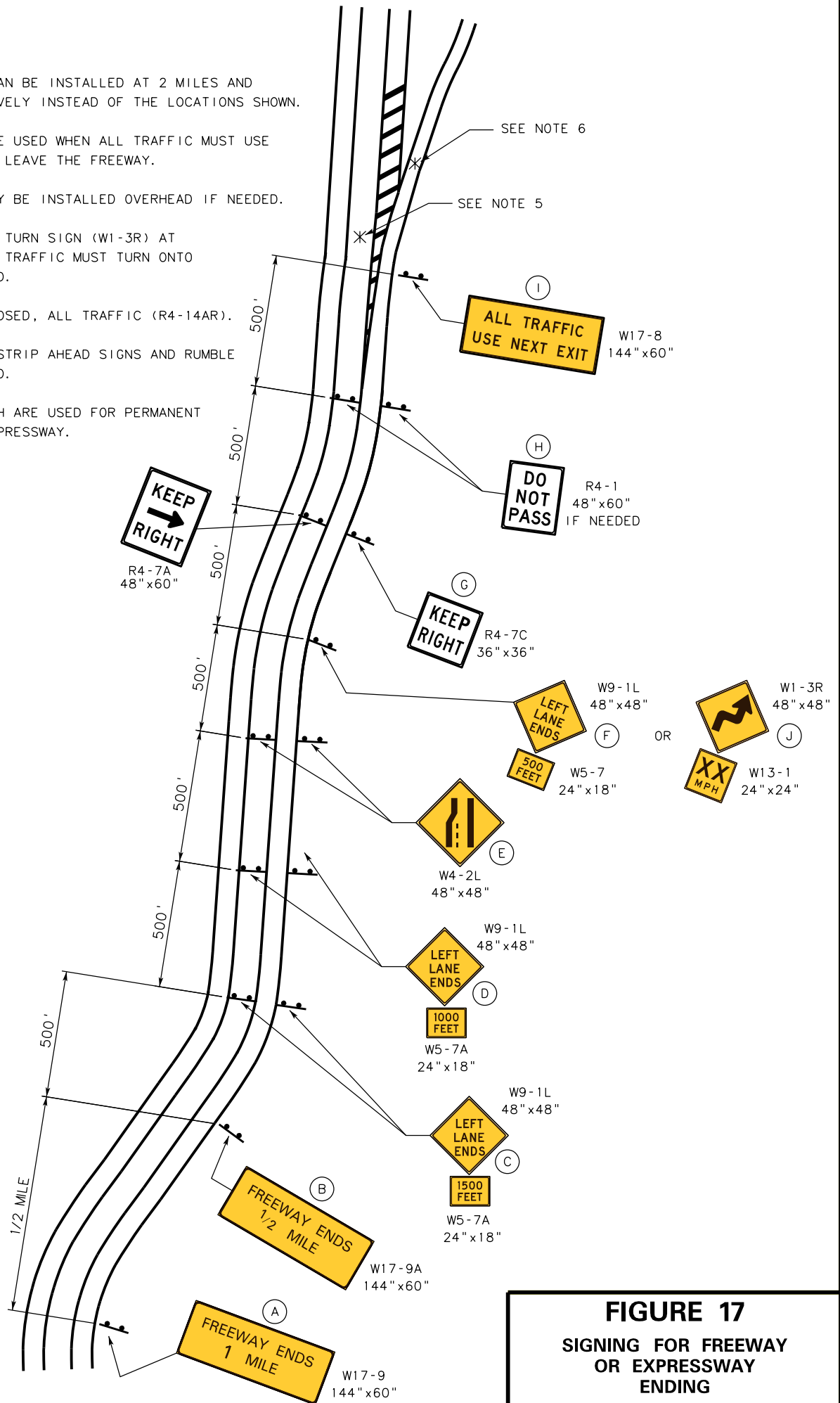

FIGURE 17
SIGNING FOR FREEWAY
OR EXPRESSWAY
ENDING

2.4.4.2 Distance Signs (D2-1, D2-2 or D2-3)

D2-2 or D2-3 signs are installed past an intersection and display the next intermediate destination and next control destination on the route along with the distance to the nearest mile to those places. Ordinarily, the distance displayed to the next city or town is to its central business district or its center. The closest destination is displayed at the top and the control destination is displayed at the bottom. A maximum of three destinations shall be displayed. The control destinations shall remain the same on all successive D2 signs throughout the length of the route until that city is reached. D2 signs should be installed on WV and US routes just past the municipal limits and 300 to 500 feet past intersections with major routes (WV or US). The principal legend on D2 signs on two-lane US and WV Routes on the approach to another US or WV Route shall be in letters and numerals of 6-inch mixed case. See Figure 20.

2.4.4.3 County Road Name Signs (D16-1, 2, or 3)

D16-1 signs should be installed on US, WV, and County routes within 50 feet of the approach to intersections with county routes. The D16-1 signs shall contain the name of the route, the county route number within a round shield, and the appropriate arrow. On the approach of US and WV routes to county routes having an ADT of 1000 or more, advance County Road Name Signs (D1-2) indicating the name of the route, the county route number within a round shield, and the legend NEXT RIGHT/LEFT, LEFT/RIGHT 500 FT, RIGHT/LEFT ¼ MILE, or other appropriate action message should be installed. The principal legend on D16-1 signs on two lane US and WV Routes on the approach to a County Route shall be in letters and numerals of 3-inch mixed case. The action message shall use 3-inch all capital letters and the shield shall be 6-inches in diameter. On multi-lane highways legend size should be the same as on expressways. See Figure 21 for an example of this signing.

2.4.4.4 Street Name Signs (D3-1)

D3-1 signs on conventional US and WV routes are normally installed by municipalities and not by the DOH.

2.4.4.5 Supplemental Destination Signs (AE5-1) Signs

AE5-1 signs may be installed on US or WV routes where it is necessary to direct motorists to stay on their route to reach certain destinations. An example of this sign is “Pt Pleasant/STRAIGHT AHEAD”. Supplemental Destination signs may also be used to direct motorists to an important city or town that is located along an approaching county route. The sign shall be installed in advance of the intersection and display the name of the destination and an appropriate action message such as NEXT RIGHT/LEFT, LEFT/RIGHT 500 FT, STRAIGHT AHEAD, or RIGHT ¼ MILE. The principal legend on AE5-1 signs on two lane US and WV Routes on the approach to a County Route shall be in letters and numerals having 4-inch mixed case. The action message shall use 3-inch all capital letters. On the approach of a conventional highway to an important County Route such as one having an ADT of 1000 or more or one leading to an

incorporated town, an Advance County Route sign may be installed. The legend size should be the same as an AE5-1 sign and an 8-inch County Route shield should be used if appropriate.

2.4.5 Guide Signing on Conventional Roads on approaches to Interchanges

2.4.5.1 Signing on Conventional Roads having one lane of traffic approaching Interchanges

The signing on conventional roads having one lane of traffic approaching an interchange should consist of a sequence containing the following signs: Junction Assembly, Advance Directional Assembly, D1-2 sign, Directional Assembly and/or Ramp Entrance Directional Assembly (AE1-4A), FREEWAY ENTRANCE Route Marker Assembly for the first ramp, Advance Route Turn Assembly and Ramp Entrance Directional Assembly (AE1-4A) and FREEWAY ENTRANCE Route Marker Assembly for the second ramp. The FREEWAY ENTRANCE Route Marker Assembly consists of a FREEWAY ENTRANCE sign (M8-1), Cardinal Marker (M1), and 45 degree down arrow (M6-2LAD or M6-2RAD). The Advance Directional Assembly may be omitted if space is limited, and if installed it should not be located where a side street or entrance to a business may be mistaken for the entrance ramp or an intersection.

On two lane roadways with speed limits above 40 mph, sign spacing between guide signs should be a minimum of 300 feet. Guide sign spacing on two lane roadways may be reduced to 100 feet where necessary due to space limitations. The D1-2 and ground mounted AE1-4A signs shall use 8 inch mixed case. On a case by case basis the AE1-4A signs may be installed on an overhead structure and be installed back to back. Advance Route Turn Directional Assemblies shall not be used on exit ramps. For interchanges of conventional roads with on-interstate

Expressways the FREEWAY ENTRANCE Route Sign Assemblies shall not be used. See Figure 32.

2.4.5.2 Signing on Conventional Roads having multiple lanes of traffic approaching Interchanges

On multi-lane conventional roads approaching an interchange the following sequence of signs should be used: Junction Guide Sign (AD5-5) or Assembly, Advance Entrance Direction (AE4-1) sign for both directions of travel on the freeway or expressway, Entrance Direction sign (AE1-4) and FREEWAY ENTRANCE Route Marker Assembly for the first ramp, Advance Directional Assembly for second ramp, Entrance Direction sign (AE1-4) and FREEWAY ENTRANCE Route Marker Assembly for the second ramp.. Consideration should be given to installing the Entrance Direction signs, Advance Entrance Direction signs, and the Advance Directional Assemblies overhead. Overhead signs may also be needed for lane control. The ground mounted AE1-4A and AE4-1 signs shall use 8 inch mixed case while the overhead mounted signs shall use 13.3 mixed case. For interchanges of conventional roads with on-interstate expressways the FREEWAY ENTRANCE Route Sign Assemblies shall not be used. See Figure 22.

2.4.5.3 Junction Assembly

This assembly should be installed 700 to 1000 feet in advance of the first interchange ramp. The Junction Assembly shall consist of a Junction Auxiliary Sign (M2-1) and a Route sign. On two lane roads the M2-1 should be 21 by 15 and on multi-lane roads it shall be 28 by 21. The M1-1, M1-4 and M1-6 Route signs should be 24 inches high on two lane roads and 36 inches high on multi-lane roads. On multi-lane conventional roads approaching an interchange a Junction Guide Sign (AD5-5) consisting of the word JCT on a green background mounted above the route number, with the legend $\frac{1}{4}$ or $\frac{1}{2}$ on the bottom of the sign should be installed. See Figures 22 and 32 for examples of this signing.

2.4.5.4 Advance Directional Assembly

This assembly should be installed 500 to 700 feet in advance of the first interchange ramp. It shall consist of a Cardinal Direction Auxiliary sign (M3-X), Route Marker (M1-1, M1-4, or M1-6), and appropriate Directional Arrow Auxiliary sign (M5-X or M6-X). It shall show the appropriate directions that the intersecting route takes with separate Cardinal Direction Auxiliary sign, Route Marker, and Directional Arrow auxiliary sign for each cardinal direction. Double-headed arrows shall not be allowed. On multilane roadways approaching interchanges the Route Marker shall be 36 by 36 or 45 by 36 (for three digit route numbers), the Cardinal Direction Auxiliary sign shall be 30 by 15, and the Directional Arrow Auxiliary sign shall be 28 by 21. On major multi-lane roadways approaching interchanges the Advance Directional Assembly shall be a white on green guide sign with Cardinal Markers, Route Shields, and appropriate action messages. Note that either this sign or the Advance Entrance Direction Sign (AE2-4A) discussed in Section 2.4.5.5 may be used (but not both) on the multi-lane approaches to interchanges. Advance Directional Assemblies shall not be used on exit ramps. See Figures 22 and 32.

2.4.5.5 Advance Entrance Direction Sign (AE2-4A)

This sign should be installed 200 to 500 feet in advance of the first interchange ramp. It shall be a white on green guide sign with Cardinal Marker, Route Shield, control destination and appropriate action message for the first ramp. A similar sign shall also be installed in advance of the interchange for the second ramp. Distances to the destinations shall not be displayed. The ground mounted AE2-4A signs shall use 8 inch mixed case while the overhead mounted signs shall use 13.3 mixed case. Control destinations for these signs can be found in the most recent version of Traffic Engineering Directive 220-1 and in Appendix B. See Figure 22.

2.4.5.6 Entrance Direction Sign (AE1-4A)

A ground-mounted Entrance Direction sign shall be erected at both the first and the second entrance ramp (in each direction of travel) to a freeway or expressway interchange. It shall be erected 50 feet or less from the ramp and usually opposite the ramp in a diamond interchange. The sign shall display on a green

background guide sign the route number(s), cardinal direction, control city and an appropriate arrow. The sign may also be installed on the left side of the approach and may be installed singularly or back to back on an overhead structure. The ground mounted AE1-4A signs shall use 8 inch mixed case while the overhead mounted signs shall use 13.3 mixed case. See Figures 22 and 32.

2.4.5.7 Freeway Entrance Ramp Sign Assembly

A Freeway Entrance Ramp Sign Assembly consisting of a FREEWAY ENTRANCE (M8-1), Cardinal Marker, Route Sign, and 45 degree down arrow shall be installed within 50 feet of each freeway ramp entrance in each direction of travel. For ramps intersecting on the right the sign assembly shall be mounted on the far right of the approach. For ramps intersecting on the left the sign assembly shall be mounted on the far left. The M8-1 shall be 36 by 21, the cardinal markers 30 by 15, the route shield 36 by 36 (or 36 by 45 for three digit routes), and the 45 degree down arrow 28 by 21. If the ramp entrance is the stem of a T intersection approach, a left or right arrow shall be used instead of the 45 degree down arrow. See Figures 22 and 32 to determine whether the 45 degree arrow should be pointed up or down.

2.4.6 Guide Signing Along WV and US Highways on Approaches to Intersections

2.4.6.1 Guide signing along two lane highways for all intersections with roads having a county route number and name

Signing should consist of an Intersection Direction sign (AD2-1 or AD2-2) located within 50 feet of the intersection displaying the name of the road (3 inch mixed case), the county route number shield (6-inch diameter), and an appropriate arrow. On multi-lane conventional roads on the approaches to county routes the AD2-1 and AD2-2 shall use 6 inch mixed case legend. If sight distance to the county route intersection is limited, if an important destination such as a city or town is located along the intersected county route, or the county route has an ADT of 1000 or more an Advance Intersection Direction sign consisting of the name of the road (4 inch mixed case), the County Route Number shield (8-inch diameter), and NEXT RIGHT/LEFT or RIGHT/LEFT 500 FT or ¼ MILE (3 inch all capital legend) should be installed 300 to 500 feet from the intersection. Where there is no name for the intersecting road no guide sign is needed. See Figure 21.

2.4.6.2 Signing on WV and US roads having one or more lanes of traffic approaching an intersection with a WV or US signed route

Signing should consist of the following sequence of signs: Junction Assembly, Advance Directional Assembly, Destination sign (D1-2 or 3), and Final Directional Assembly. The Advance Directional Assembly may be omitted if space is limited or for lower volume intersections, and if installed it shall not be located where a side street or entrance to a business may be mistaken for the intersection. On two lane roadways with speed limits above 40 mph, sign spacing between guide signs should be a minimum of 300

feet. Guide sign spacing on two lane roadways may be reduced to 100 feet where necessary due to space limitations. The D1-2 or D1-3 shall use 6 inch mixed case legend. See the side street signing on Figures 20 and 28 for an example of the signing for this type intersection. Also see Section 2.4.2 and 2.4.4 for more detailed discussion of the Junction Assembly, Advance Route Turn Directional Assembly, Destination Signs, Final Route Turn Directional Assembly, and Distance Signs.

2.4.7 Supplemental Guide Signing and Destination Trailblazing on Non-Expressways

Supplemental signing may be installed on non-expressways when it can be established that a significant segment of the motoring public has a need for such signs. Facilities for which signing may be installed include airports, animal shelters, Appalachian trail, armories, athletic fields other than high school, bird sanctuaries, bus stations, camps, larger civic centers or field houses, colleges, covered bridges, dams, Division of Highways' District or County Headquarters, downtown or business districts, and prisons. They also include dumps or landfills, ferries, fire towers, geographical landmarks, lakes, libraries, museums, governmental district offices, police stations, race tracks, ranger stations, reservoirs, train stations, and toll facilities. Examples of this type signing are COMMERCIAL AIRPORT (I-5), TRAIN STATION (I-7), LIBRARY (I-8), and VA MEDICAL CENTER (I-35).

Signing consists of a 24 by 24 I-series sign with white legend on green, blue, or brown background with appropriate symbol or word description of the type facility, such as WVU PARKERSBURG, and the appropriate arrow (I-33) installed underneath the sign. The background color of the arrow must match the background color of the sign. For important destinations where advance notice of a required turn is needed to reach the facility, a 24 by 24 sign having the name of the facility with a supplemental plaque with the message NEXT RIGHT may be installed. Note there is a different symbol for commercial/scheduled airports (I-5) than public or private/non-scheduled) airports (I-5B). Airport symbol signs shall not be rotated in direction of turn or used as arrows. See Figure 21 for an example of the signing.

2.4.8 Destination Signing for County Routes on Non-Expressways

Ordinarily, a County Road Name sign indicating the County Route Number and Name of the road is adequate. For major county routes, however, a destination sign may be installed on the approach of a US or WV Route to the county route if at least one of the following conditions is met: the county route shall have an ADT of 1,000 or greater, the destination shall be a city, town, or established unincorporated community with defined boundaries, the destination shall generate a significant number of unfamiliar motorists on a regular basis, and the destination is different than the name of the road. The Destination sign shall contain the message NEXT RIGHT/LEFT or RIGHT/LEFT 500 FT and should normally be placed 300 to 500 feet in advance of the intersection. If it is necessary to install the sign a maximum of one-quarter mile in advance, the appropriate distance should be displayed. The destination shall be displayed in 4-inch mixed case while NEXT RIGHT/LEFT, RIGHT/LEFT 500 FT, or RIGHT/LEFT ¼ MILE shall be displayed in 3-inch all capitals. See

Figure 21.

2.4.9 Byway and Backway Signing (D-24 and D-24A)

These signs may be installed by the DOH along a designated Byway or Backway to guide unfamiliar motorists who are following the Byway or Backway. The signing for a BYWAY consists of a BYWAY sign (D-24) and an appropriate M6-1A arrow. BACKWAY signing shall consist of a BACKWAY sign (D-24A) and an appropriate I-33 arrow. BYWAY signing has a white and blue background and a BACKWAY has a white and green background. The arrows associated with the signing shall match the blue or green background of the sign. The signs should be installed within one hundred feet on the approach of a main road to the Byway or Backway or at locations where the Byway or Backway turns through an intersection. In addition, a confirming sign consisting of a D-24 or D24A without an arrow should be installed within one hundred feet past an intersection where the Byway or Backway turns and also at three to five mile intervals along the Byway or Backway.

Where signs are installed along the Byway or Backway for interpretive facilities located off the roadway, the signs should be installed at the road, street or driveway leading to the site. The signs shall consist of a 24 by 24 sign indicating the name of the interpretive facility and a directional arrow or message. See Figure 23.

2.4.10 Street Name Signs/Internally Illuminated LED (D3-1)

Internally illuminated signs may be installed on busy downtown city streets at important cross streets where signs are mounted above the aim of headlights, and where there is a significant percentage of non-local traffic. The height of the sign face shall be 18 1/2 inches and the frame width shall be 36 to 78 inches in 6 inch increments. The legend size will be determined by Traffic Engineering Division. Internally Illuminated LED signs should be used.

2.4.11 Motorized Recreational Trail Signing (D27)

Motorized Recreational Trail signing may be installed on expressways and on conventional roadways. Signing on expressways consists of a thirty-inch MOTORIZED RECREATIONAL TRAIL (D27) sign mounted underneath the Advance Street Name sign (AD1-1), and a sign with a left or right arrow mounted underneath the AD2-1. Follow-through signing including confirmation signs shall also be installed. On two or four lane conventional roadways signing consists of the MOTORIZED RECREATIONAL TRAIL (D27) sign with appropriate arrow installed within one hundred feet of the intersection. Where a trail crosses a highway, signing consists of a 30-inch ATV SYMBOL sign (W11-12) with a 24 by 18 plaque indicating 500 FT (W5-7) installed approximately 500 feet from the crossing and a 30-inch W11-12 with a 21 by 15, 45 degree down arrow plaque (W16-7) installed at the trail crossing.

2.5 Guide Signing on Freeways and Expressways

2.5.1 Guide Sign Legend

Only general guidelines may be given for the determination of the legend which will be shown on guide signs. The route number, exit numbers, and road names for intersecting roadways will all be determined prior to the preliminary submission for new construction. The preliminary submission of sign plans shall establish the legend to be used.

The signing legend for interchanges should consist of the intersecting route number and the name of the interchange. The intersecting route number shall be an Interstate route, US route, WV route, County route, or a combination. The name of the interchange should be either the city or community served by the interchange or the intersecting road/street name. An interchange may also reflect the bridge name or the name of a university or airport. It may also be a combination of names when both exist. A maximum of two names may be shown for the interchange. Preferential order will be given as follows:

- A. Incorporated cities within ten miles of the interchange. First preference is given to the closest city; however, if there is a larger city within ten miles, then preference may be given either to that city or both names may be used.
- B. Unincorporated community with a post office within three miles of the interchange.
- C. The name of the intersecting road or street. In cities served by more than one interchange, the names of the streets, in most cases, shall be given to provide positive identification of the interchanges.
- D. If none of the above applies, then some other reasonable name may be given to the interchange, such as the name of an adjacent West Virginia State Park.

At freeway to freeway junctions the control destinations for the routes shall be used on the guide signs. These destinations may be found in Traffic Engineering Directive 220-1 or the latest version and Appendix A, "Control and Intermediate Destinations for Guide Signing on Interstate, US, and WV Numbered Highways." Control destinations are major destinations along each freeway to which a large percentage of non-local motorists are destined. These are the primary destinations shown on guide signs at freeway junctions or at major and intermediate interchanges. Intermediate destinations are primarily shown on Distance signs which show the distance to both the next control destination as well as one intermediate destination. Control destination cities in other states shall have the two letter state abbreviation in all capital letters with no period after the abbreviation, or comma between the destination and the state abbreviation.

NOTES

1. ON FREEWAYS AND EXPRESSWAYS W7-1B SHALL BE 48"x48" AND W7-3A SHALL BE 30"x24".
2. ON TWO LANE HIGHWAYS W7-1B SHALL BE 36"x36" AND W7-3A SHALL BE 30"x24".

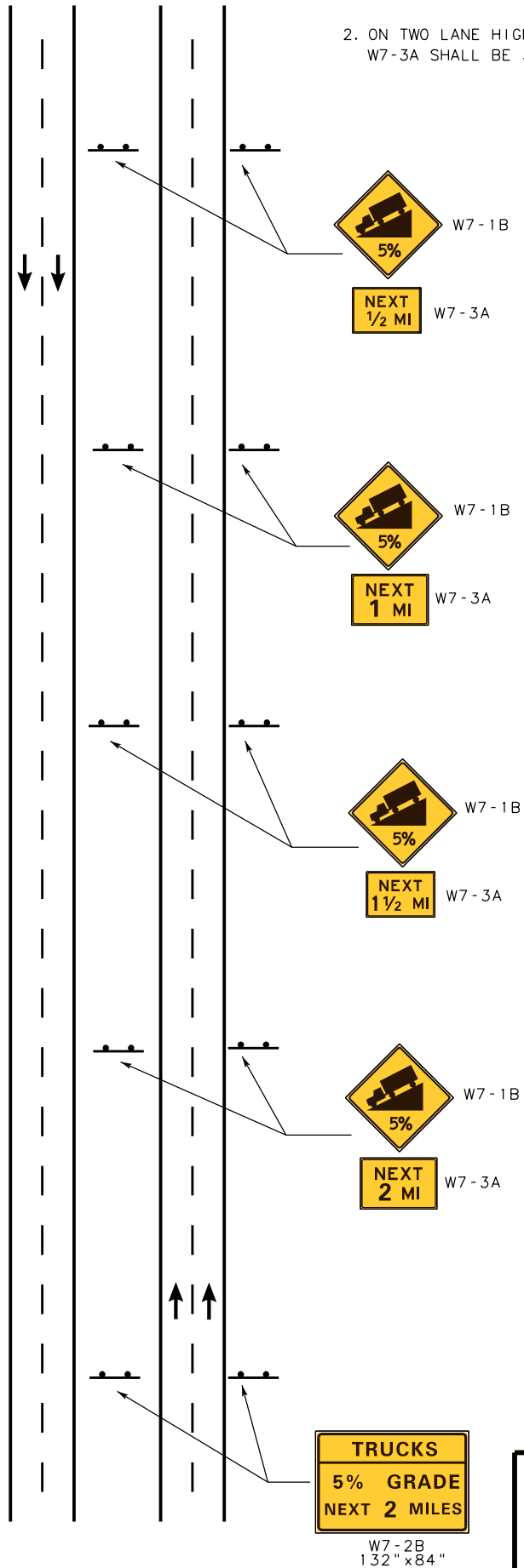

FIGURE 18
SIGNING FOR
STEEP DOWNGRADES

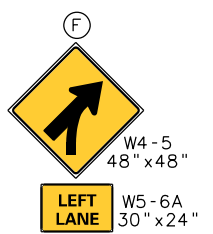
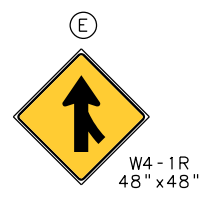
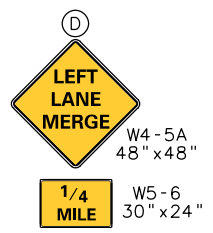
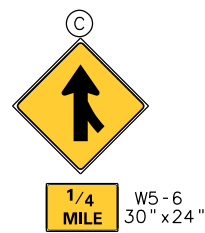
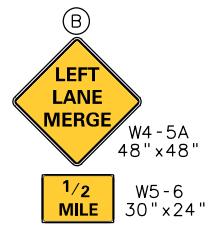
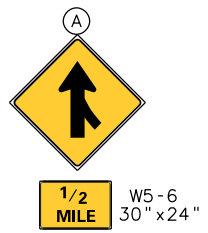
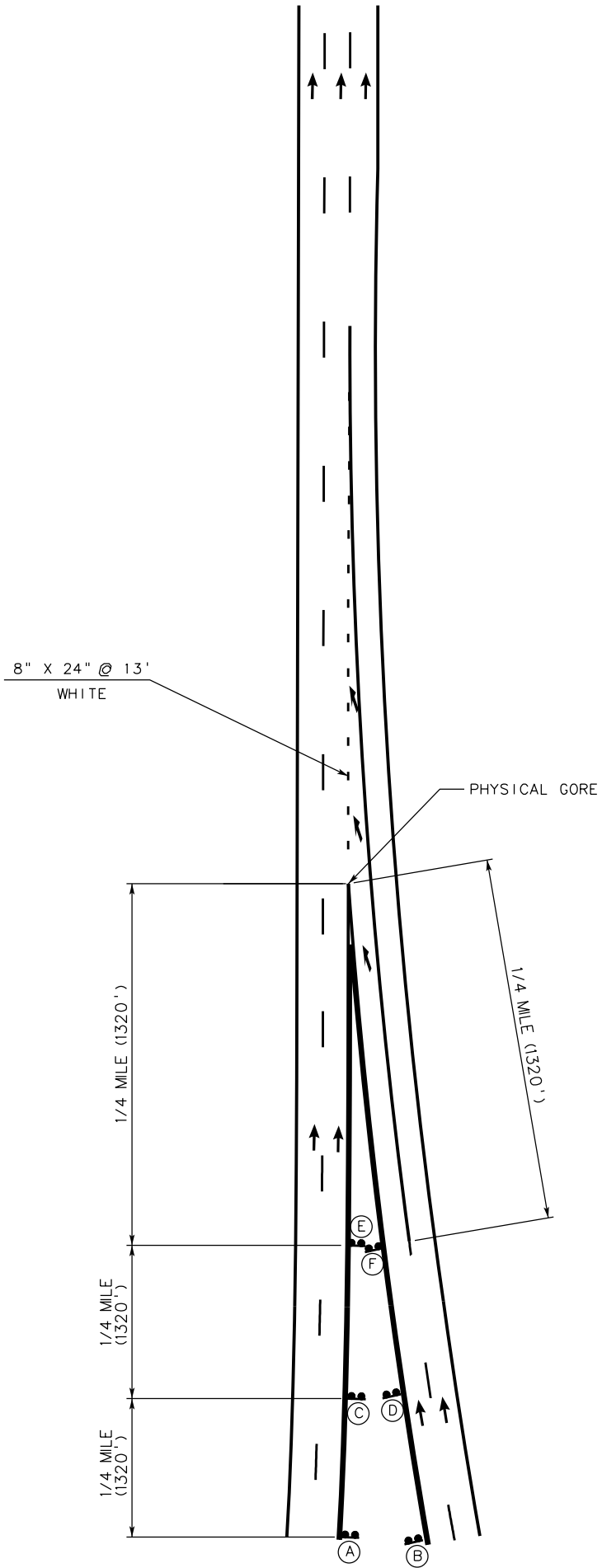
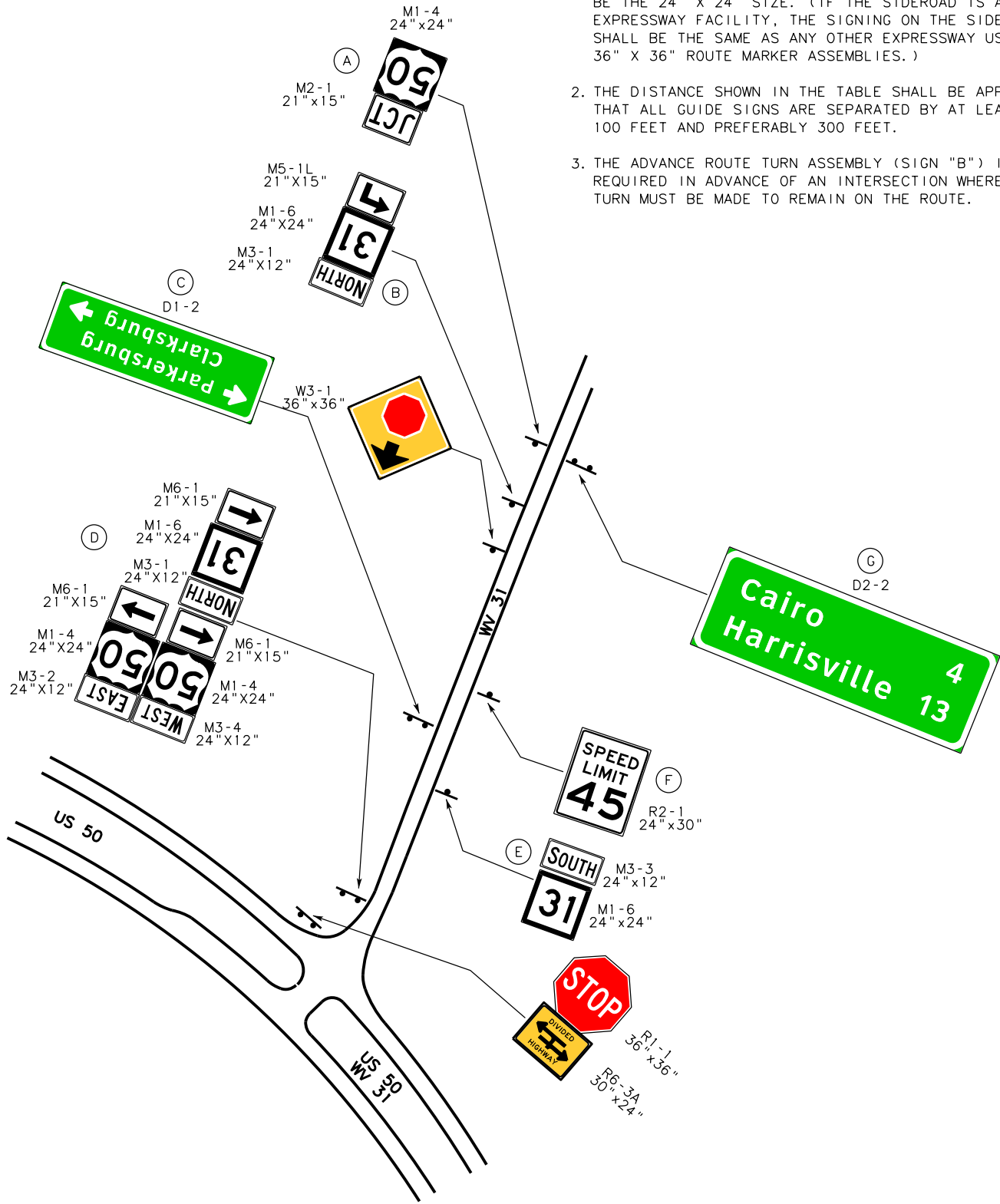

FIGURE 19
SIGNING FOR FREEWAY MERGE AREA

NOTES

1. THE SIGNING ON THE SIDEROAD IS SHOWN IN ACCORDANCE WITH THE "MANUAL ON UNIFORM TRAFFIC CONTROL DEVICES". THE ROUTE MARKER ASSEMBLIES ON THE SIDEROAD SHALL BE THE 24" X 24" SIZE. (IF THE SIDEROAD IS AN EXPRESSWAY FACILITY, THE SIGNING ON THE SIDEROAD SHALL BE THE SAME AS ANY OTHER EXPRESSWAY USING 36" X 36" ROUTE MARKER ASSEMBLIES.)
2. THE DISTANCE SHOWN IN THE TABLE SHALL BE APPLIED SO THAT ALL GUIDE SIGNS ARE SEPARATED BY AT LEAST 100 FEET AND PREFERABLY 300 FEET.
3. THE ADVANCE ROUTE TURN ASSEMBLY (SIGN "B") IS REQUIRED IN ADVANCE OF AN INTERSECTION WHERE A TURN MUST BE MADE TO REMAIN ON THE ROUTE.



SIGN	TITLE	DISTANCE FROM
		CROSSROAD INTERSECTION
A	JUNCTION MARKER	700' TO 800'
B	ADVANCE ROUTE TURN ASSEMBLY	400' TO 600'
C	DESTINATION SIGN (D1-2)	400' TO 600'
D	DIRECTIONAL ASSEMBLY	0' TO 100'
E	CONFIRMING SIGN	100' TO 250'
F	SPEED LIMIT SIGN	200' TO 350'
G	DISTANCE SIGN	300' TO 500'

FIGURE 20
SIGNING ON A WV ROUTE
ON APPROACH TO AN
INTERSECTION WITH AN
EXPRESSWAY

NOTE

1. SEE SECTION 2.4.8 FOR DISCUSSION OF ADVANCE COUNTY ROAD NAME SIGNS.

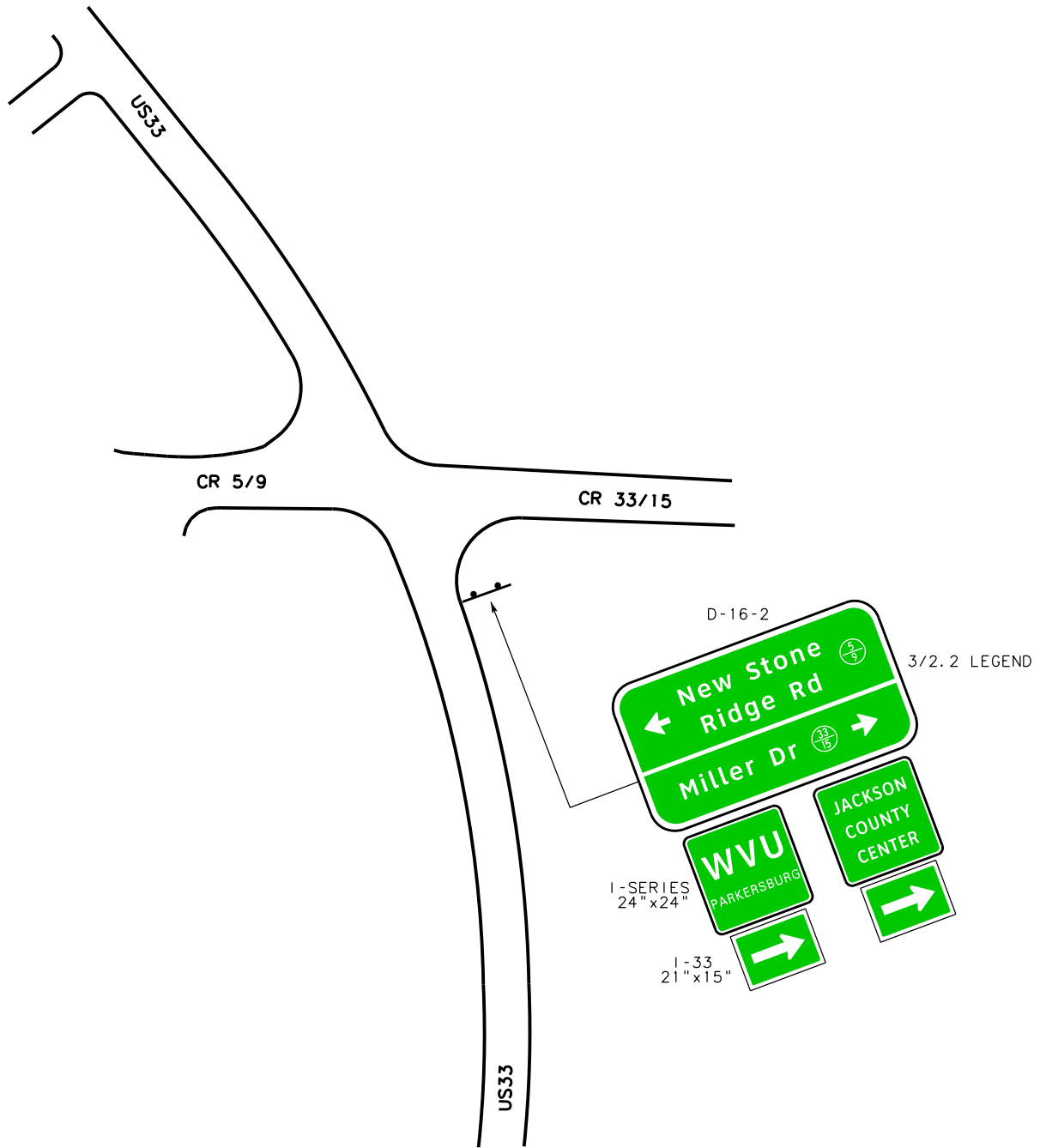

FIGURE 21
COUNTY ROAD NAME SIGN AND
SUPPLEMENTAL GUIDE SIGNING
ON NON-EXPRESSWAYS

SIGN	TITLE	DISTANCE FROM RAMP
A	JUNCTION GUIDE SIGN	700' TO 1000'
B	ADVANCE ENTRANCE SIGN	500' TO 700'
C	RAMP ENTRANCE DIRECTION	0' TO 50'
D	CONFIRMING SIGN	100' TO 250'
E	SPEED LIMIT SIGN	300' TO 500'
F	RAMP DIRECTIONAL	200' TO 700'

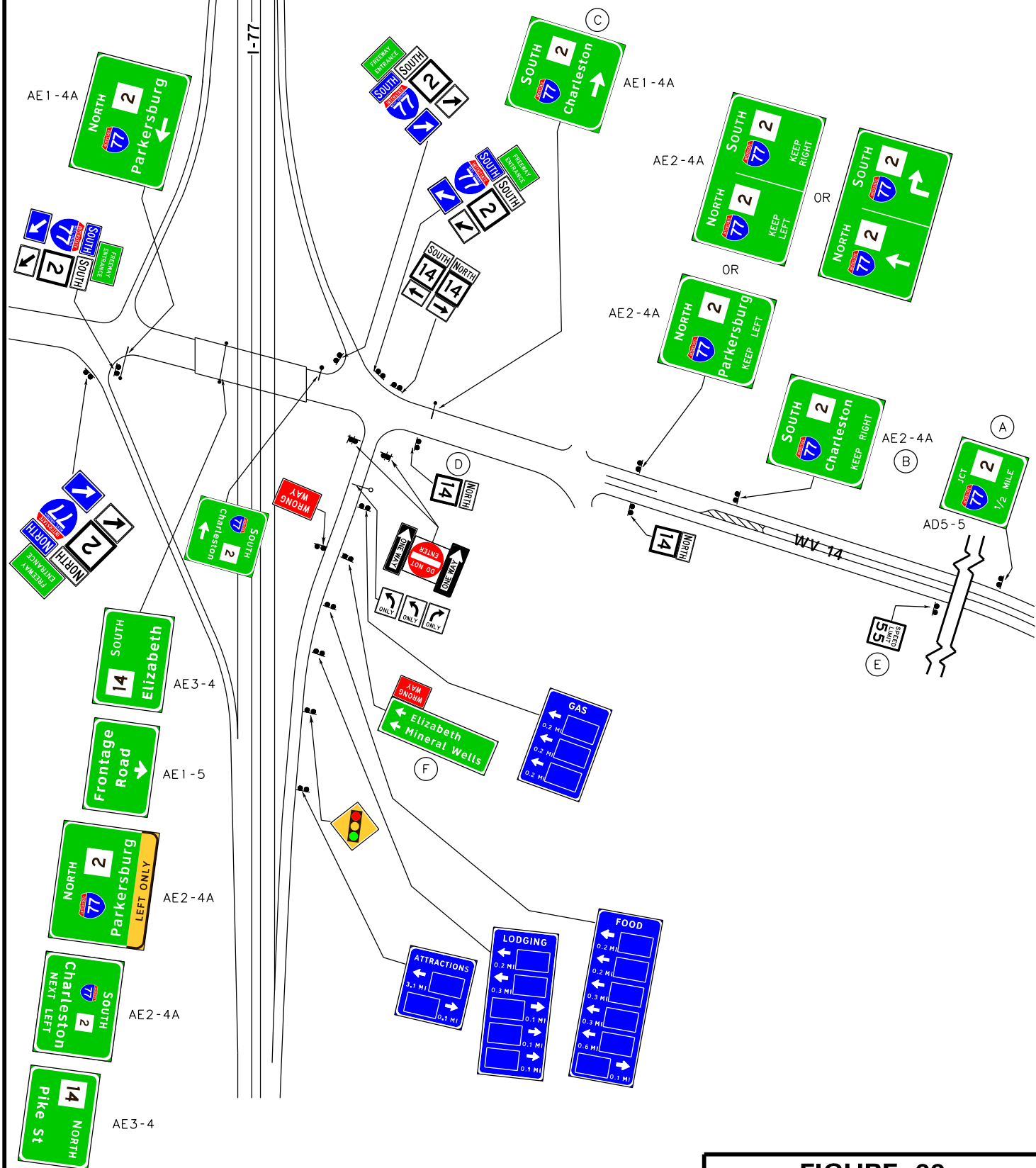
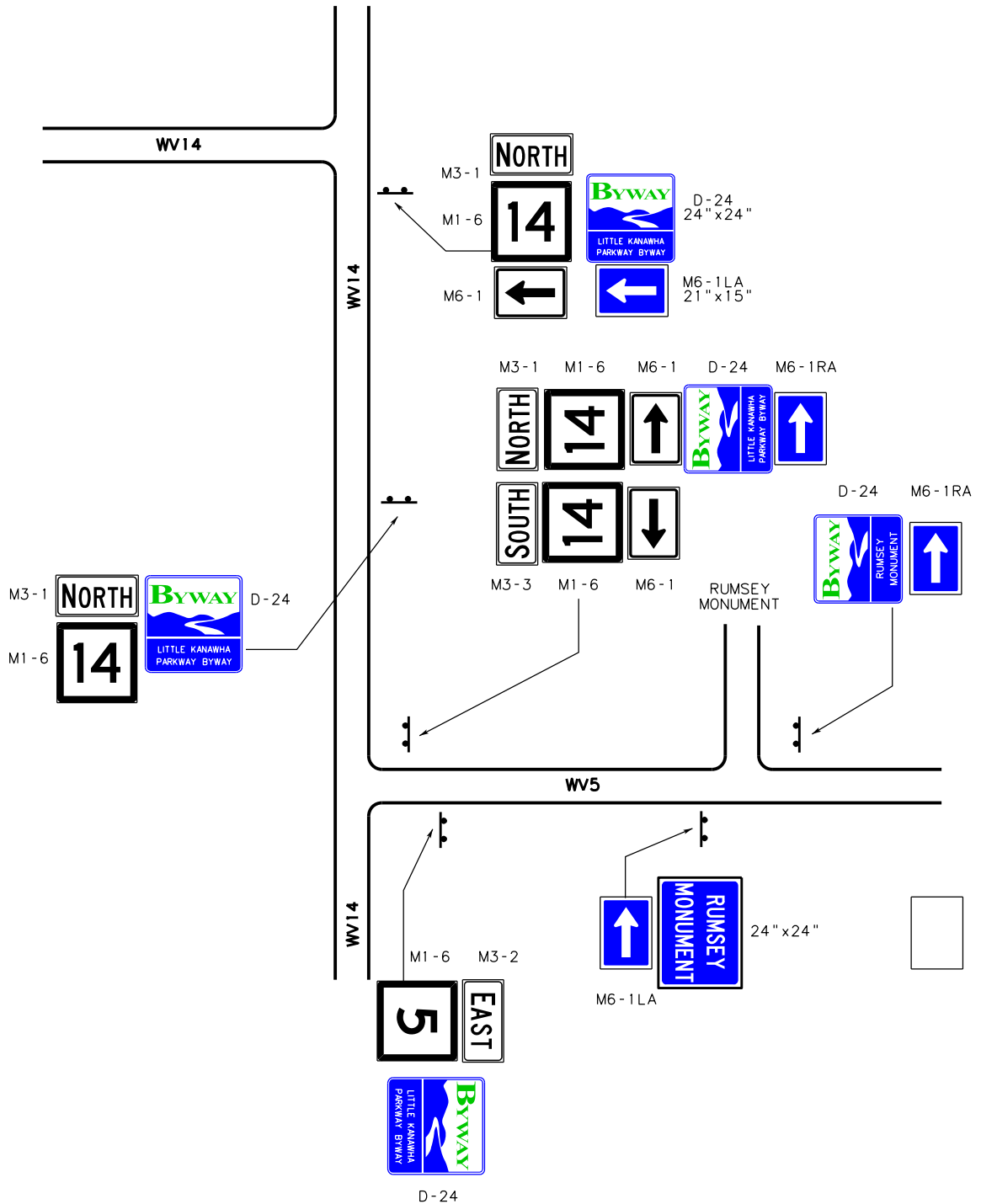

FIGURE 22
SIGNING ON WV ROUTE
HAVING MULTIPLE LANES
APPROACHING INTERCHANGE



NOTES:

1. FOR BYWAY SIGNING USE M6-1A ARROW. (WHITE ON BLUE BACKGROUND)
2. FOR BACKWAY SIGNING USE I-33 ARROW. (WHITE ON GREEN BACKGROUND)
3. D-24 - 24"x24"
4. D-33 - 21"x15"
5. M6-1XA - 21"x15"
6. BACK WAY SIGNING IS SIMILAR BUT HAS A WHITE AND GREEN BACKGROUND.

FIGURE 23
BYWAY SIGNING

NOTES:

1. OVERHEAD SIGNS ARE REQUIRED FOR THE AE3-1, AE2-2, AND AE2-1.
2. THE AE2-2 SHALL BE PLACED AS SHOWN 1000 TO 1500 FEET IN ADVANCE OF THE THEORETICAL GORE. ALSO AN OVERHEAD STRUCTURE SHALL BE ERECTED WHEN IT IS NECESSARY TO ASSIGN DRIVERS TO A PARTICULAR LANE IN ORDER FOR THEM TO STAY ON THEIR DESIRED ROUTE DUE TO LANE SPLITS.
3. MOTORIST SERVICE SIGNS SHALL NOT BE ERECTED SINCE THIS IS A JUNCTION BETWEEN TWO FREEWAY FACILITIES.
4. A SPACING OF 800' TO 1000' SHALL BE MAINTAINED BETWEEN ALL GUIDE SIGNS.

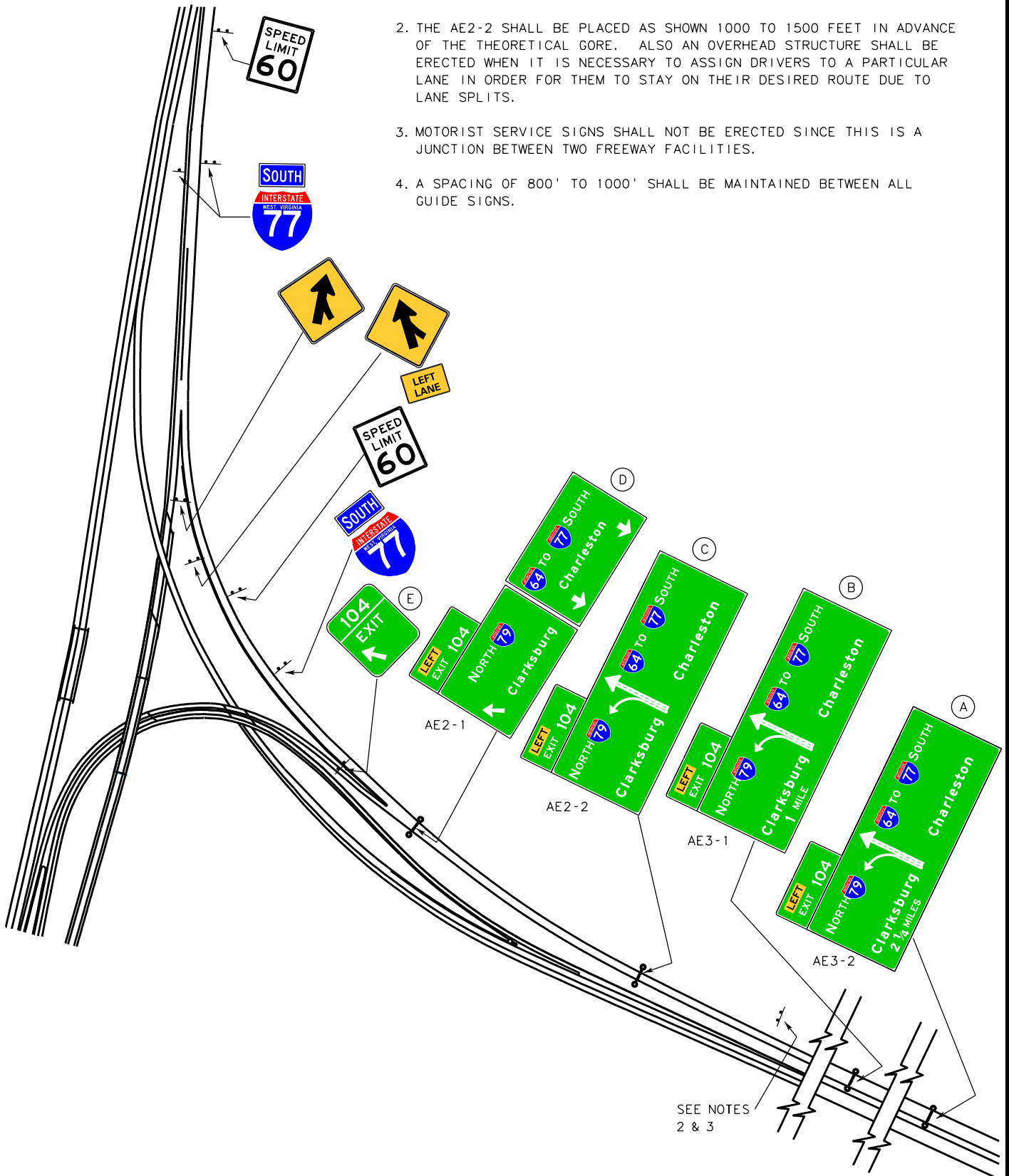

FIGURE 24
FREEWAY JUNCTION SIGNING
LEFT EXIT EXAMPLE

NOTES:

1. ALL GUIDE SIGNS SHALL BE INSTALLED OVERHEAD.
2. MOTORIST SERVICE SIGNS SHALL NOT BE ERECTED.
3. A SPACING OF 800' TO 1000' SHALL BE MAINTAINED BETWEEN ALL GUIDE SIGNS.
4. OVERHEAD SIGNS ARE REQUIRED FOR THE AE3-1, AE2-2, AND THE AE2-1 AT FREEWAY JUNCTIONS.

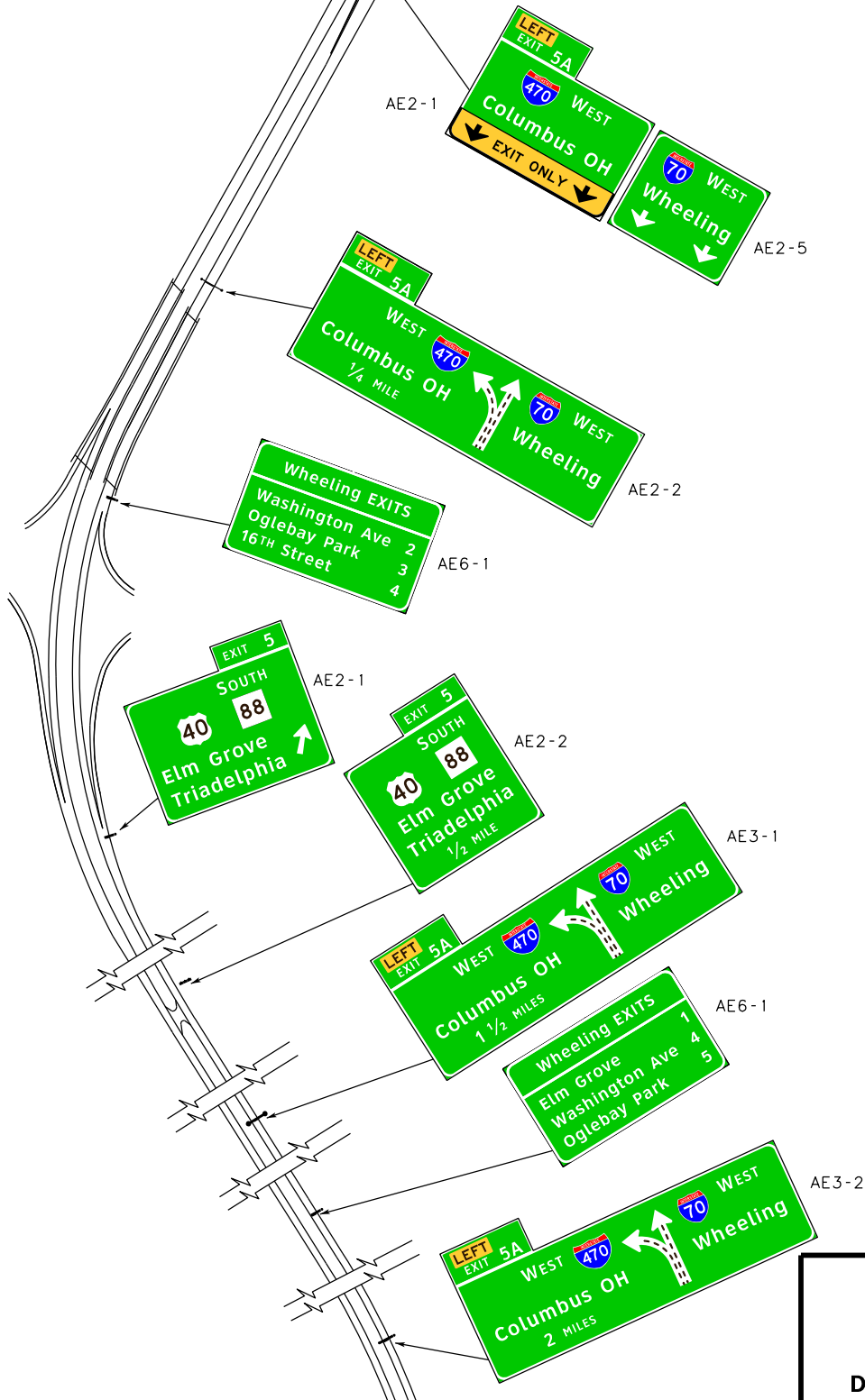

FIGURE 25
SIGNING FOR AN
INTERCHANGE LANE
DROP WITH OPTION LANE

2.5.2 General Requirements for Signing Freeway and Expressway Interchanges

2.5.2.1 Classification of Interchanges

For signing purposes, interchanges are classified as freeway junction or freeway to freeway splits, major, and intermediate. A freeway has full control of access with grade-separated interchanges. An expressway has partial control of access with at-grade intersections (and occasionally interchanges) to provide land access. Sign legend size is based on whether the classification is a freeway or expressway. Planning Division of WVDOT has mapping showing the functional classification of all highways in West Virginia. Following are descriptions of each of the classifications of interchanges:

2.5.2.1.1 Major Interchange

- A Major interchange consists of an interchange between two freeways (freeway to freeway junction or split). Freeway to freeway junctions may include option lanes or lane drops with arrow per lane signing.
- A Major interchange may also be an interchange of a freeway with an expressway (principal arterial), or freeway interchanges with high-volume multi-lane highways (urban or rural principal arterial). A major interchange may also be an interchange of a freeway with a major collector route having an ADT of 10,000 or more and a large percentage of non-local motorists. An interchanging route with a WV or US Route designation will be classified as a major interchange (for purposes of sign text selection).

2.5.2.1.2 Intermediate Interchange

Intermediate interchange on a freeway is an interchange with urban and rural routes not in the category of major or minor interchanges. This applies to all freeway interchanges with County Routes or city streets. All interchanges on an expressway are classified as Intermediate. The only difference in signing from that of Major Interchanges is the legend size. See Figure 26 for signing on a freeway. This figure does not apply to signing an interchange along an expressway.

2.5.2.2 Signing for Freeway Junctions

Signing for freeways primarily takes into account the needs of long distance, non-local motorists. For this reason signing on freeways is consistent from state to state and for both rural and urban areas. Three separate Advance Guide Signs are required at the two mile (AE3-2), one mile (AE3-1), and one thousand feet (AE2-2) (without showing distance) locations. EXIT DIRECTION (AE2-1) guide sign shall also be installed at all freeway junctions. The sign messages should contain only the route shield, name of the next control destination on the interchanging freeway route, and appropriate distances and arrows to advise motorists where the exit is located. An Exit Direction sign is never considered an advance notice but an Interchange Sequence sign (AE6-1) may be counted as one of the advance notices.

Overhead signs are required for the ONE MILE ADVANCE (AE3-1) sign, the 1000 FEET (AE2-2), and the Exit Direction/pull through sign (AE2-1) that is located at the theoretical gore of each connecting ramp. Overhead signs may also be used at the two-mile point. Additional overhead signs may be needed for multi-lane exits, splits with option lanes, lane drops, and left exit ramps. For a sample signing layout, see Figures 24 and 25. See Appendix A for the legend size of signs on the freeway.

2.5.2.3 Signing for Major Interchanges

Major Interchanges are those between a freeway and an expressway or a US or WV Route. TWO MILES (AE3-2), ONE MILE (AE3-1), ONE-HALF MILE (AE2-2), and EXIT DIRECTION (AE2-1) signs shall be installed at all major interchanges. Where space between interchanges is limited, the advance guide signs may be moved closer in and one-fourth mile increments may be displayed on the signs. An interchange sequence sign (AE6-1) may be substituted for one of the advance guide signs in areas with closely spaced interchanges. When used, interchange sequence signs shall be used over the entire route through the area and shall not be used on a single interchange basis. Interchange sequence signs are generally supplemental to the advance guide signs, are displayed in a series, and display the next two or three interchanges by name or route number in one-fourth mile increments. A total of three advance notices shall be posted for Major Interchanges. An Exit Direction sign is not considered an advance notice but an Interchange Sequence sign may be counted as one of the advance notices. See the tables in Appendix A for legend size on a freeway. The mainline signing layout for the freeway is shown in Figure 26, and the signing within the interchange area is shown in Figures 22 and 32.

2.5.2.4 Signing for Intermediate Interchanges

TWO MILES (AE3-2), ONE MILE (AE3-1), ONE-HALF MILE (AE2-2), and EXIT DIRECTION (AE2-1) signs shall be installed at all intermediate interchanges to give the driver a total of three advance notices. An intermediate interchange's signing has a smaller legend size than a major interchange. See the tables in Appendix A for sizes of legend. The signing layout for the freeway is shown in Figure 26, and the signing within the interchange area is shown in Figures 22 and 32.

2.5.3 General Requirements for Signing Intersections

Following are the various classifications of at-grade intersections.

2.5.3.1 Major Intersection

A Major intersection is an at-grade intersection of an expressway with a principal urban or rural arterial or with a major County route. Any intersection of an expressway with a WV or US Route designation is classified as a Major Intersection.

2.5.3.2 Intermediate Intersection

An Intermediate intersection is an at-grade intersection between an expressway and an urban or rural route not classified as a major intersection. This would include the intersection of expressways with local service routes (County Routes) or city streets not having a WV or US Route designation. This category of intersection is further broken down by ADT of the side road or street into two categories as follows: ADT greater than 1000 or ADT more than 250 but less than 1000. For signing projects on new alignment, route numbers may not have been established for County Routes prior to beginning of design.

2.5.3.3 Minor Intersection

A Minor intersection is the intersection of an expressway with a public road not on the State-maintained system. A public road could include any road serving at least three residences, a commercial development, or government-owned facilities such as hospitals, offices, or recreational facilities.

2.5.3.4 Land Access Intersection

A Land Access intersection is an intersection of an expressway with a privately owned road or is a stub which serves only to provide access or future access to a particular parcel of land.

2.5.3.5 Signing For Major Intersections on Expressways

These are intersections of an expressway with a US or WV numbered route. A Junction Sign (AD5-5), Advance Directional Assembly, Destination sign (D1-2 or 3), Final Directional Assembly, Confirming Assembly, Speed Limit sign, Distance sign (D2-2 or 3), and EMERGENCY STOPPING ONLY should be installed on the expressway at major intersections. An overhead guide sign may be appropriate for higher volume intersections under extenuating conditions such as an intersection within a curve or where lane control is needed. The signing on the expressway will be as shown in Figure 27.

The signing on two lane WV or US highway side road approaches to an expressway will be as shown in Figure 20.

NOTES:

1. IF A SUPPLEMENTAL SIGN IS WARRANTED AT AN INTERCHANGE, IT SHOULD BE INSTALLED A DISTANCE OF 800' - 1000' FOLLOWING THE 1 MILE SIGN OR TODS/LOGO. IT IS PREFERRED THAT GUIDE SIGNS BE 600' TO 1000' APART.
2. IF AN ADDITIONAL SUPPLEMENTAL SIGN IS NEEDED IT SHALL BE INSTALLED OUTSIDE THE SEQUENCE OF INTERCHANGE APPROACH SIGNING.
3. ON THE INTERSTATE SYSTEM THERE MAY BE LOGO SIGNS PRESENT FOR GAS, FOOD, LODGING, CAMPING AND ATTRACTIONS. IN PLACING OTHER MAJOR GUIDE SIGNS A MINIMUM SPACING OF 600' SHOULD BE MAINTAINED FROM THESE LOGO SIGNS.
4. DESTINATION LEGEND AT INTERMEDIATE INTERCHANGE IS REDUCED IN SIZE, SEE TABLES IN SECTION 8.

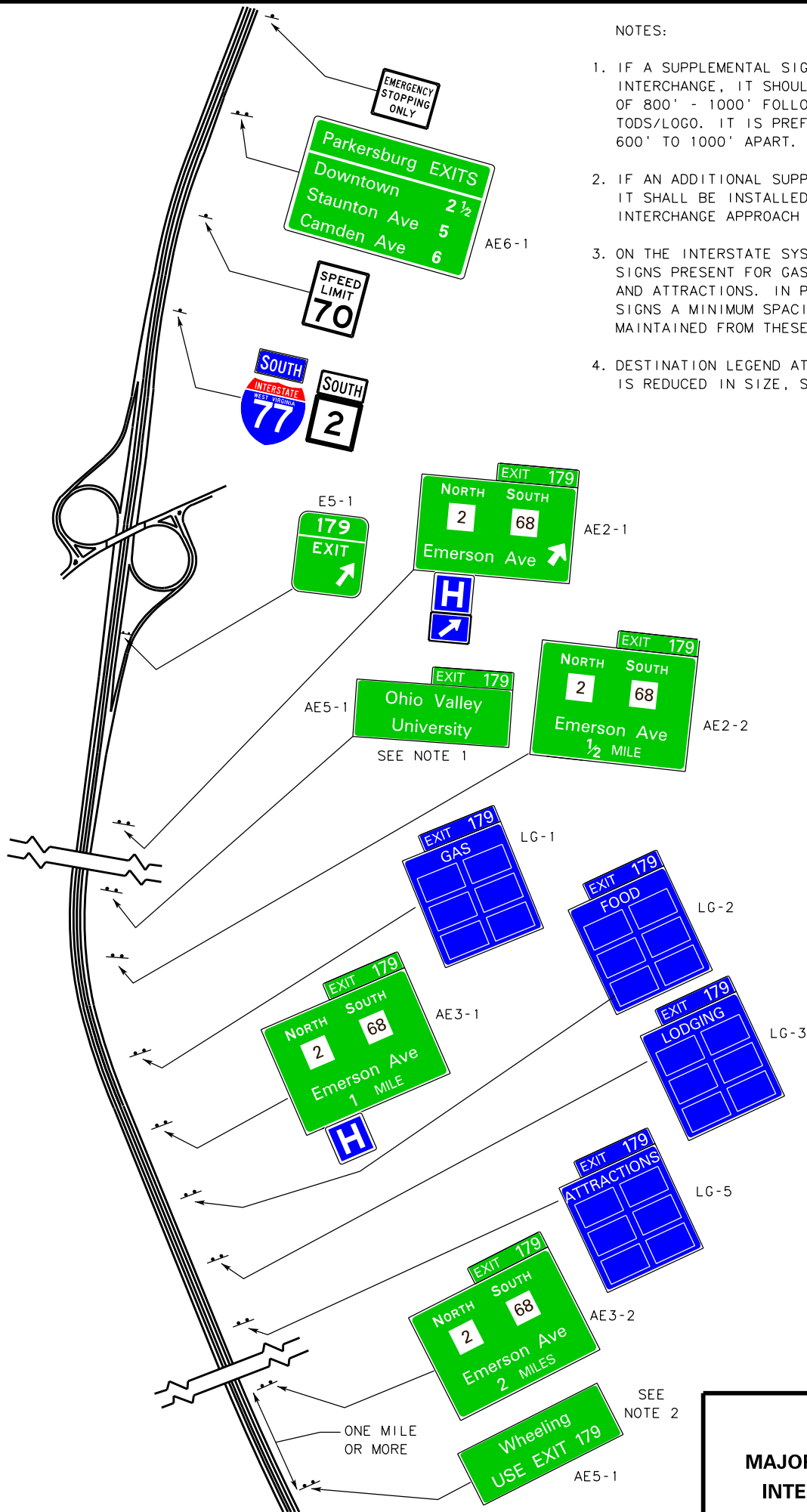
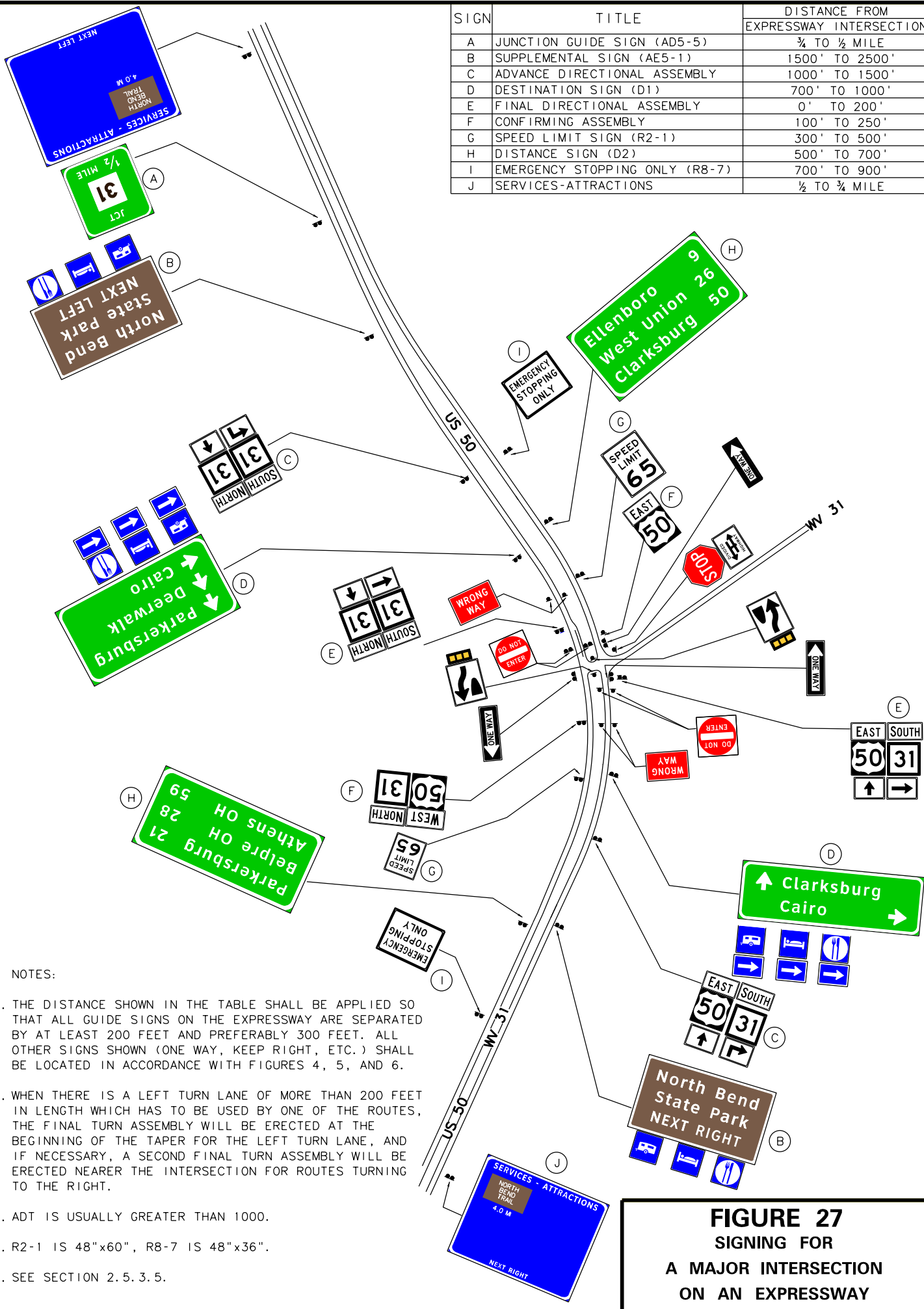

FIGURE 26
MAJOR OR INTERMEDIATE
INTERCHANGE SIGNING

SIGN	TITLE	DISTANCE FROM
		EXPRESSWAY INTERSECTION
A	JUNCTION GUIDE SIGN (AD5-5)	¾ TO ½ MILE
B	SUPPLEMENTAL SIGN (AE5-1)	1500' TO 2500'
C	ADVANCE DIRECTIONAL ASSEMBLY	1000' TO 1500'
D	DESTINATION SIGN (D1)	700' TO 1000'
E	FINAL DIRECTIONAL ASSEMBLY	0' TO 200'
F	CONFIRMING ASSEMBLY	100' TO 250'
G	SPEED LIMIT SIGN (R2-1)	300' TO 500'
H	DISTANCE SIGN (D2)	500' TO 700'
I	EMERGENCY STOPPING ONLY (R8-7)	700' TO 900'
J	SERVICES-ATTRACTIONS	½ TO ¾ MILE



NOTES:

1. THE DISTANCE SHOWN IN THE TABLE SHALL BE APPLIED SO THAT ALL GUIDE SIGNS ON THE EXPRESSWAY ARE SEPARATED BY AT LEAST 200 FEET AND PREFERABLY 300 FEET. ALL OTHER SIGNS SHOWN (ONE WAY, KEEP RIGHT, ETC.) SHALL BE LOCATED IN ACCORDANCE WITH FIGURES 4, 5, AND 6.
2. WHEN THERE IS A LEFT TURN LANE OF MORE THAN 200 FEET IN LENGTH WHICH HAS TO BE USED BY ONE OF THE ROUTES, THE FINAL TURN ASSEMBLY WILL BE ERECTED AT THE BEGINNING OF THE TAPER FOR THE LEFT TURN LANE, AND IF NECESSARY, A SECOND FINAL TURN ASSEMBLY WILL BE ERECTED NEARER THE INTERSECTION FOR ROUTES TURNING TO THE RIGHT.
3. ADT IS USUALLY GREATER THAN 1000.
4. R2-1 IS 48"x60", R8-7 IS 48"x36".
5. SEE SECTION 2.5.3.5.

FIGURE 27
SIGNING FOR
A MAJOR INTERSECTION
ON AN EXPRESSWAY

2.5.3.6 Signing for Intermediate Intersections on Expressways

These are intersections of an expressway with a County Route or City Street. Guide signing on the expressway consists of an Advance Intersection sign (NEXT RIGHT/LEFT or ¼ MILE) (AD1-1 or 2) and an Intersection Direction (AD2-1 or 2). Signing on the intersecting road and additional signing on the expressway would depend on the estimated traffic volumes expected on the intersecting road.

1. Estimated traffic volume on the intersecting roadway greater than 1,000 vehicles per day. - The intersecting road shall have a Junction Assembly, a Destination sign (D1-1 or 2), a Directional Assembly and a STOP sign with DIVIDED HIGHWAY plaque (R6-3 or R6-3A). On the expressway an Advance Intersection sign (AD1-1 or 2), Intersection Direction sign (AD2-1 or 2), Confirming Assembly, Speed Limit sign, and Distance sign (D2-2 or 3) shall be added. For closely spaced intersections the speed limit sign and the Distance sign may serve more than one intersection. Typical signing layout for the expressway and the side road would be similar to that on Figure 28.
2. Estimated traffic volume on the intersecting roadway between 250 and 1,000 vehicles per day - A STOP sign with DIVIDED HIGHWAY plaque (R6-3 or R6-3A) shall be erected on the intersecting road. On the expressway an Advance Intersection sign (AD1-1 or 2), Intersection Direction sign (AD2-1 or 2), and Confirming Assembly shall be added. If the intersection is located within one-quarter mile of another intersection, the Advance Intersection sign shall not be added. See Figure 29.

2.5.3.7 Signing for Minor Intersections on Expressway

A Minor intersection has an estimated traffic volume on the intersecting roadway less than 250 vehicles per day. For this intersection a STOP sign with DIVIDED HIGHWAY plaque (R6-3 or R6-3A) shall always be erected on the intersecting road. On the expressway signing shall include an Intersection Direction sign (AD2-1 or 2) for side roads having a name and County Route number. If the side road has no name a W2-1 or W2-2 sign shall be installed. The name of the intersecting road may be installed as a yellow panel with black legend (W16-8P) underneath the W2-1 or W2-2 sign when the intersecting road is a private road with no route number. No Confirming Assembly is needed on the mainline of the expressway. The signing layout for the expressway is shown in Figure 30.

2.5.3.8 Signing for Land Access Intersection on Expressways

A Land Access Intersection is commonly a stub constructed to allow future access to private property. It is usually paved only in the proximity to the expressway. Signing for this type intersection shall consist of a W2-1 or W2-2 sign on the expressway and a STOP sign with DIVIDED HIGHWAY plaque (R6-3 or R6-3A) on the intersecting roadway. The signing layout for the expressway would be as shown in Figure 31.

SIGN	TITLE	DISTANCE FROM CROSSROAD
A	ADVANCE INTERSECTION (AD1-2)	800' TO 1200'
B	INTERSECTION DIRECTION SIGN (AD2-2)	100' TO 300'
C	CONFIRMING ASSEMBLY	100' TO 250'
D	SPEED LIMIT SIGN (R2-1)	300' TO 500'
E	DISTANCE SIGN (D2)	500' TO 700'
F	JUNCTION ASSEMBLY	700' TO 800'
G	DESTINATION SIGN (D1)	400' TO 600'
H	DIRECTIONAL ASSEMBLY	0' TO 100'

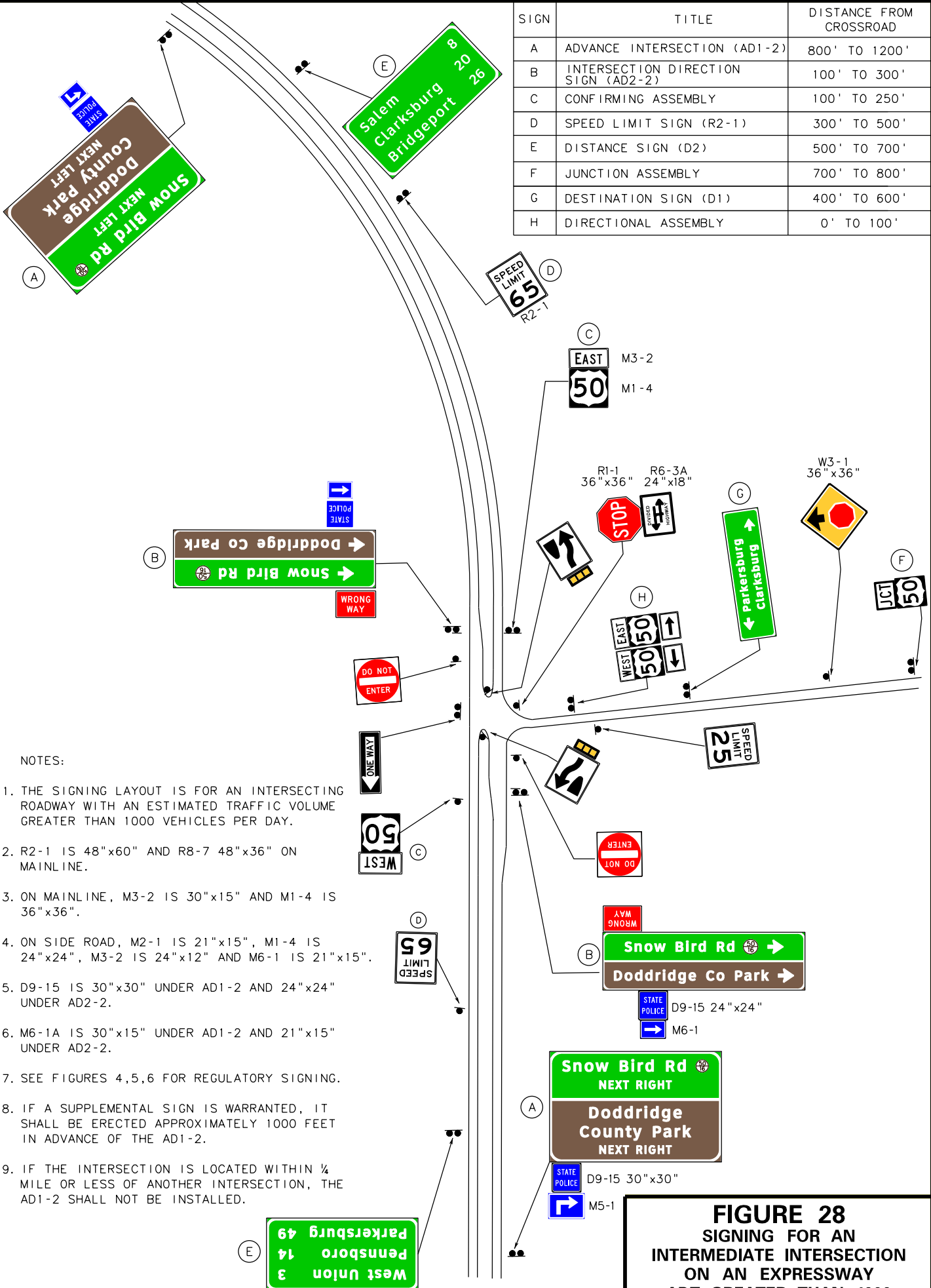

NOTES:

1. THE SIGNING LAYOUT IS FOR AN INTERSECTING ROADWAY WITH AN ESTIMATED TRAFFIC VOLUME GREATER THAN 1000 VEHICLES PER DAY.
2. R2-1 IS 48"x60" AND R8-7 48"x36" ON MAINLINE.
3. ON MAINLINE, M3-2 IS 30"x15" AND M1-4 IS 36"x36".
4. ON SIDE ROAD, M2-1 IS 21"x15", M1-4 IS 24"x24", M3-2 IS 24"x12" AND M6-1 IS 21"x15".
5. D9-15 IS 30"x30" UNDER AD1-2 AND 24"x24" UNDER AD2-2.
6. M6-1A IS 30"x15" UNDER AD1-2 AND 21"x15" UNDER AD2-2.
7. SEE FIGURES 4,5,6 FOR REGULATORY SIGNING.
8. IF A SUPPLEMENTAL SIGN IS WARRANTED, IT SHALL BE ERECTED APPROXIMATELY 1000 FEET IN ADVANCE OF THE AD1-2.
9. IF THE INTERSECTION IS LOCATED WITHIN ¼ MILE OR LESS OF ANOTHER INTERSECTION, THE AD1-2 SHALL NOT BE INSTALLED.

FIGURE 28
SIGNING FOR AN INTERMEDIATE INTERSECTION ON AN EXPRESSWAY ADT GREATER THAN 1000

SIGN	TITLE	DISTANCE FROM CROSSROAD
A	ADVANCE INTERSECTION (AD1-2)	800' to 1200'
B	INTERSECTION DIRECTION (AD2-2)	100' to 300'
C	CONFIRMING ASSEMBLY	100' to 250'

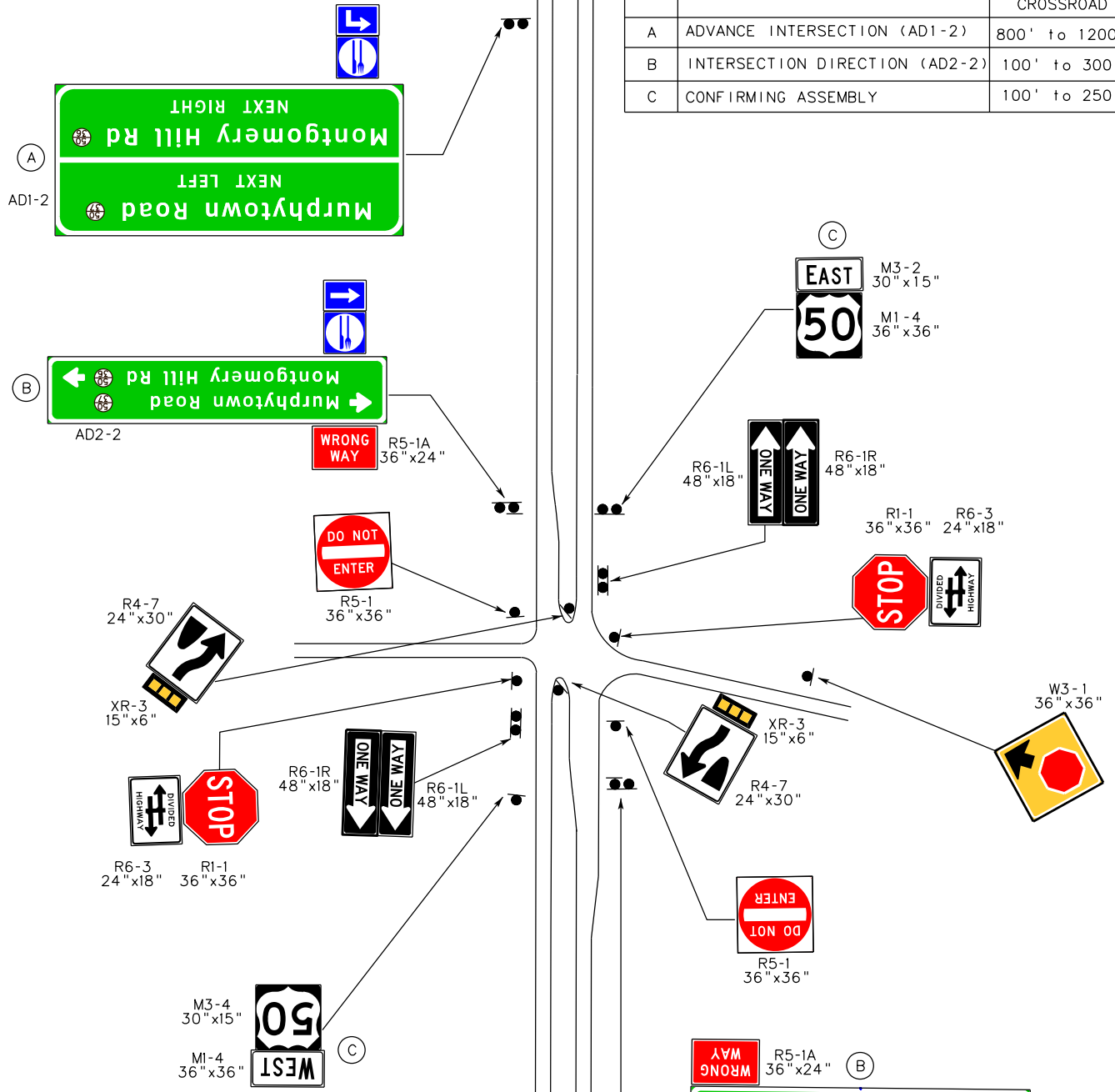

NOTES:

1. THE SIGNING LAYOUT IS FOR AN INTERSECTING ROADWAY WITH AN ESTIMATED TRAFFIC VOLUME BETWEEN 250 AND 1000 VEHICLES PER DAY. IF THE VOLUME IS LESS THAN 250, THE ADVANCE INTERSECTION SIGN AND CONFIRMATION ASSEMBLY ON THE EXPRESSWAY MAY BE ELIMINATED.
2. THE SIGNING LAYOUT SHOWS AN INTERSECTION WITH TWO DIFFERENT LOCAL SERVICE ROUTES. IF THERE IS ONLY ONE LOCAL SERVICE ROUTE FOR THE ROAD CROSSING THE EXPRESSWAY, THE LEGEND ON THE ADVANCE INTERSECTION AND INTERSECTION DIRECTION SIGNS SHALL BE ADJUSTED.
3. IF A SUPPLEMENTAL SIGN IS WARRANTED, IT SHALL BE ERECTED APPROXIMATELY 1000 FEET IN ADVANCE OF THE AD1-2.
4. SEE FIGURES 4, 5, 6 FOR REGULATORY SIGNING
5. IF THE INTERSECTION IS LOCATED WITHIN ¼ MILE OR LESS OF ANOTHER INTERSECTION, THE AD1-2 SHALL NOT BE INSTALLED.

FIGURE 29
SIGNING FOR AN INTERMEDIATE INTERSECTION ON AN EXPRESSWAY
ADT 250-1000

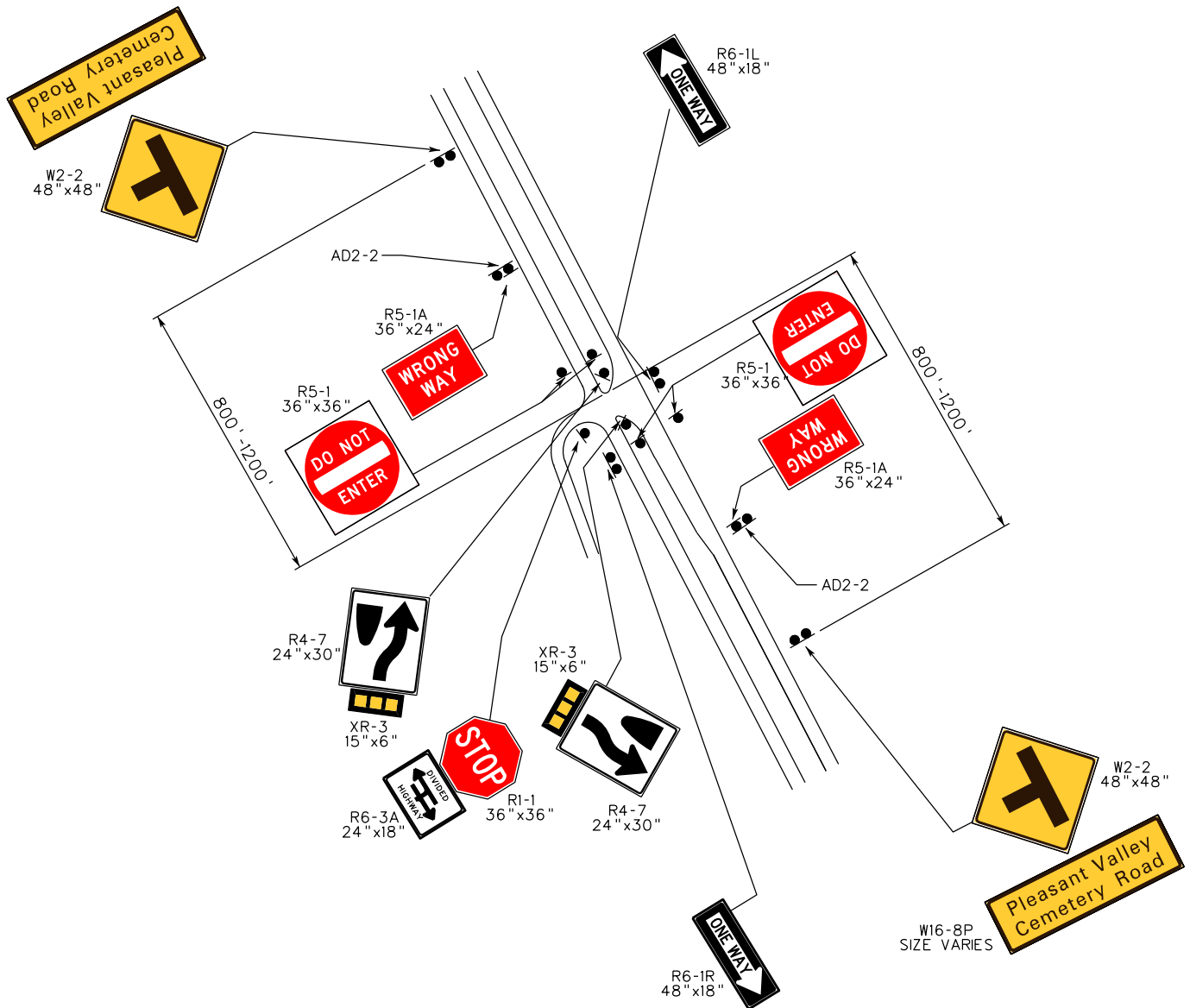

NOTES:

1. AD2-1 OR AD2-2 SHALL BE INSTALLED 100 TO 300 FEET IN ADVANCE FOR NAMED AND NUMBERED COUNTY ROUTES IN ADDITION TO A W2-2 WITHOUT A W16-8P.
2. WHEN THE SIDE ROAD IS A PRIVATE ROAD WITH NO COUNTY ROUTE NUMBER, A W2-2 WITH A W16-8P SHOULD BE INSTALLED AND AD2-2 SHALL NOT BE INSTALLED
3. ALL OTHER SIGNS SHOWN (ONE WAY, KEEP RIGHT, ETC.) SHALL BE LOCATED IN ACCORDANCE WITH FIGURES 4, 5, AND 6.
4. THIS FIGURE IS FOR A SIDE STREET ADT LESS THAN 250.

FIGURE 30
SIGNING FOR A
MINOR INTERSECTION
ON AN EXPRESSWAY
ADT LESS THAN 250

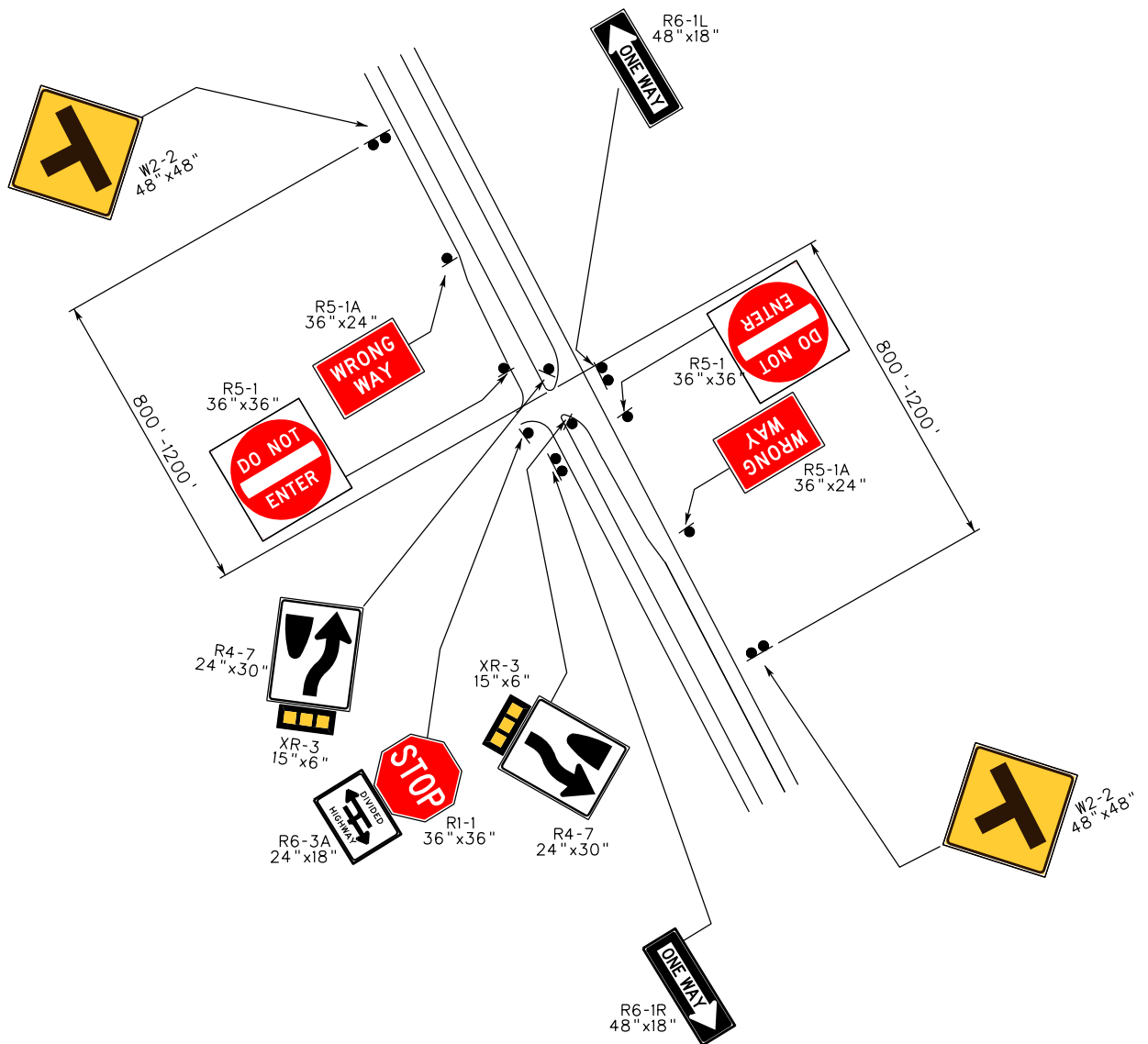

NOTES:

1. INSTALL W2-2 800 TO 1200 FEET FROM INTERSECTION.
2. INSTALL REGULATORY SIGNING IN ACCORDANCE WITH FIGURES 4, 5, AND 6.

FIGURE 31
SIGNING FOR
LAND ACCESS INTERSECTION
ON EXPRESSWAY

2.5.4 Freeway and Expressway Guide Sign Use and Location

2.5.4.1 General Requirements

Unless otherwise stated in this design guide, signs shall be located as required by the Division of Highways' Standard Specifications, Standard Details, and the MUTCD.

Spacing should ideally be 1000' between all major interchange guide signs on the mainline of freeways and expressways. Major interchange guide signs include the 2 MILES, 1 MILE, ½ MILE, and EXIT DIRECTION signs. Where spacing between freeway and expressway interchanges and intersections is limited, a spacing of no less than 600 feet between major guide signs is recommended. On freeways and expressways guide signs shall be at least 300 feet from warning and regulatory signs. Spacing between guide, regulatory, and warning signs on freeway and expressway exit ramps shall be 100 feet minimum. See Figures 22 and 32.

Exit numbers, if appropriate, shall utilize the milepost system and be placed at the top of sign in a Standard Exit panel. The Exit Panel shall be at the extreme right or left depending on whether the exit is to the right or left. If no numbers are used, then the word EXIT shall appear in the last line of the sign as appropriate (Example: EXIT 1 MILE). All major guide signs for lane drops (without an option lane) shall be mounted overhead. Following are descriptions of various guide signs used on freeways and expressways.

2.5.4.2 Two Mile Sign (AE3-2 Major Guide Sign)

At freeway junctions, major interchanges, and intermediate interchanges this sign shall be placed as close as possible at two miles from the exit gore taking into consideration grade, sight distance, slopes, etc. The sign may be moved closer to the exit as needed in one-fourth mile increments.

2.5.4.3 One Mile Sign (AE3-1 Major Guide Sign)

This sign shall be located at all freeway junctions, major, and intermediate interchanges. The sign shall be placed as close as possible to a location one mile in advance of the physical exit gore taking into consideration grade, sight distance, slopes, etc. The sign may be moved closer to or further away from the exit as needed but no more than one-fourth mile. It shall have the same message as the Two Miles sign. If the sign cannot be installed at the one mile location, then the distance legend shall be changed to indicate the correct distance and shall be in one-quarter mile increments. At freeway junction interchanges and in lane drop situations, the One Mile Sign shall be erected on an overhead structure. Where the sign is installed in advance of lane drops at an interchange it shall show the distance to the exit.

SIGN	TITLE	DISTANCE FROM RAMP TERMINAL
A	JUNCTION ASSEMBLY	700' TO 1000'
B	ADVANCE ROUTE TURN ASSEMBLY	500' TO 700'
C	DESTINATION SIGN	200' TO 500'
D	DIRECTIONAL ASSEMBLY	0' TO 50'
E	RAMP ENTRANCE DIRECTION	0' TO 50'
F	CONFIRMING SIGN	200' TO 400'
G	DISTANCE SIGN	300' TO 800'
H	RAMP DIRECTIONAL	200' TO 700'
I	RAMP DIRECTIONAL ASSEMBLY	0' TO 50'
J	FREEWAY ENTRANCE RAMP SIGN ASSEMBLY	0' TO 50'
K	SPEED LIMIT SIGN	300' TO 500'

NOTES

1. THE DISTANCES SHOWN IN THE TABLE SHALL BE APPLIED SO THAT ALL GUIDE SIGNS ARE SEPARATED BY AT LEAST 100 FEET AND PREFERABLY 300 FEET. THIS SPACING ALSO APPLIES TO LOGO RAMP SIGNS ON THE INTERSTATE SYSTEM.
2. ROUTE MARKER ASSEMBLIES SHALL BE MADE UP OF 24"x24" ROUTE SHIELDS, 24"x12" CARDINAL DIRECTIONAL SIGNS (M3-X) AND 21"x15" DIRECTIONAL ARROW AUXILIARY SIGNS (M5-XA OR M6-XA).

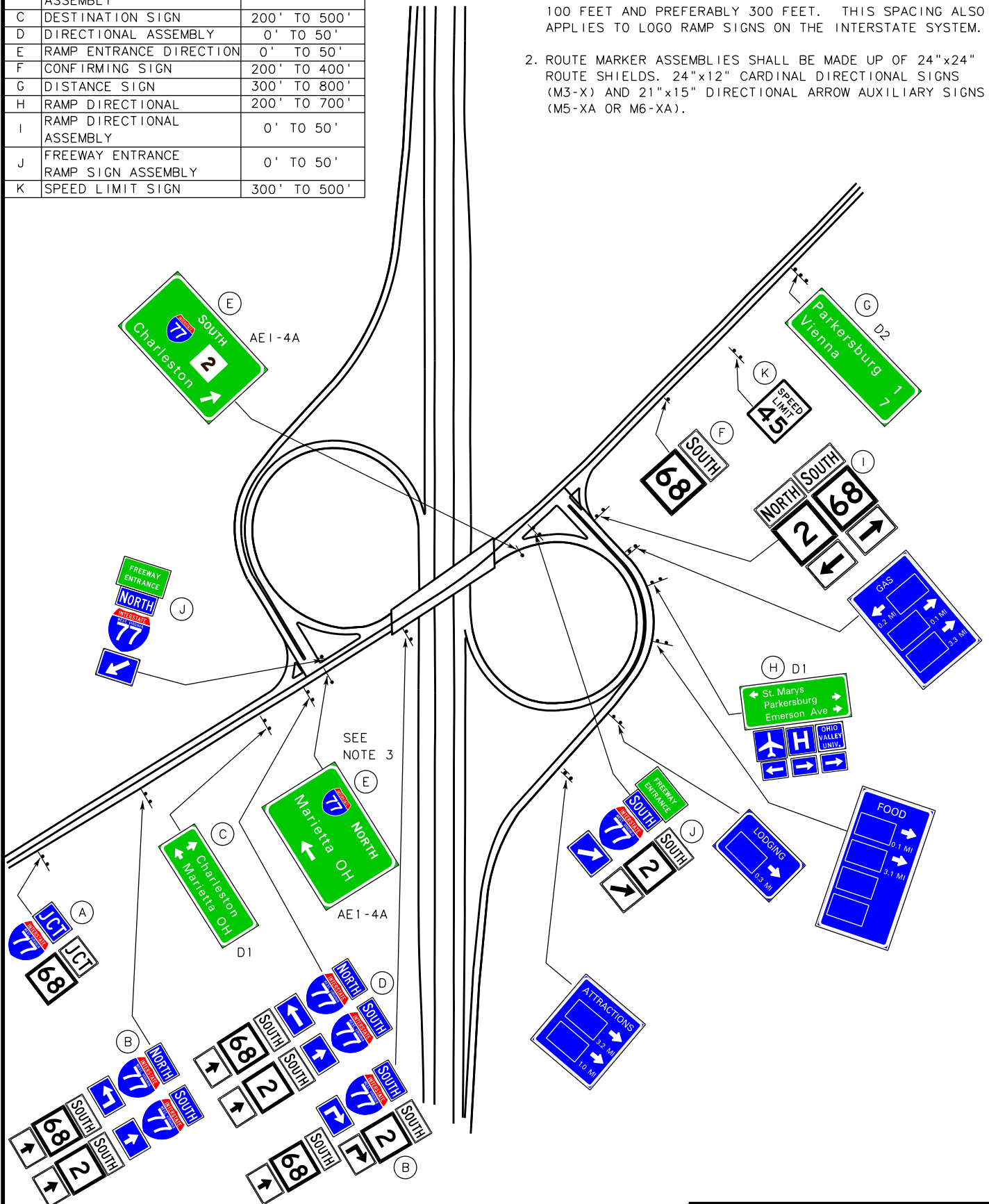

FIGURE 32
GUIDE SIGNING WITHIN A MAJOR OR INTERMEDIATE INTERCHANGE WITH A TWO-LANE CROSSROAD

2.5.4.4 One-Half Mile Sign (AE2-2 Major Guide Sign)

This sign shall be erected as close as possible to a location one-half mile in advance of the physical exit gore at all interchanges taking into consideration grade, sight distance, slopes, etc. The sign may be moved to a location one-fourth mile from the physical exit gore. For freeway junctions and lane drop situations the sign shall be mounted on an overhead structure and should be located 1000 feet to one-quarter mile from the gore.

2.5.4.5 Exit Direction (AE2-1 Major Guide Sign)

This sign shall be erected at all interchanges at the beginning of the deceleration lane as a ground-mounted sign. For lane drops, option lanes, long deceleration lanes exceeding ¼ mile, or whenever conditions warrant its use as outlined in Section 2.5.11 overhead Exit Direction signs should be erected near the theoretical gore and is best positioned over the ramp. It shall have the same message as the One Mile Sign. An overhead Exit Direction sign may be supplemented with a Route Assembly in the gore for freeway junctions. Additionally, for freeway junctions overhead signs usually with down arrows over each lane (AE2-5) shall be installed near the theoretical gore.

2.5.4.6 Exit Gore (E5-1 and E5-1A)

This ground-mounted sign shall be used in all exit gores except at freeway junctions. It shall be located in the gore of the interchange at a point where each edge of the sign is two feet from the paved shoulder as shown on Figures 15 and 26. The Exit Gore sign is a standard sign as shown in the Fabrication Manual, with interchange number if appropriate.

2.5.4.7 Interchange Sequence Sign (AE6-1 Major Guide Sign)

When a town is served by three or more closely-spaced interchanges, this sign may be erected in advance of the first advance guide sign for the first interchange in the series. It shall then be repeated after each interchange until there is only one interchange left. Between the next to the last interchange and the last interchange, a Distance sign (D2-2 or 3) should be erected if space permits. On the interchange sequence sign, the name of the city shall be on the top line followed by the word EXITS, and then the next three interchanges shall be listed in order with distance shown to the nearest one-quarter mile and measured to the physical exit gore. As one interchange is passed, its name will be dropped from the sign and the name of the next interchange in the sequence added, then sequentially until there are only two interchanges left. Ideally, the Interchange Sequence sign should be placed overhead and in the median. Interchange Sequence signs shall be considered as one or more of the required three Major Guide Sign advance notices of the interchange, but every interchange shall have at least one normal advance Major Guide sign. The sign shall have a full border width line the full length of the sign below the first line containing the name of the city. See Figures 25 and 26.

2.5.4.8 Intersection Sequence Sign (AE6-1 Major Guide Sign for Expressways Only)

Sequence signs installed on expressways where the sequence contains only interchanges or a combination of interchanges and at-grade intersections are the same as for Interchange Sequence signs but use smaller legend when ground mounted. All sequence signs on both Freeways and Expressways installed overhead are 13.3 mixed case. Sequence signs on expressways where only at grade intersections are within the entire sequence will contain only the name of the community on the top line with intersecting streets listed below. A solid line 75 percent of the length of the sign and 75 percent of the width of the border shall separate the name of the community from the individual intersecting streets.

2.5.4.9 Next X Exits Sign

Where freeways pass through urban areas served by a succession of several interchanges, a NEXT X EXITS sign may be used. The sign shall be located in advance of the first Advance Guide sign for the first interchange in the sequence.

2.5.4.10 Post Interchange and Intersection Signs

After passing through the interchange area on a freeway or expressway, the driver shall see a Confirming assembly, a Speed Limit sign, a Distance sign, and an EMERGENCY STOPPING ONLY sign in that order. See Figures 26 and 27.

2.5.4.10.1 Confirming Assembly

On freeways and expressways the Confirming Assembly shall consist of a 36 by 36 or 45 by 36 route marker(s) and a 30 by 15 cardinal marker(s). On freeways the Confirming Assembly shall be installed 500 feet past the end of the taper for the acceleration lane. When required on expressways and two lane roads the assembly should be located 100 to 250 feet beyond the intersection. On two lane roadways the Confirming Assembly consists of a 24 by 24 or 30 by 24 route marker and the cardinal markers used with it shall be 24 by 12. Larger Confirming Assemblies may be used if necessary due to wider shoulders or other conditions requiring greater visibility of the sign.

2.5.4.10.2 Speed Limit sign (R2-1)

The R2-1 sign shall be 48 by 60 on freeways and expressways. On freeways and expressways having interchanges the R2-1 sign shall be installed 1500 feet past the end of the taper for the acceleration lane or 1000 feet past the Confirming Assembly. On expressways at major intersections the sign should be erected 300 to 500 feet beyond the crossroad intersection with a US or WV route. On two lane roads the sign should be installed 200 to 350 feet beyond the crossroad intersection with a US or WV route. On two lane roads the sign should be 24 by 30 unless a larger sign is needed for emphasis. Where there are closely-spaced interchanges and/or intersections on freeways and expressways the

R2-1 may be eliminated or located after the last interchange or intersection in the series. See Section 2.2.1 for additional detail regarding R2-1 signs.

2.5.4.10.3 Distance Sign (D2-2, or 3) (Not Major Guide Sign)

The Post Interchange D2 sign shall include the name of the next interchange and the last line shall be the next Control destination if two destinations are displayed on the sign. On freeways and expressways the sign may have a third line of legend that may be another control city or intermediate destination on the same route. The posted distances shall be the distance from the sign location to the approximate center of the city named on the sign, and not to the interchange serving the destination unless it is a road name. If the destination named is further than three miles from the freeway or expressway interchange, the intersecting route number may be used on the sign in lieu of the city name.

The top line of the D2 sign shall always display the closest destination. The D2 sign should be omitted if the distance between interchanges is two miles or less or when sign spacing between interchanges is limited. Distances shall be displayed to the nearest mile. Fractions of a mile will not be allowed. D2 signs are not to be considered Advance Guide or Sequence signs. Post Interchange D2 signs shall be located 2500 feet past the end of the acceleration lane at interchanges or 1000 feet past the R2-1 sign. Control Destinations displayed on D2 signs shall be obtained from Appendix A or Traffic Engineering Directive 220-1 or the latest version. For signing projects on new routes contact Traffic Engineering Division for Control Destinations.

Post Intersection D2 signs on expressways should be erected 500 to 700 feet beyond major intersections, and beyond intermediate intersections where the intersecting roads have an ADT of 1,000 or more vehicles. D2 signs on two lane US and WV routes at intersections with other US and WV routes shall have 6 inch mixed case and be erected 300 to 500 feet beyond the crossroad. In addition to post interchange and post intersection, D2 signs should be erected on expressways leaving incorporated communities and in rural areas on freeways and expressways at distances no greater than five miles. This sign shall normally have two destinations, with a maximum of three destinations, and these destinations shall be of the following combination:

- a. Next Intermediate and next Control destination on the route;
- b. Next two Control destinations if no Intermediate is present;
- c. On overlapping routes, the next Control destination for each route.

2.5.4.10.4 Emergency Stopping Only Sign (R8-7)

This 48 by 36 R8-7 sign shall be installed on freeways approximately 3500 feet past the end of the taper for the acceleration lane (1000 feet past the D2 sign) and shall not infringe on signing for a subsequent interchange and may be eliminated if it does. For closely spaced urban interchanges the

D2 sign or the R8-7 sign may have to be omitted. The D2 sign shall have priority over the R8-7 sign if only one has to be omitted. The R8-7 sign should also be installed on expressways after major intersections. It should also be installed at random intervals as needed, where scenic or other attractions create a tendency for the motorist to stop temporarily, and no turnout or rest area has been provided. One R8-7 sign is recommended between two interchanges if the location does not conflict with other signs. See Section 2.2.2 for additional information regarding R8-7 signs.

2.5.4.11 Other Guide Signs at Interchanges and Intersections on Freeways and Expressways

2.5.4.11.1 Ramp Directional Signs

This sign shall be used on all exit ramps at interchanges. When the intersecting crossroad is a US or WV numbered route, the sign shall be installed on the ramp 200 to 700 feet from the centerline of the crossroad. If the ramp is less than 800 feet in length and the crossroad carries no US or WV route, the sign should be located in a target position opposite the ramp terminus. The legend on this sign shall be limited to three destinations which are consistent with the messages given on the advance guide signs, and/or the control destinations on the intersecting road. If the name of the road was used on the freeway or expressway, then the sign should show that name with a double-headed arrow beneath it and then be located in a target position opposite the ramp terminus. See Figures 22 and 32.

2.5.4.11.2 Junction Guide Sign (AD5-5)

This sign is to be used on an expressway in advance of major intersections with US and WV numbered routes. It is also used on multi-lane conventional road approaches to an interchange. The Junction Guide sign should be located three-fourths of a mile in advance of major intersections and display the legend JCT, ROUTE SIGN, and 3/4 MILE. When spacing of intersections is less than three-fourth mile, this sign may be changed to a one-half mile message and location. When used on a single lane approach to an interchange a Junction assembly consisting of a Junction auxiliary sign and a route sign shall be used.

2.5.4.11.3 Advance Directional Assembly

This assembly is installed on the expressway 1,000 to 1,500 feet in advance of major intersections with US or WV numbered routes. It shall consist of a route marker (36 by 36 or 36 by 45 for three digits), cardinal direction auxiliary sign (30 by 15), and appropriate directional arrow auxiliary sign (21 by 28). It shall show the appropriate directions that the intersecting route takes with separate cardinal direction auxiliary sign, route marker, and directional arrow auxiliary sign for each cardinal direction. Double-headed arrows will not be allowed. Ordinarily, only the intersecting route should be shown on the Advance Directional Assembly. However, if two or more routes overlap and one of the routes

turns off at the intersection, then the Advance Directional Assembly shall show all route numbers and cardinal directions with arrows indicating which routes leave, continue on, or join the highway. The Advance Directional Assembly may also be used on crossroad approaches to interchanges. This assembly is not to be used on exit ramps. The sizes of signs used on multilane crossroads at interchanges shall be the same as those discussed above. See Figure 27.

2.5.4.11.4 Destination Sign (D1-2 or 3)

This sign shall be installed on expressways 700 to 1,000 feet in advance of intersections with US or WV numbered routes. It shall show the control destinations for the various routes with the top line displaying the straight ahead control destination, the second line displaying the control destination to the left and the third line displaying the control destination to the right. A maximum of three control destinations may be shown. Distances to the destinations shall not be displayed. This sign is also to be used on crossroads on the approach to an interchange. On crossroads at interchanges the D1-2 or 3 sign should be located 300 to 800 feet past the ramp. Control destinations can be found in Appendix A and in the latest version of Traffic Engineering Directive 220-1. See Figure 27.

2.5.4.11.5 Final Directional Assembly

This assembly should be installed on the expressway within 200 feet of the intersection. When there is a left-turn lane more than 200 feet in length which has to be used by one of the routes, the Final Directional Assembly shall be erected at the beginning of the taper for the left-turn lane and a second Directional Assembly showing only the route turning to the right should be erected within 100 feet of the intersection. The Final Directional Assembly shall have the same size signs and repeat whatever is shown in the Advance Directional Assembly with the directional arrows appropriately changed to indicate the direction of the turns. This assembly is also to be used on single lane crossroad approaches to interchanges. See Figures 27 and 28.

2.5.4.11.6 Advance Intersection Sign (AD1-2)

This sign should be installed at intermediate intersections that are located at least 1/4 mile or more from another intersection. This sign shall be located 800 to 1,200 feet from the centerline of the crossroad. The road name and County Route Number shall be the first line of copy and the second line shall be the appropriate direction (NEXT RIGHT or NEXT LEFT). If two different road names occur at the intersection, the sign shall be as follows: (1) road name and number to the left, (2) NEXT LEFT, (3) road name and number to the right and (4) NEXT RIGHT. When two different road names are displayed, a horizontal line running the entire width of the sign shall separate the two messages. If the road name is the same on both approaches to the intersection, the second line of copy shall be 1/4 MILE and the location shall be changed accordingly. See Figures 28 and 29.

2.5.4.11.7 Intersection Direction Sign (AD2-2)

This sign shall be erected at all intermediate and minor intersections as previously defined. This sign should ideally be located near the beginning of the left turn lane or alternatively 100 to 300 feet from the centerline of the cross road. It shall show the applicable road names and County Route Numbers of the intersecting roads and be consistent with the Advance Intersection sign, if present. It shall have arrows on it to indicate proper directions, and if the intersecting road goes in both directions, a double-headed arrow will be placed below the name and number. The name of the road to the left shall always be displayed above the name of the road to the right. See Figures 28 and 29.

2.5.4.11.8 Freeway Entrance Ramp Sign Assembly (M8-1)

A Freeway Entrance Ramp Sign Assembly consisting of a FREEWAY ENTRANCE (M8-1), Cardinal Marker, Route Sign, and 45 degree down arrow shall be installed within 50 feet of each freeway ramp entrance in each direction of travel. For ramps intersecting on the right the sign assembly shall be mounted on the far right of the approach. For ramps intersecting on the left the sign assembly shall be mounted on the far left. The M8-1 shall be 36 by 21, the cardinal markers 30 by 15, the route shield 36 by 36 (or 36 by 45 for three digit routes), and the 45 degree down arrow 28 by 21. If the ramp entrance is the stem of a T intersection approach, a left or right arrow shall be used instead of the 45 degree down arrow. See Figures 22 and 32 to determine whether the 45 degree arrow should be pointed up or down.

2.5.5 Supplemental Guide Signs on Freeways and Expressways

2.5.5.1 Supplemental Destinations

Destinations that are accessible from an interchange or intersection, other than places shown on the standard guide signing, may be shown on a Supplemental Guide Sign. If used on freeways within the sequence of signs approaching an interchange, the Supplemental Guide Sign (AE5-1) shall list one or two destinations with the appropriate EXIT panel indicating the exit number for the interchange. Only one Supplemental Guide Sign shall be installed on freeways within the sequence of interchange approach signing. One additional Supplemental Guide Sign may be installed on freeways not in the sequence of interchange approach signing and preferably at least one mile in advance of the first guide sign. If installed the second Supplemental Guide Sign (AE6-1) shall contain the name of the supplemental destination with the legend USE EXIT X because it is installed outside the approach signing for the interchange.

On expressways if the destination is at an intersection, the Supplemental Guide Sign (AE5-1) should contain the legend NEXT RIGHT/LEFT, NEXT INTERSECTION or other action message as appropriate. On the approach to interchanges the sign shall be installed 800 to 1,000 feet beyond the One-half Mile sign or TODS/LOGO sign. At expressway intersections it shall be installed 1,000 feet in advance of the Advance Intersection sign, or if there are no Advance Intersection signs it shall be installed 1000 feet in advance of the Intersection Direction Sign or Destination Sign. Figure 26 has an example of supplemental guide signing

on a freeway and Figure 27 has an example of supplemental guide signing on an expressway.

2.5.5.2 Traffic Generators

Various traffic generators may be signed on both freeways and expressways. One of these is a State Police Detachment. On Freeways one 30 by 30 D9-15 STATE POLICE sign should be installed underneath the 1 MILE Advance Guide sign for the interchange, one under the Exit Direction sign, and one 24 by 24 D9-15 sign with an arrow should be installed underneath the Ramp Directional sign on the exit ramp. On expressways one 30 by 30 D9-15 STATE POLICE sign with an advance turn arrow should be installed underneath the Advance Intersection sign and one 24 by 24 D9-15 sign with a left or right arrow should be installed underneath the Intersection Direction sign.

Hospital signing on a freeway shall consist of a 30 by 30 D9-2 mounted underneath the One Mile Advance Guide sign and underneath the Exit Direction sign. The D9-2 shall be mounted on the left sign support. A D9-2 with an arrow (M6-XA) shall also be installed on the exit ramp. Follow-through signing must also be installed on the local road system to lead unfamiliar motorists to the hospital. On expressways one 30 by 30 D9-2 shall be mounted underneath the Advance Intersection sign, and a 24 by 24 D9-2 with an arrow (M6-XA) shall be mounted underneath the Intersection Direction sign. Follow-through signing shall also be installed.

The signing would be similar for other traffic generators such as a regional jail. Signing would also be similar for service signs installed underneath the Advance Intersection sign. See Figures 26, 27, 28 and 29.

2.5.6 Rest Area and West Virginia Welcome Center Signing (D5-1, D5-1A, D5-1B, D5-2, and D5-6)

REST AREA/WEST VIRGINIA WELCOME CENTER signs shall be installed for the first rest area when entering the state on freeways. In order to qualify for signing the rest area must ordinarily be within one-half mile of the freeway. The signing sequence for rest areas shall be similar to that used for interchanges. Two advance notices should consist of a REST AREA 2 MILES (D5-1A) and REST AREA 1 MILE (D5-1). A REST AREA 1 MILE and REST AREA ½ MILE may be used instead as the two required advance notices. A REST AREA NEXT RIGHT (D5-1B) sign placed as an exit direction sign shall also be provided. A gore sign stating REST AREA with an arrow (D5-2) shall also be erected. For West Virginia Welcome Centers the advance signs shall have the legend REST AREA WEST VIRGINIA WELCOME CENTER. If advance signs must be installed in Border States, their installation must be coordinated with Department of Transportation personnel in the respective border state. See Figure 33 for WEST VIRGINIA WELCOME CENTER signing on the freeway and Figure 34 for REST AREA signing. Typical signing within the rest area is shown on Figure 35.

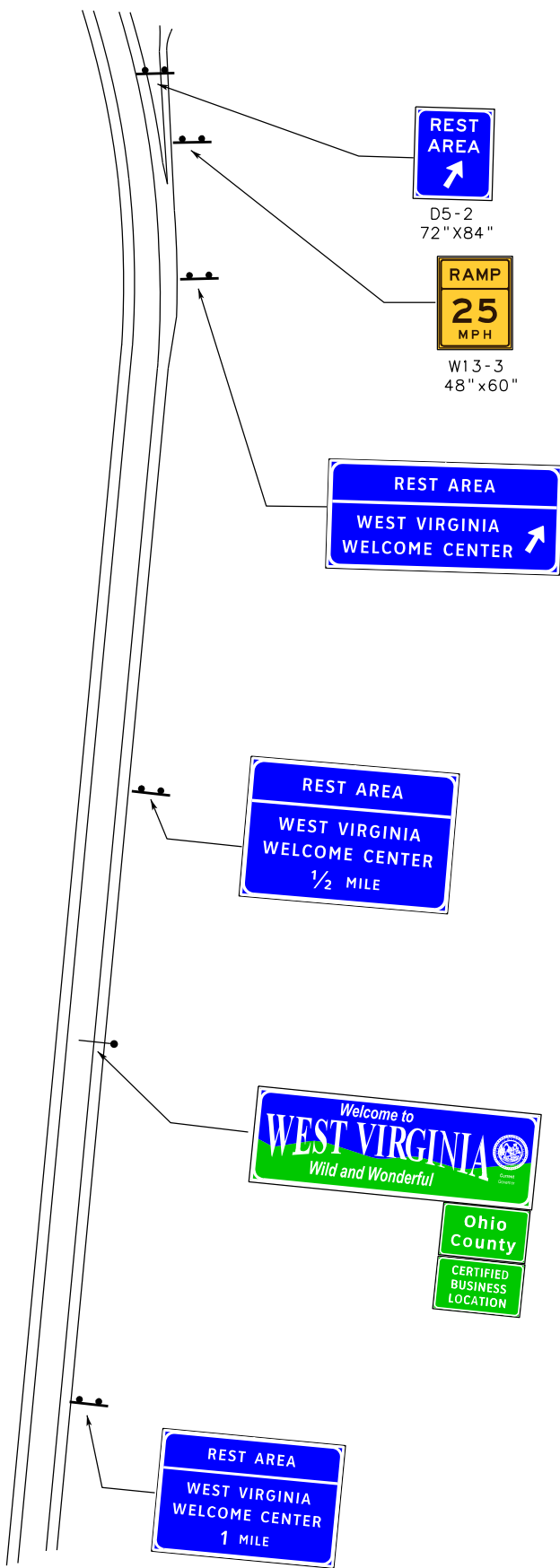

FIGURE 33
WELCOME CENTER
REST AREA SIGNING
ON A FREEWAY

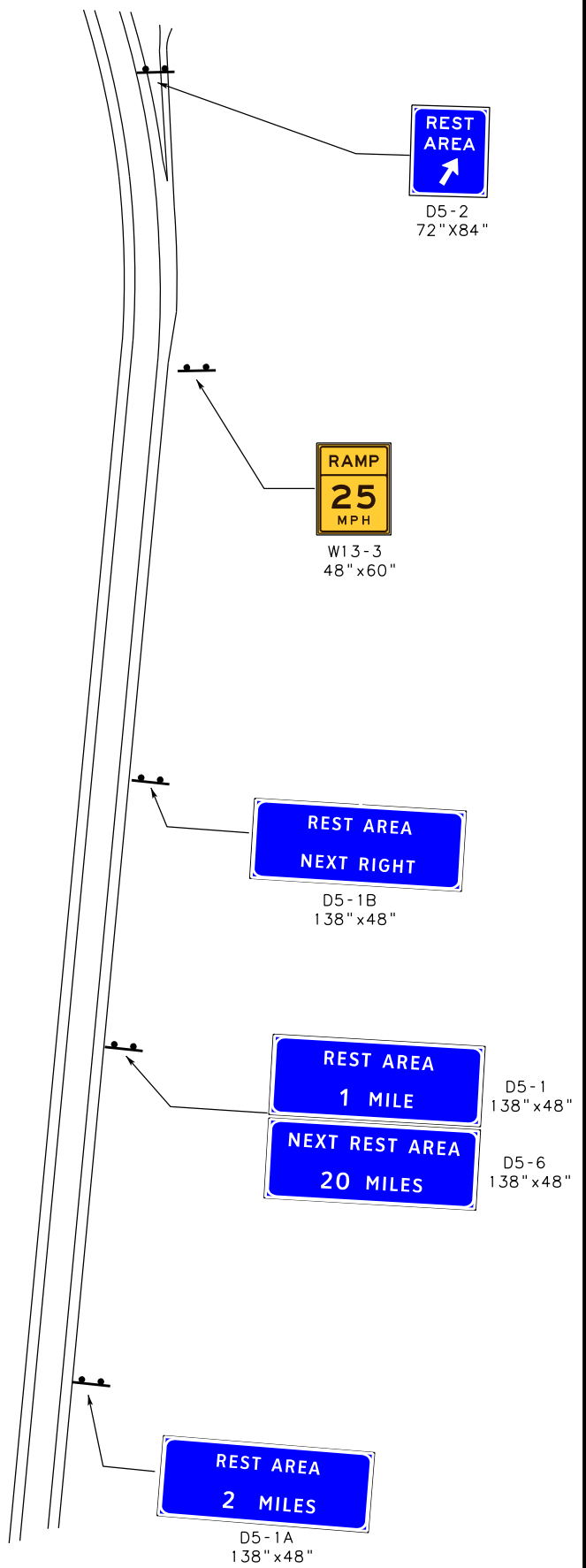

FIGURE 34
REST AREA SIGNING
ON A FREEWAY

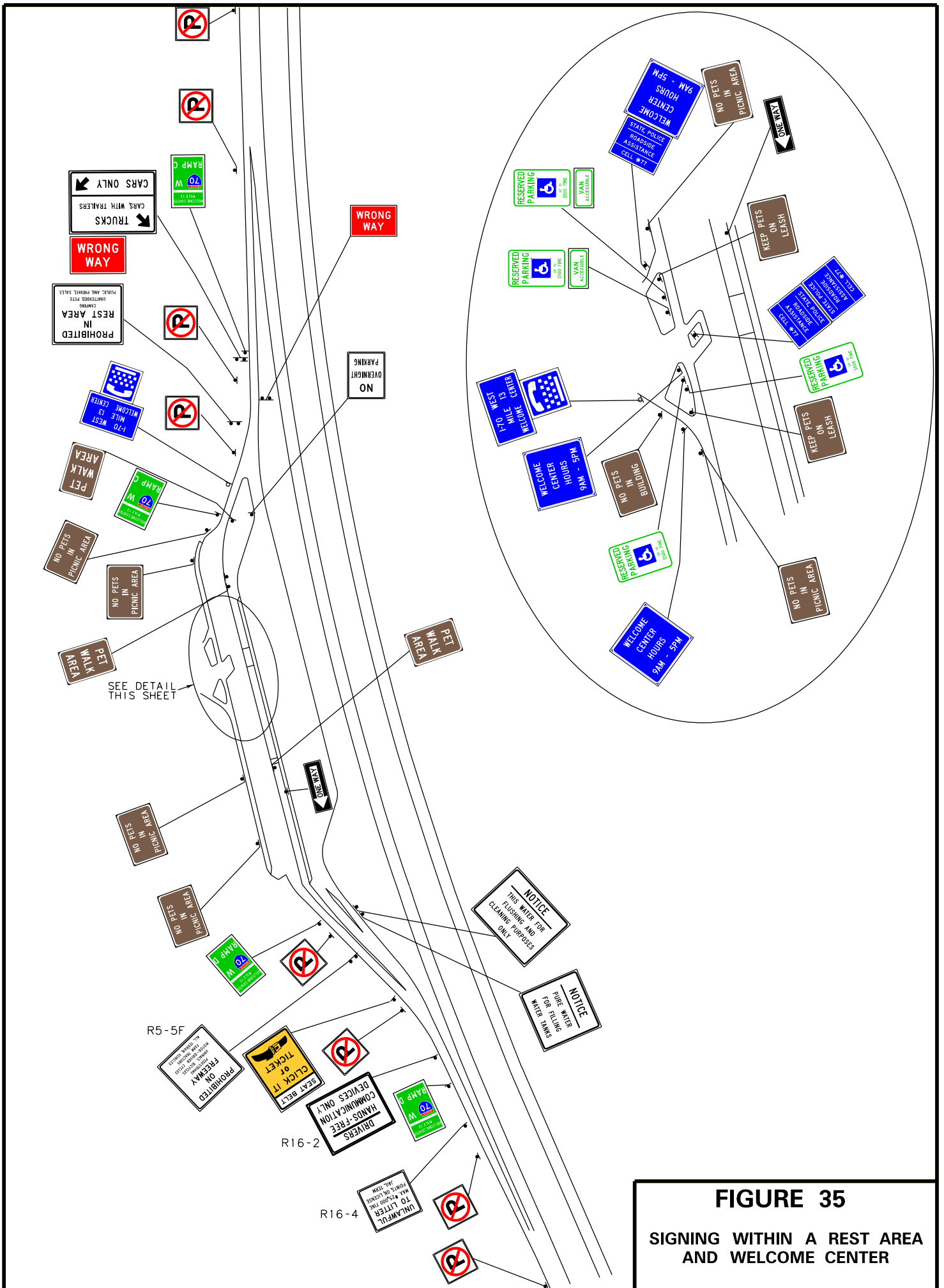

FIGURE 35
SIGNING WITHIN A REST AREA
AND WELCOME CENTER

A sign with the word message NEXT REST AREA XX MILES (D5-6) may be installed as a supplemental panel mounted below the first or second advance rest area guide sign. Where the rest area is open but there are no facilities available, a sign with the word message NO FACILITIES may be installed as a supplemental panel mounted below the advance rest area guide sign. Rest Area signing shall not be installed for a parking area or other areas having no toilet facilities. Instead it should be signed as a PARKING AREA, SCENIC AREA, SCENIC VIEW, SCENIC OVERLOOK, TRUCK PARKING, etc.

2.5.7 Weigh Station Signing (D8-1, D8-2, D8-3, and R13-1)

The signing sequence on a freeway shall include a WEIGH STATION 1 MILE (D8-1) advance sign, WEIGH STATION ½ MILE (D8-1A), WEIGH STATION NEXT RIGHT (D8-2 which serves as an exit direction sign), and a WEIGH STATION with arrow gore sign (D8-3). All of the signs shall have white legend and border on a green background. A Regulatory Sign stating ALL TRUCKS COMMERCIAL VEHICLES NEXT RIGHT WHEN FLASHING (R13-1) may be installed approximately three-fourth mile from the weigh station gore sign. See Figure 36 for signing on the freeway and Figure 37 for signing within the weigh station.

2.5.8 Runaway Truck Ramp Signing (W7-4, W7-4A, W7-4B, and W7-1B)

Two advance signs shall be installed for all Runaway Truck Ramps on freeways. The first one shall be installed at one to two miles in advance with the message RUNAWAY TRUCK RAMP X MILES (W7-4). The second sign should be installed one-half mile from the runaway truck ramp and have the message RUNAWAY TRUCK RAMP 1/2 MILE (W7-4). An Exit Direction sign shall be installed at the beginning of the deceleration lane and have the message RUNAWAY TRUCK RAMP with an upward sloping right arrow (W7-4B). A sign shall be installed in the gore with the message RUNAWAY TRUCK RAMP with an upward sloping right arrow (W7-4A). Ordinarily, TRUCK ESCAPE RAMP signs are installed in conjunction with HILL signing (W7-1B as discussed in Section 2.3.5.6). Red delineators shall be used along the deceleration lane and both sides of the ramp and 3 NO PARKING (R8-3A) signs shall be installed along the deceleration lane. See Figure 38.

2.5.9 Guide Signing for Toll Facilities (M4-14)

Toll highways are typically limited-access freeway or expressway facilities. TOLL Auxiliary Sign (M4-14) shall have a black legend and border on a yellow background and shall be mounted directly above the route sign or, if used, above the cardinal direction sign. All green and white guide signs for toll facilities shall contain a Toll plaque containing the legend TOLL ROAD in black legend on a yellow background. The plaque shall be mounted beneath the guide sign.

NOTES:

1. ALL SIGNS SHOULD BE SPACED 800 TO 1000 FEET.

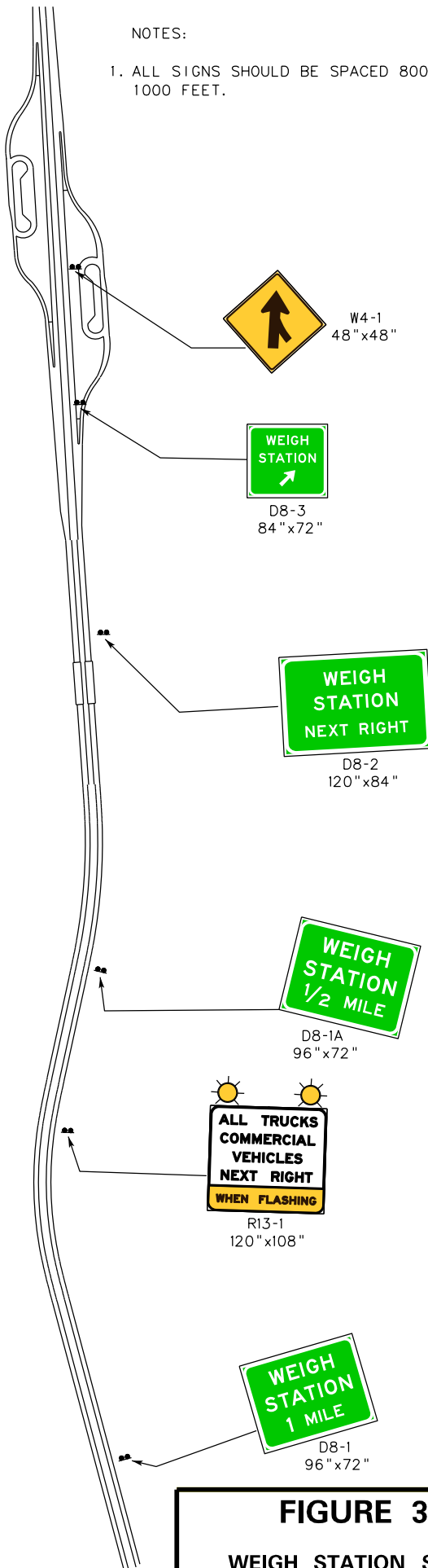

FIGURE 36

WEIGH STATION SIGNING ON A FREEWAY

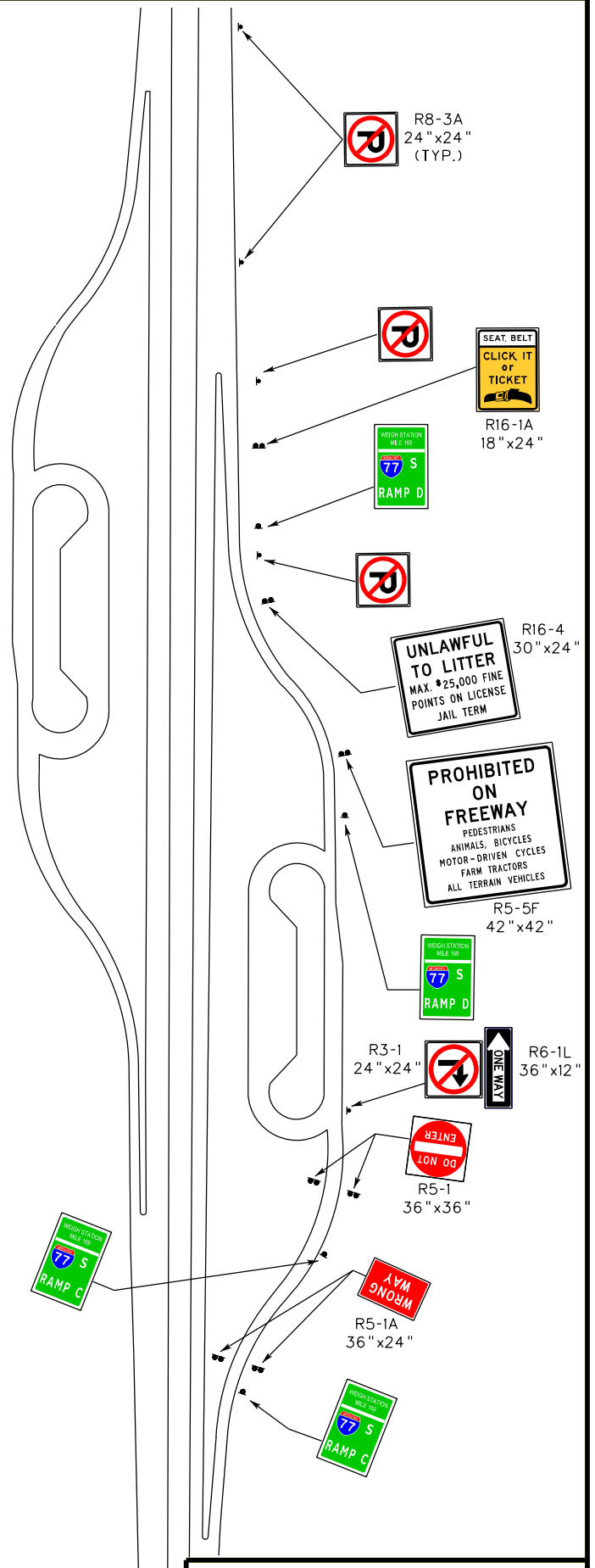

FIGURE 37

SIGNING WITHIN A WEIGH STATION

NOTES:

1. INSTALL RED DELINEATORS AT 100 FT SPACING ALONG THE DECELERATION LANE AND RAMP.
2. INSTALL 3 R8-3A SIGNS ALONG THE DECELERATION LANE.

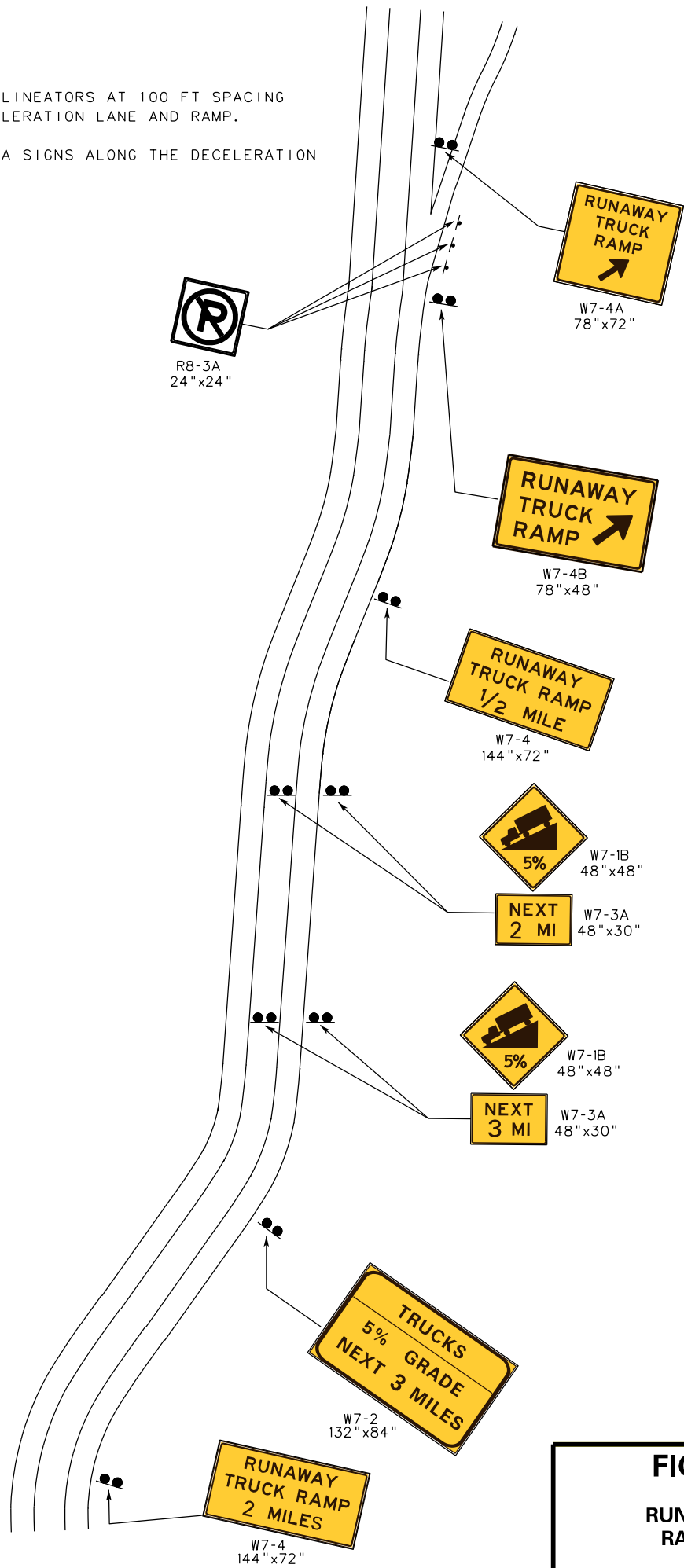

FIGURE 38

RUNAWAY TRUCK RAMP SIGNING

2.5.10 Interchange Exit Numbering and Reference Location Signs (D10C, D10F, D10-1FR, and D10-1CR)

All Interstate highway interchanges shall have exit numbers assigned to them based on the reference location sign exit numbering method in the MUTCD (Section 2E.31). Enhanced Reference Location Signs (D10F on Interstate Highways and D10C on Expressways) shall be installed every one-half mile in rural areas and two-tenths of a mile in urban areas on both freeways and expressways. On freeways and expressways the signs shall be installed every two-tenths mile within 1000 feet of an urban interchange area. The interchange area is defined as the area encompassed by the beginning of the deceleration taper to the end of the acceleration taper in either direction.

Enhanced Reference Location signs within an interchange area shall be installed not less than two-tenths of a mile apart. On the mainline signs shall be installed back to back on the median barrier where present and the median width is 12 feet or less from edge line to edge line. A minimum of two 12 by 18 Ramp Reference Markers (D10-1FR on freeway ramps and D10-1CR on Expressway ramps) shall be installed on each entrance and exit ramp on freeways and expressways. This also applies to ramps serving welcome centers, rest areas, and weigh stations. The spacing of the signs is determined by ramp length and shall be no more than 500 feet apart. Additional signs should be installed for longer ramps. On entrance ramps the first sign should be installed 100 feet from the cross road and the last one should be at or near the physical gore. On exit ramps the first sign should be installed across from the exit gore sign and the last one should be within 100 feet of the cross road. Ramp Reference Markers shall not interfere with or overlap the mainline and vice versa.

All Reference Location signs shall be installed at a mounting height of five feet to the bottom of the sign and the location shall not interfere with other signs nor shall they be mounted on other sign assembly supports. If an adequate location no more than 100 feet from the proper location can be found, in urban areas the mainline Reference Location sign may be eliminated.

2.5.11 Overhead Sign Installations

Overhead signs should be used on freeways and expressways at locations where lane-use control is desirable or where it is necessary to emphasize the sign message. Overhead signs may be used on other roadways where space is not available along the right of way. Either cantilever or full span overhead signs may be used, depending upon the number of signs, amount of legend to be displayed, the distance from the center of the upright to the center of the sign(s) and the size limitations of the structure. Ordinarily, a cantilever sign should be considered when the structure will contain only one sign, or two similar signs mounted back to back, and the combination of the sign area and distance from the center of the upright to the center of the sign does not exceed size limitations of the structure. Care shall be taken not to overload the sign(s) on any structure with too much information so that the road user has adequate time to make the proper response in both day and night conditions. No more than three signs shall be installed on any overhead structure in one direction. Care should be taken to insure the load carrying capacity of the structure is not exceeded. The following factors shall be

considered when determining whether to install overhead signing at any location:

1. Traffic volume at or near capacity
2. Complex interchange design
3. Three or more lanes in each direction
4. Restricted sight distance
5. Closely spaced interchanges
6. Multilane exit ramps or roadways with option lanes
7. Large percentage of trucks
8. Background of street lighting or outdoor advertising signs
9. To maintain consistency of sign message locations throughout a series of interchanges.
10. Insufficient lateral clearance for ground-mounted signs
11. Freeway junctions/splits
12. Lane drops
13. Left hand exit ramps
14. Lane control
15. Pull-through signs
16. Lane ends
17. Two way left turn lanes on five lane highways
18. High speed traffic

2.5.12 Left Exit Panels (E1-5A, E1-5B, E1-5C, and E1-5P)

For numbered exits to the left on freeways, a 48 by 18 black on yellow without border LEFT plaque (E1-5P) shall be added to the top left-hand edge of the EXIT PANEL (E1-5A,B, or C) centered horizontally and vertically above the word EXIT. See Figure 25. For LEFT EXIT destinations included on Sequence Signs use a LEFT EXIT (90 by 16 black on yellow with no border) to the right of the destination. For left exits at interchanges without an Exit number, use 6 feet by 2.5 feet black on yellow LEFT at the top left of the Advance Guide and Exit Direction signs.

2.5.13 Interchange Lane Drop Signing

A dropped lane is a through lane that becomes a mandatory exit lane on a freeway or expressway. Lane drops are critical decision points that require overhead signs to clearly indicate which lane to enter to reach a destination. Overhead guide signs shall be used for the 1 Mile, 1/2 Mile, and Exit Direction signs. Where there is no option lane the EXIT ONLY portion of the sign shall contain the words EXIT ONLY with a down arrow centered over the lane and between the words. Where two lanes exit with the center lane being an option lane, the Exit Direction sign shall contain the words EXIT ONLY with two upward sloping arrows. See Figures 25, 39, and 40.

NOTES:

1. GUIDE SIGNS SHOULD BE 600' TO 1000' APART.
2. THIS FIGURE SHOWS A SINGLE LANE BEING DROPPED AS AN EXIT ONLY LANE AND THE RIGHT THROUGH LANE IS AN OPTIONAL EXIT LANE.

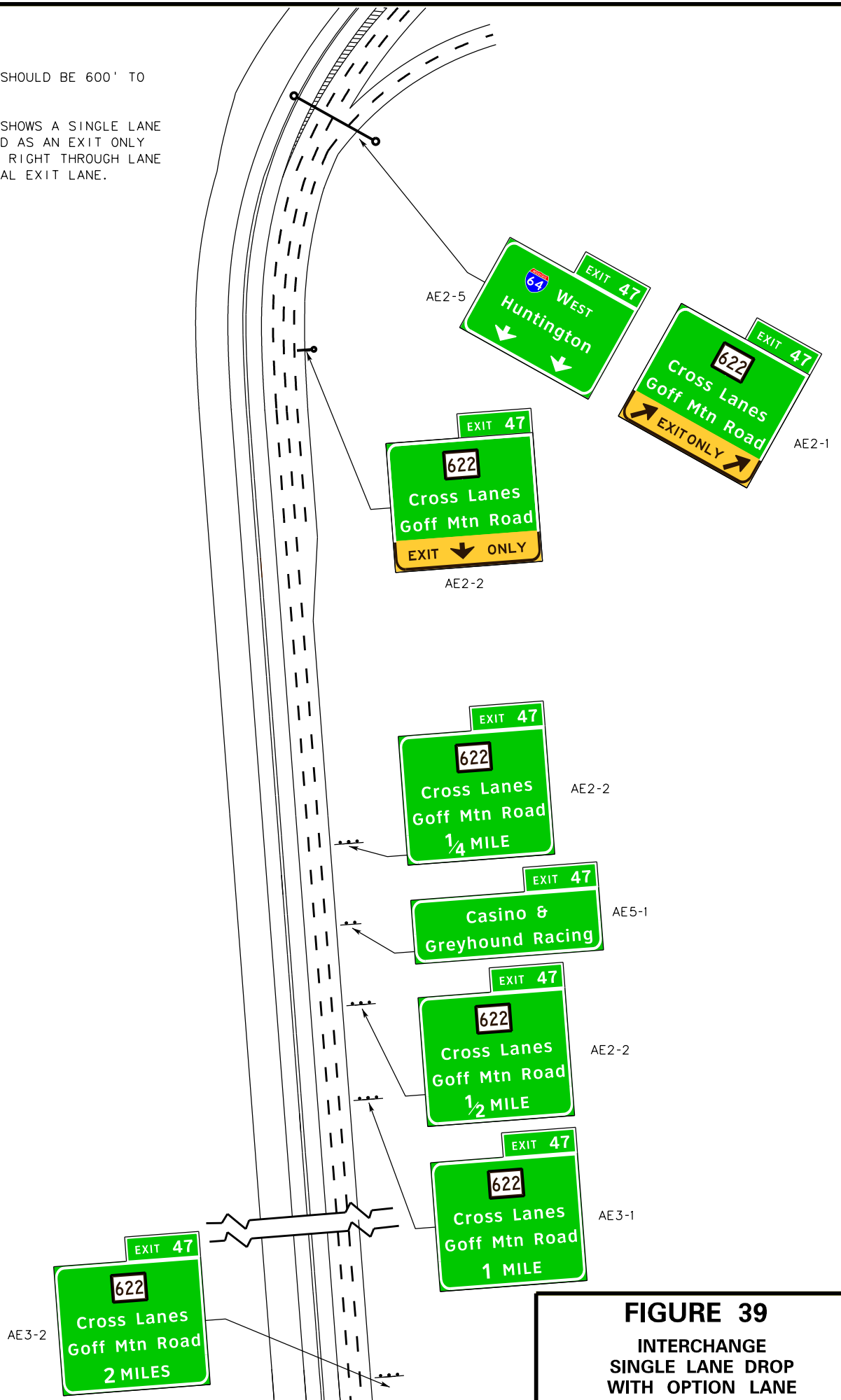

FIGURE 39
INTERCHANGE
SINGLE LANE DROP
WITH OPTION LANE

NOTE:

THIS FIGURE SHOWS A SINGLE LANE BEING DROPPED AS AN EXIT ONLY LANE AT A FREEWAY INTERCHANGE.

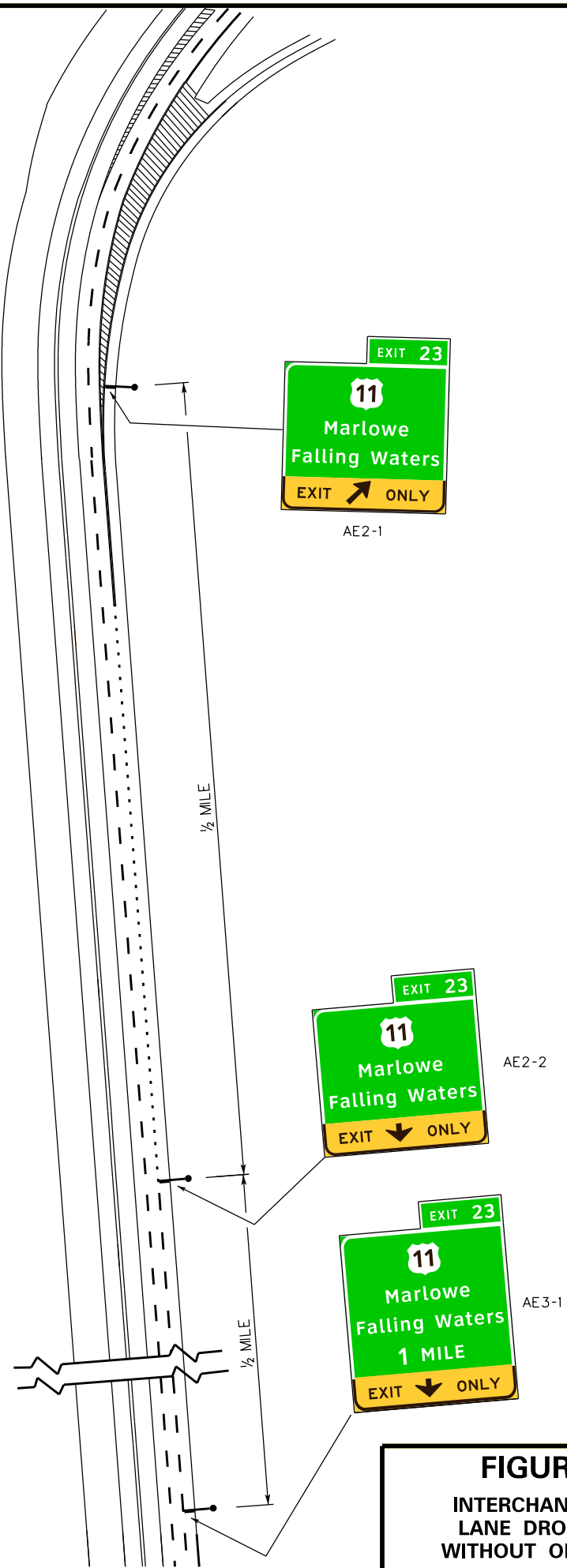

FIGURE 40
INTERCHANGE SINGLE
LANE DROP SIGNING
WITHOUT OPTION LANE

2.5.14 Boundary Line Signs

2.5.14.1 State Line Signs (I2 and I2A)

On freeways and expressways the State Line (I2 or I2A) and County Line (I27) signs as appropriate shall be installed as close as possible to the actual West Virginia or County Line. The I2 is a 6 feet by 2 feet WELCOME TO WEST VIRGINIA Wild and Wonderful sign that is ground-mounted on two lane US and WV Routes entering the state. The I2 is also ground-mounted in Welcome Centers and Rest Areas. The I2A is a 12 feet by 6 feet sign or 24.5 feet by 8 feet (when mounted overhead) that is installed at State Lines. Where the highway enters West Virginia the I2 shall be installed only on the inbound side of the route located at or very near the State line. When an overhead sign structure is used to support the state line sign, the I27 sign may be installed on the upright of the support. The I27 sign shall have a white legend on a green background. I27 with CERTIFIED BUSINESS LOCATION (I27A) signs underneath shall be installed on every entrance to the state on all Interstate, US, and WV numbered routes.

The typical signing sequence at State Lines is as follows in the direction of travel: I2 or I2A SIGN, I27 SIGN, CERTIFIED BUSINESS LOCATION (I27A) (where applicable mounted underneath the I27), CONFIRMATION sign WITH EISENHOWER INTERSTATE SYSTEM (M1-10) mounted underneath, SPEED LIMIT (R2-1) with RADAR ENFORCED (R2-8 mounted underneath), CLICK IT OR TICKET (R16-1A), CRASH NOTICE (R20-3), EMERGENCY STOPPING ONLY (R8-7), STATE POLICE ROADSIDE ASSISTANCE *77 (D13-1), STATE LAW MOVE OVER FOR STOPPED EMERGENCY VEHICLES (R20-4), DRIVERS/HANDS-FREE COMMUNICATION DEVICES ONLY (R16-2), 511 TRAFFIC INFO CALL 511 (D12-5), and UNLAWFUL TO LITTER (R16-4).

At County Lines the R20-3 and R20-4 signs may be omitted. These signs should be installed within one to two miles of the state line at every entrance into the state and at appropriate intervals in each direction on both freeways and expressways. They should be installed primarily in rural areas and not in the sequence of guide signing approaching an interchange or intersection. The R20-4 should be repeated every 20 to 25 miles on freeways and expressways. A 102 by 60 D13-2 sign shall be installed only at the state line and the smaller 72 by 60 D13-1 sign should be installed every 10 to 15 miles on freeways and expressways. An 18 by 18 D13-1 shall also be installed in rest areas. A R16-2 sign 78 by 60 shall be installed on freeways and a smaller 54 by 36 shall be installed on expressways.

SEAT BELT CLICK IT OR TICKET (R16-1A) signs shall be installed at the WV Line on all roadways entering the state and a smaller 18 by 24 on entrance ramps from rest areas. The R16-1A signs shall not be repeated at other locations on the mainline of Interstate Highways. See Figure 41 for typical miscellaneous signing installed on freeways at state lines.

NOTES:

1. MAINTAIN A MINIMUM OF 500' FROM ANY GUIDE SIGN.
2. MAINTAIN A MINIMUM OF 400' BETWEEN ANY OF THESE SIGNS.
3. THE 1-27 AND 1-27A MAY BE ATTACHED TO THE UPRIGHT SUPPORT OF THE OVERHEAD SIGN.

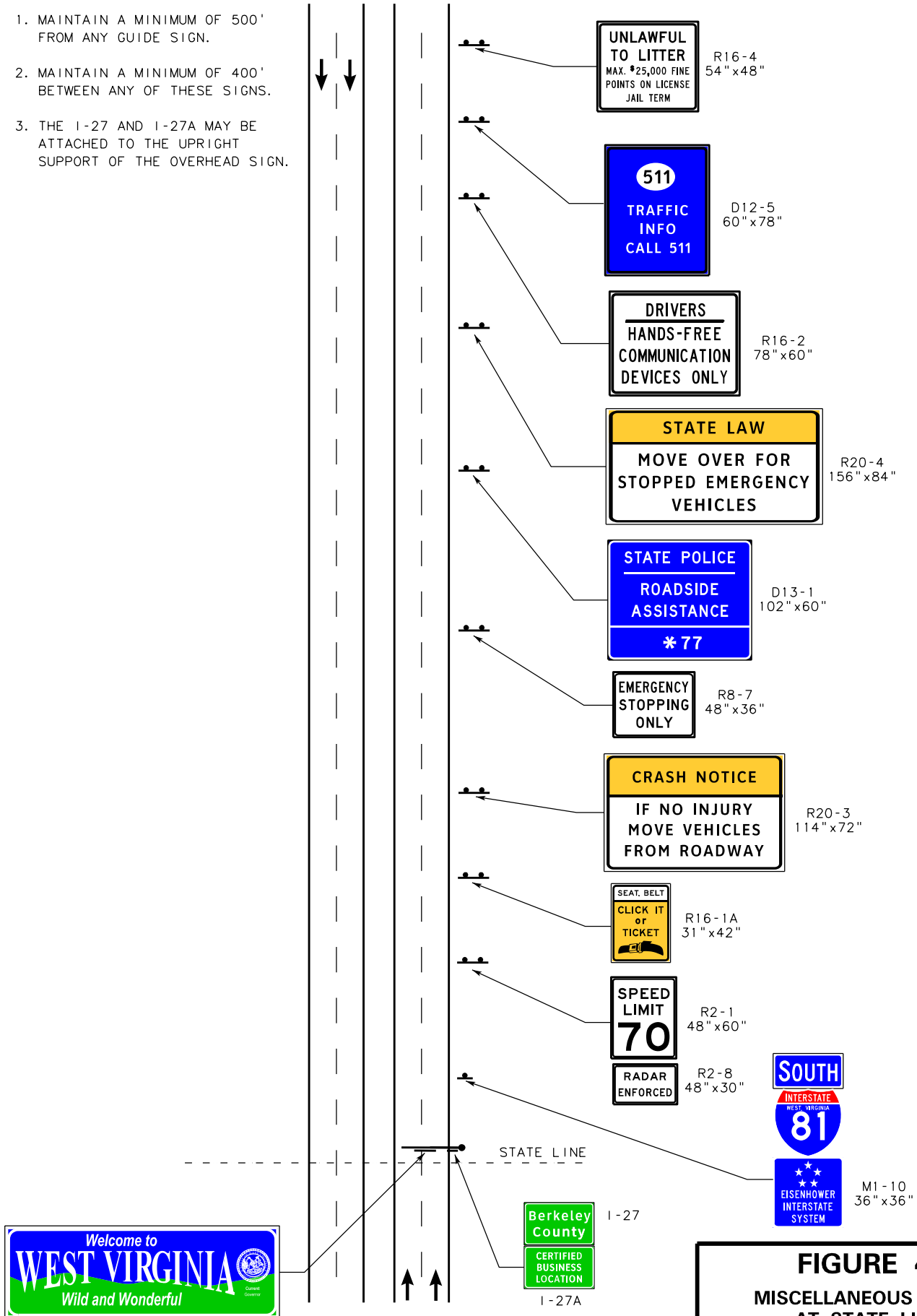

FIGURE 41
MISCELLANEOUS SIGNS
AT STATE LINE
ON FREEWAYS

2.5.14.2 County Line Signs (I27 and I27A)

Where freeways or expressways cross county lines within the state, one I27 signs with I27A mounted underneath shall be installed at a right angle to the roadway on the right side facing traffic. The signs facing opposite directions of traffic shall be directly across from one another. CERTIFIED BUSINESS LOCATION (I27A) signs (if applicable) shall be installed underneath the I27. I27 and I27A signs shall be installed on every entrance to the state or crossings of county lines on all Interstate, US, and WV numbered routes. Both the I27 and I27A signs may also be installed on County Routes having an ADT of 400 or more. When used on County Routes 4 inch mixed case legend shall be used on the I27 and 4 inch E legend shall be used on the I27A. The typical signing sequence on freeways and expressways at County Lines is as follows in the direction of travel: I27 SIGN, I27A mounted underneath the I27, and SPEED LIMIT (R2-1) with RADAR ENFORCED (R2-8 mounted underneath). See Figure 42.

2.5.14.3 City Limit Sign (I-40)

On freeways and expressways only signs with the legend CITY LIMIT (I-40) may be installed where the Corporate Line crosses the route. The sign should be installed within one hundred feet of the actual boundary in a location that does not interfere with other signs. The sign should be installed at a mounting height of five feet to the bottom of the sign. The location of the Corporate Line can be obtained from the respective city or town, or from Traffic Engineering Division.

2.5.14.4 City or Town Name Sign (I-25)

On non-expressways I-25 signs should be placed on all US and WV numbered routes on the right side of the road as close as possible to the Corporate Line. The sign may also be installed on county roads having an ADT of at least 500. The sign is to be installed only when the Corporate Line crosses both sides of the highway. If the Corporate Line crosses only one side of the highway, then I-40 signs shall not be installed.

2.5.14.5 Unincorporated Community Name Sign (I-26)

Signs for unincorporated communities shall not be installed on freeways or expressways. Unincorporated community signs may be installed on any non-expressway or non-freeway in accordance with the current version of Traffic Engineering Directive 202.

2.5.14.6 Multiple Boundaries

Where a combination of state line, county line, etc. exists at one location, the signs should be separated by minimum distances of 400 feet on freeways and expressways and 200 feet for two lane highways. The signs shall be installed in the following priority order: City or Town Limit, County Line, State Line.

NOTES

1. MAINTAIN A MINIMUM OF 500' FROM ANY GUIDE SIGN.
2. MAINTAIN A MINIMUM OF 400' BETWEEN ANY OF THESE SIGNS.

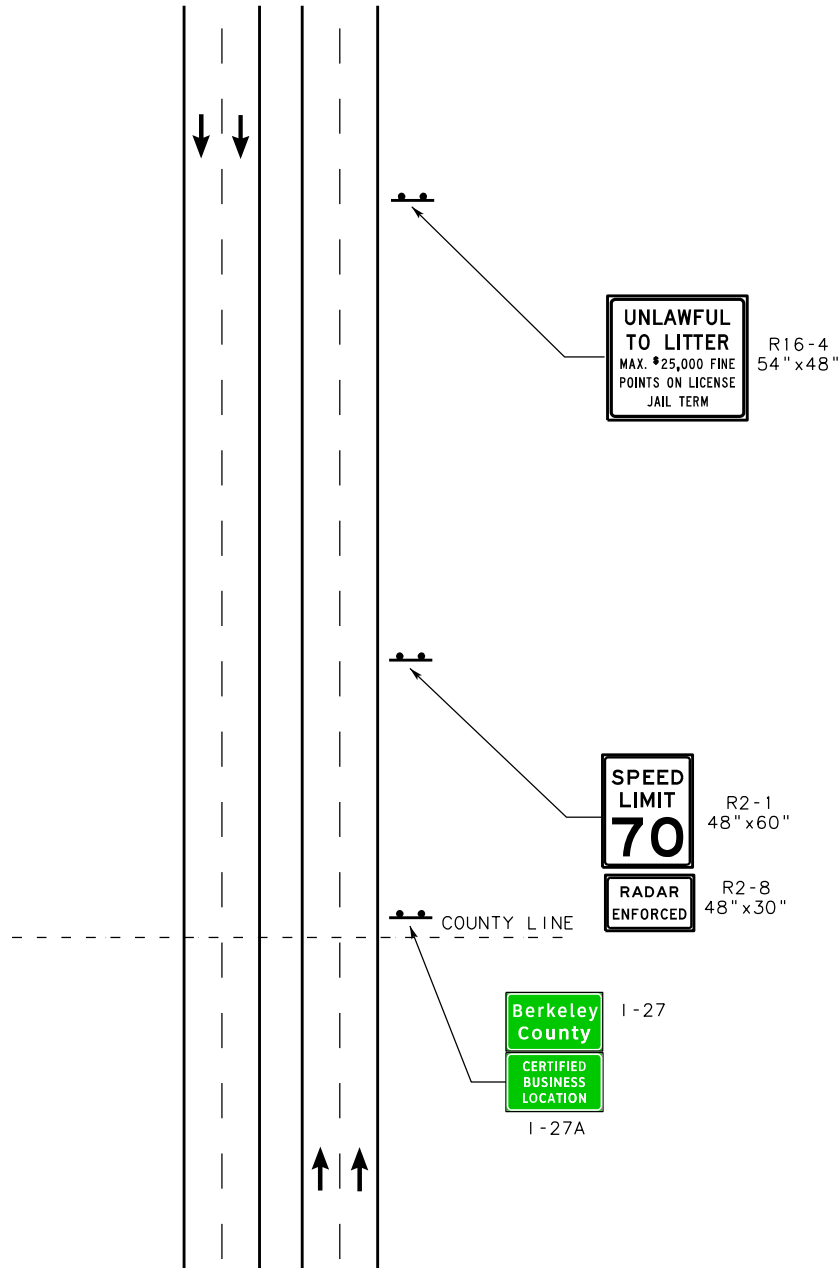

FIGURE 42
MISCELLANEOUS SIGNS
AT COUNTY LINE ON
FREEWAYS AND EXPRESSWAYS

2.5.14.7 Stream Name Sign (I-3B, C, D, and E, and I-50A)

This sign should be installed on all highways, except County Routes with less than 500 ADT, to show the name of the body of water spanned by structures 50 feet or more in length. The sign should be installed within 25 feet of the end of the bridge structure. Where the bridge has been given a name, the Bridge Name sign (I-50A), shall be installed in the median where present at the end of the bridge, and the River or Creek Name sign shall be installed on the right side of the structure. The I-50A and I-3 may be combined. I-3B is for a river crossing, I-3C is for a creek crossing, I-3D is for a run crossing, and I-3E is for a lake crossing.

2.5.15 Park and Ride Signing (D4-2)

PARK & RIDE (D4-2) signs with appropriate I-33R or I-33L arrows mounted underneath shall be used to direct road users to park and ride facilities. Within park and ride facilities PROHIBITED IN PARK & RIDE/CAMPING UNATTENDED TRAILERS/PUBLIC AND PRIVATE SALES (R5-5P) and UNLAWFUL TO LITTER (R16-4) signs shall be installed. PUBLIC AND PRIVATE SALES PROHIBITED (R16-5) and PROHIBITED NON-MOTORIZED DETACHED TRAILERS (R16-5A) signs may also need to be installed in areas where there is a specific problem. See Figure 43 for typical signing for a park and ride facility.

2.5.16 Recreational Facility Signing

Recreational facility signing generally has brown background with white legend and border. Following are guidelines for this signing.

1. Directional signing may be installed on freeways only for recreational facilities such as State Parks which are open year round and contain facilities to accommodate visitors for multiple days. A supplemental guide sign consisting of white legend on a brown background should be installed at least 800 feet beyond the One Mile Advance Guide sign. Signing should also be installed on the exit ramp as part of the Ramp Directional sign.
2. Signing on expressways may be considered for facilities which are open twenty-four hours and which have attendants on duty. A supplemental guide sign consisting of white legend on a brown background with the message NEXT LEFT/RIGHT should be installed at least 600 feet beyond the Junction Marker or One Mile Advance Guide sign, or if none then at least 600 feet before the Intersection Direction sign. Directional and destination signing for State Parks and State-sponsored attractions shall be in accordance with Traffic Engineering Directive 211 and shall have white legend on a brown background. Signing may also be installed for these facilities under the TODS program.
3. Signs may be installed on two-lane roads on the approach to the site or approach to county roads serving the recreational facility. Facilities for which signs may be installed include public hunting areas, fishing access sites, boat ramps, walking trails, ATV trails, fish hatcheries, game farms, beaches, monuments, and historic sites. Signs for these facilities consist of a 24 inch brown and white sign (DS Series) with appropriate symbol or words and brown and white arrow (DS-102) located within 100 feet of the intersection serving the facility. The background of the arrow must match the background of the sign. Beyond the intersection a DS sign

with a distance plaque (DS-103) may be installed to confirm to motorists that they are headed in the correct direction and to let them know the distance to the facility. See Traffic Engineering Directive 211 for additional details.

2.5.17 Specific Motorist Service Signing and TODS/LOGO Signing

Service signs have a blue background with white legend and border. The installation of Specific Motorist Services Signing is based on many factors. These include the degree of access control associated with each highway facility, the urban or rural environment of each highway facility, the legal limitations imposed on the installation of privately-owned outdoor advertising signs adjacent to the highway right of way, and the distance between the business and the highway facility. Any business being considered for Specific Services signing shall satisfy the minimum warrants for Gas, Food, Lodging, Camping, or Attraction contained in the current edition of the Division of Highway's booklet, "LOGO – TODS/LOGO SIGNING PROGRAMS." In large urban areas including Charleston and Wheeling all motorist services (except emergency medical facilities) are generally within sight and/or available to the traveler at reasonably frequent intervals along the route. Therefore, no Motorist Services signing (except for emergency medical facilities) shall be installed in these large urban areas. LOGO-TODS/LOGO signing is installed on freeways through other smaller urban areas.

2.5.17.1 TODS/LOGO Signing for Interstate Highways

The Division of Highways has a "LOGO - TODS/LOGO SIGNING PROGRAMS" for specific types of highways in West Virginia. Refer to the LOGO - TODS/LOGO sign booklet to obtain more detailed information regarding this program. Note the TODS/LOGO signing on freeways and expressways in Figures 26, 27, and 29.

2.5.17.2 TODS/LOGO Signing for Expressways

Under the TODS/LOGO portion of this program GAS, FOOD, LODGING, CAMPING, and ATTRACTIONS signing may be installed for qualifying businesses on the rural Expressway Highway System. Refer to the LOGO - TODS/LOGO sign booklet for the routes included in this program and to obtain more detailed information regarding this program. Where GAS, FOOD, LODGING, CAMPING, or ATTRACTIONS are available at expressway intersections but the owner chooses not to participate in the LOGO TODS/LOGO program, a 30 by 30 service symbol sign (D9 SERIES) shall be mounted underneath the Advance Intersection sign. At intersections with crossroads in which services are located in only one direction, an advance turn arrow (M5-1RA/LA 28 by 21) shall be used underneath the generic service symbol sign. A 24 by 24 service symbol sign with an arrow (M6-1R/LA) shall be mounted underneath the Intersection Direction sign. At intersections with US or WV signed routes the advance service symbol sign may be mounted underneath the JUNCTION GUIDE SIGN or installed as a stand-alone sign assembly. Common generic service symbol signs include the following: GAS (D9-7), FOOD (D9-8), LODGING (D9-

9), GAS/DIESEL (D9-11), and CAMPING (D9-3 or D9-3A). Note the TODS/LOGO signing on Figures 27 and 29. For interchanges on expressways Advance Service Signs (E10-1), when used shall be located 800 to 1,000 feet beyond the EXIT 1 MILE sign and shall list the appropriate services with the legend NEXT RIGHT. Symbol Service Signs 24 by 24 with appropriate Final Turn Arrows 21 by 15 shall be mounted below the Ramp Directional Sign.

3.0 SCHOOL SIGNING

3.1 School Zone Signing

School Zone Signing shall be placed on highways where the school property abuts the highway. This excludes freeways and expressways where the right of way is controlled access and where there is a fence separating the highway from the school. Signing consists of SCHOOL (S1-1) and AHEAD (S1-1C) signs and SCHOOL SPEED LIMIT 15 (S4-3A) WHEN CHILDREN ARE PRESENT (S4-2) or SCHOOL SPEED LIMIT 15 (S4-3A) WHEN FLASHING (S4-4) signs where there are school flashers. An END SCHOOL ZONE (S5-2) sign should be installed to identify the end of the school zone.

In rural areas with speed limits of 55 mph and/or where curves or other obstructions limit the safe stopping sight distance to the school, ADVANCE SCHOOL SPEED LIMIT WARNING (S4-5) signs should be installed to supplement the S1-1 and S1-1C signs. The S4-3A/ S4-2 and S4-3A/S4-4 signs should be installed within 125 feet of the approach to the school property line or as directed by the engineer. The S1-1 and S1-1C signs should be installed 150 to 700 feet from the S1-1 and S1-1C signs. If used the S4-5 sign should be installed between the S1-1 and S1-1C and the S4-3A/S4-2 and S4-3A/S4-4 sign. School signs have a fluorescent yellow-green background with black legend and border. See Figure 44.

3.2 School Crossing Signing

School crosswalks located within a school zone and within 125 feet of the S4-3A/S4-2 and S4-3A/S4-4 sign do not need additional signing. Longer school zones where internal school crossings are located more than 125 feet from the S4-3A/S4-2 and S4-3A/S4-4 sign should be supplemented with the SCHOOL CROSSING ASSEMBLY installed at the crosswalk. This assembly consists of a SCHOOL (S1-1) sign and a diagonal downward pointing arrow plaque (S1-1A). When the school crosswalk is outside a school zone, a SCHOOL CROSSING ASSEMBLY shall be installed at the crosswalk and an ADVANCE SCHOOL CROSSING ASSEMBLY consisting of a S1-1 sign and S1-1C plaque or DISTANCE PLAQUE (S1-1B) shall be installed 150 to 700 feet in advance of the crosswalk. See Figure 44.

NOTE:

1. THE R1-1 AND R5-1 SHALL BE 30" WHEN ENTERING FROM A TWO-LANE HIGHWAY AND 36" WHEN ENTERING FROM A MULTI-LANE HIGHWAY.

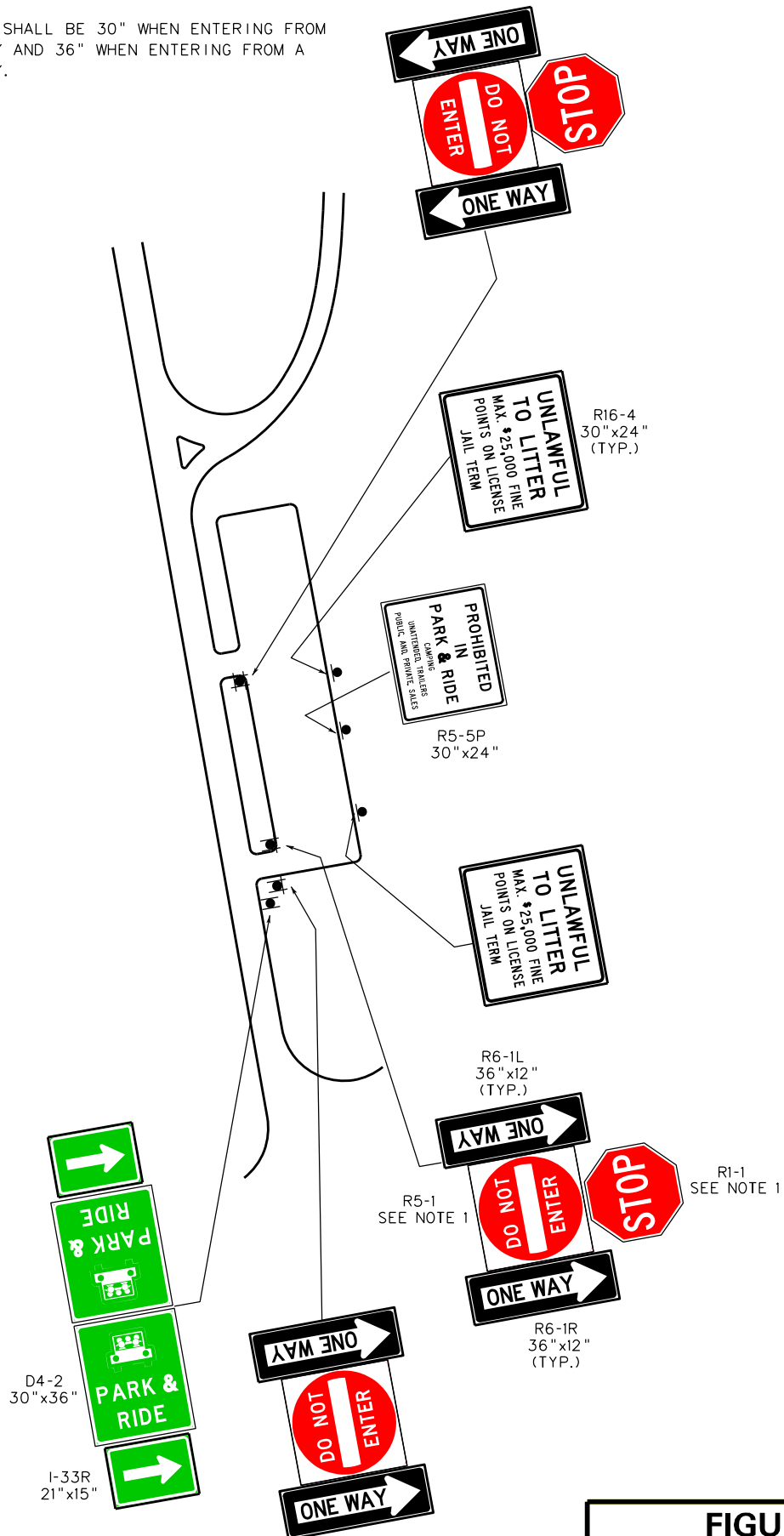
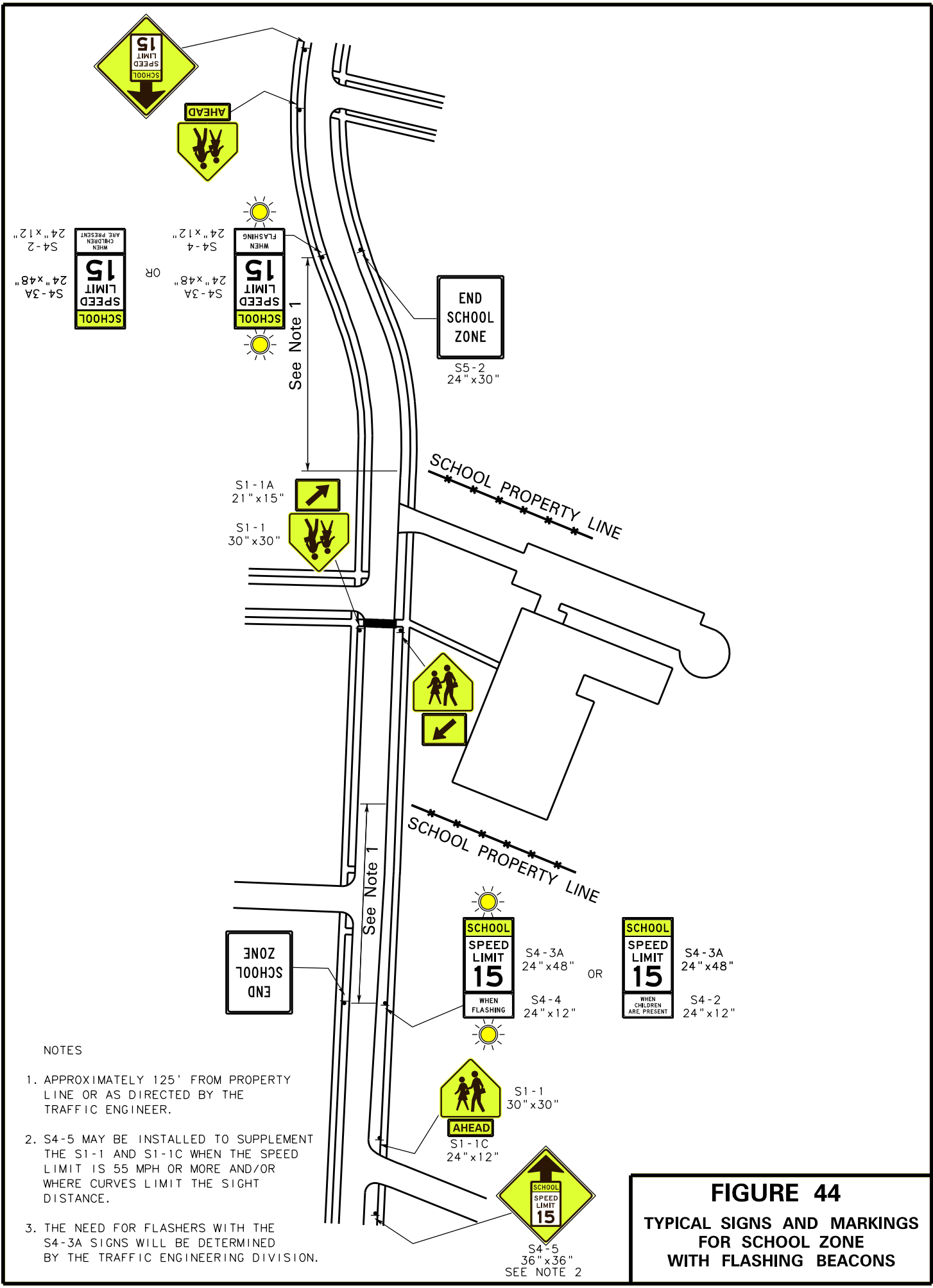

FIGURE 43
PARK AND RIDE
SIGNING



NOTES

1. APPROXIMATELY 125' FROM PROPERTY LINE OR AS DIRECTED BY THE TRAFFIC ENGINEER.
2. S4-5 MAY BE INSTALLED TO SUPPLEMENT THE S1-1 AND S1-1C WHEN THE SPEED LIMIT IS 55 MPH OR MORE AND/OR WHERE CURVES LIMIT THE SIGHT DISTANCE.
3. THE NEED FOR FLASHERS WITH THE S4-3A SIGNS WILL BE DETERMINED BY THE TRAFFIC ENGINEERING DIVISION.

FIGURE 44
TYPICAL SIGNS AND MARKINGS
FOR SCHOOL ZONE
WITH FLASHING BEACONS

3.3 School Area Signing

School Areas are locations not within a school zone and not at a school crossing, but where a school zone or school activity is located just off the highway along an intersecting road or street. Although neither a school zone nor school crossing may be installed on the highway, a S1-1 sign with a plaque such as 40 MPH WHEN FLASHING (or other appropriate speed) and a flasher may be installed to alert motorists. On an expressway the sign should be installed 800 to 1000 feet from the intersecting road and at least 400 feet from any adjacent guide sign. On two lane roads the sign should be installed 300 to 500 feet from the intersecting road. See Figure 45 for an example of this signing on an expressway.

3.4 School Bus Stop Signing

SCHOOL BUS STOP signs (S3-1) should be installed in advance of locations where a school bus, when stopped to pick up or discharge passengers, is not visible to road users for an adequate distance and where there is no opportunity to relocate the school bus stop to provide adequate sight distance. Refer to Traffic Engineering Directive 201 for details. Signs should be installed in advance of the school bus stop at distances specified in Table 1 on page 27.

3.5 School Bus Entering Signing

A SCHOOL BUS ENTERING (S3-5) sign may be installed on expressways or conventional roads on the approaches to intersections where sight distance does not meet the safe stopping sight distance or where the entrance of school busses is unexpected.

3.6 Reflective Sign Support Strips for School Signing

Fluorescent yellow-green reflective sign support strips shall be placed on the flange of u-channel supports for all School-related signs having fluorescent yellow-green background. SCHOOL signs include School Zone Signing, School Crossing Signing, School Area Signing, and School Bus Stop Signing. The post strips shall face approaching traffic.

4.0 DELINEATION

Delineators may be white, yellow, or red, or a combination in a back to back configuration, depending upon the location. The color of delineators placed on freeways, expressways, and ramps shall match the color of the edge line that is on the same side of the roadway as the delineator. White delineators shall always be installed on the right side of multilane highways. Yellow delineators shall be installed on the left side of multilane highways on guardrail or barrier. Yellow delineators shall not be installed on the left side of conventional two-lane two-way roadways. Red delineators shall be installed only facing wrong-way traffic. Red delineators shall be installed facing wrong way traffic on exit ramps and facing traffic on both sides of truck escape ramps. Delineators shall be located along the entire length of freeways and expressways, both in tangent and curve sections.

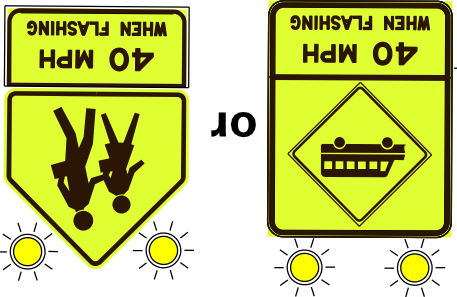

OR



100' TO 300' FROM SIDE ROAD

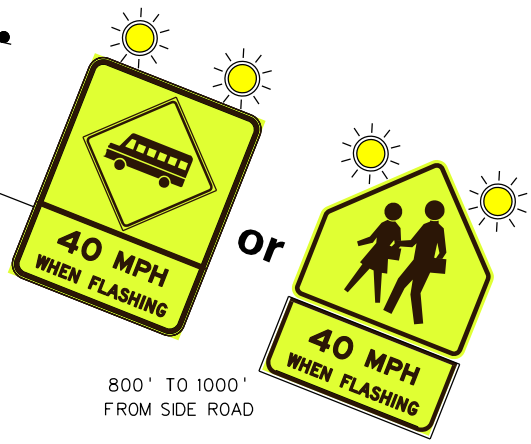

800' TO 1000'
FROM SIDE ROAD

NOTE:
SEE FIGURES 4, 5, AND 6 FOR
REGULATORY SIGNING.

FIGURE 45
SCHOOL AREA SIGNING
ON AN EXPRESSWAY

On the through roadway, plastic white delineators shall be spaced at 300-foot centers on tangent sections on the right side of the roadway. Where concrete barrier is present Type B-1 (8 by 12) delineators shall be mounted on top of the barrier at the same spacing as that along the tangent or curved section of roadway. Delineators shall not be installed in the guardrail flare or CST. The mounting details for Type B-1 delineators are shown on Standard Detail TE 11-5. In addition, yellow delineators shall be installed on the left side of the mainline of freeways and expressways where guardrail is present, as shown in Standard Details Volume 2. Because the supports are different when delineators are soil anchored as opposed to being mounted on the guardrail, the Delineator Quantity Summary shall differentiate the two installation methods.

On curves, the spacing of delineators in advance of, within the curve, and beyond the curve shall be determined by Table 3 and also in Standard Details Volume 2. The radius of curve, if known, should be used to determine spacing. Within interchange areas spacing for mainline delineators shall be 100 feet but spacing within curves shall be determined using the spacing charts in Standard Details Volume 2. Double white delineators shall be placed along the right side of deceleration and acceleration lanes at interchanges. For left-turn lanes on expressways yellow delineators shall be spaced at 25 feet and be located as shown in Standard Details Volume 2. Plastic white delineators spaced at 25 feet should also be placed along developed right turn lanes but shall not be installed where a shoulder has been painted as a right turn lane.

Table 3 - Guidelines for Delineator Spacing

Degree of Curve	Radius in Feet	Spacing on Curve	Spacing in Advance & Beyond Curve		
			1st Space	2nd Space	3rd Space
0 to 1.5	>10,000 to 3,821	300	300	300	300
1.5 - 1.7	3,820 - 3,400	185	300	300	300
1.8 - 2.2	3,399 - 2,600	160	300	300	300
2.3 - 2.7	2,599 - 2,100	140	280	300	300
2.8 - 3.2	2,099 - 1,800	130	260	300	300
3.3 - 3.8	1,799 - 1500	120	240	300	300
3.9 - 4.5	1,499 - 1,300	110	220	300	300
4.6 - 5.4	1,299 - 1,100	100	200	300	300
5.5 - 6.7	1099 - 850	90	180	270	300
6.8 - 8.5	849 - 670	80	160	240	300
8.6 - 11.0	669 - 520	70	140	210	300
11.1 - 14.9	519 - 390	60	120	180	300
15.0 - 21.0	389 - 270	50	100	150	300
21.1 - 31.0	269 - 180	40	80	120	240
31.1 - 48.0	179 - 120	30	60	90	180
48.1 - 75.0	119 - 75	20	40	60	120
> 75	> 75	20	20	30	60

Notes: Delineator spacing shall be measured at the edge of pavement nearest to the location of delineator. Spacing shall be determined from the curve data shown on the curve data sheet of the plans. Spacing on tangents shall be 300 feet. The spacing on the curve is found from the formula $S = 3\sqrt{R - 50}$, where R is the Radius of the curve in feet. The spacing to the first delineator in advance of and beyond the curve is 2 S. To the next delineator 3S, and to the next 6S, but not to exceed 300 feet. Minimum spacing is required.

5.0 SIGN VERTICAL AND LATERAL CLEARANCE

5.1 Sign Vertical Clearance

In both rural and urban areas signs shall be installed at a height of 7 feet to the bottom from the elevation of the nearest edge of pavement. When a secondary sign is mounted under the primary sign, the minimum height of the secondary sign should be 5 feet. If the assembly is installed along a sidewalk or where parking is prevalent the minimum mounting height shall be 7 feet. Route marker assemblies which include multiple signs shall be installed at a height of 7 feet to the bottom sign in the assembly. Overhead signs shall be installed at a minimum height of 17.5 feet to the bottom of the sign, or if luminaires are installed the signs shall be a minimum of 18 feet 3 inches above the pavement. Signs spanning over a sidewalk shall be installed at a minimum height of 7 feet above the sidewalk. See Figure 46.

5.2 Sign Lateral Clearance

In rural areas the nearest edge of the sign face for signs mounted along the side of the roadway shall be 6 feet minimum from the edge of the shoulder, or if no shoulder is present the nearest edge of the sign should be 12 feet from the edge of pavement. If guardrail or a raised non-mountable curb is present, the sign shall be installed 2 feet behind the curb or back of the guardrail. In urban areas where sidewalk exists the signs shall be installed 2 feet from the back edge of the sidewalk. For overhead sign structures in urban areas with non-mountable curb, the nearest edge of the foundation shall be four feet minimum from the face of the curb. Where guardrail is present the nearest edge of the foundation shall be four feet minimum from the back of the guardrail. See Figure 48 for typical horizontal and vertical clearances for signs. All signs installed within the clear zone shall have breakaway supports. See Figure 47 for Typical Locations of R1-1, R1-2, and D16-1 or D16-2 signs at minor rural intersections.

6.0 SIGN SUPPORTS

Sign supports, both overhead and roadside, shall be designed in accordance with Division of Highways Standard Specifications, Standard Details, and the requirements of the AASHTO Standard Specifications for Structural Supports for Highway Signs, Luminaires, and Traffic Signals.

6.1 Ground Mounted Sign Supports

The type of supports used shall be as follows:

- A. All ground mounted guide and information signs greater than 40 square feet shall be erected on S or W shape breakaway supports. All standard signs 20 square feet or more shall be on S or W shape breakaway supports. Smaller ground mounted guide and information signs shall be erected on U-channel posts.
- B. All exit gore signs shall be mounted on S shape breakaway supports with omni-bolts.
- C. All extruded panel ground mounted signs shall be on breakaway S or W shape supports.
- D. Warning and regulatory signs shall be erected on U-channel posts, breakaway pipe posts or breakaway S or W shape supports.

**ROADSIDE SIGN
IN RURAL AREA**

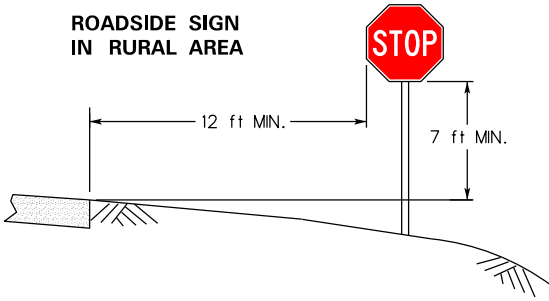

**ROADSIDE SIGN
IN RURAL AREA**

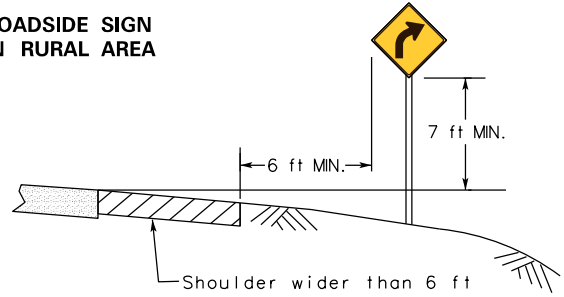

**ROADSIDE SIGN
IN BUSINESS,
COMMERCIAL, OR
RESIDENTIAL AREA**

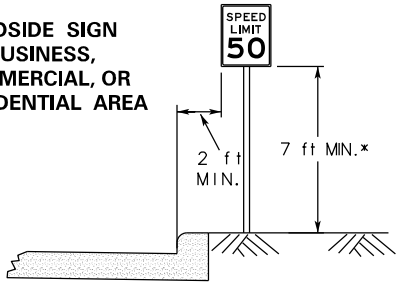

*Where parking or pedestrian movements are likely to occur

**WARNING SIGN WITH ADVISORY
SPEED PLAQUE IN RURAL AREA**

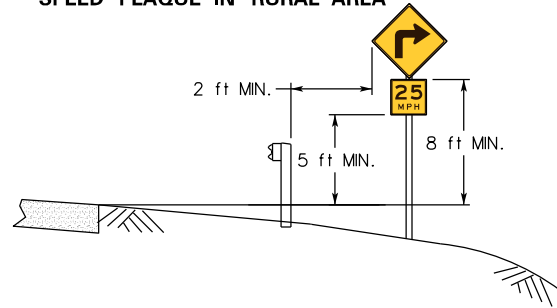

**ROADSIDE ASSEMBLY
IN RURAL AREA**

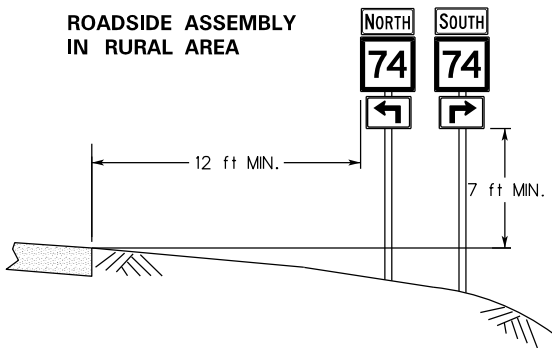

**SIGN ON NOSE
OF MEDIAN**

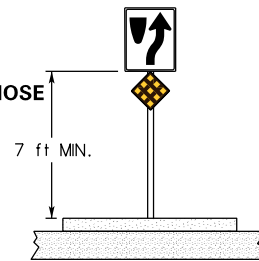

FREEWAY OR EXPRESSWAY SIGN WITH SECONDARY SIGN

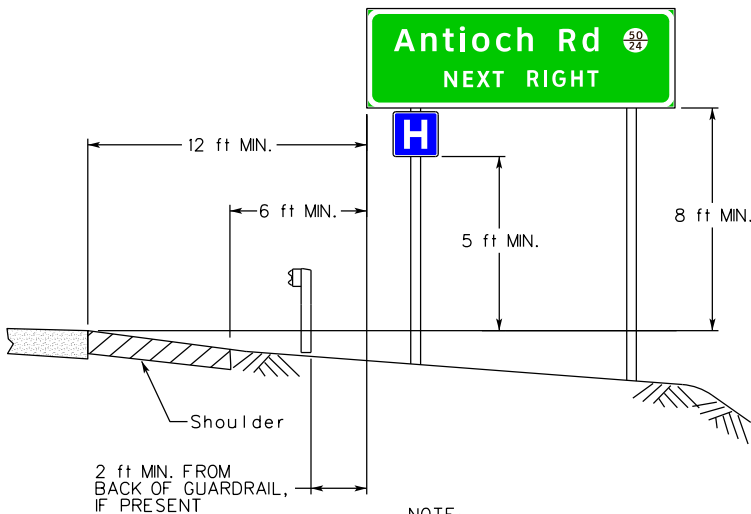

NOTE:

1. IF THERE IS ANY DEVIATION FROM THE MINIMUM DISTANCES SHOWN ON THIS FIGURE, THE REASON SHOULD BE ADEQUATELY DOCUMENTED.

OVERHEAD SIGN



R3-9E

CENTER THE SIGN OVER THE CENTER LANE

17'-6" MIN.

Shoulder

2 ft MIN. FROM FACE OF BARRIER CURB OR 4 ft MIN. FROM BACK OF GUARDRAIL TO FOUNDATION

FIGURE 46
EXAMPLES OF
VERTICAL & HORIZONTAL
LOCATIONS OF SIGN
INSTALLATIONS

FIGURE 47

TYPICAL SIGNING LAYOUT FOR MINOR RURAL INTERSECTIONS

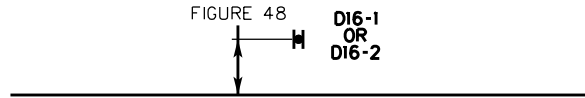

EXPRESSWAY, TRUNKLINE, FEEDER

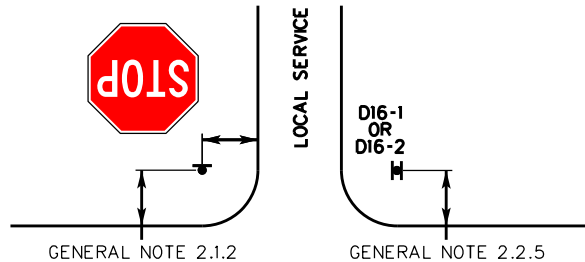
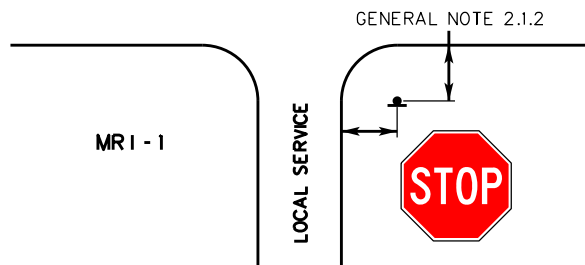

EXPRESSWAY, TRUNKLINE, FEEDER

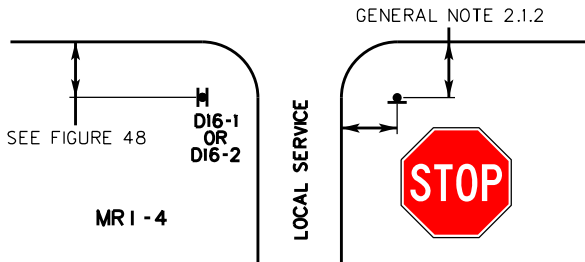

MR1-4

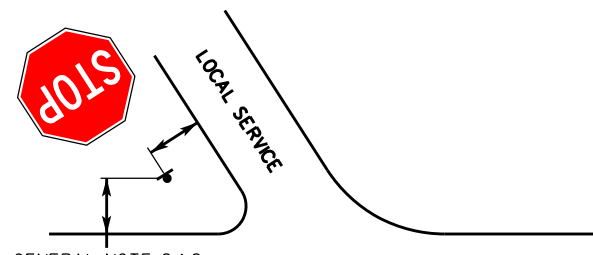

EXPRESSWAY, TRUNKLINE, FEEDER

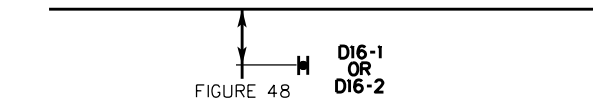

MR1-2

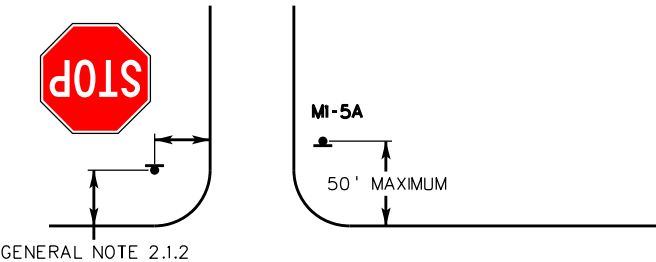

EXPRESSWAY, TRUNKLINE, FEEDER

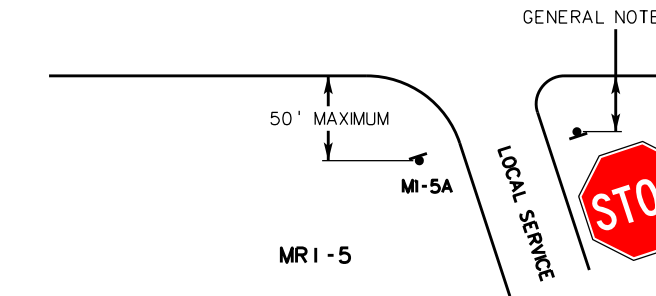

MR1-5

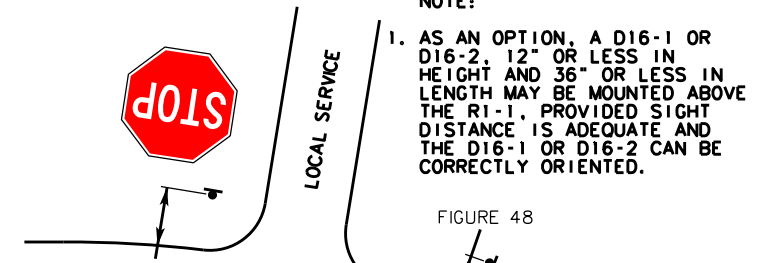

EXPRESSWAY, TRUNKLINE, FEEDER

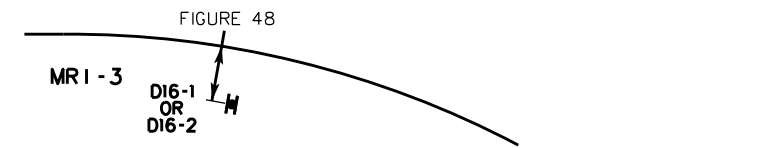

MR1-3

GENERAL NOTES

1. AS AN OPTION, A D16-1 OR D16-2, 12" OR LESS IN HEIGHT AND 36" OR LESS IN LENGTH MAY BE MOUNTED ABOVE THE R1-1, PROVIDED SIGHT DISTANCE IS ADEQUATE AND THE D16-1 OR D16-2 CAN BE CORRECTLY ORIENTED.

- 1. MINOR RURAL INTERSECTION**
- THIS INTERSECTION TYPE IS DEFINED AS A US OR W.VA. DESIGNATED EXPRESSWAY, TRUNKLINE, OR FEEDER HIGHWAY INTERSECTING ONE OR MORE LOCAL SERVICE DESIGNATED ROADWAYS. THE ADT OF THE LOCAL SERVICE ROADWAY WILL NOT BE GREATER THAN 1500.
- 2. PLACEMENT OF SIGNS**
- 2.1 STOP SIGNS
 - 2.1.1 STOP SIGNS SHALL BE SITUATED IN SUCH A MANNER THAT THE SIGN MESSAGE SHALL NOT BE VISIBLE FROM THE EXPRESSWAY, TRUNKLINE, OR FEEDER HIGHWAY.
 - 2.1.2 STOP SIGNS SHALL BE LOCATED A MINIMUM DISTANCE OF SIX (6) TO TWELVE (12) FEET FROM THE PAVEMENT EDGE OF THE EXPRESSWAY, FEEDER, OR TRUNKLINE, BUT CAN BE A MAXIMUM OF FIFTY (50) FEET IF CONDITIONS MAKE SUCH NECESSARY. SEE FIGURE 48.
 - 2.1.3 STOP SIGNS MAY BE LOCATED IN POSITIONS OTHER THAN THOSE SHOWN ON THE DRAWINGS ONLY IF IT CAN BE ADEQUATELY JUSTIFIED.
 - 2.2 D16 SERIES SIGNING.
 - 2.2.1 D16 SERIES SIGNS SHALL BE SITUATED IN SUCH A MANNER THAT THE SIGN MESSAGE SHALL BE SEEN AS FAR IN ADVANCE AS POSSIBLE BY VEHICLES ON THE EXPRESSWAY, FEEDER, OR TRUNKLINE.
 - 2.2.2 D16 SERIES SIGNING THAT ARE MOUNTED BACK TO BACK ARE TO BE LOCATED IN POSITIONS SHOWN ON DRAWINGS, UNLESS OTHER POSITIONING CAN BE ADEQUATELY JUSTIFIED.
 - 2.2.3 DRAWING MR1-1, MR1-2, MR1-3, AND MR1-4 SHOW THE PROPER RELATIONSHIP OF THE LOCATION OF D16 SIGNS TO "STOP" SIGNS. ANY EXCEPTIONS WILL HAVE TO BE ADEQUATELY JUSTIFIED.
 - 2.2.4 DRAWING MR1-5 SHOWS THE PROPER PLACEMENT OF MI-5A SIGNS. MI-5A SIGNS ARE TO BE ERECTED ONLY IF D16-1 OR D16-2 SIGNS ARE NOT ERECTED AT THE INTERSECTION IN QUESTION.
 - 2.2.5 ON 2 LANE, 2 WAY ROADWAYS D16-1 OR D16-2 MAY BE INSTALLED BACK TO BACK ON ONE SIDE IF THE PREFERRED LOCATION ON THE RIGHT SIDE IS NOT FEASIBLE.

6.1.1 Design of Ground Mounted Sign Supports

The size of ground supports may be determined from the Standard Details based on the type support (U-channel, S or W shape, or Pipe Post), square footage of the sign, and the height from the ground to the center of pressure (centroid) of the sign. The number of supports required is based on the length and area of the sign, the punching standards for the standard signs (Standard Details TP1-1 through TP1-5), and the structural capabilities of the supports.

The type and length of supports shall be entered on the Estimate and Summary of Quantities Sheet.

Reflective Post Support Strips (RPSS) shall be used on all regulatory signs associated with freeway ramps and at-grade intersections along expressways.

6.1.2 Examples of Designing Sign Supports and Foundations

- A. Design for a 24 by 30 R2-1 sign mounted at 7 feet to the bottom and assume there is a slope that adds 2.0 feet to the height of the center of pressure. The height of the center of pressure would be $7 + 1.25$ (half the 2.5 feet height of sign) $+ 1$ (allowance for slope) = 9.25 feet. The area of the sign is $2 \times 2.5 = 5.0$ square feet. Using Standard Detail TE1-7 (Roadside Sign Supports U-Channels – small standard signs under nine square feet usually have one support) enter the chart using the TOTAL SQUARE FEET OF SIGN AREA = 5, and the DIMENSION FROM GROUND TO CENTER OF PRESSURE = 9.25, and determine that one 4.00 #/FT U-Channel is the appropriate support. Note also on this same TE1-7 that the embedment of the post shall be 3.5 feet. The U-channel post length required is 15'-0".
- B. Design for a 48 by 48 W1-1 sign mounted at 7 feet to the bottom and assume the slope adds one foot to the left post and two feet to the right post. The height of the center of pressure would be $7 + 2.8$ (half the 5.6 feet height of sign) $+ 1.0$ (for slope) = 10.8 feet (for the longest support). The area of the sign is $4 \times 4 = 16.0$ square feet. Using Standard Detail TE1-7 (Roadside Sign Supports U-Channels - all 48 by 48 warning signs are installed on two posts) enter the chart using the TOTAL SQUARE FEET OF SIGN AREA PER SUPPORT = $4 \times 4 / 2 = 8$, and the DIMENSION FROM GROUND TO CENTER OF PRESSURE = 10.8, and determine that two 6.00 #/FT BB U-Channels are the appropriate support. Note also on this same TE1-7 that the embedment of the post shall be 3.5 feet. The U-channel post lengths required would be 15'-6" and 16'-6".
- C. Design for a 144 by 96 extruded panel guide sign mounted at 7 feet to the bottom and assume the slope adds one foot to the left post and two feet to the right post. The height of the center of pressure would be $7 + 4.0$ (half the 8.0 feet height of sign) $+ 2.0$ (for slope) = 13.0 feet. The area of the sign supported by each support is $(12 \times 8) / 2 = 48.0$ square feet. Using Standard Detail TE1-3B (Roadside Sign Supports Breakaway Type) enter the chart using the TOTAL SQUARE FEET OF SIGN AREA PER SUPPORT = 48.0, and the longest DIMENSION FROM GROUND TO CENTER OF PRESSURE = 13.0, and determine that two W8X18 are the appropriate supports. On this same TE1-3B note that the center to center spacing of the posts will be $0.60 \times L$ (0.6 X length of sign) or 7.2 feet. The foundation required for each of the posts is

found on the chart on Standard Detail TE1-3C using the W6X12 post type. The foundation required has a diameter of 2'-6", a depth of 5'-6", and requires 1.0 cubic yards of concrete. Add the stub length of 2'-6" found on Standard Detail TE1-3C to the final post lengths to determine the total post lengths to the nearest half foot. Post lengths required for this assembly are 18'-6" and 19'-6".

6.2 Overhead Sign Supports

The design of overhead sign supports shall be in accordance with DOH Standard Details and be based on the use of tubular structural members of galvanized steel or aluminum conforming to Division of Highways Standard Specifications and shall be a type available from experienced fabricators of overhead structures. Special designs shall not be used without prior approval from the Division of Highways. Structural attachments to overpass bridges for use as overhead sign supports should be avoided. If it is necessary to install a sign near a bridge structure, a separate overhead sign structure shall be installed in front of the bridge. Overhead sign structures shall not be installed underneath or just beyond bridge structures where sight distance could be restricted by the bridge structure nor should they be located too near traffic signals as they may restrict sight distance to the signal. Care should be taken to locate overhead signs in the proper place when lane control signs are being used and overhead signs should never conflict with pavement markings.

All overhead sign structures shall ordinarily be protected by guardrail, or other suitable barrier. Whenever possible, sign locations should be adjusted to take advantage of existing guardrail or, if this is not possible, short lengths of guardrail should be installed to protect the overhead structure. The length of guardrail shall be in conformance with Division of Highways Standard Details Volume 1 in order to develop maximum strength of the rail.

A schematic drawing of the overhead sign structure and any necessary guardrail details shall be included with the contract plans at the Office Review. Where overhead sign cantilevers or box truss structures are to be mounted on new bridges or median barrier, use pilasters or flared barrier section. Overhead sign structures shall be designed so that the bottom of the sign lighting is a minimum of 17.5 feet above the pavement for new construction or 17.0 feet above the pavement when the structure is being reused in a renovation project. All overhead signs or sign structures structurally attached to bridge steel members or parapet walls shall be analyzed for proper load and connection by the consultant and fabricator/contractor for proper installation and safety.

6.3 Foundations

All breakaway S or W shape supports shall be bolted to stub posts having a length corresponding to the size of the post as shown on Standard Detail TE1-3C (Stub length shall be included in final post length). The stub post shall be embedded in concrete as shown on TE1-3A. U-channel posts shall either be driven directly in earth or be installed in concrete footers. U-channel post assemblies, both back-to-back and those that are not back-to-back, may require concrete foundations and/or approved breakaway devices. There are various factors that must be considered when making this determination, including but not necessarily limited to operating speed, cross slope where the assembly is installed, protection provided for the assembly, placement of the assembly in relation to the clear zone, and post

spacing. The designer should refer to the specific guidance that is provided on the Standard Detail sheets for the type of supports being considered to make a final determination in regard to the need for concrete foundations and/or breakaway devices.

Pipe posts shall be provided with breakaway slip bases as shown on Standard Detail TE1-5A. Design of footings for all roadside mounted signs on breakaway S or W shape supports shall be as indicated on Standard Detail TE1-3C. Both S and W shape supports require reinforced concrete footings. For overhead structures, footings shall be designed in accordance with Standard Details Volume 2 to accommodate the type of structure used and shall project 18 inches above the ground line. For roadside supports the estimate of foundation size and the amount of concrete shall be included in the Estimate and Summary of Quantities Sheets. For overhead structures the estimated amount of concrete shall be included in the Schematic Detail and in the Summary of Quantities.

6.4 Renovation Projects

For sign renovation projects it is necessary to determine whether the supports and foundations can be reused. Breakaway supports can be reused if they are the correct size, correct spacing, and correct offset for the new sign, have no rust, and are in the correct location. New breakaway supports may be added to existing breakaway stubs if the existing stubs are in good condition and the stub posts are a current size used by the Division and can be matched with current specifications and Standard Details Volume 2. Foundations should be vertical, be free from excessive spalling, and not be projecting above the ground more than 6 inches where unprotected by guardrail. If the foundation has more than six inches of fill on top of it and the fill cannot be removed, the foundation should not be reused.

7.0 SIGN LIGHTING

All guide signs erected over the roadway should be illuminated whenever possible by means of external illumination. Overhead signs shall be illuminated in accordance with DOH Standard Specifications using LED fixtures only as approved by DOH in both urban and rural areas. The minimum height above the pavement for sign lighting fixtures shall be 17.5 feet to the bottom for new projects and 17.0 feet for renovation projects. All details concerning power supply shall be coordinated with the local power company by persons preparing sign plans.

The Summary of Quantities Sheet shall show a bid item for each sign lighting installation. The number and spacing of luminaires and Zee brackets shall be shown on the overhead sign schematic. This information may be obtained from the Standard Specifications and Standard Detail TE6-3D.

The sign designer shall also include power service, location of junction boxes, conduit runs, and voltage for each overhead sign requiring lighting.

8.0 DESIGN OF SIGNS

8.1 Sign Materials

A typical sign consists of three components: substrate or backing material, sign sheeting, and sign legend.

8.1.1 Sign Substrate

Aluminum materials are the primary substrate used for signs in West Virginia. The two main types of aluminum substrate are extruded panels and flat sheet materials. All larger guide signs shall be made of aluminum extruded panels. Smaller guide signs and all standard regulatory and warning signs shall be fabricated using flat sheet material. The overall dimensions and area of a sign as well as the size legend are used to determine the type substrate material to be used. Signs with the least dimension five feet or less should use flat sheet material. Any sign with the least dimension greater than five feet should be made from extruded panels.

All guide signs with legend size of 8 inch mixed case or greater shall have demountable legend and the sign substrate shall be made of extruded panels unless otherwise approved by Traffic Engineering Division. All guide signs with legend size of 6 inch mixed case or smaller shall be manufactured using flat sheet. Flat sheet aluminum signs are ordinarily designed in vertical and horizontal increments of six inches. The D16-X, however, may be designed in heights of 9 and 15 inches. Extruded aluminum panels are composed of pre-formed structural shapes bolted together to create the sign substrate. Extruded panels come in twelve and six inch heights. Signs made of extruded panels shall be designed in vertical increments of six or twelve inches and horizontal increments of six or twelve inches. If an extruded panel sign has multiple colors, the split between colors must be at the top or bottom of one of the twelve inch panels. Each color section shall be in even feet.

8.1.2 Sign Sheeting

The background sheeting on all guide, regulatory, and warning signs shall be in accordance with the latest DOH specifications and/or Traffic Engineering Directives. Fluorescent yellow-green sheeting shall be used for the background of all school signs. Fluorescent yellow sheeting shall be used for the background of all warning signs on freeways and expressways. Green or brown sheeting shall be used for the background of all guide signs. Blue sheeting shall be used for the background of all LOGO - TODS/LOGO signs.

8.1.3 Sign Legend

Legend can be applied to sign faces in three different manners: direct applied, demountable legend, and silk screening. Direct applied uses letters cut from sheeting and is attached to the sign using the adhesive on the back of the sheeting. Demountable legend consists of aluminum covered with sheeting and is riveted onto the sign face. Silk screening uses dye to color the portions of the sign background and/or message. White demountable legend and white direct apply legend shall be reflective and black demountable legend shall be non-reflective. Careful consideration shall be given to the message arrangement of multi-message signs to minimize the total sign area.

8.1.4 Sign Borders and Corner Radii

All signs shall have a border of the same color as the legend, at or just inside the edge of the sign. A dark border on a light background should be set in from the edge, while a light border on a dark background shall extend to the edge of the sign. See Appendix A.

8.2 Designing Guide Signs/Determining Sign Message

The first step in the sign design process is to determine the message of each of the guide signs using Section 8 and the latest version of Traffic Engineering Directive 220-1 “Control and Intermediate Destinations for Guide Signing on Interstate, US, and WV Numbered Highways.” Planning Division can provide the local names of roads as well as the county route number. Careful consideration shall be given to the message arrangement of multi-message signs to minimize the total sign area. See Appendix A for specific details about designing guide signs.

8.2.1 Legend Size and Spacing

All guide signs that show names of streets, roads, towns and cities shall have white reflective legend and border on green high intensity reflective background. Guide signs for recreational areas typically have a brown background and guide signs for services typically have a blue background. Legend size is dependent upon the classification and speed of the highway. The legend size for guide signs on freeways, expressways, conventional roads, and crossroad approaches to freeways and expressways shall be determined by using the tables in Appendix A. The legend size for D1 and D2 signs at intersections between US and WV Routes on conventional two lane roads having speed limits of 30 to 55 mph shall be a combination of 6-inch upper-case letters and 4.5-inch lower-case letters. See Sections 2.4.4 for legend size on conventional two lane US and WV routes on the approaches to other US and WV routes.

The legend size for County Road Name signs on two lane US and WV Routes on the approach to County Routes shall be a combination of 3-inch upper-case letters and 2.2-inch lower-case letters. If an action message is needed it shall use 2-inch all capital letters. If an advance sign is needed for a County Route intersection the legend size for the name of the road shall be a combination of 4-inch upper-case letters and 3-inch lower-case letters. The action message shall use 3-inch all capital letters. See Section 2.4.4.3 for legend size on conventional two-lane roads on the approach to county routes.

8.2.2 Rules for Sign Text Spacing

The determination of sign text layout shall be done by use of Appendix A and the following rule of thumb. For legend that has subscripts such as 5th or 3rd the “th” or “rd” shall be 75% the height of the 5 or 3. When used hyphens shall have a space 75% of the letter height both before and after. Spacing between fractions and the preceding or next word such as ½ MILE shall be 1.25 to 1.5 times the letter height. The height of the fraction shall be 1.25 to 1.5 times the letter height of the next word such as MILE. Abbreviations such as “St”, “Rd”, or

“OH” (for Ohio) shall be used without periods after the abbreviation.

When overhead signs are too large for the overhead sign structures, the length of the sign may be reduced by reducing the spacing between legend and between words by 75% of the value shown in sign design program GUIDESIGN.

8.2.3 Items Needed in Signing Plans

Signing plans may include all or some of the following: Title Sheet, Summary of Quantities, General Notes, Temporary Traffic Control Plan, Signing Quantities, Delineator Quantities, Quantities of Reflective Sign Support Strips, Signing Plans for the Mainline, Signing Plans for Interchanges and Major Intersections, Sign Fabrication Sheets, Overhead Sign Schematics, Sign Lighting General Notes, Sign Lighting Details, Guardrail Details, Miscellaneous Signing. Other signing details may be needed for clarification of specific design details. GPS coordinates shall be shown on the overhead sign schematics for each overhead sign. Use UTM coordinate system as required by the GIS Section of Planning Division.

8.2.4 Estimate and Summary of Quantities

The Estimate and Summary of Quantities shall be prepared after sign design has been completed. The Estimate of Quantities sheet shall have the assembly number of each individual sign assembly. A sign assembly is any grouping of signs sharing a common support system. This will be followed by a sign number listing every sign in the assembly and then the location will be given. The outside dimensions and square footage of each sign in each assembly will be shown. The square footage will be broken up into panel and flat sheet. The Traffic Engineering Division has Excel templates on their web page for use in creating estimates (signs, delineators, markings) summaries and cost estimates. These templates may be linked to Microstation files. A separate Estimate of Quantities shall be provided for delineators. Samples of the Estimate of Quantities for signing and for delineators are shown in Figures 48 and 49.

ASSEMBLY NUMBER	PROPOSED SIGN NUMBER	EXISTING SIGN NUMBER	PROPOSED LOCATION	EXISTING LOCATION	LAYOUT	FABRICATION SHT. NO.	SIGN DISPOSITION			SIGN QUANTITIES			REMARKS	SIGNING ESTIMATE OF QUANTITIES			UNIT PRICE	TOTAL AMOUNT	FOOTER CLASSIFICATION			
							SIGNAL POSITION	SIGNAL SIZE	SIGNAL COLOR	LENGTH	HEIGHT	WIDTH		SUB-TOTAL	TOTAL THIS SHEET	TOTAL THIS PROJECT				SIGNING ESTIMATE OF QUANTITIES	UNIT PRICE	TOTAL AMOUNT
762	RI-13		6145 CR 40/8	6145 CR 40/8	P-23		RWD	1.00	1.50	1.50												
763	M3-4A	M3-4A	62-00 CR 40/8	62-00 CR 40/8	P-23		RWD	2.00	1.00	2.00												
	MI-1700 MI-1						RWD	2.00	2.00	4.00												
	M3-3A	M3-3A					RWD	1.75	1.25	2.99												
	M3-2A	M3-2A					RWD	2.00	1.00	2.00												
	MI-1700 MI-1						RWD	2.00	2.00	4.00												
	M3-3A	M3-3A	--- EXH 4 ---				RWD	1.75	1.25	2.99												
764	DIO-FER		208-75 RAMP A				P-24	F-18	NEW	1.00	1.50											
765	LOR-5		210-40 RAMP A				P-24	F-37	NEW	5.00	13.00											
766	M3-1		211-05 RAMP A				RWD	4.00	4.00	16.00												
767	LOR-3	LOR-3A	211-63 RAMP A				P-24	F-37	RWD	5.00	13.00											
768	DIO-FER		22-00 RAMP A				P-24	F-18	NEW	1.00	1.50											
769	DIO-2	DIO-1	212-31 RAMP A				P-24	F-39	RWD	12.50	33.75											
770	LOR-2		212-72 RAMP A				P-24	F-37	RWD	5.00	13.00											
771	LOR-1	LOR-1A	214-07 RAMP A				P-24	F-37	RWD	5.00	13.00											
772	M3-4	M3-4	214-08 RAMP A				RWD	2.00	1.00	2.00												
	MI-1140 MI-4						RWD	2.00	2.00	4.00												
	M3-1						RWD	1.75	1.25	2.99												
	MI-688 MI-6						RWD	2.00	1.00	2.00												
	M3-3	M3-3					RWD	2.00	1.00	2.00												
	MI-688 MI-6						RWD	2.00	2.00	4.00												
	M3-1A						RWD	3.50	2.50	8.75												
773	DIO-FER		215-20 RAMP A				P-24	F-18	NEW	1.00	1.50											
774	RI-1	RI-1	215-91 RAMP A				P-24		RWD	3.00	9.00											
	RI-5	RI-5					RWD	3.00	3.00	9.00												
774	RI-5		215-90 RAMP A				P-24		NEW	3.00	9.00											
											SUB-TOTAL	112.26	303.75	410	93.0	38.5	14	27.5	81.0	0.6		

SIGNING ESTIMATE OF QUANTITIES		SIGNING ESTIMATE OF QUANTITIES		SIGNING ESTIMATE OF QUANTITIES		SIGNING ESTIMATE OF QUANTITIES	
ASSEMBLY NUMBER	REVISION	DATE	BY	REVISION	DATE	BY	REVISION

NO SCALE

DRAWN: [] CHECKED: [] APPROVED: [] DATE: []

SIGNING ESTIMATE OF QUANTITIES

SUPPORTS & FOUNDATIONS
SIGNALS

REMARKS:
 * - SEE EXCEPTION TO STANDARD PUNCHING DETAIL INCLUDED IN THE CONTRACT PLANS
 ** - REFLECTIVE SIGN SUPPORT STRIPS (SEE GENERAL NOTES AND SHEET XX)
 RWD - REMOVE AND DISCARD
 RRS - REMOVE AND SAVE
 STR - SIGN TO REMAIN
 IRS - INSTALLATION OF REUSABLE SIGN SUPPORT LENGTHS INCLUDE STUB LENGTHS WHERE REQUIRED.

FOR TYPE 1 BRACKET DETAILS SEE SHEET XX
 FOR TYPE 51 AND 52 BRACKET DETAILS SEE SHEET XX.

ASSEMBLIES 762 THRU 788

E-28

Project No.	Sheet No.	State	Fiscal Year	County	DIST
					XX

DELINEATORS

DELINEATORS

LOCATION	QUANTITY										
	SPACING	66194-002		66193-001		66193-001		66193-001		66193-001	
		XS-1Y (PER TET-S) 3"X3"	TYPE-B-1 (PER TET-S) 4"X4"	CLASO-1 (PER TET-S) 4"X4"	CLASO-1 (PER TET-S) 4"X4"	CLASO-1 (PER TET-S) 4"X4"	CLASO-1 (PER TET-S) 4"X4"	CLASO-1 (PER TET-S) 4"X4"	CLASO-1 (PER TET-S) 4"X4"	CLASO-1 (PER TET-S) 4"X4"	CLASO-1 (PER TET-S) 4"X4"
MAINLINE - EB & WB											
965-00 - 970-00	300	4									4
970-00 - 980-00	160	14									14
980-00 - 987-00	100	10									10
2-00 - 8-00	100	6	6		5	6					
MAINLINE - EASTBOUND											
24-00 - 46-00	100	13	14	1	1	9	3				27
46-00 - 55-00	300										
55-00 - 124-00	100			9	15	23	10				
124-00 - 138-40	120										
138-40 - 151-20	160			1	2	5	27	2			
151-20 - 184-20	100			1	1	5	4	3			
184-20 - 195-90	130			11	7	6	17	3			
195-90 - 229-90	100										
229-90 - 235-90	300			5	7	21	2	2			
235-90 - 265-90	100										
265-90 - 271-90	300										
E.O. 272-99.02 BK - 271-14-95											
271-90 - 289-76	160			12		12					
289-76 - 301-76	300			4		4					
301-76 - 335-56	130			3	3	7	13	7			
335-56 - 338-56	300										
338-56 - 358-06	130										
358-06 - 361-06	300										
361-06 - 393-56	130										
393-56 - 411-56	300			5		5					
411-56 - 424-36	160										
424-36 - 555-36	100			2	2	80	49	15			
555-36 - 708-36	300					25	26				
MAINLINE - WESTBOUND											
24-00 - 46-00	100	12	12								24
46-00 - 55-00	300										
55-00 - 124-00	100			3		17	42	19			
124-00 - 138-40	120										
138-40 - 151-20	160			2							
151-20 - 166-20	300										
166-20 - 196-10	130			6	6	6	6	4	1		
196-10 - 230-10	100			7	14	7	19	12			
230-10 - 236-10	300										
236-10 - 266-10	100			7	7	18	3	6			
266-10 - 272-10 RT	300					2					
E.O. 272-99.02 BK - 271-14-95											
SUB-TOTAL		53	26	74	90	260	352	107			79

LOCATION	QUANTITY												
	SPACING	66194-002		66193-001		66193-001		66193-001		66193-001		66193-001	
		XS-1Y (PER TET-S) 3"X3"	TYPE-B-1 (PER TET-S) 4"X4"	CLASO-1 (PER TET-S) 4"X4"	CLASO-1 (PER TET-S) 4"X4"	CLASO-1 (PER TET-S) 4"X4"	CLASO-1 (PER TET-S) 4"X4"	CLASO-1 (PER TET-S) 4"X4"	CLASO-1 (PER TET-S) 4"X4"	CLASO-1 (PER TET-S) 4"X4"	CLASO-1 (PER TET-S) 4"X4"	CLASO-1 (PER TET-S) 4"X4"	
MAINLINE - WESTBOUND (CONT'D)													
271-85 - 291-05	160												
291-05 - 303-05	300												
303-05 - 335-55	130												
335-55 - 338-55	300												
338-55 - 359-05	130												
359-05 - 361-05	300												
361-05 - 393-55	130												
393-55 - 417-55	300												
417-55 - 427-15	160												
427-15 - 558-15	100												
558-15 - 639-15	300												
639-15 - 684-15	100												
684-15 - 708-15	300												
EXIT 1B - RAMP A													
24-50 - 29-50	100	2	2										
29-50 - 31-30	60	3	3										
31-30 - 34-30	100	3											
35-85 - 42-85	100												
EXIT 1B - RAMP B													
233-20 - 241-20	60	6											
241-20 - 246-20	100												
EXIT 1B - RAMP C													
241-25 - 246-25	100	3	4										
246-25 - 248-05	60	3	3										
248-05 - 252-05	40	10											
252-05 - 253-85	60	3	3										
EXIT 1B - RAMP D													
28-00 - 35-00	100	2	7										
35-00 - 44-00	60												
44-00 - 46-00	100												
EXIT 2A - RAMP A													
58-00 - 64-00	100												
64-00 - 66-50	50												
66-50 - 70-50	100												
EXIT 2A - RAMP B													
67-00 - 68-00	100												
68-00 - 72-40	20												
72-40 - 74-40	100												
74-40 - 77-20	70												
77-20 - 78-20	100												
SUB-TOTAL		25	32	6	5	142	10	195	41				
SUB-TOTAL COL 1		53	26	74	90	260	352	107					
TOTAL THIS SHEET		78	58	80	95	402	547	148					

SEE SHEET XX FOR GUARDRAIL MOUNTED FLEXIBLE DELINEATOR POST DETAILS.
 ALL SOIL ANCHORED GUARDRAIL MOUNTED DELINEATORS SHALL UTILIZE TYPE "A" BRACKET DETAILS.
 SEE SHEET XX FOR TYPE "A" BRACKET DETAILS.
 ALL SOIL ANCHORED GUARDRAIL MOUNTED DELINEATORS SHALL UTILIZE TYPE "B" M.I.D. SHEETING AND SHALL BE 8" M.I.D. DELINEATORS SHALL UTILIZE TYPE "A" BRACKET DETAILS.
 THE WEST VIRGINIA DEPARTMENT OF TRANSPORTATION
 DIVISION OF HIGHWAYS
 I-70 SIGN RENOVATION
 COUNTY: WEST VIRGINIA

PLAN SHEET

DRAWN	CHECKED	APPROVED	DATE

NO SCALE

REVISION NUMBER	DATE	BY	REVISION

DELINEATOR ESTIMATE OF QUANTITIES

FIGURE 49
 DELINEATOR ESTIMATE OF QUANTITIES

Index

- AASHTO, 2, 99
- AD2-1, 51, 53, 64
- AD2-2, 4, 51, 76
- AD5-5, 4, 49, 50, 61, 74
- ADT, 6, 3, 48, 51, 52, 59, 61, 73, 89, 91
- AE1-4A, 2, 49, 50, 51
- AE2-1, 3, 59, 60, 71
- AE2-2, 3, 59, 60, 71
- AE2-4A, 50
- AE3-1, 3, 59, 60, 69
- AE3-2, 3, 59, 60, 69
- AE5-1, 2, 48, 76
- AE6-1, 3, 4, 60, 71, 72, 76
- ALL TRAFFIC, 32
- ALL WAY, 12
- Authorized Vehicle Crossovers, 1, 9, 21
- BEGIN CENTER LANE LEFT TURN ONLY, 17
- Bicycle lanes, 41
- BRAKE CHECK AREA, 24
- Byway or Backway, 53
- CENTER LANE LEFT TURN ONLY, 17
- Check Print Review, 3, 5
- Conventional roads, 2
- CROSS ROAD WARNING, 27
- CROSSING, 40, 93
- CURVE WARNING, 28, 32
- D1, 2, 4, 46, 48, 49, 51, 61, 64, 75, 106
- D10-1CR, 4, 83
- D10-1FR, 4, 83
- D10C, 4, 83
- D10F, 4, 83
- D11-1, 2, 41
- D11-1A, 2, 41
- D11-1B, 2, 41
- D1-2, 46, 48, 49, 51, 61, 75
- D1-3, 2, 46, 52
- D16-1, 2, 48, 99
- D16-2, 99
- D17-2, 9
- D2, 2, 4, 27, 46, 48, 61, 64, 71, 73, 106
- D2-1 or 2, 27
- D2-3, 2, 48
- D-24, 3, 53
- D-24A, 3, 53
- D27, 3, 53
- D4-2, 5, 91
- D5-1, 4, 77
- D5-13, 1, 24
- D5-14, 1, 24
- D5-1A, 4, 77
- D5-1B, 4, 77
- D5-2, 4, 77
- D5-6, 4, 77, 80
- D8-1, 4, 80
- D8-3, 4, 80
- D9-15, 77
- D9-2, 77
- Delineation, 5, 7, 1, 28, 96
- Design Guide for Signing, 1, 2
- DIVIDED HIGHWAY, 12, 32, 64
- Division of Highways, 2, 3, 42, 52, 69, 92, 99, 103
- DO NOT ENTER, 6, 12
- DOH, 3, 4, 48, 53, 103, 104, 105
- Downgrades, 2, 6, 32
- E13-1P, 29
- E1-5P, 4, 84
- E5-1A, 3, 29, 71
- emergency stopping, 7
- END CENTER LANE LEFT TURN ONLY, 17
- entrance ramps, 21, 83, 87
- Exit Gore, 3, 29, 71
- exit ramps, 12, 24, 28, 29, 30, 49, 50, 60, 69, 74, 75, 83, 84, 96
- expressway, 2, 3, 9, 12, 17, 29, 32, 49, 50, 59, 60, 61, 64, 69, 72, 73, 74, 75, 76, 80, 84, 89, 92, 96
- Fabrication Manual, 2, 6, 26, 71
- FHWA, 26
- Final Field Review, 3, 4
- FISH HOOK LANE CONTROL, 21
- Four-lane highways with design speeds, 2
- freeway, 2, 9, 12, 21, 28, 29, 30, 32, 33, 49, 50, 51, 54, 59, 60, 69, 71, 72, 73, 74, 76, 77, 80, 83, 84, 89, 102
- Fully controlled access, 2
- General Signing, 1, 6
- gore, 30, 60, 69, 71, 77, 80, 83, 99
- GPS, 4, 5, 107
- guide signs, 1, 4, 42, 46, 49, 51, 54, 60, 69, 74, 80, 84, 104, 105, 106
- Guide signs, 1, 42, 106
- GVWR, 7, 24
- Horizontal Alignment, 1, 6, 7, 28, 29
- I2 or I2A, 87
- I-25, 4, 89
- I27, 4, 87, 89
- I27A, 4, 87, 89
- I-33, 52, 53
- I-35, 52
- I-5, 52
- I-50A, 4, 91
- I-5B, 52
- I-7, 52
- I-8, 52
- interchange, 3, 5, 6, 43, 49, 50, 54, 59, 60, 69, 71, 72, 73, 74, 75, 76, 77, 83, 84, 87, 98

- intersection, 3, 6, 12, 17, 21, 24, 27, 42, 43, 46, 48, 49, 51, 52, 53, 60, 61, 64, 72, 73, 75, 76, 87, 91, 106
- Intersection Signs, 4, 6, 72
- Interstate, 5, 3, 5, 42, 43, 46, 54, 83, 87, 89, 92, 106
- interstate highway, 2
- Interstate Mainline, 3
- inventory plan, 3
- Junction Assembly, 2, 43, 46, 49, 50, 51, 64
- KEEP LEFT, 12
- KEEP RIGHT, 9, 12, 24, 32
- Lane control signing, 21
- LEFT LANE MUST TURN LEFT, 21
- LEFT LANE NO TRUCKS, 1, 9
- LOGO, 5, 3, 76, 92, 105
- LOW CLEARANCE, 40
- M1, 2, 42, 43, 46, 49, 50, 87
- M1-1, 2, 42, 43, 46, 50
- M1-4, 2, 42, 43, 50
- M1-6, 2, 42, 43, 50
- M2-1, 2, 43, 50
- M3-1, 2, 42
- M3-4, 2, 42
- M4-1a, 43
- M4-2, 43
- M4-4, 43
- M4-5, 43
- M4-6, 43
- M5-3R, 24
- M8-1, 4, 49, 51, 76
- Mandatory Truck Brake Check Areas, 1, 24
- mph, 6, 9, 12, 27, 40, 42, 49, 51, 93, 106
- ms consultants, inc.**, 1
- MSE, 3
- multi-lane roundabout, 21
- MUTCD, 2, 6, 21, 26, 28, 30, 41, 69, 83
- NO LEFT TURN, 17
- NO OVERNIGHT PARKING, 21
- No Parking Signs, 1, 24
- NO RIGHT TURN, 17
- NO U TURN, 9
- OBJECT MARKER, 17
- Object markers, 9, 41
- Office Review, 3, 5, 103
- ONE WAY, 12
- park and ride, 21, 91
- Partially controlled access, 2
- Post Interchange, 4, 6, 72, 73
- Preliminary Field Review, 3, 4
- preparation of sign plans, 3
- preparation of signing plans, 2
- PROHIBITED ON FREEWAY, 21
- PS & E Review, 3
- R1-1, 1, 12, 17, 21, 29, 99
- R1-10P, 1, 12, 21
- R1-12, 1, 12, 21
- R1-13, 1, 12
- R1-2, 1, 12, 21, 99
- R13-2A, 1, 24
- R13-2B, 1, 24
- R13-2C, 1, 24
- R1-4, 1, 12
- R2-1 sign, 6, 72, 73, 102
- R2-8, 6, 87, 89
- R3-1, 1, 17, 21
- R3-17, 2, 41
- R3-17A, 2, 41
- R3-17B, 2, 41
- R3-2, 1, 17, 21
- R3-2R, 1, 12
- R3-3, 1, 21
- R3-4, 1, 9, 21
- R3-5, 1, 21
- R3-5A, 1, 21
- R3-7L, 1, 21
- R3-7R, 1, 21
- R3-8, 1, 21
- R3-9B, 1, 17
- R3-9C, 1, 17
- R3-9E, 1, 17
- R4-1, 2, 32
- R4-14R, 32
- R4-3, 1, 9
- R4-5A, 1, 9
- R4-5B, 1, 9
- R4-5C, 1, 9
- R4-6, 1, 9
- R4-7, 1, 12, 17
- R4-7A, 2, 32
- R4-7C, 2, 32
- R4-8, 1, 12, 17
- R5-1, 1, 12, 17
- R5-1A, 1, 12, 17
- R5-5F, 1, 21
- R6-1, 1, 12, 17
- R6-1L, 17
- R6-1R, 17
- R6-3, 1, 12, 64
- R6-3A, 1, 12, 64
- R6-4A, 1, 21
- R6-4B, 1, 21
- R8-11A, 1, 21
- R8-12, 1, 9
- R8-3A, 1, 24, 80
- R8-7, 1, 4, 7, 73, 87
- RADAR, 6, 87, 89
- RADAR ENFORCED, 6, 87, 89
- Railroad Crossing Warning Signs, 41
- Regulatory signs for expressway intersections, 12
- REST AREA, 21, 77, 80
- RIGHT LANE MUST TURN RIGHT, 21

RIGHT TURN ONLY, 12
ROAD CLOSED, 32
Roadside Design Guide, 2
roundabout, 21
ROUNABOUT DIRECTIONAL ARROW, 21
Route Sign, 2, 42, 43, 46, 49, 51, 76
S1-1, 93, 96
S1-1B, 93
S1-1C, 93
S3-1, 27, 96
S3-5, 96
S4-2, 93
S4-3A, 93
S4-4, 93
S4-5, 93
SIDE ROAD, 27
Sign Fabrication Manual, 26
signing plans, 1, 2
Speed Limit, 1, 4, 6, 61, 64, 72
Standard Specifications, 2, 4, 69, 99, 103, 104
STOP, 6, 12, 17, 24, 27, 64, 96
TE1-3A, 4, 103
TE1-3B, 4, 102
TE1-3C, 4, 103, 104
TE1-5A, 104
TE1-7, 102
TO ONCOMING TRAFFIC, 1, 12
TODS, 5, 3, 76, 91, 92, 105
Traffic Engineering Directives, 2, 105
Traffic Engineering Division, 1, 5, 7, 24, 40, 41, 53, 73, 89, 105, 107
truck climbing lane, 9, 30
Two-lane highways with design speeds, 2
Two-Way Left Turn Only, 1, 17
UTM, 107
U-turn, 21
Volume 2, 2, 98, 104
W10-1, 41
W10-2, 41
W10-3, 41
W10-4, 41
W10-5, 41
W1-1, 28, 102
W11-1, 2, 40, 41
W11-10, 27, 40
W11-11, 40
W11-12, 40, 53
W11-1A, 2, 41
W11-2, 40
W11-3, 2, 40
W11-4, 40
W11-5, 40
W11-7, 40
W11-7A, 40
W1-2, 28
W12-2, 2, 40
W12-2P, 2, 40
W13-1, 28, 29
W13-2, 1, 29
W13-3, 1, 29
W1-6, 28, 30
W16-7, 53
W16-8P, 27, 64
W17-8, 2, 32
W17-9, 2, 32
W17-9A, 2, 32
W1-8, 1, 30
W2-1, 1, 27, 64
W2-1F, 2, 33
W2-2, 1, 27, 64
W3-1, 1, 27, 29
W3-3, 2, 30, 33
W3-3F, 2, 33
W3-5, 6
W4-1, 2, 30
W4-2L, 2, 32
W4-2R or L, 2, 30
W5-6, 33, 40
W5-7, 2, 32, 40, 53
W5-7A, 2, 32
W5-8A, 9
W5-8B, 9
W7-1B, 2, 4, 32, 33, 40, 80
W7-2, 2, 32
W7-3A, 2, 32, 33, 40
W7-4, 4, 80
W7-4A, 4, 80
W7-4B, 4, 80
W8-14, 1, 28
W9-1R or L, 2, 30
Warning signs, 26, 27
WATCH FOR ICE ON BRIDGE, 28
West Virginia Division of Highways, 1, 2
West Virginia Division of Highways Sign Fabrication Details, 2
West Virginia Standard Specifications for Roads and Bridges, 2
WRONG WAY, 6, 12
WVDOH, 1
XR-3, 9, 17
XS-15, 2, 41
XS-2, 2, 41
XS-2L, 41
XS-2R, 41
YIELD, 6, 12, 21, 27

APPENDIX A

Sign Design Guidelines

Sign Design Guidelines

Many styles for the most common guide sign types have been developed for use within GuidSIGN (See the listing of styles on pages A-53 & A-54). For the sign types without a style or template provided, the designer can create them using the following guidelines. These guidelines shall also be used when designing signs without the use of design software.

After determining the appropriate legend size using Tables 1 or 2, the proper font must be determined using the following guidance:

- Mixed case legend shall be Series E Modified 2000 (EM);
- Destinations, road names and exit names shall be mixed case;
- Cardinal words (NORTH, SOUTH, etc.), JCT and TO shall be all capital letters using Series E;
- Distance or action messages (1 MILE, NEXT RIGHT, NEXT LEFT, USE EXIT X, etc.) shall be all capital letters using Series E;
- All Exit Panels (word & numbers/letters) shall be all capital letters using Series E;
- Destinations outside of West Virginia – Destination shall be mixed case and the two letter state abbreviation (OH, VA, MD, KY, and PA) shall be all capital letters in Series E;
- Mileage signs – Destination shall be mixed case and the mileage numeral shall be Series E;
- Sequence Signs – City names and exit names shall be mixed case; the word EXITS shall be all capital letters using Series E, whole number shall be Series E and fraction shall be Series EM;
- “29th Street” -- “29” shall be Series E and the rest shall be in mixed case;
- “US 19”, “I-79”, etc. shall be all Series E;
- Any symbol like “&” or “\$” shall be Series E;
- All LOGO/TODS shall be all capital letters using Series E (GAS, FOOD, ATTRACTIONS, etc.);
- Use Series B, C, D, or E on 24”x24” or 30”x30” supplemental destination plaques (green, blue, or brown backgrounds);

For any sign legends not listed, contact Traffic Engineering Division.

The next step is to determine the appropriate arrow size (Table 3) and shield size (Tables 1 and 2) if applicable. Then length and height of the sign should be calculated using an approved sign design software such as GuidSIGN. Common designs are shown in the Example Sign Layouts at the end of this section, and styles for use in GuidSIGN are available from Traffic Engineering Division and the WVDOH website.

GuidSIGN uses styles to set parameters such as border width, corner radius, margins, object spacing, text sizes, etc. Note that some of the parameters set in a style can be modified while creating a sign. Others, such as border width and radii, cannot. Once created, these styles can speed up the process of generating fabrication details for inclusion in construction plans. Due to the large number of possible combinations for the most often used signs types, not all possible styles are available from Traffic Engineering Division, so the designer is encouraged to create styles, provided they are in line with the guidance given in this section.

Appendix A – Sign Design Guidelines

Table 1

Letter, Numeral, Etc. Sizes for Guide Signs Used at INTERCHANGES

A. Advance Guide, Exit Direction and Overhead Signs

	<u>Freeway Junction</u>	<u>Major Interchange</u>	<u>Intermediate & Expressway Interchange</u>	<u>All Overheads</u>
Exit Panel				
Word	10" E	10" E	10" E	10" E
Numeral	15" E	15" E	15" E	15" E
Letter	15" E	15" E	15" E	15" E
Route Marker Shield				
1 or 2 Digit	48" x 48"	36" x 36"	36" x 36"	36" x 36"
3 Digit	60" x 48"	45" x 36"	45" x 36"	45" x 36"
Cardinal				
First Letter	18" E	18" E	15" E	15" E
Remaining Letters	15" E	15" E	12" E	12" E
Destination				
Word	20"/15" EM	20"/15" EM	16"/12" EM	16"/12" EM
Numbers & Symbols	20"E	20"E	16"E	16"E
Distance				
Numeral	18" E	18" E	15" E	15" E
Single Char. Fraction	18" E	18" E	15" E	15" E
Word	12" E	12" E	10" E	10" E
Arrow				
60° Angle	22.3" x 35.6"	22.3" x 35.6"	22.3" x 35.6"	22.3" x 35.6"
Up	21.9" x 25"	21.9" x 25"	21.9" x 25"	21.9" x 25"
Down	22" x 32"	22" x 32"	22" x 32"	22" x 32"

When sign widths exceed 25 feet, consideration should be given to reducing legend size from recommended size to the next smaller size.

Reduction of legend size shall also be considered where there is restricted roadway width and on overhead sign structures where excessive sign widths create structural or lane control problems.

Appendix A – Sign Design Guidelines

Table 1 (continued)

B. Supplemental Guide Signs

Destination	13.3"/10" EM
Exit Panel	Standard E1-5
Action Message	10" E
Exit Number	15" E

C. Sequence Signs (Freeway Ground Mnt. and All Overhead)

City	13.3"/10" EM
"EXITS"	13.3" E
Exit Name	13.3"/10" EM
Distance Numeral	13.3" E
Single Char. Fraction	13.3"/10" EM

Sequence Signs (Expressway Ground Mnt. Only)

City	10.6"/8" EM
"EXITS"	10.6" E
Exit Name	10.6"/8" EM
Distance Numeral	10.6" E
Single Char. Fraction	10.6"/8" EM

D. Mileage Signs

Destination	8"/6" EM
Distance Numeral	8" E

E. Boundary and Orientation Signs

County, River, or Creek, etc. Name	8"/6" EM
"CERTIFIED BUSINESS LOCATION"	6" D

F. EXIT ONLY

Words	12" E
Down Arrow	22" x 32"
45° Arrow	22.3" x 35.6"

Appendix A – Sign Design Guidelines

Table 2

Letter, Numeral, Etc. Sizes for Guide Signs On Mainline Expressway at INTERSECTIONS, Interchange Ramps and Crossroads, and Two Lane Highways.

	Mainline Expressway	Interchange Ramp or Crossroad	Two Lane Highway
A. Destination Signs			
Destination Arrow	8"/6" EM 12.8" x 11.3"	8"/6" EM 12.8" x 11.3"	8"/6" EM 9.6" x 8.4"
B. Mileage Signs			
Destination Numeral	8"/6" EM 8" E	8"/6" EM 8" E	8"/6" EM 6" E
C. Ramp Entrance Signs			
Route Marker			
1 or 2 Digit	N/A	24" x 24"	N/A
3 Digit	N/A	30" x 24"	N/A
Cardinal			
First Letter	N/A	10" E	N/A
Remaining Letters	N/A	8" E	N/A
Destination Arrow	N/A N/A	8"/6" EM 24.3 x 15.1"	N/A N/A
D. Junction Marker and Trailblazing Guide Signs			
"JCT", "TO"	8" E	8" E	N/A
Route Marker			
1 or 2 Digit	36" x 36"	36" x 36"	N/A
3 Digit	45" x 36"	45" x 36"	N/A
Distance Numeral	12" E	12" E	N/A
Single Char. Fraction	12" E	12" E	N/A
Distance Unit	8" E	8" E	N/A
Cardinal			
First Letter	10" E	10" E	N/A
Remaining Letters	8" E	8" E	N/A









Appendix A – Sign Design Guidelines

Table 2 (continued)

	<u>Mainline Expressway</u>	<u>Interchange Ramp or Crossroad</u>	<u>Two Lane Highway</u>
E. Advance Intersection Signs			
Destination	10.6"/8" EM	N/A	N/A
Action Message			
Words	8" E	N/A	N/A
Single Char. Fraction	12" E	N/A	N/A
Route Marker	12" Diameter	N/A	N/A
F. Intersection Direction Signs			
Road Name	8"/6" EM	N/A	N/A
Arrow			
Single Head	12.8 x 11.3	N/A	N/A
Double Head	30" x 10"	N/A	N/A
Route Marker	12" Diameter	N/A	N/A
G. County Road Signs			
Road Name	N/A	N/A	3"/2.25" EM
Arrow			
Single Head	N/A	N/A	4.5" x 4"
Double Headed	N/A	N/A	12" x 4"
Shield	N/A	N/A	6" Diameter
H. Supplemental Signs			
Destination	10.6"/8" EM	N/A	N/A
Action Message	8" E	N/A	N/A
I. Sequence Signs (Expressway Ground Mnt. Only, Intersections Only)			
City	10.6"/8" EM	N/A	N/A
Exit Name	10.6"/8" EM	N/A	N/A
Distance Numeral	10.6" E	N/A	N/A
Single Char. Fraction	10.6"/8" EM	N/A	N/A
J. Boundary and Orientation Signs			
County, River, or Creek, etc. Name	6"/4.5" EM	6"/4.5" EM	4"/3" EM
"CERTIFIED BUSINESS LOCATION"	6" D	5" D	3" D
K. Overhead Signs - See Table 1			

Appendix A – Sign Design Guidelines

Table 3

GUIDE SIGN ARROW & SHIELD SIZE BASED ON LEGEND SIZE														
LEGEND SIZE	HORIZONTAL		DBL HD *		45 DEGREE		60 DEGREE		UP		DOWN		County Route Shield	
														
	L	W	L	W	A	L	A	L	L	W	L	W	L	W
3"/2.25" EM	4.5	4	12	4	3.8	4.5			4.5	4				6
4"/3" EM	6.4	5.6	18	6	5.3	6.4			6.4	5.6				8
6"/4.5" EM	9.6	8.4	24	8	8	9.6			9.6	8.4				9
8"/6" EM	12.8	11.3	30	10	10.5	12.8			12.8	11.3				12
10.6"/8" EM	24.3	15.1	36	12			15.5	24.3	17.3	14.5				12
13.3"/10" EM	29.3	18.3					18.5	29.3	20.3	17.5	16.5	24		
16"/12" EM & 20"/15" EM	35.6	22.3			20.3	25.0	22.6	35.6	25	21.9	22	32		
Ramp Logo Signs Straight Shaft Arrow	12	8			9.5	12			12	8				

EM = Mixed Case Series E Modified W = Fork Width L = Length
All dimensions are in inches.

Note: GUIDSIGN arrows will not necessarily match dimensions in the chart; however every effort should be made to approximate the dimensions shown here.

* Double headed arrow shall be made by placing two straight shaft arrows end to end. The length of each arrow is 1/2 L. Fork width (W) shall be as shown in chart.

Appendix A – Sign Design Guidelines

Table 4

Sign Border, Border Inset and Corner Radii for non-standard signs.

Signs should be constructed using demountable copy on extruded panels when major lettering is 8" height or greater. All others should be made using direct applied copy on flat sheet material unless approved by Traffic Engineering Division.

Dark legend and border are to be used on signs with backgrounds which are white, yellow, fluorescent yellow, orange or fluorescent yellow green.

Light legend and border are to be used on signs with backgrounds which are green, blue, or brown.

Border widths and radii are determined using the "least dimension" of the sign length and height, whichever is shorter.

The following tables shall be used for all non-standard signs fabricated for the Traffic Engineering Division.

A. Flat Sheet Sign Material with Direct Applied Copy

Dark Legend and Border

<u>Least Dimension</u>	<u>Border Inset¹</u>	<u>Border Width</u>	<u>Border Corner Radius</u>
6" to 12"	0.38"	0.38"	1.12"
15" to 24"	0.38"	0.62"	1.12"
27" to 30"	0.50"	0.75"	1.38"
36" to 42"	0.62"	0.88"	1.62"
48" to 54"	0.75"	1.25"	2.25"
60" or more	1.00"	1.50"	2.75"

Light Legend and Border

<u>Least Dimension</u>	<u>Border Width</u>	<u>Border Corner Radius</u>
Up to 24"	0.5"	1.5"
30" to 36"	1"	3"
42" to 60"	1"	6"

¹ If a dark legend and border on a light background is part of a sign with light legend and border on a dark background, such as on a lane control sign:

- There will be no border inset;
- border width and radius shall match that of the dark background sign;
- and there will be no border where the two parts meet.

Appendix A – Sign Design Guidelines

Table 4 (Continued)

B. Extruded Panel Sign Material with Demountable Copy

Dark Legend and Border

<u>Least Dimension</u>	<u>Border Inset</u> ¹	<u>Border Width</u> ⁶	<u>Border Corner Radius</u>
Up to 60"		Use Table 4A for Border Sizing	
66" to 78"	1"	1.5"	3"
84" or more	1"	2"	6"

Light Legend and Border

<u>Least Dimension</u>	<u>Border Width</u>	<u>Border Corner Radius</u>
Up to 36"	1" ³	3"
42" to 54"	1" ³	6"
60" ⁴ to 84"	2"	9"
90" or more	3" ⁵	12"
Exit Panels ²	2"	3"

¹ If a dark legend and border on a light background is part of a sign with light legend and border on a dark background, such as on an EXIT ONLY sign:

There will be no border inset;
border width and radius shall match that of the dark background sign;
and there will be no border where the two parts meet.

² Border along top and sides only and 3" corner radius @ top left and top right corners

³ To be 2" if exit panel is used with the sign.

⁴ If ramp logo sign (LGR-X), border shall be 1" wide with a radius of 6".

⁵ To be 2" if major lettering is 10.6" or smaller.

⁶ Border width should not exceed stroke width of major copy on sign. See chart below.

Stroke Width of Standard Highway Alphabets

	4"	6"	8"	10"	12"	16"
Series B	0.52	0.78	1.04	1.3	1.56	2.08
Series C	0.56	0.84	1.12	1.4	1.68	2.24
Series D	0.64	0.96	1.28	1.6	1.92	2.56
Series E	0.72	1.08	1.44	1.8	2.16	2.88
Series EM	0.80	1.20	1.60	2.00	2.40	3.20

Rules for Sign Layout

1. The margins between the left and right vertical edges of the sign and the nearest legend of the longest line of copy should be equal to the height of the largest uppercase letter or numeral (does not include numerals within shields) on the sign. Note that the longest line of copy on some sign types (exit direction, intersection direction, sequence, and mileage signs in particular) may include arrows, shields or numerals from other lines of copy on the sign. Examples of various methods for determining the longest line of copy can be found in the Example Sign Layouts. In most cases, each remaining line of copy should be centered horizontally within the sign area; exit direction signs are one exception.
2. The margin from the top edge of sign to the nearest copy should be approximately equal to, but in no case less than one-half the average of the letter or numeral heights in the first line of copy.
3. The margin from the bottom edge of sign to the nearest copy should be approximately equal to, but in no case less than one-half the average of the letter or numeral heights in the last line of copy.
4. Vertical spacing between each item in the legend should be approximately three-fourths of the average of the heights of the capital or uppercase letters in the sign, but in no case shall the vertical spacing be less than one-half the average of adjacent lines of text. Care should be taken when setting vertical spacing with ascending or descending letters in adjacent lines.

See Figures A1-A3.

Spacing rules 1 through 4 above should be adjusted as necessary to ensure the final overall sign size meets the following criteria:

Extruded panel signs – height shall be in 12 inch increments, but may be in 6 inch increments on overheads with DT approval. Length shall be in 12 inch increments wherever practical, but may be in 6 inch increments.

Flat sheet signs – length and height shall be in 6 inch increments, except D16 series sign heights may be 9” and 15”.



Figure A1



Figure A2

Appendix A – Sign Design Guidelines

Note: GuidSIGN margins are calculated to the inside of the border. For example, if the horizontal margins should be approximately 16 inches and the sign has a border width of 3 inches then the GuidSIGN panel style should have the left and right margins set to 13 inches. This is also true for the top and bottom margins.



Figure A3



Figure A4

5. The horizontal word to word spacing for mixed case messages shall be equal to one and one-half times the lower case letter. See Figure A4. Note: To get the proper spacing when using GuidSIGN, set the text spacing between words to 1.125 x the smaller text height.
6. Horizontal spacing between words in all upper case letters using Series E fonts shall be equal to approximately one and one-half times the height of the letter, but in no case less than the height of the letter. See Figure A4.



Figure A5

7. Horizontal spacing between words in mixed case letters and numerals in a Distance (D2) sign or Sequence (AE6-1) sign shall be equal to one and one-half times the height of the upper case letter. See Figure A5.
8. Horizontal spacing between words in mixed case letters and an arrow on a Destination (D1) sign, or Intersection Direction (AD2) sign should be equal to the height of the upper case letter. See Figure A6.



Figure A6



Figure A7

Appendix A – Sign Design Guidelines

9. Horizontal spacing between words in mixed case letters and a shield on an Intersection Direction (AD2) sign or between an arrow and a shield should be equal to the height of the upper case letter. See Figure A7.
10. Horizontal spacing between a route shield and a cardinal word shall be equal to one-half the height of the shield. See Figure A8.
11. If two or more route markers are in the same line of text, they should be spaced from each other approximately equal to the distance of the widest shield, but in no case less than 12 inches. They may be spaced further apart so that the space between two cardinals above is no less than 18” or to achieve a more balanced appearance. The distance between them should be increased in 6 inch increments until the desired spacing is achieved. See Figure A9.
12. If two or more route markers are in the same line of text, they shall be centered in the sign horizontally. Where a cardinal word is used above a shield, the word shall be centered over the shield after the shield has been centered in the sign. Note that the left and right margins for the cardinal may not be the same. See Figure A9.

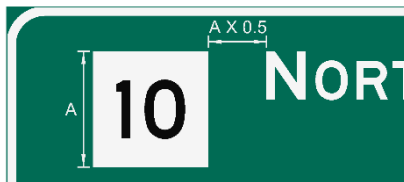

Figure A8

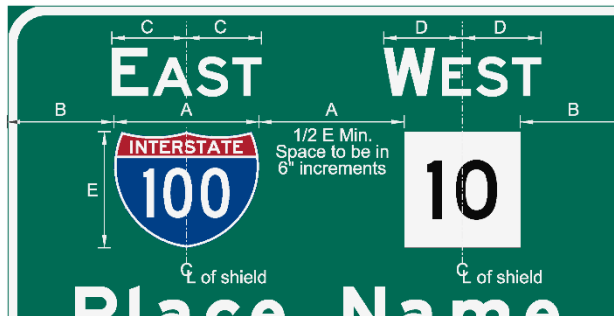

Figure A9

13. Horizontal spacing between a whole number and fraction shall be equal to three-fourths of the height of the whole number. See Figure A10.
14. Horizontal spacing between a fraction and distance unit shall be equal to the height of the whole number used with the fraction. See Figure A10.
15. All fractions shall be stacked and when placed using GuidSIGN shall use the “single-character fraction” option. See Figure A10.

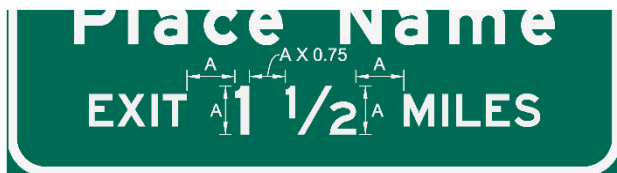

Figure A10



Figure A11

16. Horizontal spacing between words in mixed case letters and two letter state abbreviations shall be equal to the height of the upper case letter. See Figure A11.
17. Horizontal spacing between a single destination or the longer of two destinations and the 60 degree arrow on an exit direction sign (AE2-1) shall be a distance equal to the height of the capital letter of

Appendix A – Sign Design Guidelines

the destination. On exit direction signs with a single destination, the bottom of the arrow shall align vertically with the bottom of the destination text. See Figure A12. On exit direction signs with two destinations, the arrow shall align vertically with the center of both destinations. See Figure A13.

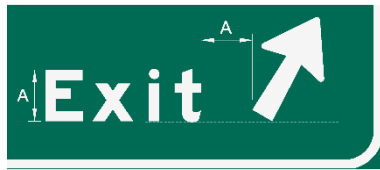

Figure A12

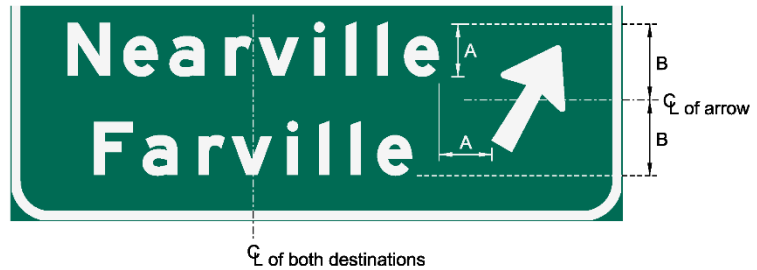

Figure A13

18. On exit direction signs, a single shield or a single shield with cardinal to the right shall be centered horizontally within the sign area. On exit direction signs with two destinations, the shorter length destination shall be centered horizontally with the longer length destination. See Figure A13.
19. On intersection direction signs or county road name signs with names/shields/arrows, the shield is always immediately to the right of the destination and any right facing arrow shall be to the right of the shield. See Figure A7.
20. On intersection direction signs with more than one destination, the destinations shall be ordered from top to bottom so that a straight ahead destination is first, then destinations to the left, then destinations to the right. Straight ahead and left facing arrows shall be placed to the extreme left of the destination name. Right facing arrows shall be placed to the extreme right of the destination name and shield, if applicable. See Figure A14.

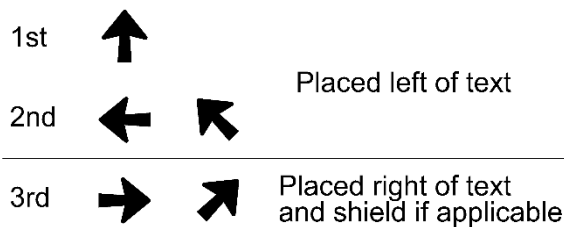

Figure A14

21. Distance information (EXIT 2 MILES, etc.) and action messages (NEXT RIGHT, USE EXIT 32, etc.) shall be centered horizontally in the sign area.
22. To determine the proper longest line of copy using GuidSIGN on sequence signs and mileage signs where the longest destination name is not on the same line as the longest distance number, follow the steps below. See Figure A15 for an example sign.

1. Select "Place Highway Text".
2. Create a line of text using the longest destination name plus the longest distance amount using "Name X".

Appendix A – Sign Design Guidelines

3. Go into "Advanced" to make sure the spaces between are correct.
4. Make a note of the string length then cancel the command.
5. Place a new line of text and go into "Advanced". Check the "Fix Length by:" box and set the string length to the distance noted previously. Select "Adjusting Word Gap".
6. Select "OK" and place the text into the sign.
7. Repeat steps 5 and 6 for each line of text.



Figure A15

If a sequence sign has a combination of distances with fractions and without, the whole numbers should be aligned on their right edges, See Figure A16. To place the text without a fraction properly, follow the steps above except in step 2 do not include the fraction or the space between the whole number and the fraction to determine the string length. Use that string length when placing the text.



Figure A16

Appendix A – Sign Design Guidelines

Example Sign Layouts

The next several pages contain example layouts for the most common signs found on the freeways, expressways and two-lane highways in West Virginia.

Sign Type	Sign Number	Page
Ramp Entrance	AE1-4	15-16
Exit Direction	AE2-1	17-20
Exit Only	AE4-4	21-23
Advance Exit	AE2-2, AE3-1, AE3-2	24-29
Pull Thru	AE1-5, AE2-5, AE3-4	30-32
Supplemental	AE5-1	33-35
Sequence	AE6-1	36-37
Advance Intersection	AD1-1, AD1-2	38
Directional	D1-1, D1-2, D1-3, AD2-1, AD2-2	39-43
Mileage	D2-1, D2-2, D2-3	44-45
County Road	D16-1, D16-2	46-47
Junction	AD5-5	48
Logo	LG Series, LGR Series	49-52

Appendix A – Sign Design Guidelines

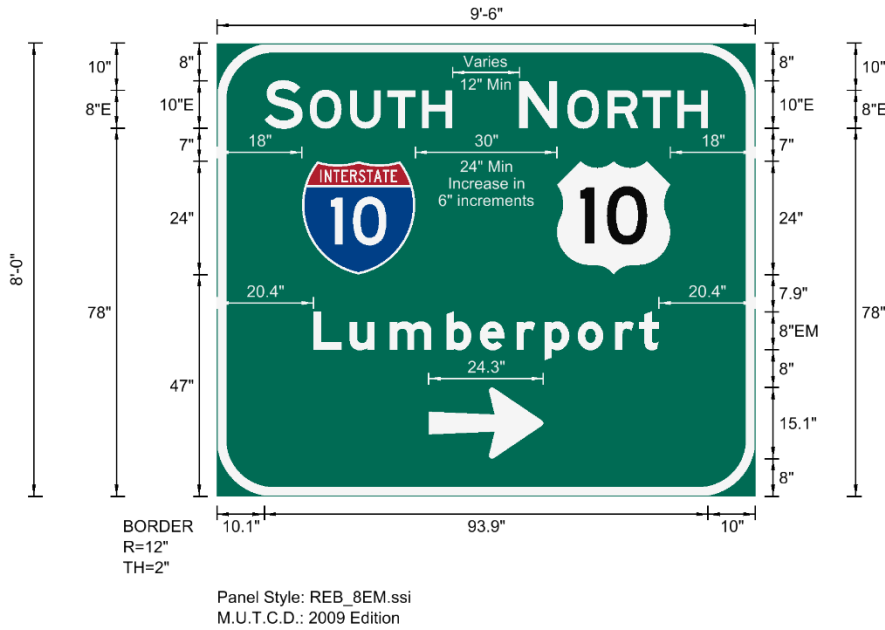

Longest Line of Copy
SOUTH NORTH
 Space

Ramp Entrance Signs
 Ground Mnt. (AE1-4)
 8" Mixed Case

Appendix A – Sign Design Guidelines



Ramp Entrance Signs
Overhead (AE1-4)
16" Mixed Case

Appendix A – Sign Design Guidelines

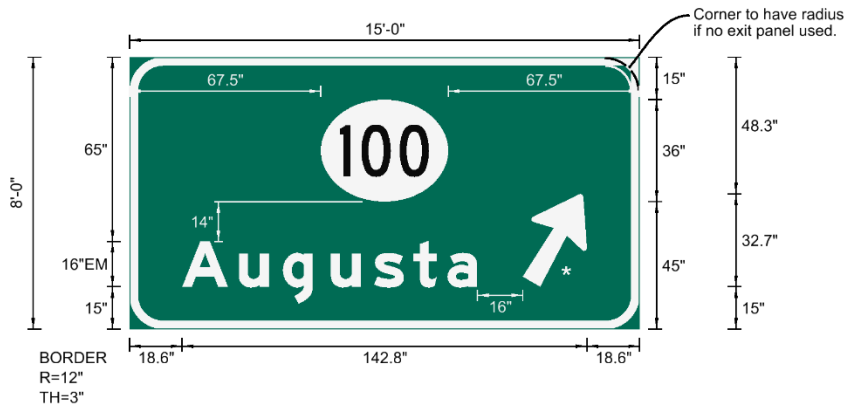

Panel Style: ED1A_16EM_FW.ssi
M.U.T.C.D.: 2009 Edition

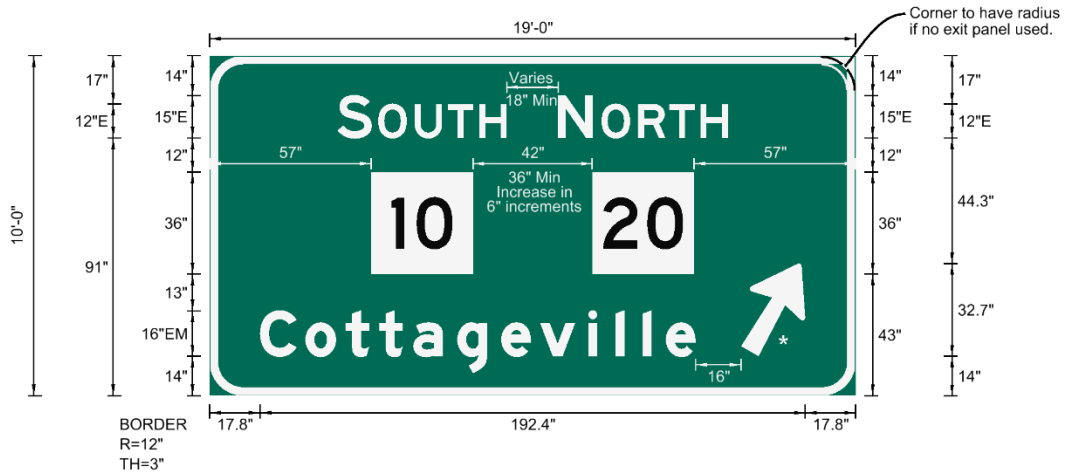

Panel Style: ED1B_16EM_FW.ssi
M.U.T.C.D.: 2009 Edition

Longest Line of Copy

Cottageville 

Exit Direction Signs (AE2-1)
16" Mixed Case
One Destination

* 22.3" x 35.6" arrow @ 60 degrees

Appendix A – Sign Design Guidelines

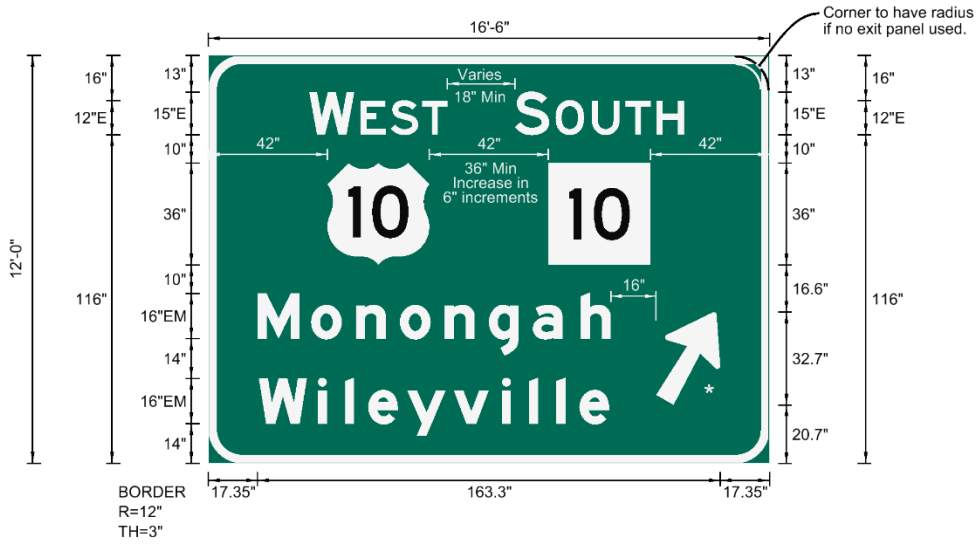
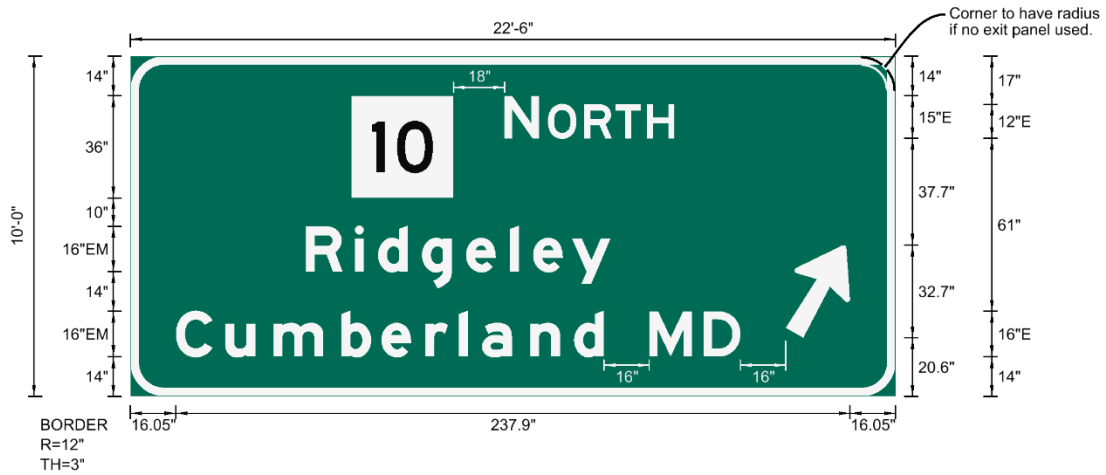

Longest Line of Copy
Monongah ↗

Exit Direction Signs (AE2-1)
16" Mixed Case
Two Destinations

* 22.3" x 35.6" arrow @ 60 degrees

Appendix A – Sign Design Guidelines

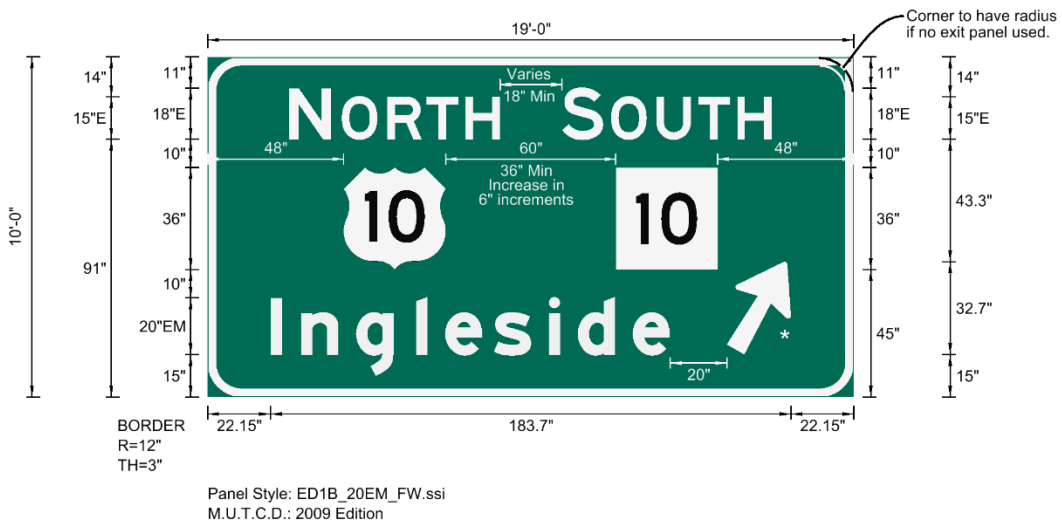

Exit Direction Signs (AE2-1)
20" Mixed Case
One Destination

* 22.3" x 35.6" arrow @ 60 degrees

Appendix A – Sign Design Guidelines

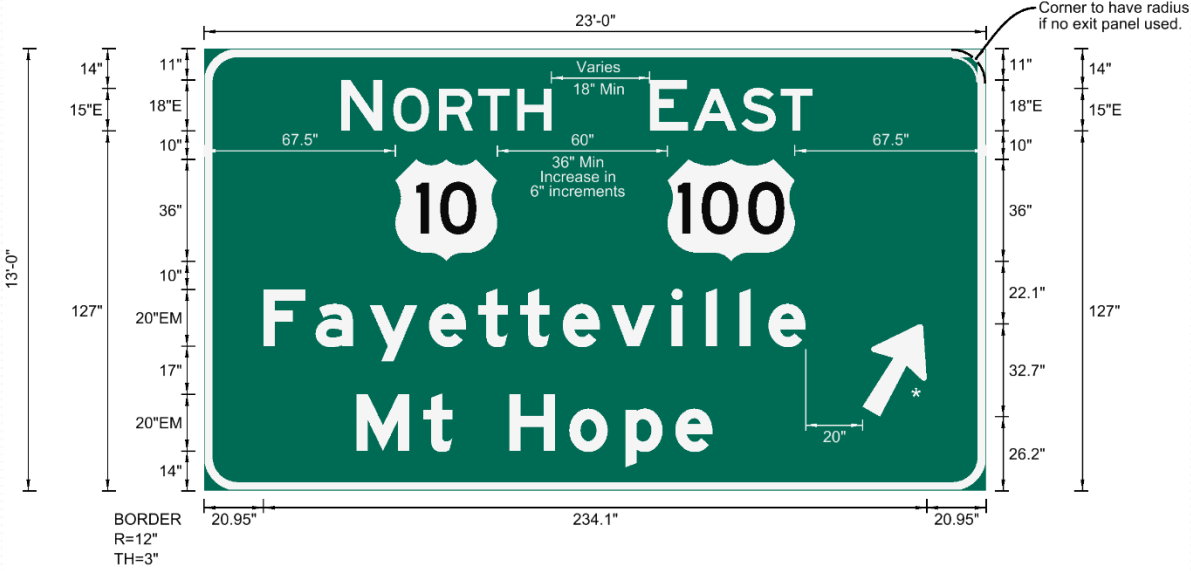
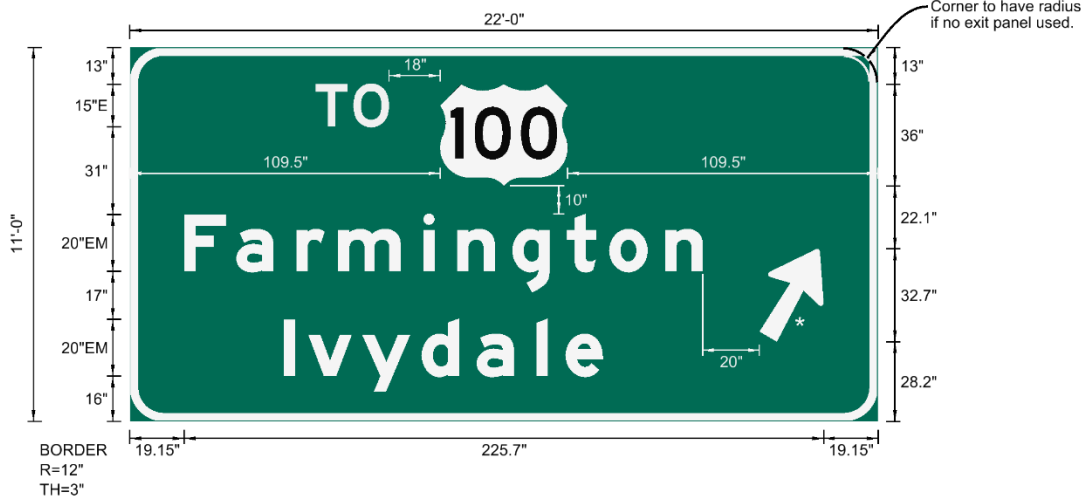

Exit Direction Signs (AE2-1)
20" Mixed Case
Two Destinations

* 22.3" x 35.6" arrow @ 60 degrees

Appendix A – Sign Design Guidelines

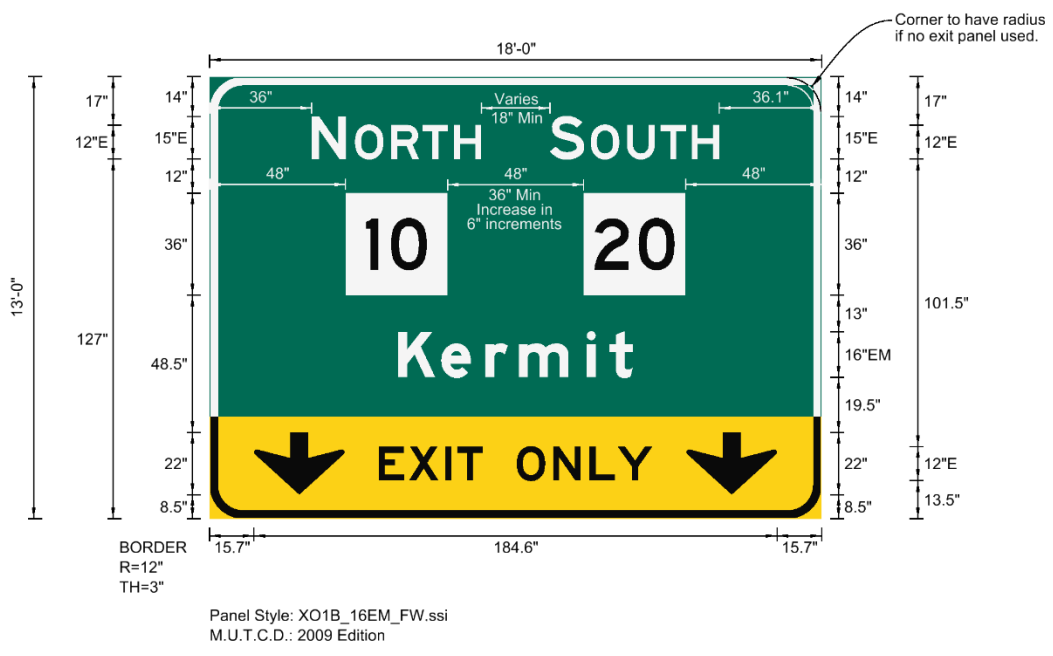
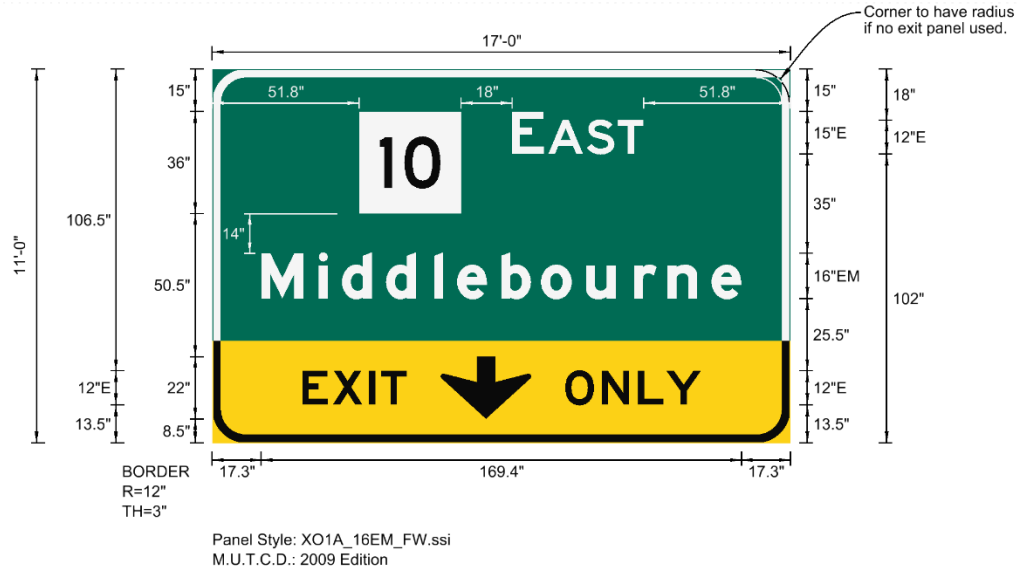

For EXIT ONLY signs that require distance information such as "1 MILE", vertical spacing for the green portion of the sign should be the same as shown in the examples for Advance Exit Signs with 16" mixed case legend. Distance information shall only be used with EXIT ONLY signs with one or two DOWN arrows.

EXIT ONLY Signs (AE4-4)
16" Mixed Case
One Destination

Appendix A – Sign Design Guidelines

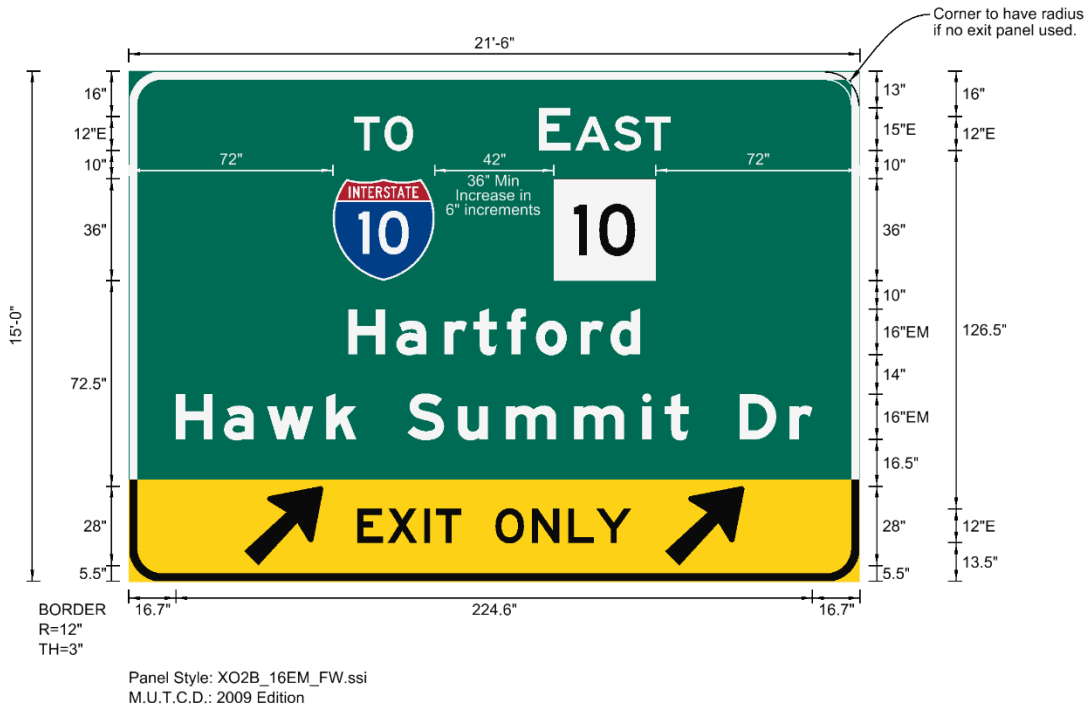
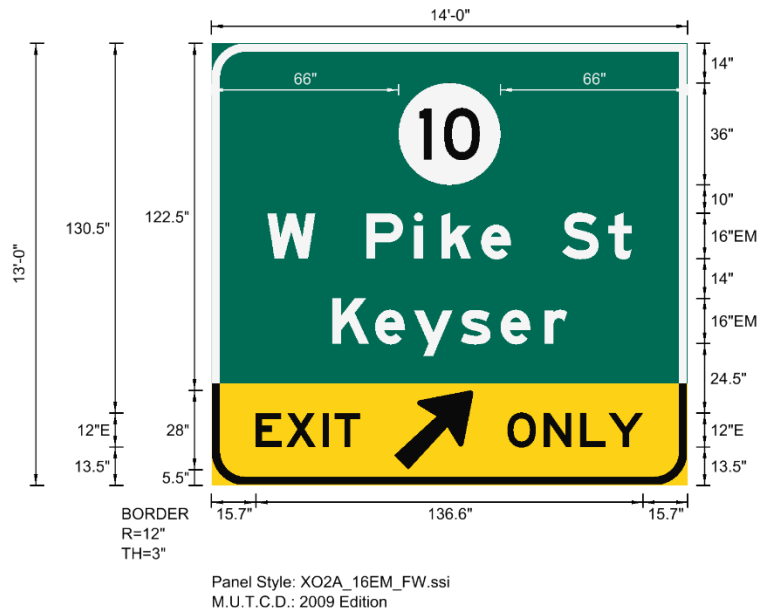

EXIT ONLY Signs (AE4-4)
16" Mixed Case
Two Destinations

Appendix A – Sign Design Guidelines

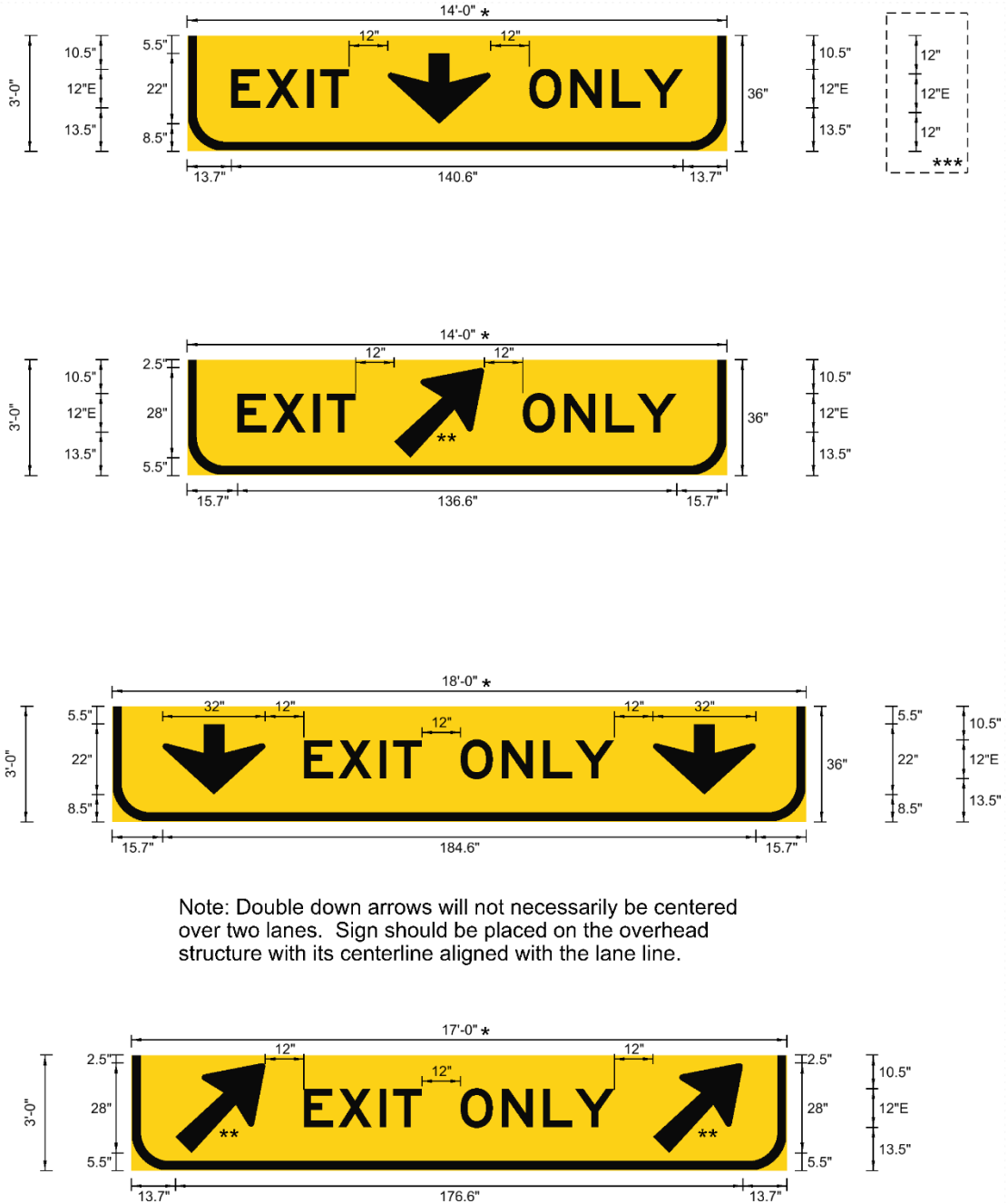

Note: Double down arrows will not necessarily be centered over two lanes. Sign should be placed on the overhead structure with its centerline aligned with the lane line.

- * Preferred minimum sign width. May be reduced if approved by Traffic Engineering Division.
- ** 22.3" x 35.6" arrow @ 45 degrees
- *** Alternate spacing of EXIT ONLY for all four types

EXIT ONLY Panels
Spacing Standards

Appendix A – Sign Design Guidelines

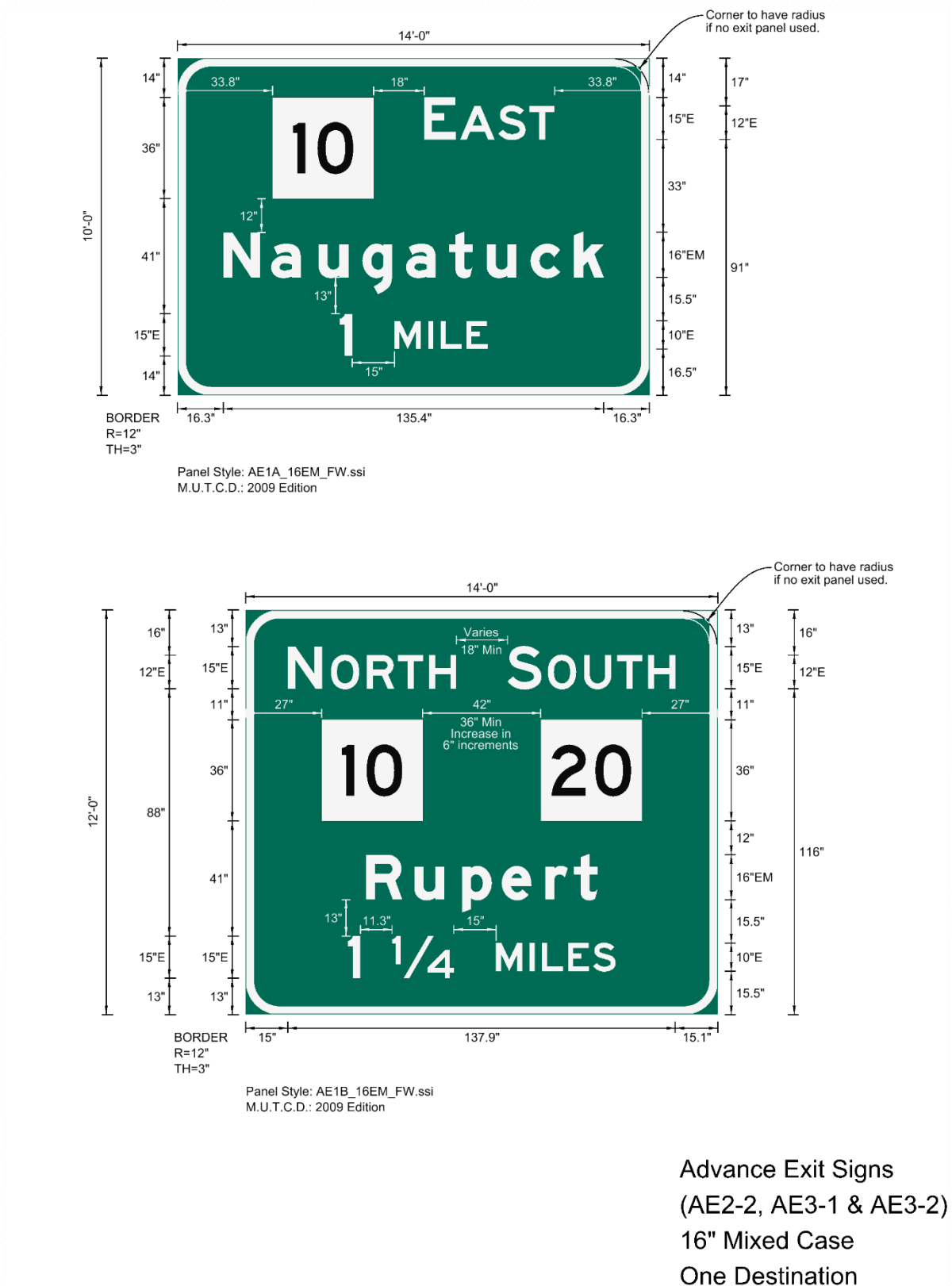

Appendix A – Sign Design Guidelines

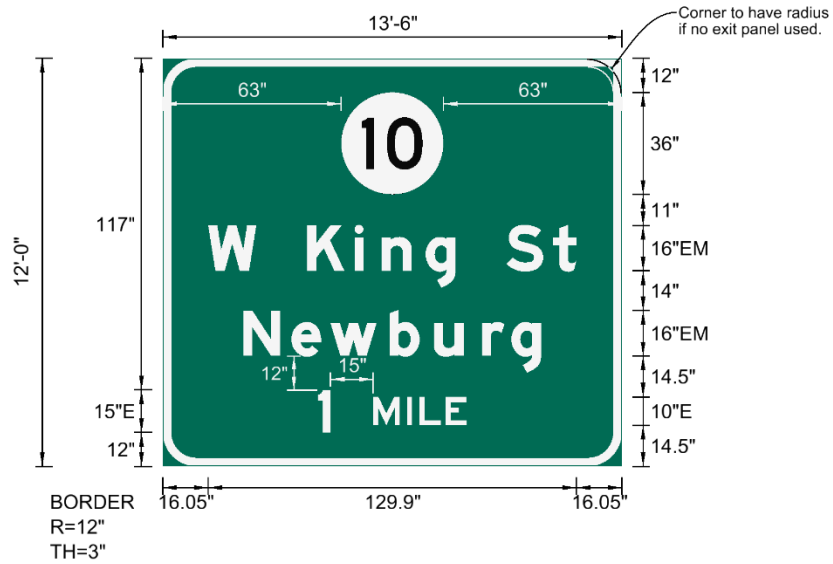

Panel Style: AE2A_16EM_FW.ssi
M.U.T.C.D.: 2009 Edition

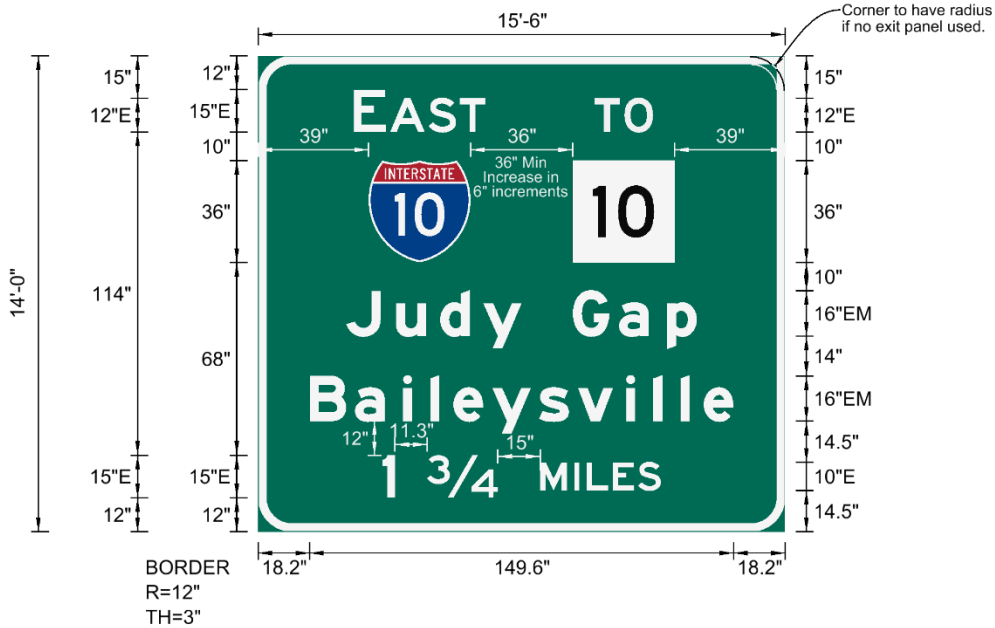

Panel Style: AE2B_16EM_FW.ssi
M.U.T.C.D.: 2009 Edition

Advance Exit Signs
(AE2-2, AE3-1 & AE3-2)
16" Mixed Case
Two Destinations

Appendix A – Sign Design Guidelines

For use when exit panel (E1-5) is used.



AE3-2



AE3-1

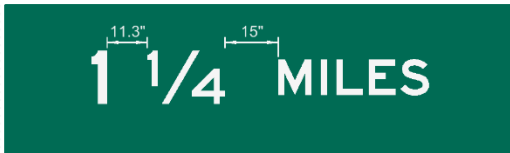

AE3-2

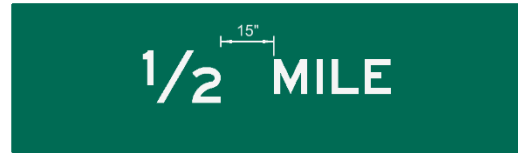

AE2-2

For use when no exit panel is used.

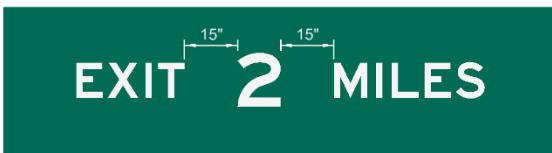

AE3-2

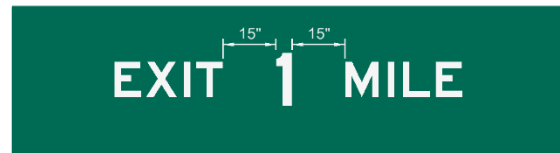

AE3-1

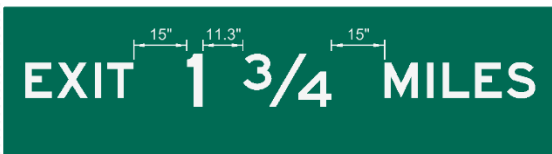

AE3-2

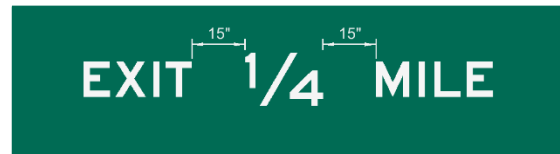

AE2-2

Advance Exit Signs
Spacing standards for exit
distances using 15"/10" E

Appendix A – Sign Design Guidelines

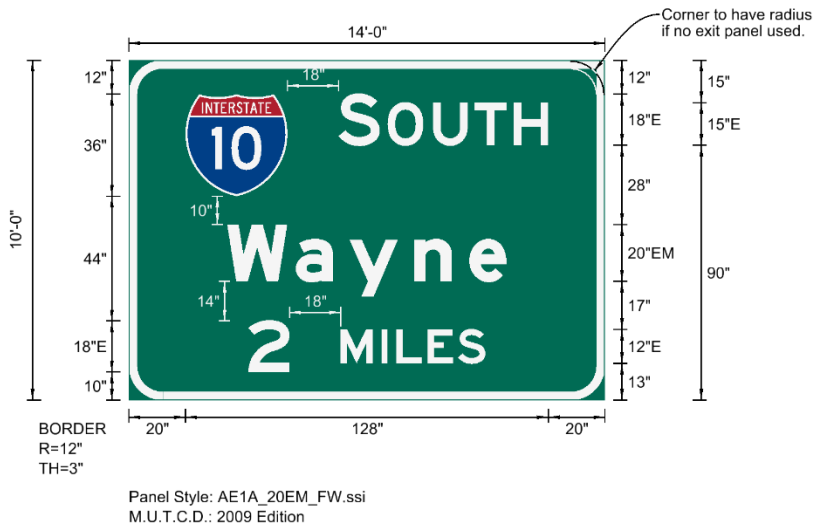

Advance Exit Signs
(AE2-2, AE3-1 & AE3-2)
20" Mixed Case
One Destination

Appendix A – Sign Design Guidelines



For use when exit panel (E1-5) is used.



AE3-2



AE3-1

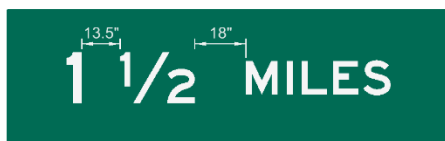

AE3-2

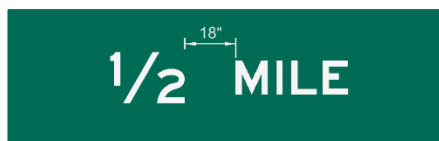

AE2-2

For use when no exit panel is used.

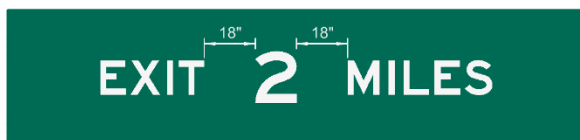

AE3-2

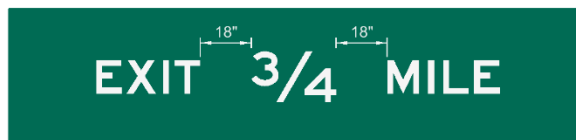

AE3-1

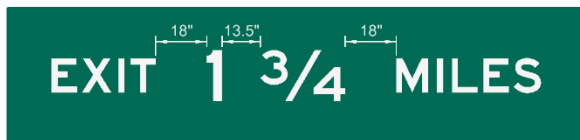

AE3-2

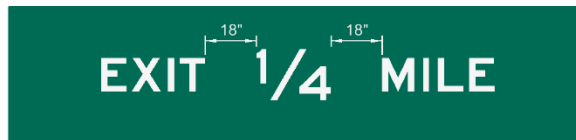

AE2-2

Advance Exit Signs
 Spacing standards for exit
 distances using 18"/12" E

Appendix A – Sign Design Guidelines

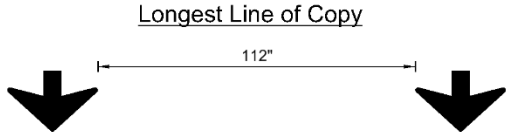

- * 17'-0" Minimum if using two down arrows (AE2-5)
- ** Center single arrow if using one down arrow (AE1-5)
- *** Border location if using one down arrow (AE1-5)

Pull Thru Signs with
Down Arrows (AE1-5 & AE2-5)
16" Mixed Case

Appendix A – Sign Design Guidelines

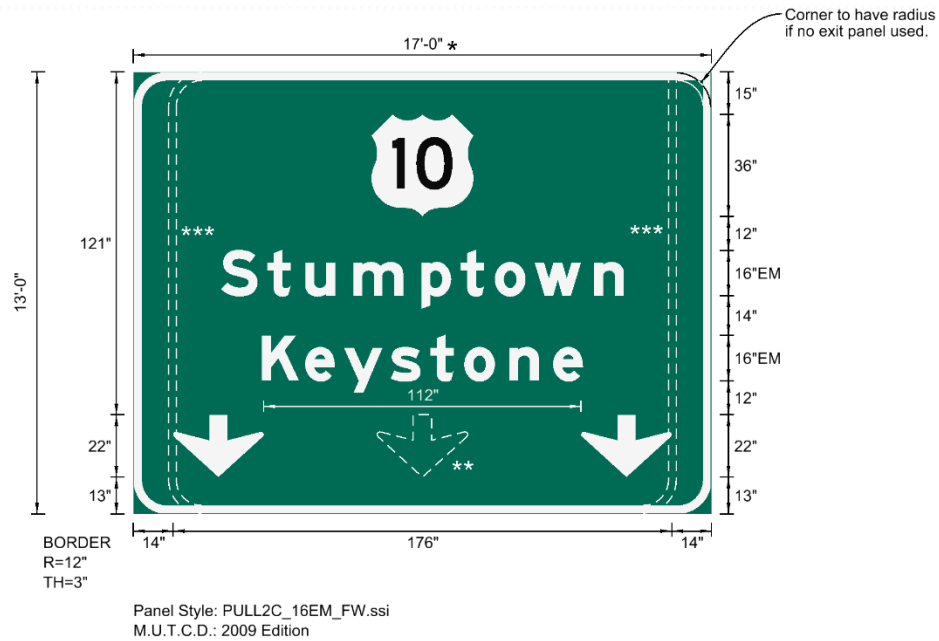

- * 17'-0" Minimum if using two down arrows (AE2-5)
- ** Center single arrow if using one down arrow (AE1-5)
- *** Border location if using one down arrow (AE1-5)

Pull Thru Signs with
Down Arrows (AE1-5 & AE2-5)
16" Mixed Case

Appendix A – Sign Design Guidelines

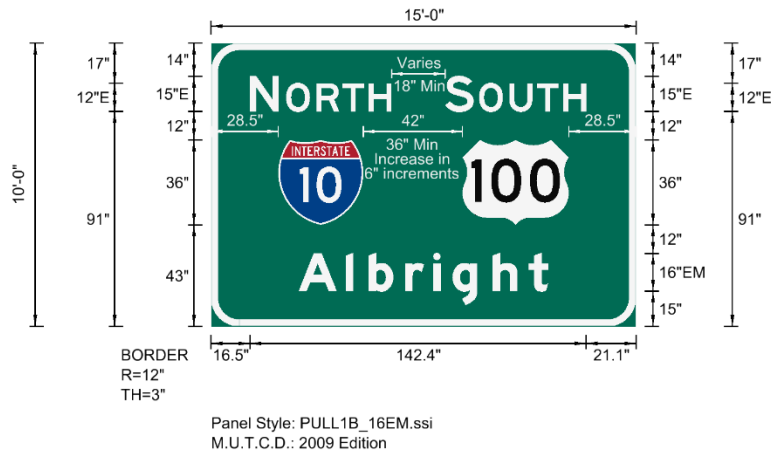
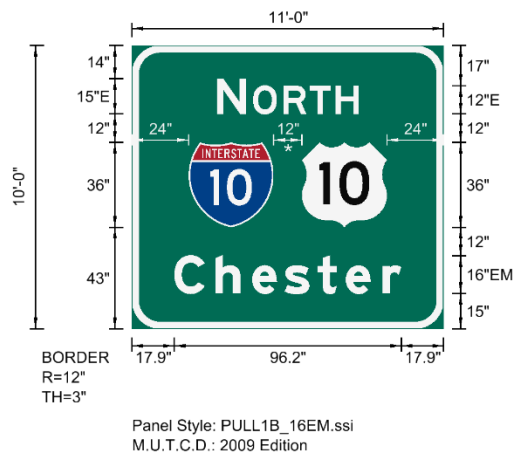

Pull Thru Signs (AE3-4)
16" Mixed Case

* In cases where a single cardinal direction is placed above two shields.

Appendix A – Sign Design Guidelines

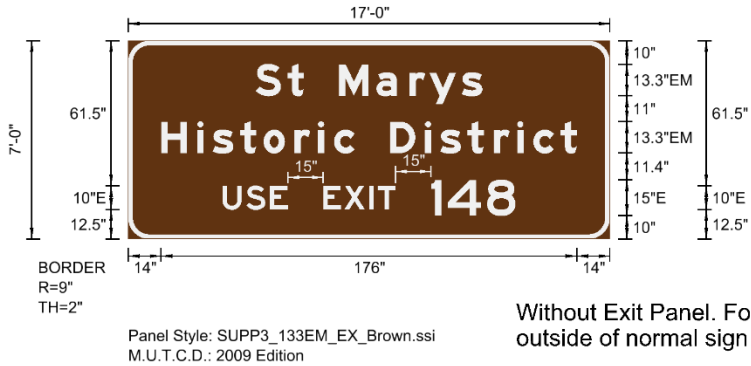
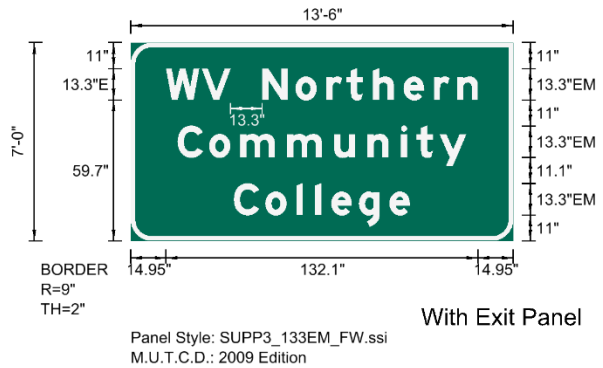
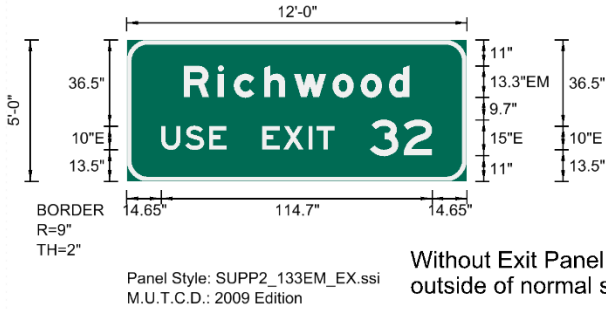

Supplemental Signs (AE5-1)
13.3" Mixed Case
One Destination

Appendix A – Sign Design Guidelines

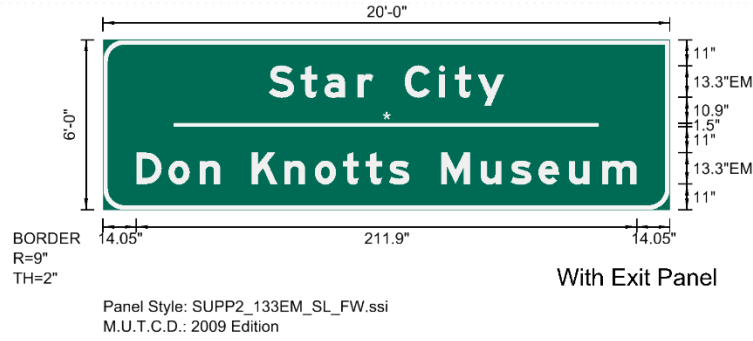

* Length to be approx. 75% of sign width, rounded to the nearest inch, but no longer than length of longest line of text on sign. Thickness to be 75% of border thickness.

Supplemental Signs (AE5-1)
13.3" Mixed Case
Two Destinations

Appendix A – Sign Design Guidelines



For one destination on one line
use spacing as shown on Advance
Intersection Signs.
Panel Style: AD1_106EM



* Length to be approx. 75% of sign width,
rounded to the nearest inch, but no longer
than length of longest line of text on sign.
Thickness to be 75% of border thickness.

Supplemental Signs (AE5-1)
10.6" Mixed Case

Appendix A – Sign Design Guidelines

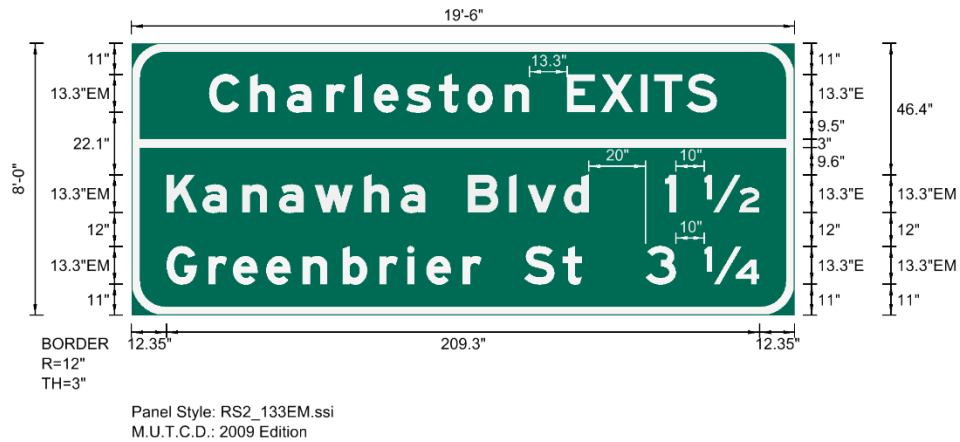

Longest Line of Copy

West Huntington 3 1/2

Sequence Signs (AE6-1)
Freeway Ground Mt. & All Overhead
13.3" Mixed Case

Appendix A – Sign Design Guidelines

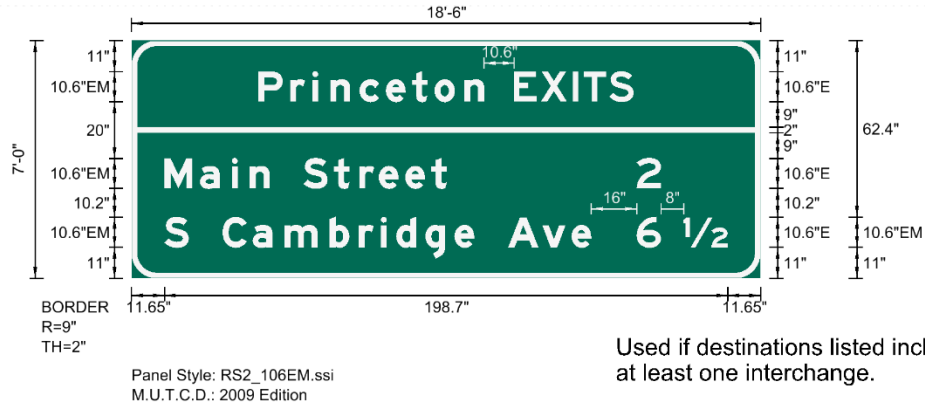

Used if destinations listed include at least one interchange.

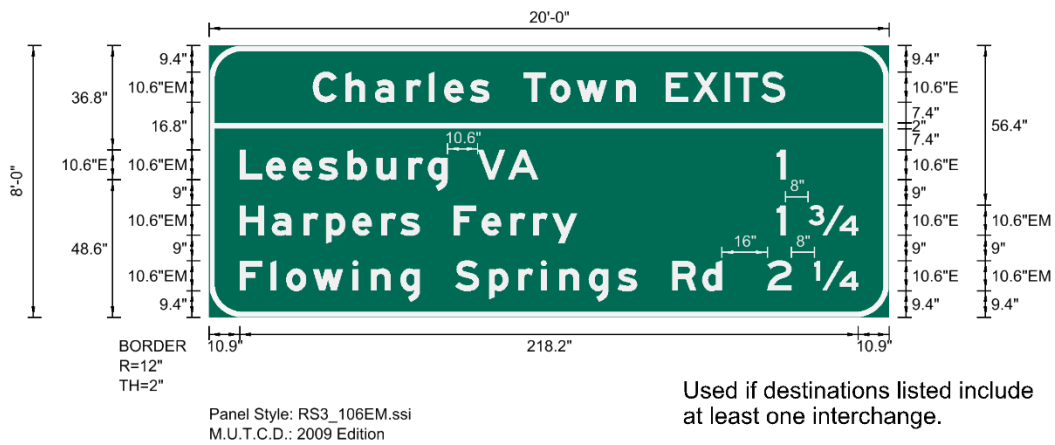

Used if destinations listed include at least one interchange.

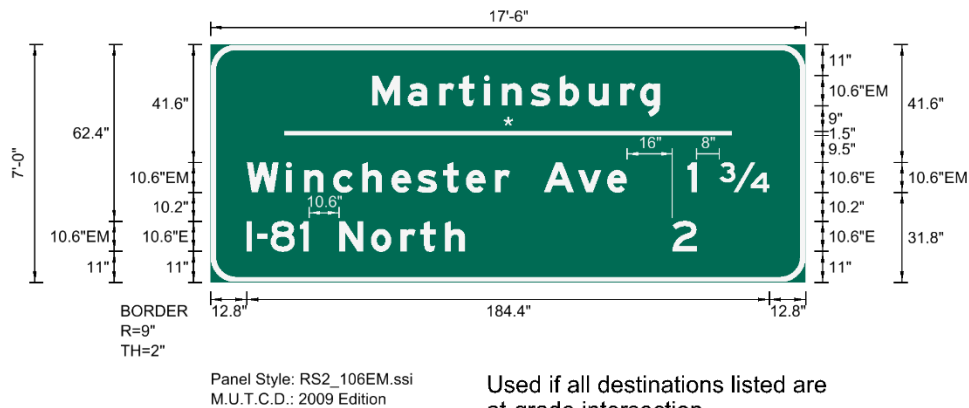

Used if all destinations listed are at-grade intersection.

* Length to be approx. 75% of sign width, rounded to the nearest inch, but no longer than length of longest line of text on sign. Thickness to be 75% of border thickness.

Sequence Signs (AE6-1)
Expressway Ground Mnt. only
10.6" Mixed Case

Appendix A – Sign Design Guidelines

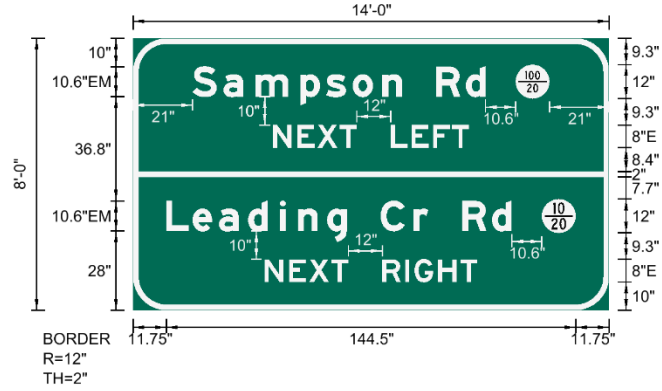

Panel Style: AD2_106EM.ssi
M.U.T.C.D.: 2009 Edition

Longest Line of Copy
Leading Cr Rd 
10.6"



Panel Style: AD1_106EM.ssi
M.U.T.C.D.: 2009 Edition



Panel Style: AD1_106EM.ssi
M.U.T.C.D.: 2009 Edition

Advance Intersection Signs
(AD1-1 & AD1-2)
10.6" Mixed Case

Appendix A – Sign Design Guidelines

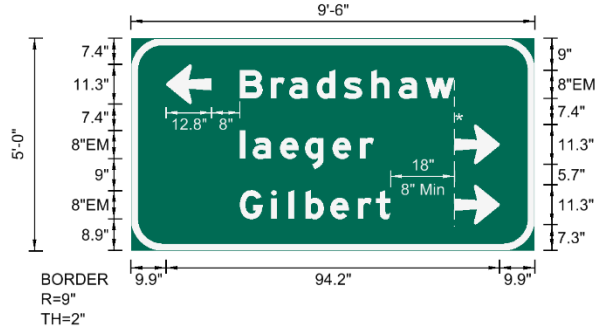

Panel Style: DM3_8EM.ssi
M.U.T.C.D.: 2009 Edition

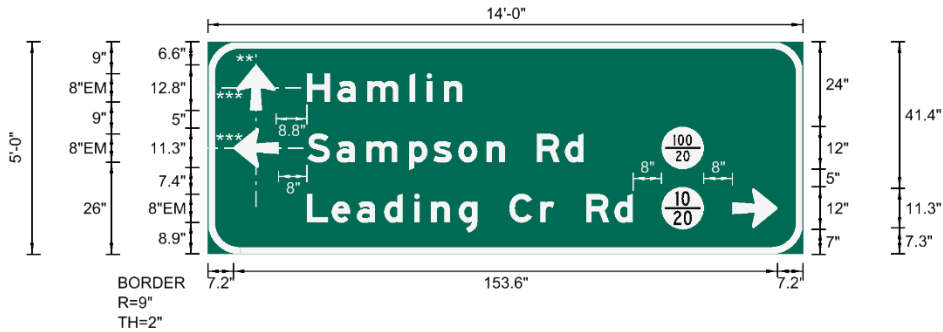

Panel Style: DM3_8EM.ssi
M.U.T.C.D.: 2009 Edition

Longest Line of Copy



Vertical Arrow to Arrow Spacing

11.3"x12.8" arrow with 9" between lines

	← OR →	↖ OR ↗	↑
← OR →	5.7"	6.2"	5.0"
↖ OR ↗	6.2"	6.6"	5.4"
↑	5.0"	5.4"	4.2"

- * Align arrows with end of longest destination if 8" min. can be maintained for all lines.
- ** Center arrows horizontally when stacked.
- *** Center arrows vertically with text.

Directional Signs (D1-3)
8" Mixed Case
Three destinations

Appendix A – Sign Design Guidelines

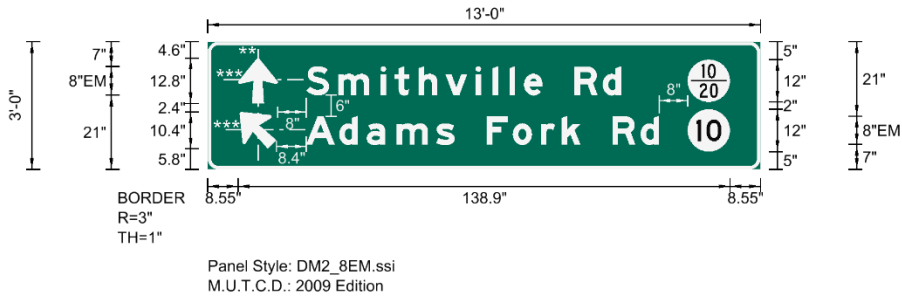
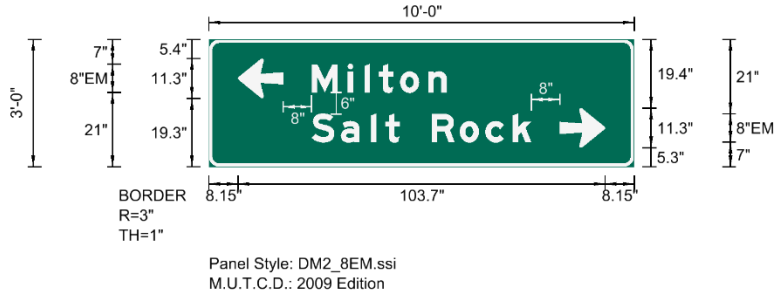

Vertical Arrow to Arrow Spacing

11.3"x12.8" arrow with 6" between lines

	← OR →	↖ OR ↗	↑
← OR →	2.7"	3.2"	2.0"
↖ OR ↗	3.2"	3.6"	2.4"
↑	2.0"	2.4"	1.2"

- * Align arrows with end of longest destination if 8" min. can be maintained for all lines.
- ** Center arrows horizontally when stacked.
- *** Center arrows vertically with text.

Directional Signs (D1-2 & AD2-2)
8" Mixed Case
Two destinations

Appendix A – Sign Design Guidelines

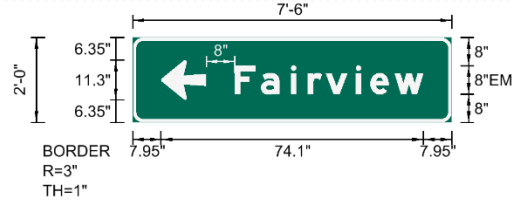

Panel Style: DM1_8EM.ssi
M.U.T.C.D.: 2009 Edition



Panel Style: DM1_8EM.ssi
M.U.T.C.D.: 2009 Edition

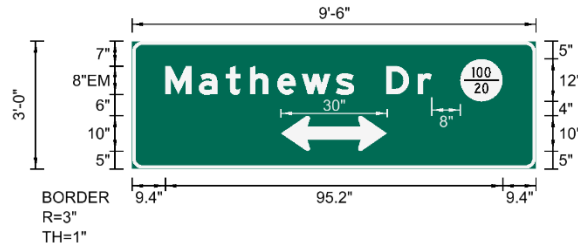

Panel Style: DM1_8EM_DUAL.ssi
M.U.T.C.D.: 2009 Edition



Panel Style: DM2_8EM.ssi
M.U.T.C.D.: 2009 Edition

Alternate layout when width is a concern.

Directional Signs (D1-1 & AD2-1)
8" Mixed Case
One destination

Appendix A – Sign Design Guidelines

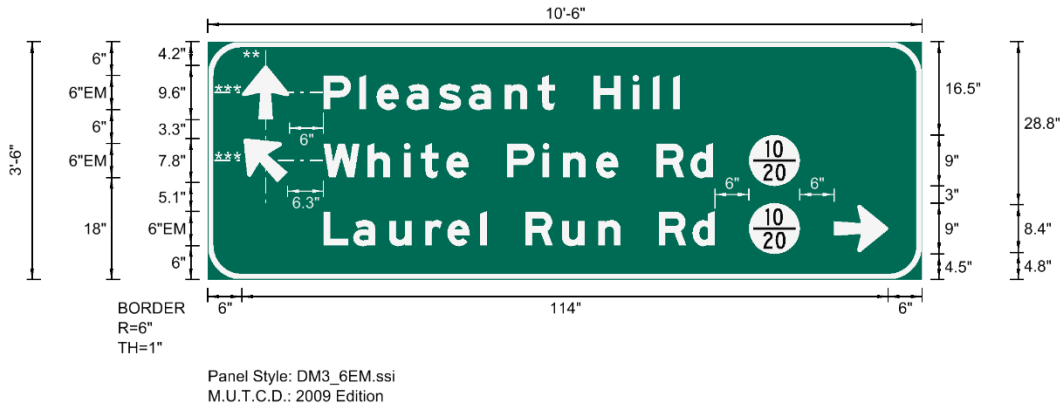
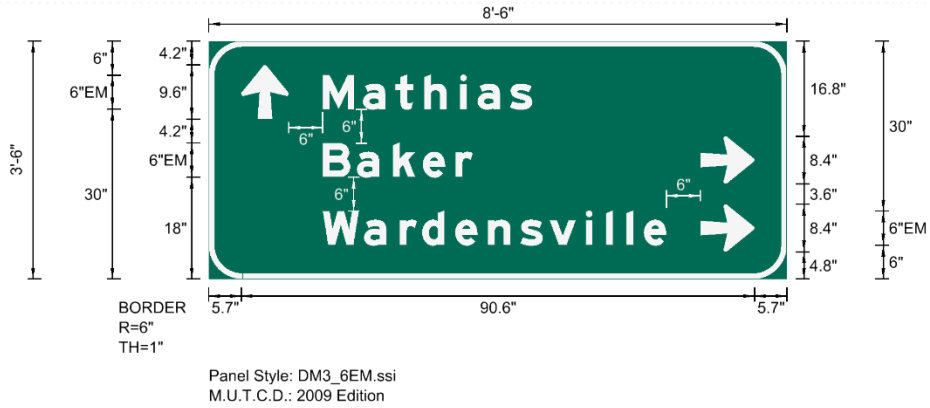

Vertical Arrow to Arrow Spacing

8.4"x9.6" arrow with 6" between lines

	← OR →	↖ OR ↗	↑
← OR →	3.6"	3.9"	3.0"
↖ OR ↗	3.9"	4.2"	3.3"
↑	3.0"	3.3"	2.4"

Conventional
Directional Signs (D1-3)
6" Mixed Case
Three destinations

** Center arrows horizontally when stacked.
*** Center arrows vertically with text.

Appendix A – Sign Design Guidelines

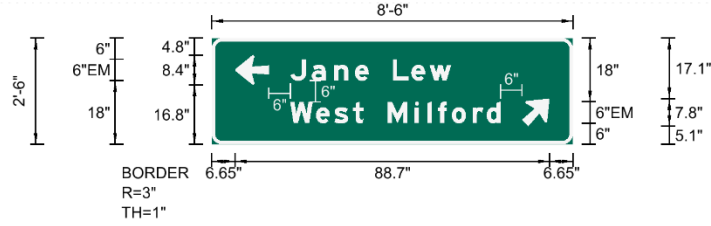

Panel Style: DM2_6EM.ssi
M.U.T.C.D.: 2009 Edition

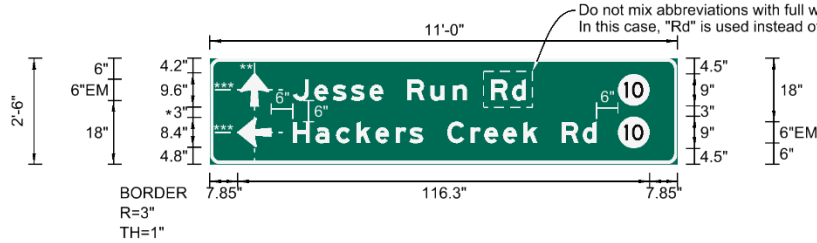

Do not mix abbreviations with full words on same sign. In this case, "Rd" is used instead of "Road".

Panel Style: DM2_6EM.ssi
M.U.T.C.D.: 2009 Edition

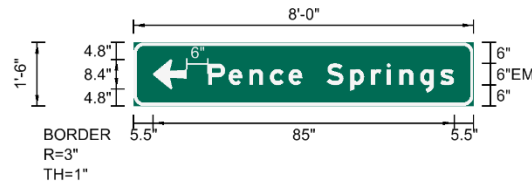

Panel Style: DM1_6EM.ssi
M.U.T.C.D.: 2009 Edition

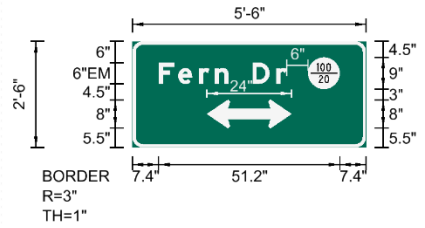

Panel Style: DM1_6EM_DUAL.ssi
M.U.T.C.D.: 2009 Edition

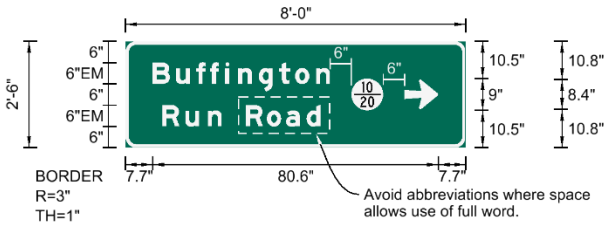

Avoid abbreviations where space allows use of full word.

Panel Style: DM2_6EM.ssi
M.U.T.C.D.: 2009 Edition

- * See arrow to arrow spacing chart on previous page for vertical space for other arrow types.
- ** Center arrows horizontally when stacked.
- *** Center arrows vertically with text.

Directional Signs
(D1-1, D1-2, AD2-1 & AD2-2)
6" Mixed Case
One or Two destinations

Appendix A – Sign Design Guidelines

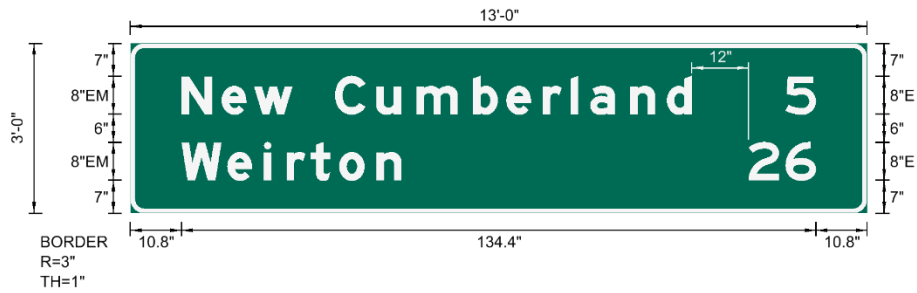
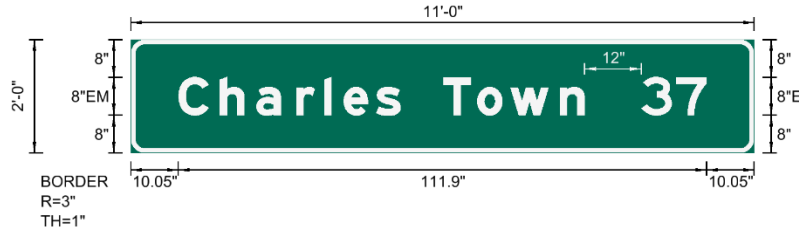

Longest Line of Copy

New Cumberland 26

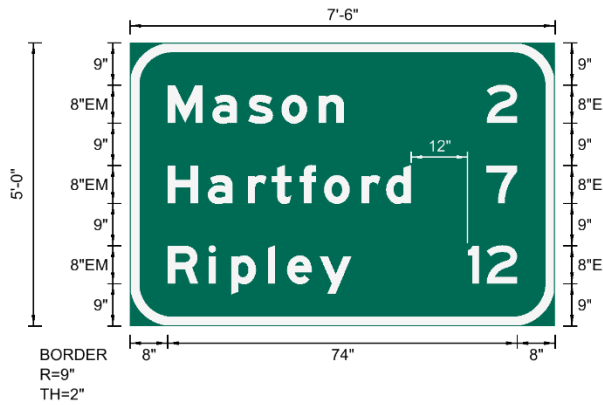

Mileage Signs
(D2-1, D2-2 & D2-3)
8" Mixed Case

Appendix A – Sign Design Guidelines

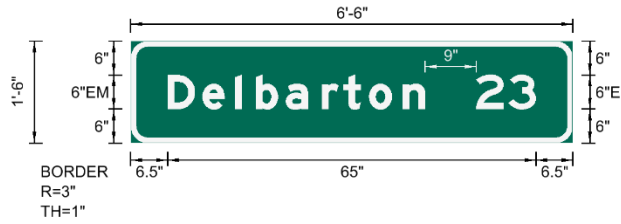

Panel Style: DM1_6EM.ssi
M.U.T.C.D.: 2009 Edition

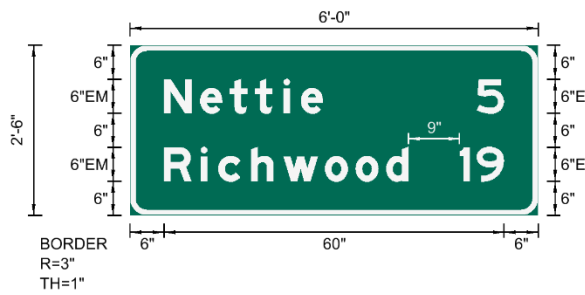

Panel Style: DM2_6EM.ssi
M.U.T.C.D.: 2009 Edition



Panel Style: DM3_6EM.ssi
M.U.T.C.D.: 2009 Edition

Mileage Signs
(D2-1, D2-2 & D2-3)
6" Mixed Case

Appendix A – Sign Design Guidelines

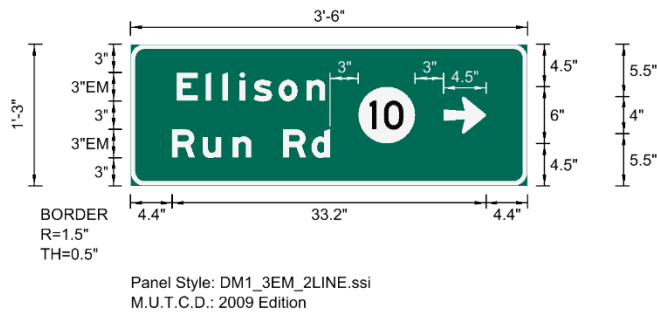
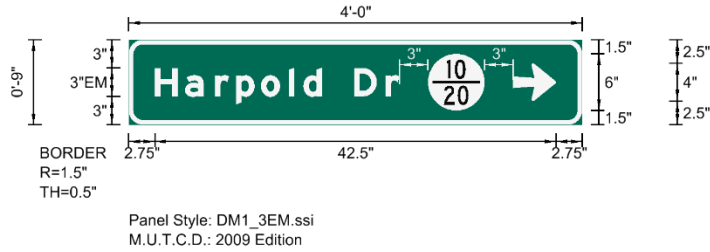
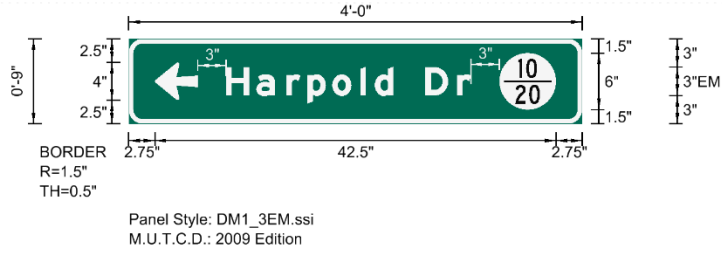

County Road Signs (D16-1)
3" Mixed Case
One destination

Appendix A – Sign Design Guidelines

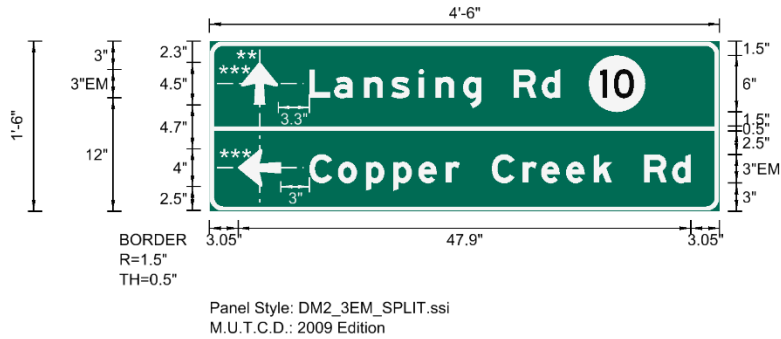
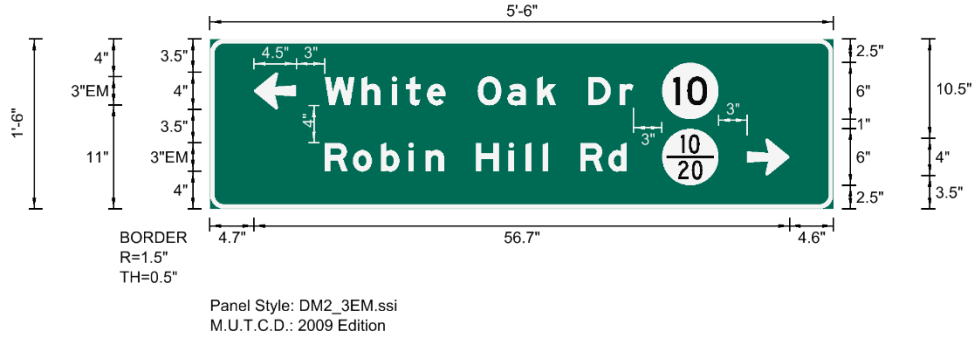

Vertical Arrow to Arrow Spacing

4"x4.5" arrow with 4" between lines

	← OR →	↖ OR ↗	↑
← OR →	3.0"	3.2"	2.8"
↖ OR ↗	3.2"	3.3"	2.9"
↑	2.8"	2.9"	2.5"

- * Align arrow or shield with end of longest destination if 8" min. can be maintained for all lines.
- ** Center arrows horizontally when stacked.
- *** Center arrows vertically with text.

County Road Signs (D16-2)
3" Mixed Case
Two destinations

Appendix A – Sign Design Guidelines

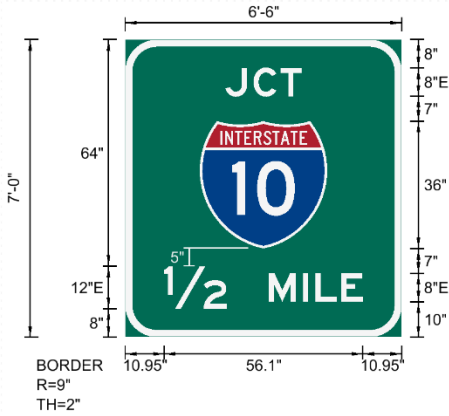

Panel Style: JCT_ACTION MSG.ssi
M.U.T.C.D.: 2009 Edition

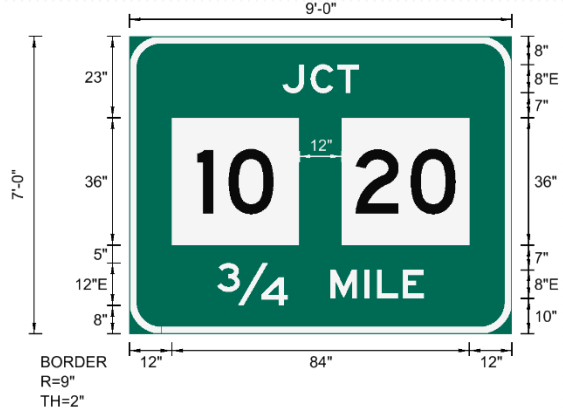

Panel Style: JCT_ACTION MSG.ssi
M.U.T.C.D.: 2009 Edition

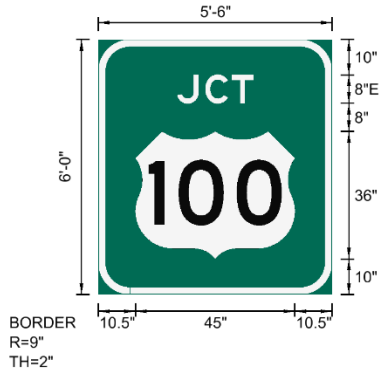

Panel Style: JCT_NO MSG.ssi
M.U.T.C.D.: 2009 Edition

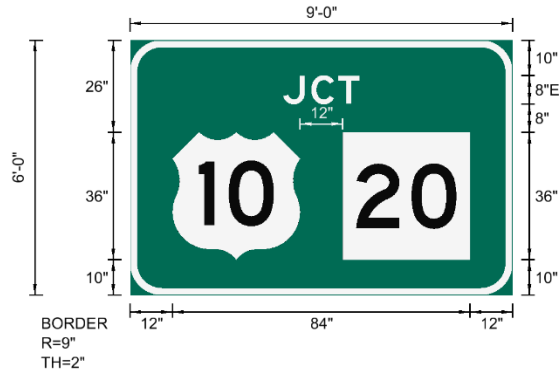

Panel Style: JCT_NO MSG.ssi
M.U.T.C.D.: 2009 Edition

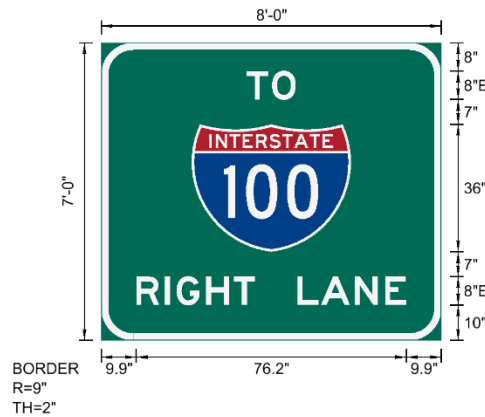

Panel Style: JCT_ACTION MSG.ssi
M.U.T.C.D.: 2009 Edition

Junction Signs (AD5-5) &
Trailblazing Guide Signs (AD5-6)
8" E Message

Appendix A – Sign Design Guidelines

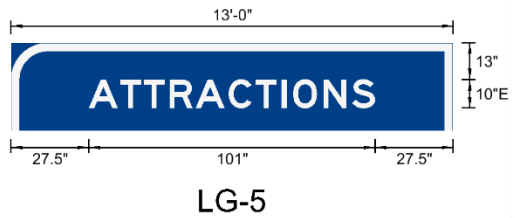
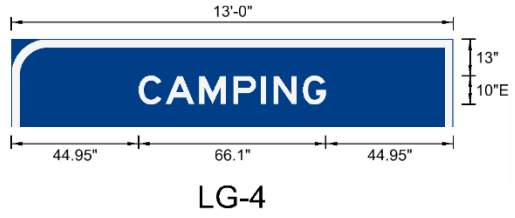
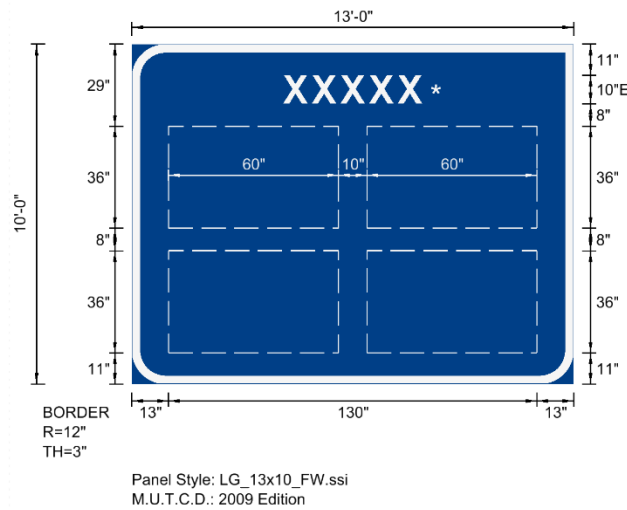
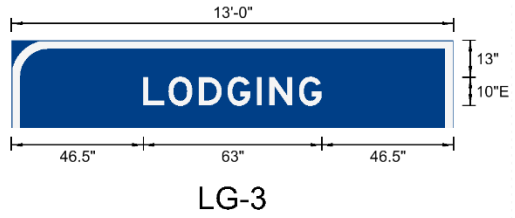
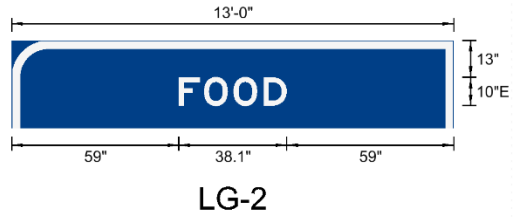
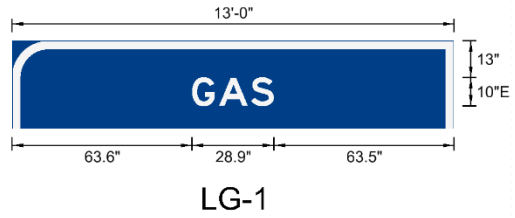
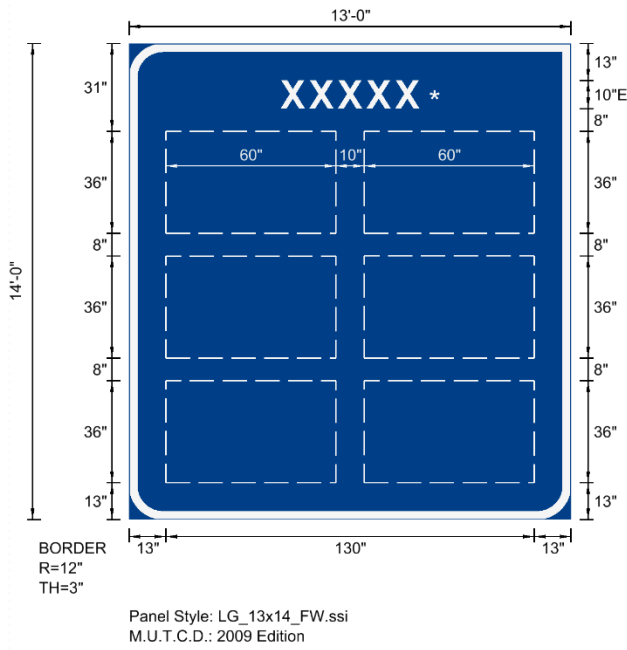

* To be one of the following: GAS, FOOD, LODGING, CAMPING or ATTRACTIONS and spaced as shown on this page.

Logo Signs - Mainline (LG-X)
Freeway - With Exit Panels
10" E Message

Appendix A – Sign Design Guidelines

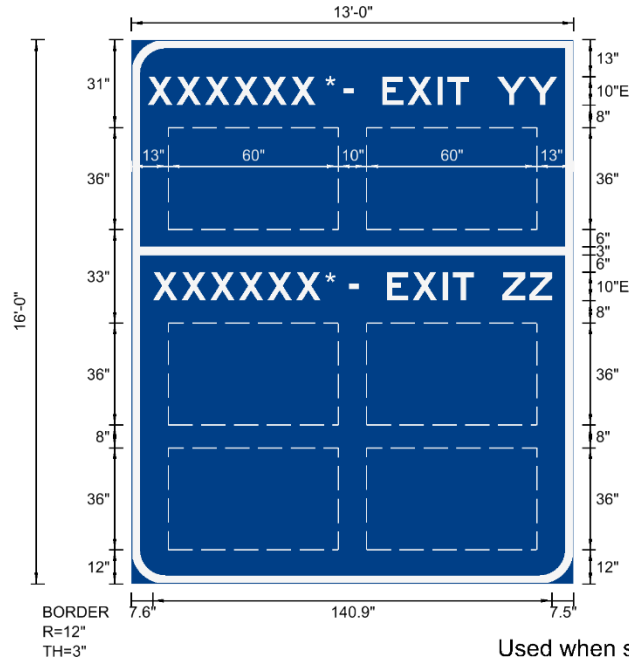

Used when sign includes services available at two different exits.

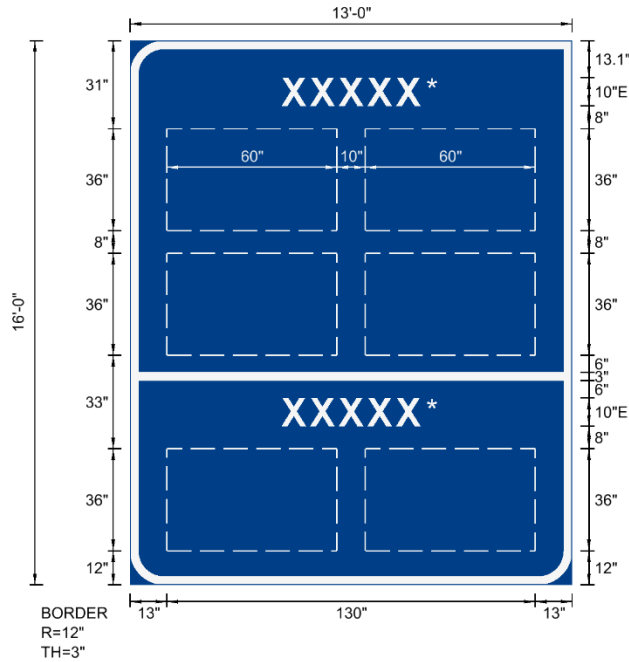

Logo Signs - Mainline (LG-X)
Freeway - With Exit Panels
10" E Message

* To be one of the following: GAS, FOOD, LODGING, CAMPING or ATTRACTIONS and spaced as shown on this page.

Appendix A – Sign Design Guidelines

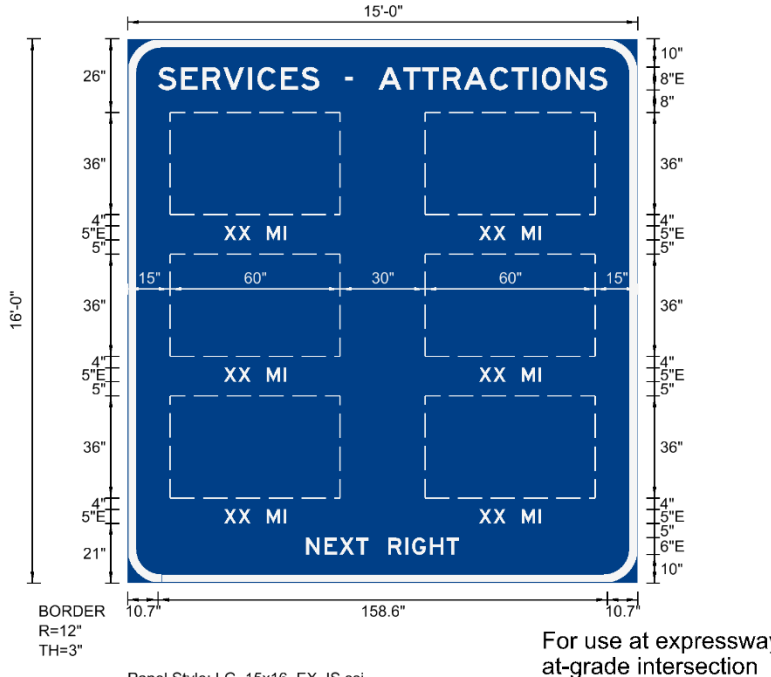
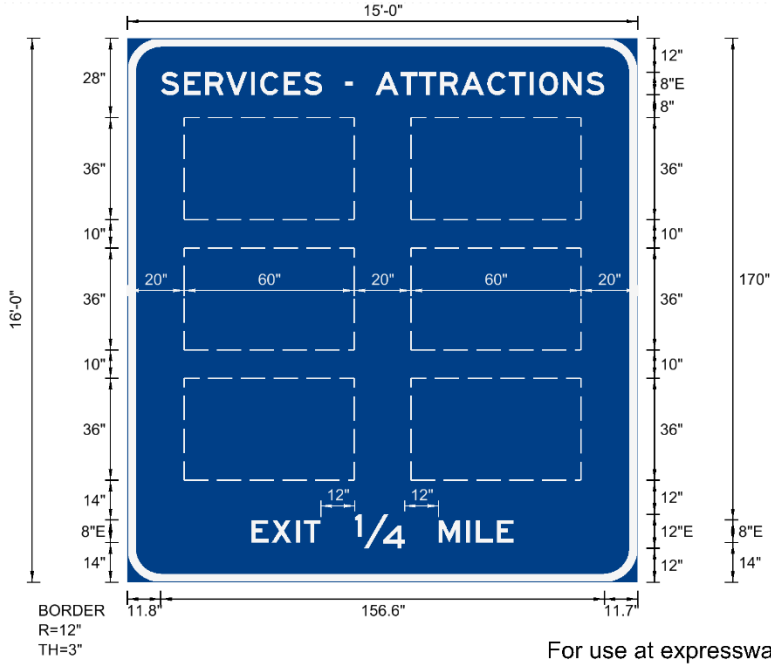

Examples of additional designs and arrangements are available from Traffic Engineering Division.

Logo Signs - Mainline (LG-6)
Expressway - Without Exit Panels
8" E Message

Appendix A – Sign Design Guidelines

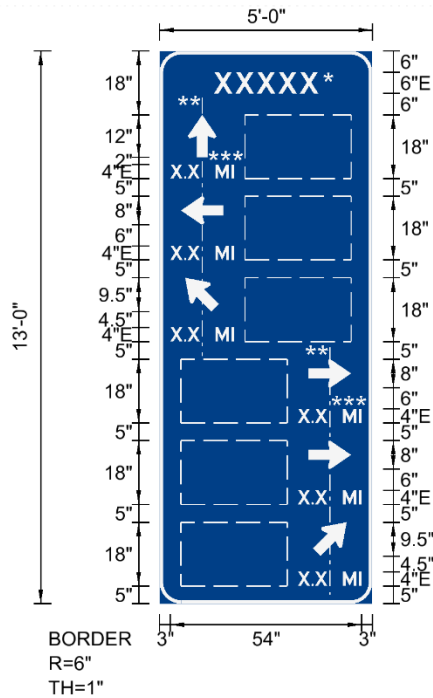

Panel Style: LGR_5x13.ssi
M.U.T.C.D.: 2009 Edition

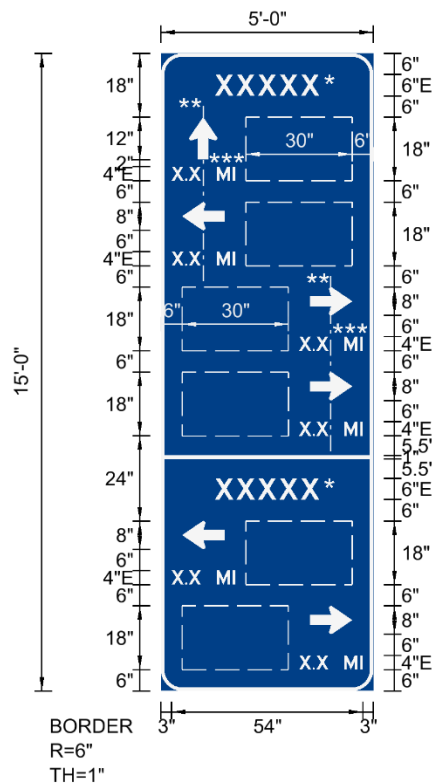

Panel Style: LGR_5x15_SPLIT.ssi
M.U.T.C.D.: 2009 Edition

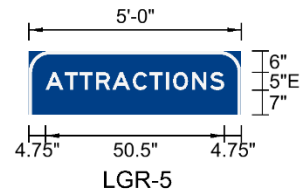
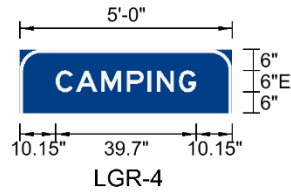
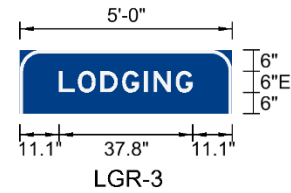
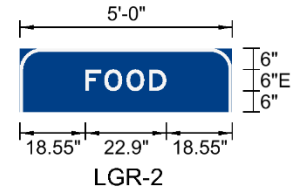
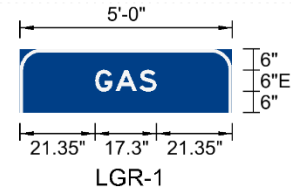

- * To be one of the following: GAS, FOOD, LODGING, CAMPING or ATTRACTIONS and spaced as shown on this sheet.
- ** Center arrows horizontally over distance text. Align top of arrow with top of logo panel.
- *** Center distance text in space between logo panel and border. Align bottom of distance text with bottom of logo panel. Fix distance text length at 18" by spacing letters in GuidSIGN.

Logo Signs - Ramps (LGR-X) 5" E or 6" E Message

WVDOH GuidSIGN Style Library

Advance Exit (AE)					
Sign Type	# of Destinations	A=Shield w/ cardinal beside, B=shield w/ cardinal above, C=no shield	Destination Text height	Destination Font	FW=Square UR corner, EX=radius on all corners
AE	1	A	16	EM	EX
					FW
			20	EM	EX
					FW
		B	16	EM	EX
					FW
			20	EM	EX
					FW
		C	16	EM	EX
					FW
	2	A	16	EM	EX
					FW
			20	EM	EX
					FW
		B	16	EM	EX
					FW
			20	EM	EX
					FW
		C	16	EM	EX
					FW

Example: AE2B_16EM_EX

Advance Intersection (AD)			
Sign Type	# of Destinations	Destination Text height	Destination Font
AD	1	10.6	EM
	2	10.6	EM

Example: AD1_106EM

Directional/Mileage (DM)				
Sign Type	# of Destinations	Destination Text Height	Destination Font	DUAL=Double headed arrow 2LINE=Single road name on 2 lines SPLIT=2 panel version
DM	1	8	EM	
			EM	DUAL
		6	EM	
			EM	DUAL
		3	EM	
			EM	2LINE
	2	8	EM	
		6	EM	
		3	EM	
			EM	SPLIT
	3	8	EM	
		6	EM	

Example: DM2_3EM_SPLIT

Exit Direction (ED)					
Sign Type	# of Destinations	A=Shield w/ cardinal beside, B=shield w/ cardinal above, C=no shield	Destination Text height	Destination Font	FW=Square UR corner, EX=radius on all corners
ED	1	A	16	EM	EX
					FW
			20	EM	EX
					FW
		B	16	EM	EX
					FW
			20	EM	EX
					FW
		C	16	EM	EX
					FW
	2	A	16	EM	EX
					FW
			20	EM	EX
					FW
		B	16	EM	EX
					FW
			20	EM	EX
					FW
		C	16	EM	EX
					FW

Example: ED2B_20EM_FW

Appendix A – Sign Design Guidelines

Exit Only (XO)					
Sign Type	# of Destinations	A=Shield w/ cardinal beside, B=shield w/ cardinal above, C=no shield	Destination Text height	Destination Font	FW=Square UR corner, EX=radius on all corners
XO	1	A	16	EM	EX
					FW
		B	16	EM	EX
					FW
		C	16	EM	EX
					FW
	2	A	16	EM	EX
					FW
		B	16	EM	EX
					FW
		C	16	EM	EX
					FW

Example: XO1C_16EM_EX

Supplemental (SUPP)					
Sign Type	# of Lines of Text	Destination Text height	Destination Font	SL=w/ 75% Line	FW=Square UR corner, EX=radius on all corners
SUPP	2	13.3	EM		EX
					FW
		13.3	EM	SL	FW
	3	10.6	EM		EX
				SL	EX
		13.3	EM		EX
					FW
		13.3	EM	SL	EX
					FW

Example: SUPP2_133EM_SL_FW

Logo signs (LG & LGR)			
Sign Type	Sign size	FW=Square UR corner, EX=radius on all corners	Interchange or Intersection
LG	13x10	FW	
	13x14	FW	
	13x16_SPLIT	FW	
	15x16	EX	IC
		EX	IS
LGR	5x13		
	5x15_SPLIT		

Example: LG_13x16_SPLIT_FW

Pull-through (PULL)					
Sign Type	# of Destinations	A=Shield, B=shield w/ card above, C=Shield w/dn arrow, D=Shield, card above w/ dn arrow	Destination Text height	Destination Font	FW=Square UR corner, EX=radius on all corners
PULL	1	A	16	EM	
		B	16	EM	
		C	16	EM	EX
					FW
		D	16	EM	EX
					FW
	2	C	16	EM	EX
					FW
		D	16	EM	EX
					FW

Example: PULL1D_16EM_EX

Ramp Entrance (RE)			
Sign Type	A=Shield w/ cardinal beside, B=shield w/ cardinal above	Destination Text height	Destination Font
RE	A	8	EM
		16	EM
	B	8	EM
		16	EM

Example: REA_8EM

Rolling Sequence (RS)			
Sign Type	# of Destinations	Destination Text height	Destination Font
RS	2	13.3	EM
		10.6	EM
	3	13.3	EM
		10.6	EM

Example: RS2_133EM

Junction Guide signs (JCT)	
Sign Type	ACTION MSG=Action message below shield, NO MSG=No action message below shield
JCT	ACTION MSG
	NO MSG

Example: JCT_NO MSG

APPENDIX B

Traffic Engineering Directive 220-2

September 1, 2015
TRAFFIC ENGINEERING DIRECTIVE
220-2
Supersedes TED 220-1

SUBJECT: CONTROL AND INTERMEDIATE DESTINATIONS FOR GUIDE SIGNING
ON INTERSTATE, US, AND WV NUMBERED HIGHWAYS

The following cities, towns or locations shall be used as Control and Intermediate Destinations for guide signs on conventional roads, expressways and freeways as indicated. Control destinations are listed in all upper case letters and the associated Intermediate destinations listed between the control cities in lower case letters:

I-64	ASHLAND, KY HUNTINGTON CHARLESTON BECKLEY LEWISBURG LEXINGTON, VA	I-470	COLUMBUS, OH WASHINGTON, PA
I-68	I-79 MORGANTOWN CUMBERLAND, MD	US 11	WINCHESTER, VA Bunker Hill Inwood MARTINSBURG Falling Waters WILLIAMSPORT, MD
I-70	COLUMBUS, OH WHEELING WASHINGTON, PA	US 19	TAZEWELL, VA BLUEFIELD PRINCETON Ghent Shady Springs Beaver BECKLEY Mt. Hope Oak Hill Fayetteville US 60 SUMMERSVILLE Birch River
I-77	WYTHEVILLE, VA BLUEFIELD PRINCETON BECKLEY CHARLESTON PARKERSBURG MARIETTA, OH	I-79	SUTTON Flatwoods Heaters Ireland WESTON Jane Lew West Milford
I-79	CHARLESTON CLARKSBURG FAIRMONT MORGANTOWN WASHINGTON, PA	CLARKSBURG	SHINNSTON
I-81	WINCHESTER, VA MARTINSBURG HAGERSTOWN, MD		

Worthington
 Monongah
 FAIRMONT
 RIVESVILLE
 Westover
 MORGANTOWN
 Mt. Morris, PA
 WAYNESBURG, PA

 US 22 PITTSBURGH, PA
 WEIRTON
 STEUBENVILLE, OH

 US 30 PITTSBURGH, PA
 CHESTER
 EAST LIVERPOOL, OH

 US 33 HARRISONBURG, VA
 FRANKLIN
 Judy Gap
 SENECA ROCKS
 Harman
 Bowden
 ELKINS
 Norton
 BUCKHANNON
 WESTON
 Linn
 GLENVILLE
 Arnoldsburg
 SPENCER
 RIPLEY
 RAVENSWOOD
 COLUMBUS, OH

 US 35 CHILLICOTHE, OH
 POINT PLEASANT

 I-64
 ST ALBANS
 CHARLESTON

 US 40 WASHINGTON, PA
 Valley Grove
 Triadelphia
 WHEELING
 BRIDGEPORT, OH

US 48 WESTON
 BUCKHANNON
 Norton
 ELKINS
 PARSONS
 DAVIS
 Bismarck
 Scherr
 Forman
 MOOREFIELD
 Baker
 WARDENSVILLE
 STRASBURG, VA

 US 50 ATHENS, OH
 Belpre, OH
 PARKERSBURG
 Ellenboro
 Pennsboro
 West Union
 Salem
 CLARKSBURG
 BRIDGEPORT
 (eastbound only)
 GRAFTON
 Red House, MD
 Gormanian
 Mt. Storm
 KEYSER
 Junction
 Burlington
 ROMNEY
 Augusta
 Capon Bridge
 WINCHESTER, VA

 US 52 BLAND, VA
 BLUEFIELD
 Bramwell
 Northfork
 Keystone
 Kimball
 WELCH
 Iaeger
 Gilbert
 Delbarton

WILLIAMSON
 Kermit
 Fort Gay
 Kenova
 HUNTINGTON
 CHESAPEAKE, OH

 US 60 COVINGTON, VA
 WHITE SULPHUR PRINGS
 Caldwell
 LEWISBURG
 Alta
 Sam Black Church
 Rupert
 RAINELLE
 US 19
 Ansted
 GAULEY BRIDGE
 Smithers
 MONTGOMERY
 Cedar Grove
 Belle
 CHARLESTON
 SOUTH CHARLESTON
 ST ALBANS
 HURRICANE
 MILTON
 BARBOURSVILLE
 HUNTINGTON
 CEREDO
 KENOVA
 ASHLAND, KY

 US 119 PIKEVILLE, KY
 WILLIAMSON
 LOGAN
 Chapmanville
 Madison
 South Charleston
 CHARLESTON
 Elkview
 CLENDENIN
 SPENCER
 Arnoldsburg
 GLENVILLE
 WESTON
 BUCKHANNON

PHILIPPI
 GRAFTON
 MORGANTOWN
 UNIONTOWN, PA

 US 219 RICH CREEK, VA
 PETERSTOWN
 Union
 Ronceverte
 LEWISBURG
 Renick
 Hillsboro
 Mill Point
 MARLINTON
 Slatyfork
 Valley Head
 Huttonsville
 Mill Creek
 Beverly
 ELKINS
 PARSONS
 THOMAS
 Silver Lake, MD
 OAKLAND, MD

 US 220 MONTEREY, VA
 FRANKLIN
 PETERSBURG
 MOOREFIELD
 US 48
 US 50
 KEYSER
 CUMBERLAND, MD

 US 250 MONTEREY, VA
 Thornwood
 Barton
 Durbin
 Huttonsville
 Mill Creek
 Beverly
 ELKINS
 Norton
 Junior
 Belington
 PHILLIPPI

Pruntytown
 FAIRMONT
 Farmington
 MANNINGTON
 Hundred
 Littleton
 CAMERON
 MOUNDSVILLE
 WHEELING
 BRIDGEPORT, OH

 US 340 WINCHESTER, VA
 Berryville, VA
 CHARLES TOWN
 Bolivar
 HARPERS FERRY
 FREDERICK, MD

 US 460 PEARISBURG, VA
 Oakvale
 PRINCETON
 BLUEFIELD
 TAZEWELL, VA

 US 522 HANCOCK, MD
 BERKELEY SPRINGS
 WINCHESTER, VA

 WV 1

 WV 2 HUNTINGTON
 POINT PLEASANT
 Mt. Alto
 RAVENSWOOD
 PARKERSBURG
 Belmont
 St. Marys
 Friendly
 Sistersville
 Paden City
 New Martinsville
 MOUNDSVILLE
 (southbound only)
 Moundsville
 (northbound only)
 McMechen
 Benwood

WHEELING
 Wellsburg
 Follansbee
 WEIRTON
 New Cumberland
 Newell
 CHESTER

 WV 3 WEST HAMLIN
 HAMLIN
 Yawkey
 DANVILLE
 RACINE
 Seth
 WHITESVILLE
 Glen Daniel
 BECKLEY
 Shady Springs
 HINTON
 ALDERSON
 UNION
 SWEET SPRINGS

 WV 4 CLENDENIN
 Clay
 Ivydale
 Gassaway
 SUTTON
 Flatwoods
 ROCK CAVE

 WV 5 ELIZABETH
 GRANTSVILLE
 GLENVILLE
 BURNSVILLE

 WV 6 US 60
 MONTGOMERY

 WV 7 NEW MARTINSVILLE
 Hundred
 Wadestown
 Blacksville
 MORGANTOWN
 Masontown
 Reedsville
 KINGWOOD

Terra Alta
 OAKLAND, MD
 WV 8 WEIRTON
 NEW MANCHESTER
 WV 9 PAW PAW
 BERKELEY SPRINGS
 Hedgesville
 MARTINSBURG
 Kearneysville
 Ranson
 CHARLES TOWN
 LEESBURG, VA
 WV 10 PRINCETON
 Matoaka
 MULLENS
 PINEVILLE
 Oceana
 MAN
 LOGAN
 West Logan
 Mitchell Heights
 CHAPMANVILLE
 West Hamlin
 HUNTINGTON
 WV 11
 WV 12 PETERSTOWN
 Forest Hills
 HINTON
 ALDERSON
 ALTA
 WV 13
 WV 14 SPENCER
 Reedy
 ELIZABETH
 Mineral Wells
 PARKERSBURG
 VIENNA

WILLIAMSON
 WV 14 ALT WV 14
 WV 95
 WV 618
 WV 15 SUTTON
 WEBSTER SPRINGS
 VALLEY HEAD
 WV 16 TAZEWELL, VA
 WAR
 WELCH
 PINEVILLE
 MULLENS
 Rhodell
 Sophia
 BECKLEY
 MT HOPE
 OAK HILL
 FAYETTEVILLE
 GAULEY BRIDGE
 Belva
 CLAY
 Ivydale
 Arnoldsburg
 GRANTSVILLE
 Smithville
 HARRISVILLE
 ELLENBORO
 ST. MARYS
 WV 17 LOGAN
 Ramage
 MADISON
 WV 18 SISTERSVILLE
 MIDDLEBOURNE
 WEST UNION
 LINN
 WV 19
 WV 20 BLUEWELL
 PRINCETON
 ATHENS
 HINTON

Meadow Bridge
 RAINELLE
 Charmco
 Quinwood
 Nettie
 Fenwick
 RICHWOOD
 Craigsville
 Camden-on-Gauley
 Cowen
 WEBSTER SPRINGS
 Diana
 Rock Cave
 BUCKHANNON
 Hodgesville
 Stonewood
 Nutter Fort
 CLARKSBURG
 Lumberport
 Smithfield
 Pine Grove
 NEW MARTINSVILLE

WV 21

WV 22

WV 23 ALMA
 SALEM

WV 24 AURORA
 THOMAS

WV 25 CHARLESTON
 DUNBAR
 INSTITUTE
 NITRO

WV 26 FELLOWSVILLE
 Tunnelton
 KINGWOOD
 Albright
 BRUCETON MILLS
 US 40

WV 27 WV 88
 WELLSBURG

WV 27
 ALT. FOLLANSBEE
 BURGETTSTOWN, PA

WV 28 MARLINTON
 Huntersville
 Dunmore
 GREEN BANK
 Bartow
 Thornwood
 Circleville
 Judy Gap
 SENECA ROCKS
 PETERSBURG
 MOOREFIELD
 US 48
 Junction
 ROMNEY
 Springfield
 Fort Ashby
 Ridgeley

CUMBERLAND MD.

WV 29 BAKER
 Rio
 AUGUSTA
 Slanesville
 PAW PAW

WV 31 WILLIAMSTON
 WV 2
 DEERWALK
 US 50
 CAIRO
 HARRISVILLE
 WV 32 HARMAN
 DAVIS
 THOMAS

WV 33

WV 34 HAMLIN
 HURRICANE
 WINFIELD

	Red House KENNA	WV 43	MON-FAYETTE EXPRESSWAY MORGANTOWN I-68 UNIONTOWN, PA
WV 36	SPENCER Wallback CLAY	WV 44	HOLDEN LOGAN Switzer GILBERT
WV 37	LOUISA, KY FT. GAY WAYNE EAST LYNN RANGER	WV 45	MARTINSBURG SHEPHERDSTOWN
WV 38	PHILLIPI Nestorville PARSONS	WV 46	PIEDMONT KEYSER FT. ASHBY
WV 39	GAULEY BRIDGE Belva Drennen SUMMERSVILLE Nettie Fenwick RICHWOOD Mill Point Marlinton Huntersville MINNEHAHA SPRINGS WARM SPRINGS, VA	WV 47	PARKERSBURG US 50 SMITHVILLE Burnt House Linn WESTON
WV 41	BECKLEY Piney View PRINCE CLIFFTOP LOOKOUT Nallen MT. NEBO SUMMERSVILLE WV 150 CRAIGSVILLE	WV 48	
		WV 49	WILLIAMSON MATEWAN EDGARTON
WV 42	PETERBURG Scherr US 48 MT. STORM ELK GARDEN KITZMILLER, MD	WV 51	INWOOD Middleway CHARLES TOWN
		WV 53	ELIZABETH WV 47
		WV 54	MULLENS Maben Lester Sophia BECKLEY
		WV 55	MOOREFIELD BAKER WARDENSVILLE

	STRASBURG, VA	WV 63	CALDWELL ORGAN CAVE RONCEVERTE ALDERSON
WV 56	RAVENSWOOD Silverton SANDYVILLE REEDY	WV 65	DELBARTON US 119 NAUGATUCK
WV 57	PHILIPPI CLARKSBURG	WV 66	CASS SNOWSHOE
WV 58	STONEWOOD Anmoore BRIDGEPORT	WV 67	WELLSBURG BETHANY
WV 59	LOST CITY WOODSTOCK, VA	WV 68	RAVENSWOOD Washington US 50 PARKERSBURG
WV 60		WV 69	HUNDRED WAYNESBURG, PA
WV 61	PRINCE MT.HOPE OAK HILL Deep Water MONTGOMERY Pratt East Bank Chesapeake MARMET CHARLESTON	WV 71	MATOAKA Montcalm BLUEWELL
WV 62	RIPLEY Cottageville NEW HAVEN Hartford MASON PT. PLEASANT Leon BUFFALO ELEANOR Red House POCA CROSS LANES DUNBAR	WV 72	HARMAN Red Creek Hendricks PARSONS Etam Macomber ROWLESBURG KINGWOOD
		WV 73	Logan Connector US 119 WV 44 LOGAN
		WV 74	COXS MILL Auburn Pullman PENNSBORO

	JOSEPHS MILLS		BETHANY
WV 75	KENOVA LAVALETTE	WV 89	WV 27 PROCTOR US 250
WV 76	PHILIPPI FLEMINGTON BRIDGEPORT	WV 90	THOMAS Bayard GORMANIA
WV 78		WV 91	
WV 79		WV 92	WHITE SULPHUR SPRINGS Minnehaha Springs Frost GREEN BANK Bartow Durbin Huttonsville Mill Creek Beverly
WV 80	BRADSHAW IAEGER GILBERT MAN		ELKINS Norton Junior
WV 82	BIRCH RIVER COWEN		BELINGTON Nestorville Newburg
WV 83	GRUNDY, VA BRADSHAW WAR		REEDSVILLE MORGANTOWN
WV 84	FROST VANDERPOOL, VA	WV 93	US 48 DAVIS MT. STORM (northbound only)
WV 85	MADISON VAN (southbound only) WHARTON WV 99 Kopperston OCEANA		SCHERR (southbound only) KEYSER
WV 86	GLEN DALE BETHLEHEM	WV 94	RACINE MARMET
WV 87	EVANS	WV 95	Camden Ave US 50 PARKERSBURG I-77
WV 88	US 250 GLEN DALE (southbound only) BETHLEHEM WHEELING WEST LIBERTY		

WV 96		WV 112	BLUEFIELD INGLESIDE OAKVALE
WV 97	BECKLEY Maben PINEVILLE Baileysville GILBERT	WV 114	CHARLESTON YEAGER AIRPORT BIG CHIMNEY I-79
WV 98	NUTTER FORT US 19 US 50	WV 115	WV 51 WV 9(This route is Located on Old Rt. 9 Through Charles Town.)
WV 99	BECKLEY Glen Daniel WV 85	WV 120	BRAMWELL POCAHONTAS, VA
WV 100	WESTOVER GRANVILLE MAIDSVILLE US 19	WV 121	COALFIELDS EXPRESSWAY GRUNDY, VA Bradshaw War
WV 101			WELCH PINEVILLE MULLENS WV 16
WV 102	VIRGINIA ROUTE 102		
WV 103	WELCH GARY ANAWALT	WV 122	FOREST HILL Greenville ROCK CAMP
WV 104	US 460 WV 20 (Stafford Drive and Hospital Road in Princeton)	WV 123	MERCER COUNTY AIRPORT FALLS MILLS, VA
WV 105	WV 2 US 22 (This route is known as Pennsylvania Ave., Colliers Way in Weirton)	WV 124	INSTITUTE CONNECTOR (WV 25 - WV 622)
WV 106	HUNTINGTON CHESAPEAKE, OH	WV 125	(This route will be the New River Parkway.)
WV 107	WV 20 WV 3 (This route is known as Hinton Connector.)	WV 127	US 522 PAW PAW
		WV 129	DRENNEN SUMMERSVILLE DAM MT. NEBO

WV 131	(This route is known as Saltwell Rd.) SHINNSTON I-79 BRIDGEPORT	WV 210	(This route is located in Beckley.)
WV 140	(This route is known As the Parkersburg Toll Bridge.)	WV 211	(This route is located in Mt. Hope.)
WV 150	SLATYFORK RICHWOOD US 19 NORTH	WV 214	ALUM CREEK YAWKEY
WV 152	HUNTINGTON WAYNE ECHO CRUM	WV 218	WORTHINGTON FARMINGTON FAIRVIEW BLACKSVILLE WAYNESBURG, PA
WV 154	Shawnee Parkway ASHLAND, KY CRUMPLER I-77 (GHENT)	WV 230	SHEPHERDSTOWN HARPERS FERRY
WV 161	BISHOP ANAWALT US 52	WV 251	(This route is known As the Suspension Bridge in Wheeling.)
WV 180	NEW MARTINSVILLE MIDDLEBOURNE	WV 252	(This route is knows as the Aetnaville Bridge, Wheeling.)
WV 193	Connector from US 60 To WV 2 US 60 WV 2	WV 259	BROADWAY, VA MATHIAS BAKER WARDENSVILLE GORE, VA
WV 201		WV 260	Old WV 2 Huntington to Merrick Creek Rd (new WV 2)
WV 203	WASHINGTON	WV 270	WEST MILFORD LOST CREEK
WV 204	DANESE MEADOW BRIDGE	WV 273	Gateway Connector I-79 FAIRMONT
WV 208	WV ROUTE 2 WV ROUTE 8	WV 279	BRIDGEPORT I-79 AT WV 707

	US 50	WV 473	GLENVILLE Tanner BURNT HOUSE
WV 290			
WV 301	SALT ROCK WV 303 MILTON	WV 480	SHARPSBURG, MD SHEPHERDSTOWN KEARNEYSVILLE
WV 303	HAMLIN WV 301	WV 501	CHARLESTON WV 622
WV 305	SURVEYOR LESTER	LSR 507	(This route is known As Cove Road in Weirton.)
WV 307	BEAVER SHADY SPRINGS I-64	WV 527	I-64 HUNTINGTON CHESAPEAKE, OHIO
WV 310	GRAFTON FAIRMONT	WV 598	BLUEFIELD ROCKY GAP, VA (This route is known As Old Rt. 21 across East River Mtn in Mercer Co.)
WV 311	WHITE SULPHUR SPRINGS CROW, VA		
WV 331	COTTAGEVILLE MT. ALTO	WV 601	JEFFERSON ROAD MACCORKLE AVE US 119
WV 338		WV 612	OAK HILL MOSSY
WV 372	EAST LYNN BRANCLAND (northbound only) WEST HAMLIN (southbound only)	WV 618	BELPRE, OH PARKERSBURG US 50
WV 401	WEST LIBERTY US 40 VALLEY GROVE I-70 DALLAS PIKE	WV 622	INSTITUTE CROSS LANES SISSONVILLE
WV 471	CAIRO CISCO	WV 635	JOLO RICHLAND, VA
		WV 701	PINE GROVE WILEYVILLE

WV 703 WADESTOWN (None of these
 were ever signed.)
 FAIRVIEW
 Grant Town
 RIVESVILLE

WV 705 US 19
 US 119
 I-68
 (This route is known
 As the West Morgantown
 Bypass.)

WV 707 (This route is known
 as FBI Center Rd.)

WV 807 (This route is known
 as the St. Mary's
 Bridge.)

LSR 857 (This route is known
 as the East Morgantown
 Bypass.)

US 119
 WV 7
 US 119
 I-68
 UNIONTOWN, PA

WV 869 Toyota Bridge
 US 35
 BUFFALO

WV 870 KERMIT BRIDGE
 KY 40 TO US 52

WV 891 CAMERON
 WAYNESBURG, PA

WV 892 (This route is located
 near Washington in
 Wood County)

WV 68

Washington
 US 50

WV 901 HEDGESVILLE
 SPRING MILLS

WV 922 US 119
 REEDSVILLE

WV 956 ROCKET CENTER

WV 971 BAILEYSVILLE
 Clear Fork
 OCEANA

WV 972 (This route is known
 As Old US 220 at New
 Creek in Mineral CO.)
 GRAFTON
 (southbound only)
 US 50
 KEYSER
 (northbound only)

Cindy Cramer, Director
 Traffic Engineering Division