



State of West Virginia
Request For Quotation

Procurement Folder : 118304

Document Description : WORK AREA PROTECT IMPACT ATTENUATOR PARTS

Procurement Type : Agency Master Agreement

Date Issued	Solicitation Closes	Solicitation No	Version	Phase
2015-10-22	2015-11-04 13:30:00	ARFQ 0803 DOT1600000007	1	Final

SUBMIT RESPONSES TO:	VENDOR
FINANCE & ADMINISTRATION DIVISION OF HIGHWAYS BLDG 5, RM A-220 1900 KANAWHA BLVD E CHARLESTON US	Vendor Name, Address and Telephone <i>Protection Services Inc.</i> <i>1011 Mumma Rd, suite 101</i> <i>Lemoyne, Pa. 17043</i> <i>717-236-4307</i>
WV 25302	

FOR INFORMATION CONTACT THE

Dusty J Smith
(304) 558-9398
dusty.j.smith@wv.gov

Signature X *[Signature]* FEIN # *23-2001976* DATE *11/2/15*

INVOICE TO		SHIP TO	
ALL STATE AGENCIES VARIOUS LOCATIONS AS INDICATED BY ORDER		STATE OF WEST VIRGINIA VARIOUS LOCATIONS AS INDICATED BY ORDER	
No City	WV99999	No City	WV 99999
US		US	

Line	Commodity Line Description	Qty	Unit Issue	Unit Price	Total Price
1	SHEAR BOLTS	1.00000	EA	1.08	1.08

Commodity Code	Manufacturer	Model #	Specification
32101515	Work Area Protection		As specified by manufacturer

Extended Description
 WORK AREA PROTECTION/SCI PRODUCTS SMART CUSHION ATTENUATORS
 SHEAR BOLT

INVOICE TO		SHIP TO	
ALL STATE AGENCIES VARIOUS LOCATIONS AS INDICATED BY ORDER		STATE OF WEST VIRGINIA VARIOUS LOCATIONS AS INDICATED BY ORDER	
No City	WV99999	No City	WV 99999
US		US	

Line	Commodity Line Description	Qty	Unit Issue	Unit Price	Total Price
2	SIDE (FENDER) PANELS	1.00000	EA	405.-	405.-

Commodity Code	Manufacturer	Model #	Specification
32101515	Work Area Protection		As specified by manufacturer + bid

Extended Description
 WORK AREA PROTECTION/SCI PRODUCTS SMART CUSHION ATTENUATORS
 SIDE (FENDER) PANELS
 FRONT SLED SIDE PANEL (INCLUDE KEEPERS AND ANY OTHER REQUIRED HARDWARE FOR ATTACHMENT)
 PART DETAIL SHEET 63/64

INVOICE TO		SHIP TO	
ALL STATE AGENCIES VARIOUS LOCATIONS AS INDICATED BY ORDER		STATE OF WEST VIRGINIA VARIOUS LOCATIONS AS INDICATED BY ORDER	
No City	WV99999	No City	WV 99999
US		US	

Line	Commodity Line Description	Qty	Unit Issue	Unit Price	Total Price
3	SIDE (FENDER) PANELS	1.00000	EA	194.-	194.-

Commodity Code	Manufacturer	Model #	Specification
32101515	Work Area Protection	SCI	As specified by manufacturer + bid

Extended Description

WORK AREA PROTECTION/SCI PRODUCTS SMART CUSHION ATTENUATORS

SIDE (FENDER) PANELS

INTERMEDIARY SIDE PANEL (TO INCLUDE KEEPERS AND ANY OTHER REQUIRED HARDWARE FOR ATTACHEMENT)

DO NOT USE FOR SLED OR LAST BAY

PART DETAIL SHEET 63/64

INVOICE TO		SHIP TO	
ALL STATE AGENCIES VARIOUS LOCATIONS AS INDICATED BY ORDER		STATE OF WEST VIRGINIA VARIOUS LOCATIONS AS INDICATED BY ORDER	
No City	WV99999	No City	WV 99999
US		US	

Line	Commodity Line Description	Qty	Unit Issue	Unit Price	Total Price
4	SIDE (FENDER) PANELS	1.00000	EA	171.-	171.-

Commodity Code	Manufacturer	Model #	Specification
32101515	Work Area Protection	SCI	As specified by manufacturer + bid

Extended Description

WORK AREA PROTECTION/SCI PRODUCTS SMART CUSHION ATTENUATORS

SIDE (FENDER) PANELS

REAR BAY SIDE PANEL (IN CLUDE KEEPERS AND ANY OTHER REQUIRED HARDWARE FOR ATTACHMENT)

PART DETAIL SHEET 63/64

INVOICE TO		SHIP TO	
ALL STATE AGENCIES VARIOUS LOCATIONS AS INDICATED BY ORDER		STATE OF WEST VIRGINIA VARIOUS LOCATIONS AS INDICATED BY ORDER	
No City	WV99999	No City	WV 99999
US		US	

Line	Commodity Line Description	Qty	Unit Issue	Unit Price	Total Price
5	MOBILE FRAMES (DIAPHRAGMS)	1.00000	EA	375.-	375.-

Commodity Code	Manufacturer	Model #	Specification
32101515	Work Area Protection	SCI	As specified by manufacturer + bid

Extended Description
 WORK AREA PROTECTION/SCI PRODUCTS SMART CUSHION ATTENUATORS
 MOBILE FRAMES (DIAPHRAGMS)
 MOBILE FRAME #1 (1ST FRAME FOR TL-3 UNIT).
 TO INCLUDE SIDE GUIDES AND ANY REQUIRED HARDWARE.
 DO NOT USE IN TL-2 UNIT
 PART DETAIL SHEET 63/64

INVOICE TO		SHIP TO	
ALL STATE AGENCIES VARIOUS LOCATIONS AS INDICATED BY ORDER		STATE OF WEST VIRGINIA VARIOUS LOCATIONS AS INDICATED BY ORDER	
No City	WV99999	No City	WV 99999
US		US	

Line	Commodity Line Description	Qty	Unit Issue	Unit Price	Total Price
6	MOBILE FRAMES (DIAPHRAGMS)	1.00000	EA	375.-	375.-

Commodity Code	Manufacturer	Model #	Specification
32101515	Work Area Protection	SCI	As specified by manufacturer + bid

Extended Description
 WORK AREA PROTECTION/SCI PRODUCTS SMART CUSHION ATTENUATORS
 MOBILE FRAMES (DIAPHRAGMS)
 MOBILE FRAME #2 (2nd FRAME FOR TL-3 UNIT).
 TO INCLUDE SIDE GUIDES AND ANY REQUIRED HARDWARE.
 DO NOT USE IN TL-2 UNIT

INVOICE TO		SHIP TO	
ALL STATE AGENCIES VARIOUS LOCATIONS AS INDICATED BY ORDER		STATE OF WEST VIRGINIA VARIOUS LOCATIONS AS INDICATED BY ORDER	
No City	WV99999	No City	WV 99999
US		US	

Line	Commodity Line Description	Qty	Unit Issue	Unit Price	Total Price
7	MOBILE FRAMES (DIAPHRAGMS)	1.00000	EA	375.-	375.-

Commodity Code	Manufacturer	Model #	Specification
32101515	<i>Work Area Protection</i>	<i>SCI</i>	<i>As specified by manufacturer + bid</i>

Extended Description
 WORK AREA PROTECTION/SCI PRODUCTS SMART CUSHION ATTENUATORS
 MOBILE FRAMES (DIAPHRAGMS)
 MOBILE FRAME #3 (3RD FRAME FOR TL-3 UNIT).
 TO INCLUDE SIDE GUIDES AND ANY REQUIRED HARDWARE.
 DO NOT USE IN TL-2 UNIT
 PART DETAIL SHEET 63/64

INVOICE TO		SHIP TO	
ALL STATE AGENCIES VARIOUS LOCATIONS AS INDICATED BY ORDER		STATE OF WEST VIRGINIA VARIOUS LOCATIONS AS INDICATED BY ORDER	
No City	WV99999	No City	WV 99999
US		US	

Line	Commodity Line Description	Qty	Unit Issue	Unit Price	Total Price
8	MOBILE FRAMES (DIAPHRAGMS)	1.00000	EA	375.-	375.-

Commodity Code	Manufacturer	Model #	Specification
32101515	<i>Work Area Protection</i>	<i>SCI</i>	<i>As specified by manufacturer + bid</i>

Extended Description
 WORK AREA PROTECTION/SCI PRODUCTS SMART CUSHION ATTENUATORS
 MOBILE FRAMES (DIAPHRAGMS)
 MOBILE FRAME #4 (4th FRAME FOR TL-3 UNIT/ 1ST FRAME FOR TL-2 UNIT).
 TO INCLUDE SIDE GUIDES AND ANY REQUIRED HARDWARE.

INVOICE TO		SHIP TO	
ALL STATE AGENCIES VARIOUS LOCATIONS AS INDICATED BY ORDER		STATE OF WEST VIRGINIA VARIOUS LOCATIONS AS INDICATED BY ORDER	
No City	WV99999	No City	WV 99999
US		US	

Line	Commodity Line Description	Qty	Unit Issue	Unit Price	Total Price
9	MOBILE FRAMES (DIAPHRAGMS)	1.00000	EA	375.-	375.-

Commodity Code	Manufacturer	Model #	Specification
32101515	<i>Work Area Protection</i>	<i>SCI</i>	<i>As specified by manufacturer + bid</i>

Extended Description
 WORK AREA PROTECTION/SCI PRODUCTS SMART CUSHION ATTENUATORS
 MOBILE FRAMES (DIAPHRAGMS)
 MOBILE FRAME #5 (5th FRAME FOR TL-3 UNIT/ 2ND FRAME FOR TL-2 UNIT).
 TO INCLUDE SIDE GUIDES AND ANY REQUIRED HARDWARE.

INVOICE TO		SHIP TO	
ALL STATE AGENCIES VARIOUS LOCATIONS AS INDICATED BY ORDER		STATE OF WEST VIRGINIA VARIOUS LOCATIONS AS INDICATED BY ORDER	
No City	WV99999	No City	WV 99999
US		US	

Line	Commodity Line Description	Qty	Unit Issue	Unit Price	Total Price
10	MOBILE FRAMES (DIAPHRAGMS)	1.00000	EA	375.-	375.-

Commodity Code	Manufacturer	Model #	Specification
32101515	<i>Work Area Protection</i>	<i>SCI</i>	<i>As specified by manufacturer + bid</i>

Extended Description
 WORK AREA PROTECTION/SCI PRODUCTS SMART CUSHION ATTENUATORS
 MOBILE FRAMES (DIAPHRAGMS)
 MOBILE FRAME #6 (6th FRAME FOR TL-3 UNIT/ 3RD FRAME FOR TL-2 UNIT).
 TO INCLUDE SIDE GUIDES AND ANY REQUIRED HARDWARE.

INVOICE TO		SHIP TO	
ALL STATE AGENCIES VARIOUS LOCATIONS AS INDICATED BY ORDER		STATE OF WEST VIRGINIA VARIOUS LOCATIONS AS INDICATED BY ORDER	
No City	WV99999	No City	WV 99999
US		US	

Line	Commodity Line Description	Qty	Unit Issue	Unit Price	Total Price
11	FRONT (NOSE) COVERS	1.00000	EA	85.-	85.-

Commodity Code	Manufacturer	Model #	Specification
32101515	Work Area Protection	SCI	as specified by manufacturer's bid

Extended Description
 WORK AREA PROTECTION/SCI PRODUCTS SMART CUSHION ATTENUATORS
 FRONT (NOSE) COVERS
 FRONT COVER PANEL, YELLOW- TL-2 UNIT (FOR MOUNTING REFLECTIVE PANEL)

INVOICE TO		SHIP TO	
ALL STATE AGENCIES VARIOUS LOCATIONS AS INDICATED BY ORDER		STATE OF WEST VIRGINIA VARIOUS LOCATIONS AS INDICATED BY ORDER	
No City	WV99999	No City	WV 99999
US		US	

Line	Commodity Line Description	Qty	Unit Issue	Unit Price	Total Price
12	FRONT (NOSE) COVERS	1.00000	EA	85.-	85.-

Commodity Code	Manufacturer	Model #	Specification
32101515	Work Area Protection	SCI	as specified by manufacturer's bid

Extended Description
 WORK AREA PROTECTION/SCI PRODUCTS SMART CUSHION ATTENUATORS
 FRONT (NOSE) COVERS
 FRONT COVER PANEL, YELLOW- TL-3 UNIT (FOR MOUNTING REFLECTIVE PANEL)

INVOICE TO		SHIP TO	
ALL STATE AGENCIES VARIOUS LOCATIONS AS INDICATED BY ORDER		STATE OF WEST VIRGINIA VARIOUS LOCATIONS AS INDICATED BY ORDER	
No City	WV99999	No City	WV 99999
US		US	

Line	Commodity Line Description	Qty	Unit Issue	Unit Price	Total Price
13	FRONT SLEDS	1.00000	EA	1710.-	1710.-

Commodity Code	Manufacturer	Model #	Specification
32101515	Work Area Protection	SCI	as specified by manufacturer bid

Extended Description

WORK AREA PROTECTION/SCI PRODUCTS SMART CUSHION ATTENUATORS

FRONT SLEDS

FRONT SLED - TL2 UNIT (TO INCLUDE GUIDE ROLLERS AND ANY ADDITIONAL COMPONENTS/ HARDWARE REQUIRED FOR INSTALLATION)

PART DETAIL SHEETS 63/64

INVOICE TO		SHIP TO	
ALL STATE AGENCIES VARIOUS LOCATIONS AS INDICATED BY ORDER		STATE OF WEST VIRGINIA VARIOUS LOCATIONS AS INDICATED BY ORDER	
No City	WV99999	No City	WV 99999
US		US	

Line	Commodity Line Description	Qty	Unit Issue	Unit Price	Total Price
14	FRONT SLEDS	1.00000	EA	1810.-	1810.-

Commodity Code	Manufacturer	Model #	Specification
32101515	Work Area Protection	SCI	as specified by manufacturer bid

Extended Description

WORK AREA PROTECTION/SCI PRODUCTS SMART CUSHION ATTENUATORS

FRONT SLEDS

FRONT SLED - TL3 UNIT (TO INCLUDE GUIDE ROLLERS AND ANY ADDITIONAL COMPONENTS/ HARDWARE REQUIRED FOR INSTALLATION)

PART DETAIL SHEETS 63/64

INVOICE TO		SHIP TO	
ALL STATE AGENCIES VARIOUS LOCATIONS AS INDICATED BY ORDER		STATE OF WEST VIRGINIA VARIOUS LOCATIONS AS INDICATED BY ORDER	
No City	WV99999	No City	WV 99999
US		US	

Line	Commodity Line Description	Qty	Unit Issue	Unit Price	Total Price
15	SHEAVE TOOLS/COMPONENTS	1.00000	EA	145.80	145.80

Commodity Code	Manufacturer	Model #	Specification
32101515	Work Area Protection	SCI	as specified by manufacturer + bid

Extended Description
 WORK AREA PROTECTION/SCI PRODUCTS SMART CUSHION ATTENUATORS
 SHEAVE TOOLS/ COMPONENTS
 ANTI- ROTATION PIN REMOVAL TOOL

INVOICE TO		SHIP TO	
ALL STATE AGENCIES VARIOUS LOCATIONS AS INDICATED BY ORDER		STATE OF WEST VIRGINIA VARIOUS LOCATIONS AS INDICATED BY ORDER	
No City	WV99999	No City	WV 99999
US		US	

Line	Commodity Line Description	Qty	Unit Issue	Unit Price	Total Price
16	SHEAVE TOOLS/COMPONENTS	1.00000	EA	55.-	55.-

Commodity Code	Manufacturer	Model #	Specification
32101515	Work Area Protection	SCI	as specified by manufacturer + bid

Extended Description
 WORK AREA PROTECTION/SCI PRODUCTS SMART CUSHION ATTENUATORS
 SHEAVE TOOLS/ COMPONENTS
 FRONT SHEAVE ANTI - ROTATION PIN

INVOICE TO		SHIP TO	
ALL STATE AGENCIES VARIOUS LOCATIONS AS INDICATED BY ORDER		STATE OF WEST VIRGINIA VARIOUS LOCATIONS AS INDICATED BY ORDER	
No City	WV99999	No City	WV 99999
US		US	

Line	Commodity Line Description	Qty	Unit Issue	Unit Price	Total Price
17	SHEAVE TOOLS/COMPONENTS	1.00000	EA	55.-	55.-

Commodity Code	Manufacturer	Model #	Specification
32101515	Work Area Protection	SCI	as specified by manufacturer + bid

Extended Description
 WORK AREA PROTECTION/SCI PRODUCTS SMART CUSHION ATTENUATORS
 SHEAVE TOOLS/ COMPONENTS
 REAR SHEAVE ANTI-ROTATION PIN

INVOICE TO		SHIP TO	
ALL STATE AGENCIES VARIOUS LOCATIONS AS INDICATED BY ORDER		STATE OF WEST VIRGINIA VARIOUS LOCATIONS AS INDICATED BY ORDER	
No City	WV99999	No City	WV 99999
US		US	

Line	Commodity Line Description	Qty	Unit Issue	Unit Price	Total Price
18	SHEAVE TOOLS/COMPONENTS	1.00000	EA	30.25	30.25

Commodity Code	Manufacturer	Model #	Specification
32101515	Work Area Protection	SCI	as specified by manufacturer + bid

Extended Description
 WORK AREA PROTECTION/SCI PRODUCTS SMART CUSHION ATTENUATORS
 SHEAVE TOOLS/ COMPONENTS
 SHEAVE COVER PLATE (TO INCLUDE ATTACHMENT HARDWARE)

INVOICE TO		SHIP TO	
ALL STATE AGENCIES VARIOUS LOCATIONS AS INDICATED BY ORDER		STATE OF WEST VIRGINIA VARIOUS LOCATIONS AS INDICATED BY ORDER	
No City	WV99999	No City	WV 99999
US		US	

Line	Commodity Line Description	Qty	Unit Issue	Unit Price	Total Price
19	TRANSITIONS	1.00000	EA	1091. -	1091. -

Commodity Code	Manufacturer	Model #	Specification
32101515	Work Area Protection	SCI	as specified by manufacturer + bid

Extended Description
 WORK AREA PROTECTION/SCI PRODUCTS SMART CUSHION ATTENUATORS
 TRANSITIONS
 RIGHT SIDE JERSEY BARRIERS TRANSITION (TO INCLUDE ALL REQUIRED HARDWARE EXCLUDING ANCHOR BOLTS FOR COMPLETE INSTALLATION)
 PART DETAIL SHEET 65/66

INVOICE TO		SHIP TO	
ALL STATE AGENCIES VARIOUS LOCATIONS AS INDICATED BY ORDER		STATE OF WEST VIRGINIA VARIOUS LOCATIONS AS INDICATED BY ORDER	
No City	WV99999	No City	WV 99999
US		US	

Line	Commodity Line Description	Qty	Unit Issue	Unit Price	Total Price
20	TRANSITIONS	1.00000	EA	1091. -	1091. -

Commodity Code	Manufacturer	Model #	Specification
32101515	Work Area Protection	SCI	as specified by manufacturer + bid

Extended Description
 WORK AREA PROTECTION/SCI PRODUCTS SMART CUSHION ATTENUATORS
 TRANSITIONS
 LEFT SIDE JERSEY BARRIERS TRANSITION
 (TO INCLUDE ALL REQUIRED HARDWARE EXCLUDING ANCHOR BOLTS FOR COMPLETE INSTALLATION)
 PART DETAIL SHEET 65/66

INVOICE TO		SHIP TO	
ALL STATE AGENCIES VARIOUS LOCATIONS AS INDICATED BY ORDER		STATE OF WEST VIRGINIA VARIOUS LOCATIONS AS INDICATED BY ORDER	
No City	WV99999	No City	WV 99999
US		US	

Line	Commodity Line Description	Qty	Unit Issue	Unit Price	Total Price
21	TRANSITIONS	1.00000	EA	702.-	702.-

Commodity Code	Manufacturer	Model #	Specification
32101515	<i>Work Area Protection SCI as specified by manufacturer & bid</i>		

Extended Description
 WORK AREA PROTECTION/SCI PRODUCTS SMART CUSHION ATTENUATORS
 TRANSITIONS
 RIGHT SIDE 24" BLOCK TRANSITION
 (TO INCLUDE ALL REQUIRED HARDWARE EXCLUDING ANCHOR BOLTS FOR COMPLETE INSTALLATION)
 PART DETAIL SHEET 67/68

INVOICE TO		SHIP TO	
ALL STATE AGENCIES VARIOUS LOCATIONS AS INDICATED BY ORDER		STATE OF WEST VIRGINIA VARIOUS LOCATIONS AS INDICATED BY ORDER	
No City	WV99999	No City	WV 99999
US		US	

Line	Commodity Line Description	Qty	Unit Issue	Unit Price	Total Price
22	TRANSITIONS	1.00000	EA	702.-	702.-

Commodity Code	Manufacturer	Model #	Specification
32101515	<i>Work Area Protection SCI as specified by manufacturer + bid</i>		

Extended Description
 WORK AREA PROTECTION/SCI PRODUCTS SMART CUSHION ATTENUATORS
 TRANSITIONS
 LEFT SIDE 24" BLOCK TRANSITION
 (TO INCLUDE ALL REQUIRED HARDWARE EXCLUDING ANCHOR BOLTS FOR COMPLETE INSTALLATION)
 PART DETAIL SHEET 67/68

INVOICE TO		SHIP TO	
ALL STATE AGENCIES VARIOUS LOCATIONS AS INDICATED BY ORDER		STATE OF WEST VIRGINIA VARIOUS LOCATIONS AS INDICATED BY ORDER	
No City	WV99999	No City	WV 99999
US		US	

Line	Commodity Line Description	Qty	Unit Issue	Unit Price	Total Price
23	TRANSITIONS	1.00000	EA	915.-	915.-

Commodity Code	Manufacturer	Model #	Specification
32101515	Work Area Protection	SCI	As specified by manufacturer + bid

Extended Description
 WORK AREA PROTECTION/SCI PRODUCTS SMART CUSHION ATTENUATORS
 TRANSITIONS
 RIGHT SIDE 30" BLOCK STRAIGHT TRANSITION PANEL
 (TO INCLUDE ALL REQUIRED HARDWARE EXCLUDING ANCHOR BOLTS FOR COMPLETE INSTALLATION)
 PART DETAIL SHEET 69/70

INVOICE TO		SHIP TO	
ALL STATE AGENCIES VARIOUS LOCATIONS AS INDICATED BY ORDER		STATE OF WEST VIRGINIA VARIOUS LOCATIONS AS INDICATED BY ORDER	
No City	WV99999	No City	WV 99999
US		US	

Line	Commodity Line Description	Qty	Unit Issue	Unit Price	Total Price
24	TRANSITIONS	1.00000	EA	915.-	915.-

Commodity Code	Manufacturer	Model #	Specification
32101515	Work Area Protection	SCI	As specified by manufacturer + bid

Extended Description
 WORK AREA PROTECTION/SCI PRODUCTS SMART CUSHION ATTENUATORS
 TRANSITIONS
 LEFT SIDE 30" BLOCK STRAIGHT TRANSITION PANEL
 (TO INCLUDE ALL REQUIRED HARDWARE EXCLUDING ANCHOR BOLTS FOR COMPLETE INSTALLATION)
 PART DETAIL SHEET 69/70

INVOICE TO		SHIP TO	
ALL STATE AGENCIES VARIOUS LOCATIONS AS INDICATED BY ORDER		STATE OF WEST VIRGINIA VARIOUS LOCATIONS AS INDICATED BY ORDER	
No City	WV99999	No City	WV 99999
US		US	

Line	Commodity Line Description	Qty	Unit Issue	Unit Price	Total Price
25	TRANSITIONS	1.00000	EA	1215.-	1215.-

Commodity Code	Manufacturer	Model #	Specification
32101515	<i>Work Area Protection</i>	<i>SCI</i>	<i>As specified by manufacturer + bid</i>

Extended Description
 WORK AREA PROTECTION/SCI PRODUCTS SMART CUSHION ATTENUATORS
 TRANSITIONS
 RIGHT SIDE 36" BLOCK STRAIGHT TRANSITION PANEL
 (TO INCLUDE ALL REQUIRED HARDWARE EXCLUDING ANCHOR BOLTS FOR COMPLETE INSTALLATION)
 PART DETAIL SHEET 71/72

INVOICE TO		SHIP TO	
ALL STATE AGENCIES VARIOUS LOCATIONS AS INDICATED BY ORDER		STATE OF WEST VIRGINIA VARIOUS LOCATIONS AS INDICATED BY ORDER	
No City	WV99999	No City	WV 99999
US		US	

Line	Commodity Line Description	Qty	Unit Issue	Unit Price	Total Price
26	TRANSITIONS	1.00000	EA	1215.-	1215.-

Commodity Code	Manufacturer	Model #	Specification
32101515	<i>Work Area Protection</i>	<i>SCI</i>	<i>As specified by manufacturer + bid</i>

Extended Description
 WORK AREA PROTECTION/SCI PRODUCTS SMART CUSHION ATTENUATORS
 TRANSITIONS
 LEFT SIDE 36" BLOCK STRAIGHT TRANSITION PANEL
 (TO INCLUDE ALL REQUIRED HARDWARE EXCLUDING ANCHOR BOLTS FOR COMPLETE INSTALLATION)
 PART DETAIL SHEET 71/72

INVOICE TO		SHIP TO	
ALL STATE AGENCIES VARIOUS LOCATIONS AS INDICATED BY ORDER		STATE OF WEST VIRGINIA VARIOUS LOCATIONS AS INDICATED BY ORDER	
No City	WV99999	No City	WV 99999
US		US	

Line	Commodity Line Description	Qty	Unit Issue	Unit Price	Total Price
27	TRANSITIONS	1.00000	EA	1010.-	1010.-

Commodity Code	Manufacturer	Model #	Specification
32101515	Work Area Protection	SCI	As specified by manufacturer + bid

Extended Description

WORK AREA PROTECTION/SCI PRODUCTS SMART CUSHION ATTENUATORS

TRANSITIONS

RIGHT SIDE SCI TO THRIE RAIL TRANSITION

(TO INCLUDE HARDWARE REQUIRED FOR ATTACHING FIRST PANEL OF TRANSITION TO LAST SCI PANEL)

PART DETAIL SHEET 73/74

INVOICE TO		SHIP TO	
ALL STATE AGENCIES VARIOUS LOCATIONS AS INDICATED BY ORDER		STATE OF WEST VIRGINIA VARIOUS LOCATIONS AS INDICATED BY ORDER	
No City	WV99999	No City	WV 99999
US		US	

Line	Commodity Line Description	Qty	Unit Issue	Unit Price	Total Price
28	TRANSITIONS	1.00000	EA	1010.-	1010.-

Commodity Code	Manufacturer	Model #	Specification
32101515	Work Area Protection	SCI	As specified by manufacturer + bid

Extended Description

WORK AREA PROTECTION/SCI PRODUCTS SMART CUSHION ATTENUATORS

TRANSITIONS

LEFT SIDE SCI TO THRIE RAIL TRANSITION

(TO INCLUDE HARDWARE REQUIRED FOR ATTACHING FIRST PANEL OF TRANSITION TO LAST SCI PANEL)

INVOICE TO		SHIP TO	
ALL STATE AGENCIES VARIOUS LOCATIONS AS INDICATED BY ORDER		STATE OF WEST VIRGINIA VARIOUS LOCATIONS AS INDICATED BY ORDER	
No City	WV99999	No City	WV 99999
US		US	

Line	Commodity Line Description	Qty	Unit Issue	Unit Price	Total Price
29	TRANSITIONS	1.00000	EA	1228.-	1228.-

Commodity Code	Manufacturer	Model #	Specification
32101515	Work Area Protection	SCI	As specified by manufacturer + bid

Extended Description

WORK AREA PROTECTION/SCI PRODUCTS SMART CUSHION ATTENUATORS

TRANSITIONS

RIGHT SIDE SCI TO W-BEAM RAIL TRANSITION

(TO INCLUDE HARDWARE REQUIRED FOR ATTACHING FIRST PANEL OF TRANSITION TO LAST SCI PANEL)

TO ALSO INCLUDE INTERMEDIARY THRIE BEAM TRANSITION

PART DETAIL SHEET 75/76

INVOICE TO		SHIP TO	
ALL STATE AGENCIES VARIOUS LOCATIONS AS INDICATED BY ORDER		STATE OF WEST VIRGINIA VARIOUS LOCATIONS AS INDICATED BY ORDER	
No City	WV99999	No City	WV 99999
US		US	

Line	Commodity Line Description	Qty	Unit Issue	Unit Price	Total Price
30	TRANSITIONS	1.00000	EA	1228.-	1228.-

Commodity Code	Manufacturer	Model #	Specification
32101515	Work Area Protection	SCI	As specified by Manufacturer + bid

Extended Description

WORK AREA PROTECTION/SCI PRODUCTS SMART CUSHION ATTENUATORS

TRANSITIONS

LEFT SIDE SCI TO W-BEAM RAIL TRANSITION

(TO INCLUDE HARDWARE REQUIRED FOR ATTACHING FIRST PANEL OF TRANSITION TO LAST SCI PANEL)

TO ALSO INCLUDE INTERMEDIARY THRIE BEAM TRANSITION

PART DETAIL SHEET 75/76

INVOICE TO		SHIP TO	
ALL STATE AGENCIES VARIOUS LOCATIONS AS INDICATED BY ORDER		STATE OF WEST VIRGINIA VARIOUS LOCATIONS AS INDICATED BY ORDER	
No City	WV99999	No City	WV 99999
US		US	

Line	Commodity Line Description	Qty	Unit Issue	Unit Price	Total Price
31	TRANSITIONS	1.00000	EA	1181.-	1181.-

Commodity Code	Manufacturer	Model #	Specification
32101515	work Area Protection	SCI	As specified by manufacturer + bid

Extended Description

WORK AREA PROTECTION/SCI PRODUCTS SMART CUSHION ATTENUATORS

TRANSITIONS

RIGHT SIDE STRAIGHT SLOPE BARRIER TRANSITION

(TO INCLUDE ALL REQUIRED HARDWARE EXCLUDING ANCHOR BOLTS FOR COMPLETE INSTALLATION)

PART DETAIL SHEET 77/78

INVOICE TO		SHIP TO	
ALL STATE AGENCIES VARIOUS LOCATIONS AS INDICATED BY ORDER		STATE OF WEST VIRGINIA VARIOUS LOCATIONS AS INDICATED BY ORDER	
No City	WV99999	No City	WV 99999
US		US	

Line	Commodity Line Description	Qty	Unit Issue	Unit Price	Total Price
32	TRANSITIONS	1.00000	EA	1181.-	1181.-

Commodity Code	Manufacturer	Model #	Specification
32101515	Work Area Protection	SCI	As specified by manufacturer + bid

Extended Description

WORK AREA PROTECTION/SCI PRODUCTS SMART CUSHION ATTENUATORS

TRANSITIONS

LEFT SIDE STRAIGHT SLOPE BARRIER TRANSITION

(TO INCLUDE ALL REQUIRED HARDWARE EXCLUDING ANCHOR BOLTS FOR COMPLETE INSTALLATION)

PART DETAIL SHEET 77/78

INVOICE TO		SHIP TO	
ALL STATE AGENCIES VARIOUS LOCATIONS AS INDICATED BY ORDER		STATE OF WEST VIRGINIA VARIOUS LOCATIONS AS INDICATED BY ORDER	
No City	WV99999	No City	WV 99999
US		US	

Line	Commodity Line Description	Qty	Unit Issue	Unit Price	Total Price
33	COMPLETE UNITS	1.00000	EA	15,000. —	15,000. —

Commodity Code	Manufacturer	Model #	Specification
32101515	<i>Work Area Protection</i>	<i>SCI</i>	<i>As specified by manufacturer + bid</i>

Extended Description
 WORK AREA PROTECTION/SCI PRODUCTS SMART CUSHION ATTENUATORS
 COMPLETE UNITS
 WORKAREA PROTECTION SCI SMART CUSHION SCI70GM-CA UNIT, NCHRP-350 TEST LEVEL 2, 24" WIDTH, TO BE DELIVERED PRE-ASSEMBLED
 (TO INCLUDE ALL ANCHORING STUDS AND ANCHORING STUD EPOXY REQUIRED FOR INSTALLATION)

INVOICE TO		SHIP TO	
ALL STATE AGENCIES VARIOUS LOCATIONS AS INDICATED BY ORDER		STATE OF WEST VIRGINIA VARIOUS LOCATIONS AS INDICATED BY ORDER	
No City	WV99999	No City	WV 99999
US		US	

Line	Commodity Line Description	Qty	Unit Issue	Unit Price	Total Price
34	COMPLETE UNITS	1.00000	EA	15,000. —	15,000. —

Commodity Code	Manufacturer	Model #	Specification
32101515	<i>Work Area Protection</i>	<i>SCI</i>	<i>As specified by manufacturer + bid</i>

Extended Description
 WORK AREA PROTECTION/SCI PRODUCTS SMART CUSHION ATTENUATORS
 COMPLETE UNITS
 WORKAREA PROTECTION SCI SMART CUSHION SCI100GM-CA UNIT, NCHRP-350 TEST LEVEL 3, 24" WIDTH, TO BE DELIVERED PRE-ASSEMBLED
 (TO INCLUDE ALL ANCHORING STUDS AND ANCHORING STUD EPOXY REQUIRED FOR INSTALLATION)
 THIS ITEMS MAY ONLY BE ORDERED BY THE TRAFFIC ENGINEERING DIVISION

DOT1600000007	Document Phase Final	Document Description WORK AREA PROTECT IMPACT ATTEN UATOR PARTS	Page 19 of 24
---------------	--------------------------------	--	-------------------------

**GENERAL TERMS AND CONDITIONS:
(Agency Delegated Procurement Only)**

1. **CONTRACTUAL AGREEMENT:** Issuance of a Purchase Order signed by the Agency, and approved as to form by the Attorney General's office if required, constitutes acceptance of this Contract made by and between the State of West Virginia and the Vendor. Vendor's signature on its bid signifies Vendor's agreement to be bound by and accept the terms and conditions contained in this Contract.

2. **DEFINITIONS:** As used in this Solicitation / Contract, the following terms shall have the meanings attributed to them below. Additional definitions may be found in the specifications included with this Solicitation / Contract.

2.1 "Agency" means the agency, board, commission, or other entity of the State of West Virginia that is identified on the first page of the Solicitation.

2.2 "Contract" means the binding agreement that is entered into between the State and the Vendor to provide the goods and services requested in the Solicitation.

2.3 "Director" means the Director of the West Virginia Department of Administration, Purchasing Division.

2.4 "Purchasing Division" means the West Virginia Department of Administration, Purchasing Division.

2.5 "Purchase Order" means the document signed by the Agency and the Purchasing Division, and approved as to form by the Attorney General, that identifies the Vendor as the successful bidder and Contract holder. Notwithstanding the foregoing, the Purchasing Division's signature and approval by the Attorney General's office as to form may not be required on a Purchase Order for certain agency delegated purchases.

2.6 "Solicitation" means the official solicitation issued by the Agency.

2.7 "State" means the State of West Virginia and/or any of its agencies, commissions, boards, etc. as context requires.

2.8 "Vendor" or "Vendors" means any entity submitting a bid in response to the Solicitation, the entity that has been selected as the lowest responsible bidder, or the entity that has been awarded the Contract as context requires.

3. **PRICING:** The pricing set forth herein is firm for the life of the Contract, unless specified elsewhere within this Solicitation/Contract by the State. A Vendor's inclusion of price adjustment provisions in its bid, without an express authorization from the State in the Solicitation to do so, may result in bid disqualification.

4. **NOTICE TO PROCEED:** The Vendor shall begin performance of this Contract immediately upon receiving notice to proceed. Unless otherwise specified, the fully executed Purchase Order will be considered notice to proceed.

5. **EMERGENCY PURCHASES:** The Purchasing Division Director may authorize the Agency to purchase goods or services in the open market that Vendor would otherwise provide under this Contract if those goods or services are for immediate or expedited delivery in an emergency. Emergencies shall include, but are not limited to, delays in transportation or an unanticipated increase in the volume of work. An emergency purchase in the open market, approved by the Purchasing Division Director, shall not constitute of breach of this Contract and shall not entitle the Vendor to any form of compensation or damages. This provision does not excuse the State from fulfilling its obligations under a One Time Purchase contract.

6. **ALTERNATES:** Any model, brand, or specification listed herein establishes the acceptable level of quality only and is not intended to reflect a preference for, or in any way favor, a particular brand or vendor. Vendors may bid alternates to a listed model or brand provided that the alternate is at least equal to the model or brand and complies with the required specifications. The equality of any alternate being bid shall be determined by the State at its sole discretion. Any Vendor bidding an alternate model or brand should clearly identify the alternate items in its bid and should include manufacturer's specifications, industry literature, and/or any other relevant documentation demonstrating the equality of the

DOT160000007	Document Phase Final	Document Description WORK AREA PROTECT IMPACT ATTEN UATOR PARTS	Page 20 of 24
--------------	--------------------------------	--	-------------------------

alternate items. Failure to provide information for alternate items may be grounds for rejection of a Vendor's bid.

7. EXCEPTIONS AND CLARIFICATIONS: The Solicitation contains the specifications that shall form the basis of a contractual agreement. Vendor shall clearly mark any exceptions, clarifications, or other proposed modifications in its bid. Exceptions to, clarifications of, or modifications of a requirement or term and condition of the Solicitation may result in bid disqualification.

8. ACCEPTANCE/REJECTION: The State may accept or reject any bid in whole, or in part. Vendor's signature on its bid signifies acceptance of the terms and conditions contained in the Solicitation and Vendor agrees to be bound by the terms of the Contract, as reflected in the Purchase Order, upon receipt.

9. REGISTRATION: Prior to Contract award, the apparent successful Vendor must be properly registered with the West Virginia Purchasing Division and must have paid the \$125 fee if applicable.

10. FUNDING: This Contract shall continue for the term stated herein, contingent upon funds being appropriated by the Legislature or otherwise being made available. In the event funds are not appropriated or otherwise made available, this Contract becomes void and of no effect beginning on July 1 of the fiscal year for which funding has not been appropriated or otherwise made available.

11. PAYMENT: Payment in advance is prohibited under this Contract. Payment may only be made after the delivery and acceptance of goods or services. The Vendor shall submit invoices, in arrears, to the Agency at the address on the face of the purchase order labeled "Invoice To."

12. UNIT PRICE: Unit prices shall prevail in cases of a discrepancy in the Vendor's bid.

13. DELIVERY: All quotations are considered freight on board destination ("F.O.B. destination") unless alternate shipping terms are clearly identified in the bid. Vendor's listing of shipping terms that contradict the shipping terms expressly required by this Solicitation may result in bid disqualification.

14. INTEREST: Interest attributable to late payment will only be permitted if authorized by the West Virginia Code. Presently, there is no provision in the law for interest on late payments.

15. PREFERENCE: Vendor Preference may only be granted upon written request and only in accordance with the West Virginia Code § 5A-3-37 and the West Virginia Code of State Rules. A Resident Vendor Certification form has been attached hereto to allow Vendor to apply for the preference. Vendor's failure to submit the Resident Vendor Certification form with its bid will result in denial of Vendor Preference. Vendor Preference does not apply to construction projects.

16. SMALL, WOMEN-OWNED, OR MINORITY-OWNED BUSINESSES: For any solicitations publicly advertised for bid on or after July 1, 2012, in accordance with West Virginia Code §5A-3-37(a) (7) and W. Va. CSR § 148-22-9, any non-resident vendor certified as a small, women-owned, or minority-owned business under W. Va. CSR § 148-22-9 shall be provided the same preference made available to any resident vendor. Any non-resident small, women-owned, or minority-owned business must identify itself as such in writing, must submit that writing to the Purchasing Division (or to the Agency handling the solicitation for agency delegated purchases) with its bid, and must be properly certified under W. Va. CSR § 148-22-9 prior to submission of its bid to receive the preferences made available to resident vendors. Preference for a non-resident small, women-owned, or minority-owned business shall be applied in accordance with W. Va. CSR § 148-22-9.

17. TAXES: The Vendor shall pay any applicable sales, use, personal property or any other taxes arising out of this Contract and the transactions contemplated thereby. The State of West Virginia is exempt from federal and state taxes and will not pay or reimburse such taxes.

18. CANCELLATION: The State reserves the right to cancel this Contract immediately upon written notice to the vendor if the materials or workmanship supplied do not conform to the specifications contained in the Contract. The Purchasing Division Director may cancel any purchase or Contract upon 30 days written notice to the Vendor in accordance with West Virginia Code of State Rules § 148-1-7.16.2.

19. WAIVER OF MINOR IRREGULARITIES: The Director reserves the right to waive minor irregularities in bids or specifications in accordance with West Virginia Code of State Rules § 148-1-4.6.

	Document Phase	Document Description	Page
DOT160000007	Final	WORK AREA PROTECT IMPACT ATTEN UATOR PARTS	21 of 24

20. **TIME:** Time is of the essence with regard to all matters of time and performance in this Contract.

21. **APPLICABLE LAW:** This Contract is governed by and interpreted under West Virginia law without giving effect to its choice of law principles. Any information provided in specification manuals, or any other source, verbal or written, which contradicts or violates the West Virginia Constitution, West Virginia Code or West Virginia Code of State Rules is void and of no effect.

22. **COMPLIANCE:** Vendor shall comply with all applicable federal, state, and local laws, regulations and ordinances. By submitting a bid, Vendors acknowledge that they have reviewed, understand, and will comply with all applicable law.

23. **PREVAILING WAGE:** On any contract for the construction of a public improvement, Vendor and any subcontractors utilized by Vendor shall pay a rate or rates of wages which shall not be less than the fair minimum rate or rates of wages (prevailing wage), as established by the West Virginia Division of Labor under West Virginia Code §§ 21-5A-1 et seq. and available at <http://www.sos.wv.gov/administrative-law/wagerates/Pages/default.aspx>. Vendor shall be responsible for ensuring compliance with prevailing wage requirements and determining when prevailing wage requirements are applicable. The required contract provisions contained in West Virginia Code of State Rules § 42-7-3 are specifically incorporated herein by reference.

24. **ARBITRATION:** Any references made to arbitration contained in this Contract, Vendor's bid, or in any American Institute of Architects documents pertaining to this Contract are hereby deleted, void, and of no effect.

25. **MODIFICATIONS:** This writing is the parties' final expression of intent. Notwithstanding anything contained in this Contract to the contrary, no modification of this Contract shall be binding without mutual written consent of the Agency, and the Vendor, with approval of the Purchasing Division and the Attorney General's office (Attorney General approval is as to form only). No Change shall be implemented by the Vendor until such time as the Vendor receives an approved written change order from the Purchasing Division. Notwithstanding the foregoing, Purchasing Division and Attorney General approval may or may not be required on certain agency delegated or exempt purchases. In the event that Purchasing Division approval is not required, change orders will be received from the Agency.

26. **WAIVER:** The failure of either party to insist upon a strict performance of any of the terms or provision of this Contract, or to exercise any option, right, or remedy herein contained, shall not be construed as a waiver or a relinquishment for the future of such term, provision, option, right, or remedy, but the same shall continue in full force and effect. Any waiver must be expressly stated in writing and signed by the waiving party.

27. **SUBSEQUENT FORMS:** The terms and conditions contained in this Contract shall supersede any and all subsequent terms and conditions which may appear on any form documents submitted by Vendor to the Agency or Purchasing Division such as price lists, order forms, invoices, sales agreements, or maintenance agreements, and includes internet websites or other electronic documents. Acceptance or use of Vendor's forms does not constitute acceptance of the terms and conditions contained thereon.

28. **ASSIGNMENT:** Neither this Contract nor any monies due, or to become due hereunder, may be assigned by the Vendor without the express written consent of the Agency, the Purchasing Division, the Attorney General's office (as to form only), and any other government agency or office that may be required to approve such assignments. Notwithstanding the foregoing, Purchasing Division approval may or may not be required on certain agency delegated or exempt purchases.

29. **WARRANTY:** The Vendor expressly warrants that the goods and/or services covered by this Contract will: (a) conform to the specifications, drawings, samples, or other description furnished or specified by the Agency; (b) be merchantable and fit for the purpose intended; and (c) be free from defect in material and workmanship.

30. **STATE EMPLOYEES:** State employees are not permitted to utilize this Contract for personal use and the Vendor is prohibited from permitting or facilitating the same.

31. **BANKRUPTCY:** In the event the Vendor files for bankruptcy protection, the State of West Virginia may deem this Contract null and void, and terminate this Contract without notice.

32. [RESERVED]

DOT160000007	Document Phase Final	Document Description WORK AREA PROTECT IMPACT ATTEN UATOR PARTS	Page 22 of 24
--------------	--------------------------------	--	-------------------------

33. **CONFIDENTIALITY:** The Vendor agrees that it will not disclose to anyone, directly or indirectly, any such personally identifiable information or other confidential information gained from the Agency, unless the individual who is the subject of the information consents to the disclosure in writing or the disclosure is made pursuant to the Agency's policies, procedures, and rules. Vendor further agrees to comply with the Confidentiality Policies and Information Security Accountability Requirements, set forth in <http://www.state.wv.us/admin/purchase/privacy/default.html>.

34. **DISCLOSURE:** Vendor's response to the Solicitation and the resulting Contract are considered public documents and will be disclosed to the public in accordance with the laws, rules, and policies governing the West Virginia Purchasing Division. Those laws include, but are not limited to, the Freedom of Information Act found in West Virginia Code § 29B-1-1 et seq.

If a Vendor considers any part of its bid to be exempt from public disclosure, Vendor must so indicate by specifically identifying the exempt information, identifying the exemption that applies, providing a detailed justification for the exemption, segregating the exempt information from the general bid information, and submitting the exempt information as part of its bid but in a segregated and clearly identifiable format. Failure to comply with the foregoing requirements will result in public disclosure of the Vendor's bid without further notice. A Vendor's act of marking all or nearly all of its bid as exempt is not sufficient to avoid disclosure and WILL NOT BE HONORED. Vendor's act of marking a bid or any part thereof as "confidential" or "proprietary" is not sufficient to avoid disclosure and WILL NOT BE HONORED. In addition, a legend or other statement indicating that all or substantially all of the bid is exempt from disclosure is not sufficient to avoid disclosure and WILL NOT BE HONORED. Vendor will be required to defend any claimed exemption for nondisclosure in the event of an administrative or judicial challenge to the State's nondisclosure. Vendor must indemnify the State for any costs incurred related to any exemptions claimed by Vendor. Any questions regarding the applicability of the various public records laws should be addressed to your own legal counsel prior to bid submission.

35. **LICENSING:** In accordance with West Virginia Code of State Rules §148-1-6.1.7, Vendor must be licensed and in good standing in accordance with any and all state and local laws and requirements by any state or local agency of West Virginia, including, but not limited to, the West Virginia Secretary of State's Office, the West Virginia Tax Department, West Virginia Insurance Commission, or any other state agency or political subdivision. Upon request, the Vendor must provide all necessary releases to obtain information to enable the Purchasing Division Director or the Agency to verify that the Vendor is licensed and in good standing with the above entities.

36. **ANTITRUST:** In submitting a bid to, signing a contract with, or accepting a Purchase Order from any agency of the State of West Virginia, the Vendor agrees to convey, sell, assign, or transfer to the State of West Virginia all rights, title, and interest in and to all causes of action it may now or hereafter acquire under the antitrust laws of the United States and the State of West Virginia for price fixing and/or unreasonable restraints of trade relating to the particular commodities or services purchased or acquired by the State of West Virginia. Such assignment shall be made and become effective at the time the purchasing agency tenders the initial payment to Vendor.

37. **VENDOR CERTIFICATIONS:** By signing its bid or entering into this Contract, Vendor certifies (1) that its bid was made without prior understanding, agreement, or connection with any corporation, firm, limited liability company, partnership, person or entity submitting a bid for the same material, supplies, equipment or services; (2) that its bid is in all respects fair and without collusion or fraud; (3) that this Contract is accepted or entered into without any prior understanding, agreement, or connection to any other entity that could be considered a violation of law; and (4) that it has reviewed this RFQ in its entirety; understands the requirements, terms and conditions, and other information contained herein. Vendor's signature on its bid also affirms that neither it nor its representatives have any interest, nor shall acquire any interest, direct or indirect, which would compromise the performance of its services hereunder. Any such interests shall be promptly presented in detail to the Agency.

The individual signing this bid on behalf of Vendor certifies that he or she is authorized by the Vendor to execute this bid or any documents related thereto on Vendor's behalf; that he or she is authorized to bind the Vendor in a contractual relationship; and that, to the best of his or her knowledge, the Vendor has properly registered with any State agency that may require registration.

38. **PURCHASING CARD ACCEPTANCE:** The State of West Virginia currently utilizes a Purchasing Card program, administered under contract by a banking institution, to process payment for goods and services. The Vendor must accept the State of West Virginia's Purchasing Card for payment of all orders under this Contract.

39. **VENDOR RELATIONSHIP:** The relationship of the Vendor to the State shall be that of an independent contractor and no principal-agent

DOT160000007	Document Phase Final	Document Description WORK AREA PROTECT IMPACT ATTEN UATOR PARTS	Page 23 of 24
--------------	--------------------------------	--	-------------------------

relationship or employer-employee relationship is contemplated or created by this Contract. The Vendor as an independent contractor is solely liable for the acts and omissions of its employees and agents. Vendor shall be responsible for selecting, supervising, and compensating any and all individuals employed pursuant to the terms of this Solicitation and resulting contract. Neither the Vendor, nor any employees or subcontractors of the Vendor, shall be deemed to be employees of the State for any purpose whatsoever. Vendor shall be exclusively responsible for payment of employees and contractors for all wages and salaries, taxes, withholding payments, penalties, fees, fringe benefits, professional liability insurance premiums, contributions to insurance and pension, or other deferred compensation plans, including but not limited to, Workers' Compensation and Social Security obligations, licensing fees, etc. and the filing of all necessary documents, forms and returns pertinent to all of the foregoing. Vendor shall hold harmless the State, and shall provide the State and Agency with a defense against any and all claims including, but not limited to, the foregoing payments, withholdings, contributions, taxes, Social Security taxes, and employer income tax returns.

40. **INDEMNIFICATION:** The Vendor agrees to indemnify, defend, and hold harmless the State and the Agency, their officers, and employees from and against: (1) Any claims or losses for services rendered by any subcontractor, person, or firm performing or supplying services, materials, or supplies in connection with the performance of the Contract; (2) Any claims or losses resulting to any person or entity injured or damaged by the Vendor, its officers, employees, or subcontractors by the publication, translation, reproduction, delivery, performance, use, or disposition of any data used under the Contract in a manner not authorized by the Contract, or by Federal or State statutes or regulations; and (3) Any failure of the Vendor, its officers, employees, or subcontractors to observe State and Federal laws including, but not limited to, labor and wage and hour laws.

41. **PURCHASING AFFIDAVIT:** In accordance with West Virginia Code § 5A-3-10a, all Vendors are required to sign, notarize, and submit the Purchasing Affidavit stating that neither the Vendor nor a related party owe a debt to the State in excess of \$1,000. The affidavit must be submitted prior to award, but should be submitted with the Vendor's bid. A copy of the Purchasing Affidavit is included herewith.

42. **CONFLICT OF INTEREST:** Vendor, its officers or members or employees, shall not presently have or acquire any interest, direct or indirect, which would conflict with or compromise the performance of its obligations hereunder. Vendor shall periodically inquire of its officers, members and employees to ensure that a conflict of interest does not arise. Any conflict of interest discovered shall be promptly presented in detail to the Agency.

43. **BACKGROUND CHECK:** In accordance with W. Va. Code § 15-2D-3, the Director of the Division of Protective Services shall require any service provider whose employees are regularly employed on the grounds or in the buildings of the Capitol complex or who have access to sensitive or critical information to submit to a fingerprint-based state and federal background inquiry through the state repository. The service provider is responsible for any costs associated with the fingerprint-based state and federal background inquiry

After the contract for such services has been approved, but before any such employees are permitted to be on the grounds or in the buildings of the Capitol complex or have access to sensitive or critical information, the service provider shall submit a list of all persons who will be physically present and working at the Capitol complex to the Director of the Division of Protective Services for purposes of verifying compliance with this provision.

The State reserves the right to prohibit a service provider's employees from accessing sensitive or critical information or to be present at the Capitol complex based upon results addressed from a criminal background check.

Service providers should contact the West Virginia Division of Protective Services by phone at (304) 558-9911 for more information.

44. **PREFERENCE FOR USE OF DOMESTIC STEEL PRODUCTS:** Except when authorized by the Director of the Purchasing Division pursuant to W. Va. Code § 5A-3-56, no contractor may use or supply steel products for a State Contract Project other than those steel products made in the United States. A contractor who uses steel products in violation of this section may be subject to civil penalties pursuant to W. Va. Code § 5A-3-56. As used in this section:

- a. "State Contract Project" means any erection or construction of, or any addition to, alteration of or other improvement to any building or structure, including, but not limited to, roads or highways, or the installation of any heating or cooling or ventilating plants or other equipment, or the supply of and materials for such projects, pursuant to a contract with the State of West Virginia for which bids were solicited on or after June 6, 2001.

DOT160000007	Document Phase Final	Document Description WORK AREA PROTECT IMPACT ATTEN UATOR PARTS	Page 24 of 24
--------------	--------------------------------	--	----------------------------

b. "Steel Products" means products rolled, formed, shaped, drawn, extruded, forged, cast, fabricated or otherwise similarly processed, or processed by a combination of two or more of such operations, from steel made by the open hearth, basic oxygen, electric furnace, Bessemer or other steel making process.

The Purchasing Division Director may, in writing, authorize the use of foreign steel products if:

a. The cost for each contract item used does not exceed one tenth of one percent (.1%) of the total contract cost or two thousand five hundred dollars (\$2,500.00), whichever is greater. For the purposes of this section, the cost is the value of the steel product as delivered to the project; or

b. The Director of the Purchasing Division determines that specified steel materials are not produced in the United States in sufficient quantity or otherwise are not reasonably available to meet contract requirements.

45. PREFERENCE FOR USE OF DOMESTIC ALUMINUM, GLASS, AND STEEL: In Accordance with W. Va. Code § 5-19-1 et seq., and W. Va. CSR § 148-10-1 et seq., for every contract or subcontract, subject to the limitations contained herein, for the construction, reconstruction, alteration, repair, improvement or maintenance of public works or for the purchase of any item of machinery or equipment to be used at sites of public works, only domestic aluminum, glass or steel products shall be supplied unless the spending officer determines, in writing, after the receipt of offers or bids, (1) that the cost of domestic aluminum, glass or steel products is unreasonable or inconsistent with the public interest of the State of West Virginia, (2) that domestic aluminum, glass or steel products are not produced in sufficient quantities to meet the contract requirements, or (3) the available domestic aluminum, glass, or steel do not meet the contract specifications. This provision only applies to public works contracts awarded in an amount more than fifty thousand dollars (\$50,000) or public works contracts that require more than ten thousand pounds of steel products.

The cost of domestic aluminum, glass, or steel products may be unreasonable if the cost is more than twenty percent (20%) of the bid or offered price for foreign made aluminum, glass, or steel products. If the domestic aluminum, glass or steel products to be supplied or produced in a "substantial labor surplus area", as defined by the United States Department of Labor, the cost of domestic aluminum, glass, or steel products may be unreasonable if the cost is more than thirty percent (30%) of the bid or offered price for foreign made aluminum, glass, or steel products.

This preference shall be applied to an item of machinery or equipment, as indicated above, when the item is a single unit of equipment or machinery manufactured primarily of aluminum, glass or steel, is part of a public works contract and has the sole purpose or of being a permanent part of a single public works project. This provision does not apply to equipment or machinery purchased by a spending unit for use by that spending unit and not as part of a single public works project.

All bids and offers including domestic aluminum, glass or steel products that exceed bid or offer prices including foreign aluminum, glass or steel products after application of the preferences provided in this provision may be reduced to a price equal to or lower than the lowest bid or offer price for foreign aluminum, glass or steel products plus the applicable preference. If the reduced bid or offer prices are made in writing and supersede the prior bid or offer prices, all bids or offers, including the reduced bid or offer prices, will be reevaluated in accordance with this rule.

INSTRUCTIONS TO VENDORS SUBMITTING BIDS
(Agency Delegated Procurements Only)

1. **REVIEW DOCUMENTS THOROUGHLY:** The attached documents contain a solicitation for bids. Please read these instructions and all documents attached in their entirety. These instructions provide critical information about requirements that if overlooked could lead to disqualification of a Vendor's bid. All bids must be submitted in accordance with the provisions contained in these instructions and the Solicitation. Failure to do so may result in disqualification of Vendor's bid.
2. **MANDATORY TERMS:** The Solicitation may contain mandatory provisions identified by the use of the words "must," "will," and "shall." Failure to comply with a mandatory term in the Solicitation will result in bid disqualification.
3. **BID SUBMISSION:** All bids must be submitted electronically through wvOASIS or signed and delivered by the Vendor to the Agency on or before the date and time of the bid opening. Any bid received by the Agency staff is considered to be in the possession of the Agency and will not be returned for any reason.
4. **ADDENDUM ACKNOWLEDGEMENT:** Changes or revisions to this Solicitation will be made by an official addendum issued by the Agency. Vendor should acknowledge receipt of all addenda issued with this Solicitation by completing an Addendum Acknowledgment Form, a copy of which is included herewith. Failure to acknowledge addenda may result in bid disqualification. The addendum acknowledgement should be submitted with the bid to expedite document processing.
5. **BID FORMATTING:** Vendor should type or electronically enter the information onto its bid to prevent errors in the evaluation. Failure to type or electronically enter the information may result in bid disqualification.
6. **ALTERNATES:** Any model, brand, or specification listed in this Solicitation establishes the acceptable level of quality only and is not intended to reflect a preference for, or in any way favor, a particular brand or vendor. Vendors may bid alternates to a listed model or brand provided that the alternate is at least equal to the model or brand and complies with the required specifications. The equality of any alternate being bid shall be determined by the State at its sole discretion. Any Vendor bidding an alternate model or brand should clearly identify the alternate items in its bid and should include manufacturer's specifications, industry literature, and/or any other relevant documentation demonstrating the equality of the alternate items. Failure to provide information for alternate items may be grounds for rejection of a Vendor's bid.
7. **EXCEPTIONS AND CLARIFICATIONS:** The Solicitation contains the specifications that shall form the basis of a contractual agreement. Vendor shall clearly mark any exceptions, clarifications, or other proposed modifications in its bid. Exceptions to, clarifications of, or

modifications of a requirement or term and condition of the Solicitation may result in bid disqualification.

- 8. REGISTRATION:** Prior to Contract award, the apparent successful Vendor must be properly registered with the West Virginia Purchasing Division and must have paid the \$125 fee, if applicable.
- 9. UNIT PRICE:** Unit prices shall prevail in cases of a discrepancy in the Vendor's bid.
- 10. PREFERENCE:** Vendor Preference may only be granted upon written request and only in accordance with the West Virginia Code § 5A-3-37 and the West Virginia Code of State Rules. A Vendor Preference Certificate form has been attached hereto to allow Vendor to apply for the preference. Vendor's failure to submit the Vendor Preference Certificate form with its bid will result in denial of Vendor Preference. Vendor Preference does not apply to construction projects.
- 11. SMALL, WOMEN-OWNED, OR MINORITY-OWNED BUSINESSES:** For any solicitations publicly advertised for bid, in accordance with West Virginia Code §5A-3-37(a)(7) and W. Va. CSR § 148-22-9, any non-resident vendor certified as a small, women-owned, or minority-owned business under W. Va. CSR § 148-22-9 shall be provided the same preference made available to any resident vendor. Any non-resident small, women-owned, or minority-owned business must identify itself as such in writing, must submit that writing to the Purchasing Division with its bid, and must be properly certified under W. Va. CSR § 148-22-9 prior to contract award to receive the preferences made available to resident vendors. Preference for a non-resident small, women-owned, or minority owned business shall be applied in accordance with W. Va. CSR § 148-22-9.
- 12. ELECTRONIC FILE ACCESS RESTRICTIONS:** Vendor must ensure that its submission in wvOASIS can be accessed by the Agency staff immediately upon bid opening. The Agency will consider any file that cannot be immediately opened and/or viewed at the time of the bid opening (such as, encrypted files, password protected files, or incompatible files) to be blank or incomplete as context requires, and therefore unacceptable. A vendor will not be permitted to unencrypt files, remove password protections, or resubmit documents after bid opening if those documents are required with the bid.

GENERAL TERMS AND CONDITIONS:
(Agency Delegated Procurements Only)

1. **CONTRACTUAL AGREEMENT:** Issuance of a Award Document signed by the Agency and approved as to form by the Attorney General's office, if required, constitutes acceptance of this Contract made by and between the State of West Virginia and the Vendor. Vendor's signature on its bid signifies Vendor's agreement to be bound by and accept the terms and conditions contained in this Contract.

2. **DEFINITIONS:** As used in this Solicitation/Contract, the following terms shall have the meanings attributed to them below. Additional definitions may be found in the specifications included with this Solicitation/Contract.
 - 2.1. **"Agency" or "Agencies"** means the agency, board, commission, or other entity of the State of West Virginia that is identified on the first page of the Solicitation or any other public entity seeking to procure goods or services under this Contract.
 - 2.2. **"Contract"** means the binding agreement that is entered into between the State and the Vendor to provide the goods or services requested in the Solicitation.
 - 2.3. **"Director"** means the Director of the West Virginia Department of Administration, Purchasing Division.
 - 2.4. **"Purchasing Division"** means the West Virginia Department of Administration, Purchasing Division.
 - 2.5. **"Award Document"** means the document signed by the Agency and the Purchasing Division, and approved as to form by the Attorney General, that identifies the Vendor as the contract holder.
 - 2.6. **"Solicitation"** means the official notice of an opportunity to supply the State with goods or services.
 - 2.7. **"State"** means the State of West Virginia and/or any of its agencies, commissions, boards, etc. as context requires.
 - 2.8. **"Vendor" or "Vendors"** means any entity submitting a bid in response to the Solicitation, the entity that has been selected as the lowest responsible bidder, or the entity that has been awarded the Contract as context requires.

3. **CONTRACT TERM; RENEWAL; EXTENSION:** The term of this Contract shall be determined in accordance with the category that has been identified as applicable to this Contract below:

Term Contract

Initial Contract Term: This Contract becomes effective on _____ and extends for a period of one (1) year(s).

Renewal Term: This Contract may be renewed upon the mutual written consent of the Agency, and the Vendor. Any request for renewal should be submitted to the Agency thirty (30) days prior to the expiration date of the initial contract term or appropriate renewal term. A Contract renewal shall be in accordance with the terms and conditions of the original contract. Renewal of this Contract is limited to two (2) successive one (1) year periods or multiple renewal periods of less than one year, provided that the multiple renewal periods do not exceed twenty-four (24) months in total. Automatic renewal of this Contract is prohibited.

Delivery Order Limitations: In the event that this contract permits delivery orders, a delivery order may only be issued during the time this Contract is in effect. Any delivery order issued within one year of the expiration of this Contract shall be effective for one year from the date the delivery order is issued. No delivery order may be extended beyond one year after this Contract has expired.

Fixed Period Contract: This Contract becomes effective upon Vendor's receipt of the notice to proceed and must be completed within _____ days.

Fixed Period Contract with Renewals: This Contract becomes effective upon Vendor's receipt of the notice to proceed and part of the Contract more fully described in the attached specifications must be completed within _____ days. Upon completion, the vendor agrees that maintenance, monitoring, or warranty services will be provided for _____ successive one year periods or multiple periods of less than one year provided that the multiple renewal periods do not exceed _____ months in total.

One Time Purchase: The term of this Contract shall run from the issuance of the Award Document until all of the goods contracted for have been delivered, but in no event will this Contract extend for more than one fiscal year.

Other: See attached.

4. **NOTICE TO PROCEED:** Vendor shall begin performance of this Contract immediately upon receiving notice to proceed unless otherwise instructed by the Agency. Unless otherwise specified, the fully executed Award Document will be considered notice to proceed.

5. **QUANTITIES:** The quantities required under this Contract shall be determined in accordance with the category that has been identified as applicable to this Contract below.

- Open End Contract:** Quantities listed in this Solicitation are approximations only, based on estimates supplied by the Agency. It is understood and agreed that the Contract shall cover the quantities actually ordered for delivery during the term of the Contract, whether more or less than the quantities shown.
- Service:** The scope of the service to be provided will be more clearly defined in the specifications included herewith.
- Combined Service and Goods:** The scope of the service and deliverable goods to be provided will be more clearly defined in the specifications included herewith.
- One Time Purchase:** This Contract is for the purchase of a set quantity of goods that are identified in the specifications included herewith. Once those items have been delivered, no additional goods may be procured under this Contract without an appropriate change order approved by the Vendor, Agency, Purchasing Division, and Attorney General's office.
6. **PRICING:** The pricing set forth herein is firm for the life of the Contract, unless specified elsewhere within this Solicitation/Contract by the State. A Vendor's inclusion of price adjustment provisions in its bid, without an express authorization from the State in the Solicitation to do so, may result in bid disqualification.
7. **EMERGENCY PURCHASES:** The Purchasing Division Director may authorize the Agency to purchase goods or services in the open market that Vendor would otherwise provide under this Contract if those goods or services are for immediate or expedited delivery in an emergency. Emergencies shall include, but are not limited to, delays in transportation or an unanticipated increase in the volume of work. An emergency purchase in the open market, approved by the Purchasing Division Director, shall not constitute a breach of this Contract and shall not entitle the Vendor to any form of compensation or damages. This provision does not excuse the State from fulfilling its obligations under a One Time Purchase contract.
8. **REQUIRED DOCUMENTS:** All of the items checked below must be provided to the Agency by the Vendor as specified below.
- BID BOND:** All Vendors shall furnish a bid bond in the amount of five percent (5%) of the total amount of the bid protecting the State of West Virginia. The bid bond must be submitted with the bid.
- PERFORMANCE BOND:** The apparent successful Vendor shall provide a performance bond in the amount of _____. The performance bond must be received by the Purchasing Division prior to Contract award. On construction contracts, the performance bond must be 100% of the Contract value.
- LABOR/MATERIAL PAYMENT BOND:** The apparent successful Vendor shall provide a labor/material payment bond in the amount of 100% of the Contract value.

The labor/material payment bond must be delivered to the Purchasing Division prior to Contract award.

In lieu of the Bid Bond, Performance Bond, and Labor/Material Payment Bond, the Vendor may provide certified checks, cashier's checks, or irrevocable letters of credit. Any certified check, cashier's check, or irrevocable letter of credit provided in lieu of a bond must be of the same amount and delivered on the same schedule as the bond it replaces. A letter of credit submitted in lieu of a performance and labor/material payment bond will only be allowed for projects under \$100,000. Personal or business checks are not acceptable.

MAINTENANCE BOND: The apparent successful Vendor shall provide a two (2) year maintenance bond covering the roofing system. The maintenance bond must be issued and delivered to the Purchasing Division prior to Contract award.

INSURANCE: The apparent successful Vendor shall furnish proof of the following insurance prior to Contract award and shall list the state as a certificate holder:

Commercial General Liability Insurance: In the amount of _____ or more.

Builders Risk Insurance: In an amount equal to 100% of the amount of the Contract.

The apparent successful Vendor shall also furnish proof of any additional insurance requirements contained in the specifications prior to Contract award regardless of whether or not that insurance requirement is listed above.

LICENSE(S) / CERTIFICATIONS / PERMITS: In addition to anything required under the Section entitled Licensing, of the General Terms and Conditions, the apparent successful Vendor shall furnish proof of the following licenses, certifications, and/or permits prior to Contract award, in a form acceptable to the Agency.

-
-
-

The apparent successful Vendor shall also furnish proof of any additional licenses or certifications contained in the specifications prior to Contract award regardless of whether or not that requirement is listed above.

9. **WORKERS' COMPENSATION INSURANCE:** The apparent successful Vendor shall comply with laws relating to workers compensation, shall maintain workers' compensation insurance when required, and shall furnish proof of workers' compensation insurance upon request.
10. **LIQUIDATED DAMAGES:** Vendor shall pay liquidated damages in the amount of \$40 per Calendar Day _____ for (see Contract specification) _____. This clause shall in no way be considered exclusive and shall not limit the State or Agency's right to pursue any other available remedy.
11. **ACCEPTANCE/REJECTION:** The State may accept or reject any bid in whole, or in part. Vendor's signature on its bid signifies acceptance of the terms and conditions contained in the Solicitation and Vendor agrees to be bound by the terms of the Contract, as reflected in the Award Document, upon receipt.
12. **FUNDING:** This Contract shall continue for the term stated herein, contingent upon funds being appropriated by the Legislature or otherwise being made available. In the event funds are not appropriated or otherwise made available, this Contract becomes void and of no effect beginning on July 1 of the fiscal year for which funding has not been appropriated or otherwise made available.
13. **PAYMENT:** Payment in advance is prohibited under this Contract. Payment may only be made after the delivery and acceptance of goods or services. The Vendor shall submit invoices, in arrears.
14. **TAXES:** The Vendor shall pay any applicable sales, use, personal property or any other taxes arising out of this Contract and the transactions contemplated thereby. The State of West Virginia is exempt from federal and state taxes and will not pay or reimburse such taxes.
15. **CANCELLATION:** The State reserves the right to cancel this Contract immediately upon written notice to the vendor if the materials or workmanship supplied do not conform to the specifications contained in the Contract. The Purchasing Division Director may also cancel

any purchase or Contract upon 30 days written notice to the Vendor in accordance with West Virginia Code of State Rules § 148-1-7.16.2.

16. **TIME:** Time is of the essence with regard to all matters of time and performance in this Contract.
17. **APPLICABLE LAW:** This Contract is governed by and interpreted under West Virginia law without giving effect to its choice of law principles. Any information provided in specification manuals, or any other source, verbal or written, which contradicts or violates the West Virginia Constitution, West Virginia Code or West Virginia Code of State Rules is void and of no effect.
18. **COMPLIANCE:** Vendor shall comply with all applicable federal, state, and local laws, regulations and ordinances. By submitting a bid, Vendor acknowledges that it has reviewed, understands, and will comply with all applicable law.
19. **PREVAILING WAGE:** Vendor shall be responsible for ensuring compliance with prevailing wage requirements and determining when prevailing wage requirements are applicable.
20. **ARBITRATION:** Any references made to arbitration contained in this Contract, Vendor's bid, or in any American Institute of Architects documents pertaining to this Contract are hereby deleted, void, and of no effect.
21. **MODIFICATIONS:** This writing is the parties' final expression of intent. Notwithstanding anything contained in this Contract to the contrary, no modification of this Contract shall be binding without mutual written consent of the Agency, and the Vendor.
22. **WAIVER:** The failure of either party to insist upon a strict performance of any of the terms or provision of this Contract, or to exercise any option, right, or remedy herein contained, shall not be construed as a waiver or a relinquishment for the future of such term, provision, option, right, or remedy, but the same shall continue in full force and effect. Any waiver must be expressly stated in writing and signed by the waiving party.
23. **SUBSEQUENT FORMS:** The terms and conditions contained in this Contract shall supersede any and all subsequent terms and conditions which may appear on any form documents submitted by Vendor to the Agency or Purchasing Division such as price lists, order forms, invoices, sales agreements, or maintenance agreements, and includes internet websites or other electronic documents. Acceptance or use of Vendor's forms does not constitute acceptance of the terms and conditions contained thereon.
24. **ASSIGNMENT:** Neither this Contract nor any monies due, or to become due hereunder, may be assigned by the Vendor without the express written consent of the Agency and any other government agency or office that may be required to approve such assignments.

- 25. WARRANTY:** The Vendor expressly warrants that the goods and/or services covered by this Contract will: (a) conform to the specifications, drawings, samples, or other description furnished or specified by the Agency; (b) be merchantable and fit for the purpose intended; and (c) be free from defect in material and workmanship.
- 26. STATE EMPLOYEES:** State employees are not permitted to utilize this Contract for personal use and the Vendor is prohibited from permitting or facilitating the same.
- 27. BANKRUPTCY:** In the event the Vendor files for bankruptcy protection, the State of West Virginia may deem this Contract null and void, and terminate this Contract without notice.
- 28. CONFIDENTIALITY:** The Vendor agrees that it will not disclose to anyone, directly or indirectly, any such personally identifiable information or other confidential information gained from the Agency, unless the individual who is the subject of the information consents to the disclosure in writing or the disclosure is made pursuant to the Agency's policies, procedures, and rules. Vendor further agrees to comply with the Confidentiality Policies and Information Security Accountability Requirements, set forth in <http://www.state.wv.us/admin/purchase/privacy/default.html>.
- 29. DISCLOSURE:** Vendor's response to the Solicitation and the resulting Contract are considered public documents and will be disclosed to the public in accordance with the laws, rules, and policies governing the West Virginia Purchasing Division. Those laws include, but are not limited to, the Freedom of Information Act found in West Virginia Code §§ 29B-1-1 et seq. and the competitive bidding laws found West Virginia Code §§ 5A-3-1 et seq., 5-22-1 et seq., and 5G-1-1 et seq.

If a Vendor considers any part of its bid to be exempt from public disclosure, Vendor must so indicate by specifically identifying the exempt information, identifying the exemption that applies, providing a detailed justification for the exemption, segregating the exempt information from the general bid information, and submitting the exempt information as part of its bid but in a segregated and clearly identifiable format. Failure to comply with the foregoing requirements will result in public disclosure of the Vendor's bid without further notice. A Vendor's act of marking all or nearly all of its bid as exempt is not sufficient to avoid disclosure and WILL NOT BE HONORED. Vendor's act of marking a bid or any part thereof as "confidential" or "proprietary" is not sufficient to avoid disclosure and WILL NOT BE HONORED. A legend or other statement indicating that all or substantially all of the bid is exempt from disclosure is not sufficient to avoid disclosure and WILL NOT BE HONORED. Additionally, pricing or cost information will not be considered exempt from disclosure and requests to withhold publication of pricing or cost information WILL NOT BE HONORED.

Vendor will be required to defend any claimed exemption for nondisclosure in the event of an administrative or judicial challenge to the State's nondisclosure. Vendor must indemnify the State for any costs incurred related to any exemptions claimed by Vendor. Any questions regarding the applicability of the various public records laws should be addressed to your own legal counsel prior to bid submission.

30. LICENSING: In accordance with West Virginia Code of State Rules §148-1-6.1.7, Vendor must be licensed and in good standing in accordance with any and all state and local laws and requirements by any state or local agency of West Virginia, including, but not limited to, the West Virginia Secretary of State's Office, the West Virginia Tax Department, West Virginia Insurance Commission, or any other state agency or political subdivision. Upon request, the Vendor must provide all necessary releases to obtain information to enable the Agency to verify that the Vendor is licensed and in good standing with the above entities.

31. ANTITRUST: In submitting a bid to, signing a contract with, or accepting an Award Document from any agency of the State of West Virginia, the Vendor agrees to convey, sell, assign, or transfer to the State of West Virginia all rights, title, and interest in and to all causes of action it may now or hereafter acquire under the antitrust laws of the United States and the State of West Virginia for price fixing and/or unreasonable restraints of trade relating to the particular commodities or services purchased or acquired by the State of West Virginia. Such assignment shall be made and become effective at the time the purchasing agency tenders the initial payment to Vendor.

32. VENDOR CERTIFICATIONS: By signing its bid or entering into this Contract, Vendor certifies (1) that its bid or offer was made without prior understanding, agreement, or connection with any corporation, firm, limited liability company, partnership, person or entity submitting a bid or offer for the same material, supplies, equipment or services; (2) that its bid or offer is in all respects fair and without collusion or fraud; (3) that this Contract is accepted or entered into without any prior understanding, agreement, or connection to any other entity that could be considered a violation of law; and (4) that it has reviewed this Solicitation in its entirety; understands the requirements, terms and conditions, and other information contained herein. Vendor's signature on its bid or offer also affirms that neither it nor its representatives have any interest, nor shall acquire any interest, direct or indirect, which would compromise the performance of its services hereunder. Any such interests shall be promptly presented in detail to the Agency. The individual signing this bid or offer on behalf of Vendor certifies that he or she is authorized by the Vendor to execute this bid or offer or any documents related thereto on Vendor's behalf; that he or she is authorized to bind the Vendor in a contractual relationship; and that, to the best of his or her knowledge, the Vendor has properly registered with any State agency that may require registration.

33. PURCHASING CARD ACCEPTANCE: The State of West Virginia currently utilizes a Purchasing Card program, administered under contract by a banking institution, to process payment for goods and services. The Vendor must accept the State of West Virginia's Purchasing Card for payment of all orders under this Contract unless the box below is checked.

Vendor is not required to accept the State of West Virginia's Purchasing Card as payment for all goods and services.

34. VENDOR RELATIONSHIP: The relationship of the Vendor to the State shall be that of an independent contractor and no principal-agent relationship or employer-employee

relationship is contemplated or created by this Contract. The Vendor as an independent contractor is solely liable for the acts and omissions of its employees and agents. Vendor shall be responsible for selecting, supervising, and compensating any and all individuals employed pursuant to the terms of this Solicitation and resulting contract. Neither the Vendor, nor any employees or subcontractors of the Vendor, shall be deemed to be employees of the State for any purpose whatsoever. Vendor shall be exclusively responsible for payment of employees and contractors for all wages and salaries, taxes, withholding payments, penalties, fees, fringe benefits, professional liability insurance premiums, contributions to insurance and pension, or other deferred compensation plans, including but not limited to, Workers' Compensation and Social Security obligations, licensing fees, etc. and the filing of all necessary documents, forms, and returns pertinent to all of the foregoing. Vendor shall hold harmless the State, and shall provide the State and Agency with a defense against any and all claims including, but not limited to, the foregoing payments, withholdings, contributions, taxes, Social Security taxes, and employer income tax returns.

35. INDEMNIFICATION: The Vendor agrees to indemnify, defend, and hold harmless the State and the Agency, their officers, and employees from and against: (1) Any claims or losses for services rendered by any subcontractor, person, or firm performing or supplying services, materials, or supplies in connection with the performance of the Contract; (2) Any claims or losses resulting to any person or entity injured or damaged by the Vendor, its officers, employees, or subcontractors by the publication, translation, reproduction, delivery, performance, use, or disposition of any data used under the Contract in a manner not authorized by the Contract, or by Federal or State statutes or regulations; and (3) Any failure of the Vendor, its officers, employees, or subcontractors to observe State and Federal laws including, but not limited to, labor and wage and hour laws.

36. PURCHASING AFFIDAVIT: In accordance with West Virginia Code § 5A-3-10a, all Vendors are required to sign, notarize, and submit the Purchasing Affidavit stating that neither the Vendor nor a related party owe a debt to the State in excess of \$1,000. The affidavit must be submitted prior to award, but should be submitted with the Vendor's bid. A copy of the Purchasing Affidavit is included herewith.

37. CONFLICT OF INTEREST: Vendor, its officers or members or employees, shall not presently have or acquire an interest, direct or indirect, which would conflict with or compromise the performance of its obligations hereunder. Vendor shall periodically inquire of its officers, members and employees to ensure that a conflict of interest does not arise. Any conflict of interest discovered shall be promptly presented in detail to the Agency.

38. REPORTS: Vendor shall provide the Agency and/or the Purchasing Division with the following reports identified by a checked box below:

- Such reports as the Agency and/or the Purchasing Division may request. Requested reports may include, but are not limited to, quantities purchased, agencies utilizing the contract, total contract expenditures by agency, etc.

- Quarterly reports detailing the total quantity of purchases in units and dollars, along with a listing of purchases by agency. Quarterly reports should be delivered to the Purchasing Division via email at purchasing.requisitions@wv.gov.

39. BACKGROUND CHECK: In accordance with W. Va. Code § 15-2D-3, the Director of the Division of Protective Services shall require any service provider whose employees are regularly employed on the grounds or in the buildings of the Capitol complex or who have access to sensitive or critical information to submit to a fingerprint-based state and federal background inquiry through the state repository. The service provider is responsible for any costs associated with the fingerprint-based state and federal background inquiry.

After the contract for such services has been approved, but before any such employees are permitted to be on the grounds or in the buildings of the Capitol complex or have access to sensitive or critical information, the service provider shall submit a list of all persons who will be physically present and working at the Capitol complex to the Director of the Division of Protective Services for purposes of verifying compliance with this provision.

The State reserves the right to prohibit a service provider's employees from accessing sensitive or critical information or to be present at the Capitol complex based upon results addressed from a criminal background check.

Service providers should contact the West Virginia Division of Protective Services by phone at (304) 558-9911 for more information.

40. PREFERENCE FOR USE OF DOMESTIC STEEL PRODUCTS: Except when authorized by the Director of the Purchasing Division pursuant to W. Va. Code § 5A-3-56, no contractor may use or supply steel products for a State Contract Project other than those steel products made in the United States. A contractor who uses steel products in violation of this section may be subject to civil penalties pursuant to W. Va. Code § 5A-3-56. As used in this section:

- a. "State Contract Project" means any erection or construction of, or any addition to, alteration of or other improvement to any building or structure, including, but not limited to, roads or highways, or the installation of any heating or cooling or ventilating plants or other equipment, or the supply of and materials for such projects, pursuant to a contract with the State of West Virginia for which bids were solicited on or after June 6, 2001.
- b. "Steel Products" means products rolled, formed, shaped, drawn, extruded, forged, cast, fabricated or otherwise similarly processed, or processed by a combination of two or more or such operations, from steel made by the open heath, basic oxygen, electric furnace, Bessemer or other steel making process. The Purchasing Division Director may, in writing, authorize the use of foreign steel products if:
- c. The cost for each contract item used does not exceed one tenth of one percent (.1%) of the total contract cost or two thousand five hundred dollars (\$2,500.00), whichever is greater.

For the purposes of this section, the cost is the value of the steel product as delivered to the project; or

- d. The Director of the Purchasing Division determines that specified steel materials are not produced in the United States in sufficient quantity or otherwise are not reasonably available to meet contract requirements.

41. PREFERENCE FOR USE OF DOMESTIC ALUMINUM, GLASS, AND STEEL: In Accordance with W. Va. Code § 5-19-1 et seq., and W. Va. CSR § 148-10-1 et seq., for every contract or subcontract, subject to the limitations contained herein, for the construction, reconstruction, alteration, repair, improvement or maintenance of public works or for the purchase of any item of machinery or equipment to be used at sites of public works, only domestic aluminum, glass or steel products shall be supplied unless the spending officer determines, in writing, after the receipt of offers or bids, (1) that the cost of domestic aluminum, glass or steel products is unreasonable or inconsistent with the public interest of the State of West Virginia, (2) that domestic aluminum, glass or steel products are not produced in sufficient quantities to meet the contract requirements, or (3) the available domestic aluminum, glass, or steel do not meet the contract specifications. This provision only applies to public works contracts awarded in an amount more than fifty thousand dollars (\$50,000) or public works contracts that require more than ten thousand pounds of steel products.

The cost of domestic aluminum, glass, or steel products may be unreasonable if the cost is more than twenty percent (20%) of the bid or offered price for foreign made aluminum, glass, or steel products. If the domestic aluminum, glass or steel products to be supplied or produced in a "substantial labor surplus area", as defined by the United States Department of Labor, the cost of domestic aluminum, glass, or steel products may be unreasonable if the cost is more than thirty percent (30%) of the bid or offered price for foreign made aluminum, glass, or steel products.

This preference shall be applied to an item of machinery or equipment, as indicated above, when the item is a single unit of equipment or machinery manufactured primarily of aluminum, glass or steel, is part of a public works contract and has the sole purpose or of being a permanent part of a single public works project. This provision does not apply to equipment or machinery purchased by a spending unit for use by that spending unit and not as part of a single public works project.

All bids and offers including domestic aluminum, glass or steel products that exceed bid or offer prices including foreign aluminum, glass or steel products after application of the preferences provided in this provision may be reduced to a price equal to or lower than the lowest bid or offer price for foreign aluminum, glass or steel products plus the applicable preference. If the reduced bid or offer prices are made in writing and supersede the prior bid or offer prices, all bids or offers, including the reduced bid or offer prices, will be reevaluated in accordance with this rule.

ADDITIONAL TERMS AND CONDITIONS (Construction Contracts Only)

1. **CONTRACTOR'S LICENSE:** West Virginia Code § 21-11-2 requires that all persons desiring to perform contracting work in this state be licensed. The West Virginia Contractors Licensing Board is empowered to issue the contractor's license. Applications for a contractor's license may be made by contacting the West Virginia Division of Labor. West Virginia Code § 21-11-11 requires any prospective Vendor to include the contractor's license number on its bid. Failure to include a contractor's license number on the bid shall result in Vendor's bid being disqualified. Vendors should include a contractor's license number in the space provided below.

Contractor's Name: New Enterprise Stone & Lime Co., Inc.

Contractor's License No. 24515

The apparent successful Vendor must furnish a copy of its contractor's license prior to the issuance of a Award Document.

2. **DRUG-FREE WORKPLACE AFFIDAVIT:** W. Va. Code § 21-1D-5 provides that any solicitation for a public improvement contract requires each Vendor that submits a bid for the work to submit at the same time an affidavit that the Vendor has a written plan for a drug-free workplace policy. To comply with this law, Vendor must either complete the enclosed drug-free workplace affidavit and submit the same with its bid or complete a similar affidavit that fulfills all of the requirements of the applicable code. Failure to submit the signed and notarized drug-free workplace affidavit or a similar affidavit that fully complies with the requirements of the applicable code, with the bid shall result in disqualification of Vendor's bid. Pursuant to W. Va. Code 21-1D-2(b) and (k), this provision does not apply to public improvement contracts the value of which is \$100,000 or less or temporary or emergency repairs.

2.1. **DRUG-FREE WORKPLACE POLICY:** Pursuant to W. Va. Code § 21-1D-4, Vendor and its subcontractors must implement and maintain a written drug-free workplace policy that complies with said article. The awarding public authority shall cancel this contract if: (1) Vendor fails to implement and maintain a written drug-free workplace policy described in the preceding paragraph, (2) Vendor fails to provide information regarding implementation of its drug-free workplace policy at the request of the public authority; or (3) Vendor provides to the public authority false information regarding the contractor's drug-free workplace policy. Pursuant to W. Va. Code 21-1D-2(b) and (k), this provision does not apply to public improvement contracts the value of which is \$100,000 or less or temporary or emergency repairs.

3. **DRUG FREE WORKPLACE REPORT:** Pursuant to W. Va. Code § 21-1D-7b, no less than once per year, or upon completion of the project, every contractor shall provide a certified report to the public authority which let the contract. For contracts over \$25,000, the

public authority shall be the West Virginia Purchasing Division. For contracts of \$25,000 or less, the public authority shall be the agency issuing the contract. The report shall include:

- (1) Information to show that the education and training service to the requirements of West Virginia Code § 21-1D-5 was provided;
- (2) The name of the laboratory certified by the United States Department of Health and Human Services or its successor that performs the drug tests;
- (3) The average number of employees in connection with the construction on the public improvement;
- (4) Drug test results for the following categories including the number of positive tests and the number of negative tests: (A) Pre-employment and new hires; (B) Reasonable suspicion; (C) Post-accident; and (D) Random.

Vendor should utilize the attached Certified Drug Free Workplace Report Coversheet when submitting the report required hereunder. Pursuant to W. Va. Code 21-1D-2(b) and (k), this provision does not apply to public improvement contracts the value of which is \$100,000 or less or temporary or emergency repairs.

4. **AIA DOCUMENTS:** All construction contracts that will be completed in conjunction with architectural services procured under Chapter 5G of the West Virginia Code will be governed by the AIA A101-2007 and A201-2007 or the A107-2007 documents, as amended by the Supplementary Conditions for the State of West Virginia, in addition to the terms and conditions contained herein.
5. **SUBCONTRACTOR LIST SUBMISSION:** In accordance with W. Va. Code § 5-22-1, The apparent low bidder on a contract for the construction, alteration, decoration, painting or improvement of a new or existing building or structure valued at more than \$250,000.00 shall submit a list of all subcontractors who will perform more than \$25,000.00 of work on the project including labor and materials. This provision shall not apply to any other construction projects, such as highway, mine reclamation, water or sewer projects. Additionally, if no subcontractors who will perform more than \$25,000.00 of work are to be used to complete the project, it will be noted on the subcontractor list.
 - a. Required Information. The subcontractor list shall contain the following information:
 - i. Bidder's name
 - ii. Name of each subcontractor
 - iii. License numbers as required by W. Va. Code § 21-11-1 et. seq.
 - iv. Notation that no subcontractor will be used to perform more than \$25,000.00 of work, when applicable
 - b. Submission. The completed subcontractor list shall be provided to the Purchasing Division within one business day of the opening of bids for review. Failure to submit the subcontractor

list within one business day after the deadline for submitting bids shall result in disqualification of the bid.

c. Substitution of Subcontractor. Written approval must be obtained from the State Spending Unit before any subcontractor substitution is permitted. Substitutions are not permitted unless:

- i. The subcontractor listed in the original bid has filed for bankruptcy;
- ii. The subcontractor in the original bid has been debarred or suspended; or
- iii. The contractor certifies in writing that the subcontractor listed in the original bill fails, is unable, or refuses to perform his subcontract.

6. **GREEN BUILDINGS MINIMUM ENERGY STANDARDS:** In accordance with § 22-29-4, all new building construction projects of public agencies that have not entered the schematic design phase prior to July 1, 2012, or any building construction project receiving state grant funds and appropriations, including public schools, that have not entered the schematic design phase prior to July 1, 2012, shall be designed and constructed complying with the ICC International Energy Conservation Code, adopted by the State Fire Commission, and the ANSI/ASHRAE/IESNA Standard 90.1-2007: Provided, That if any construction project has a commitment of federal funds to pay for a portion of such project, this provision shall only apply to the extent such standards are consistent with the federal standards.

**ADDITIONAL TERMS AND CONDITIONS (Architectural and Engineering Contracts
Only)**

1. **PLAN AND DRAWING DISTRIBUTION:** All plans and drawings must be completed and available for distribution at least five business days prior to a scheduled pre-bid meeting for the construction or other work related to the plans and drawings.
2. **PROJECT ADDENDA REQUIREMENTS:** The Architect/Engineer and/or Agency shall be required to abide by the following schedule in issuing construction project addenda. The Architect/Engineer shall prepare any addendum materials for which it is responsible, and a list of all vendors that have obtained drawings and specifications for the project. The Architect/Engineer shall then send a copy of the addendum materials and the list of vendors to the State Agency for which the contract is issued to allow the Agency to make any necessary modifications. The addendum and list shall then be forwarded to the Purchasing Division buyer by the Agency. The Purchasing Division buyer shall send the addendum to all interested vendors and, if necessary, extend the bid opening date. Any addendum should be received by the Purchasing Division at least fourteen (14) days prior to the bid opening date.
3. **PRE-BID MEETING RESPONSIBILITIES:** The Architect/Engineer shall be available to attend any pre-bid meeting for the construction or other work resulting from the plans, drawings, or specifications prepared by the Architect/Engineer.
4. **AIA DOCUMENTS:** Contracts for architectural and engineering services will be governed by the AIA document B101-2007, as amended by the Supplementary Conditions for the State of West Virginia, in addition to the terms and conditions contained herein when procured under Chapter 5G of the West Virginia Code.
5. **GREEN BUILDINGS MINIMUM ENERGY STANDARDS:** In accordance with West Virginia Code § 22-29-4, all new building construction projects of public agencies that have not entered the schematic design phase prior to July 1, 2012, or any building construction project receiving state grant funds and appropriations, including public schools, that have not entered the schematic design phase prior to July 1, 2012, shall be designed and constructed complying with the ICC International Energy Conservation Code, adopted by the State Fire Commission, and the ANSI/ASHRAE/IESNA Standard 90.1-2007: Provided, That if any construction project has a commitment of federal funds to pay for a portion of such project, this provision shall only apply to the extent such standards are consistent with the federal standards.

CERTIFICATION AND SIGNATURE PAGE

By signing below, or submitting documentation through wvOASIS, I certify that I have reviewed this Solicitation in its entirety; understand the requirements, terms and conditions, and other information contained herein; that I am submitting this bid, offer or proposal for review and consideration; that I am authorized by the vendor to execute and submit this bid, offer, or proposal, or any documents related thereto on vendor's behalf; that I am authorized to bind the vendor in a contractual relationship; and that to the best of my knowledge, the vendor has properly registered with any State agency that may require registration.

Protection Services Inc.

(Company)

S. Miceli - Douglas Miceli, Field Services Manager

(Authorized Signature) (Representative Name, Title)

717-236-9307 / FAX 717-236-1281 / Date: 11/2/15

(Phone Number) (Fax Number) (Date)

ADDENDUM ACKNOWLEDGEMENT FORM
SOLICITATION NO.:

Instructions: Please acknowledge receipt of all addenda issued with this solicitation by completing this addendum acknowledgment form. Check the box next to each addendum received and sign below. Failure to acknowledge addenda may result in bid disqualification.

Acknowledgment: I hereby acknowledge receipt of the following addenda and have made the necessary revisions to my proposal, plans and/or specification, etc.

Addendum Numbers Received:
(Check the box next to each addendum received)

- | | |
|---|--|
| <input type="checkbox"/> Addendum No. 1 | <input type="checkbox"/> Addendum No. 6 |
| <input type="checkbox"/> Addendum No. 2 | <input type="checkbox"/> Addendum No. 7 |
| <input type="checkbox"/> Addendum No. 3 | <input type="checkbox"/> Addendum No. 8 |
| <input type="checkbox"/> Addendum No. 4 | <input type="checkbox"/> Addendum No. 9 |
| <input type="checkbox"/> Addendum No. 5 | <input type="checkbox"/> Addendum No. 10 |

I understand that failure to confirm the receipt of addenda may be cause for rejection of this bid. I further understand that any verbal representation made or assumed to be made during any oral discussion held between Vendor's representatives and any state personnel is not binding. Only the information issued in writing and added to the specifications by an official addendum is binding.

Protection Services Inc.
Company

[Signature]
Authorized Signature

~~11/2~~ 11/2/15
Date

NOTE: This addendum acknowledgment should be submitted with the bid to expedite document processing.

REQUEST FOR QUOTATION
Work Area Protection Impact Attenuator Parts

SPECIFICATIONS

1. **PURPOSE AND SCOPE:** The West Virginia Purchasing Division is soliciting bids on behalf of the WVDOH to establish an open-end contract for Work Area Protection impact attenuator parts.

2. **DEFINITIONS:** The terms listed below shall have the meanings assigned to them below. Additional definitions can be found in section 2 of the General Terms and Conditions.
 - 2.1 **“Contract Item”** or **“Contract Items”** means the list of items identified in Section 3.1 below and on the Pricing Pages.

 - 2.2 **“Pricing Pages”** means the schedule of prices, estimated order quantity, and totals contained in wvOASIS or attached hereto as Exhibit A, and used to evaluate the Solicitation responses.

 - 2.3 **“Solicitation”** means the official notice of an opportunity to supply the State with goods or services that is published by the Purchasing Division.

 - 2.4 **“Work Area Protection”** means Work Area Protection Corporation of 2500 Production Drive, St.Charles, IL

 - 2.5 **“WVDOH”** means the West Virginia Division of Highways.

 - 2.6 **“FHWA”** means Federal Highway Administration

 - 2.7 **“NCHRP-350”** means National Cooperative Highway Research Program Report 350, a copy of which may be obtained at the following site:

http://onlinepubs.trb.org/onlinepubs/nchrp/nchrp_rpt_350-a.pdf

 - 2.8 **“NHS”** National Highway System

 - 2.9 **“owner”**, as used in Section 2.10 & 2.11 below, shall mean the owner of the rights to the device(s) specified in this Contract and the rights to devices for which the parts being supplied as part of this Contract are intended to be used with.

 - 2.10 **“equal”**, as used in Section 3.1.1.2, means that the supplied parts can be substituted for the parts specified in the Pricing Pages with no modifications, the parts are indistinguishable from the parts manufactured by the owner, the parts will perform and function the same as the parts manufactured by the owner, the manufacturing and supplying of the parts do not violate any rights or patents of the owner, and the

REQUEST FOR QUOTATION
Work Area Protection Impact Attenuator Parts

use of such parts will have no effect on the devices eligibility to be used on the NHS. If a Vendor proposes to supply parts not manufactured by the owner, the Vendor, parts manufacturer, and owner shall each attest in writing to each of the previously specified requirements for the parts to be considered “equal”. In addition, the Vendor shall provide an acknowledgement letter from the FHWA stating that the use of replacement parts from the specified manufacturer will not affect the eligibility of the devices to be used on the NHS.

- 2.11 “equal”, as used in Sections 3.1.2.2, means that the supplied devices can be substituted for the devices specified in the Pricing Pages with no modifications to the devices or the existing base & transition anchors originally installed for the devices specified, the devices can be repaired using the parts supplied under this Contract intended to be used for repairing the devices specified, the devices have been acknowledged by the FHWA as meeting the Test Level 2 or 3 (as applicable) requirements of NCHRP-350, and the manufacturing and supplying of the devices do not violate any rights or patents of the owner. If a Vendor proposes to supply devices other than those specified, the Vendor & device manufacturer shall each attest in writing to each of the previously specified requirements for the devices to be considered “equal”. In addition, the Vendor shall supply documentation to support their claim that devices have been acknowledged by the FHWA as meeting the Test Level 2 or 3 (as applicable) requirements of NCHRP-350 (full NCHRP-350 test report for the devices and FHWA acknowledgement letter).

3. GENERAL REQUIREMENTS:

- 3.1 Contract Items and Mandatory Requirements:** Vendor shall provide Agency with the Contract Items listed below on an open-end and continuing basis. Contract Items must meet or exceed the mandatory requirements as shown below.

3.1.1 Work Area Protection SCI Smart Cushion Impact Attenuator Replacement Parts

- 3.1.1.1** Items 1-32 as shown on Exhibit A, Pricing Sheets, shall be replacement parts for Work Area Protection SCI Smart Cushion impact attenuators
- 3.1.1.2** Items 1-28 shall be original replacement parts manufactured by Work Area Protection, or equal.
- 3.1.1.3** Manufacturer product drawings of various components, numbered to correlate with the sheet numbers referenced

REQUEST FOR QUOTATION
Work Area Protection Impact Attenuator Parts

in the "Part Detail Sheet(s)" column in Exhibit A, are attached hereto as Exhibit B.

3.1.2 Work Area Protection Complete SCI Smart Cushion Impact Attenuators

3.1.2.1 Items 33-34 as shown on Exhibit A, Pricing Sheets, shall be various length complete Work Area Protection Complete SCI Smart Cushion Impact Attenuators with installation components as described. Items 33-34 may only be ordered directly by the WVDOH Traffic Engineering Division.

3.1.2.2 Items 33-34 shall be original complete units manufactured by Work Area Protection, or equal.

4. CONTRACT AWARD:

4.1 Contract Award: The Contract is intended to provide Agencies with a purchase price on all Contract Items. The Contract shall be awarded to the Vendor that provides the Contract Items meeting the required specifications for the lowest overall total cost as shown on the Pricing Pages.

4.2 Pricing Pages: Vendor should complete the Pricing Pages by providing a unit price for all items listed. Vendor should complete the Pricing Pages in their entirety as failure to do so may result in Vendor's bids being disqualified.

The Pricing Pages contain a list of the Contract Items and estimated purchase volume. The estimated purchase volume for each item represents the approximate volume of anticipated purchases only. No future use of the Contract or any individual item is guaranteed or implied.

Vendor should electronically enter the information into the Pricing Pages through wvOASIS, if available, or as an electronic document. In most cases, the Vendor can request an electronic copy of the Pricing Pages for bid purposes by sending an email request to the following address: Crystal.G.Rink@wv.gov.

5. ORDERING AND PAYMENT:

5.1 Ordering: Vendor shall accept orders through wvOASIS, regular mail, facsimile, e-mail, or any other written form of communication. Vendor may, but is not required to, accept on-line orders through a secure internet ordering portal/website.

REQUEST FOR QUOTATION
Work Area Protection Impact Attenuator Parts

If Vendor has the ability to accept on-line orders, it should include in its response a brief description of how Agencies may utilize the on-line ordering system. Vendor shall ensure that its on-line ordering system is properly secured prior to processing Agency orders on-line.

5.2 Payment: Vendor shall accept payment in accordance with the payment procedures of the State of West Virginia.

6. DELIVERY AND RETURN:

6.1 Delivery Time: Vendor shall deliver standard orders within twenty one (21) Working Days after orders are received. Vendor shall deliver emergency orders within seven (7) Working Days after orders are received. Vendor shall ship all orders in accordance with the above schedule and shall not hold orders until a minimum delivery quantity is met.

6.2 Late Delivery: The Agency placing the order under this Contract must be notified in writing if orders will be delayed for any reason. Any delay in delivery that could cause harm to an Agency will be grounds for cancellation of the delayed order, and/or obtaining the items ordered from a third party.

Any Agency seeking to obtain items from a third party under this provision must first obtain approval of the Purchasing Division.

Regardless of whether or not the Vendor provides written notification of an order delay, if the Vendor is unable to deliver in full within twenty-one (21) Working Days after receipt of the order, the Vendor shall be subject to a daily (per Calendar Day) penalty at the purchasing Agency's discretion for each Calendar Day beyond the delivery deadline date until the order is received in full. This penalty shall be assessed by subtracting the penalty from the original total value of the Release Order, and shall be in the amount specified in Section 10 of the General Terms and Conditions document included as part of this Contract.

The Vendor shall not be subject to the above described penalty for non-delivery of items with seven (7) Working Days on emergency orders. The Vendor shall be subject to the above described penalty only when the delivery time of such items exceeds twenty-one (21) Working Days.

6.3 Delivery Payment/Risk of Loss: Standard order delivery shall be F.O.B. destination to the Agency's location. Vendor shall include the cost of standard order delivery charges in its bid pricing/discount and is not permitted to charge the Agency separately for such delivery. The Agency will pay additional delivery costs incurred on all emergency orders provided that Vendor invoices those delivery costs

REQUEST FOR QUOTATION
Work Area Protection Impact Attenuator Parts

as a separate charge with the original freight bill attached to the invoice. No markup shall be permitted for these additional charges. On any such orders, the Vendor may only invoice for additional freight charges incurred for items that are delivered within the specified (7) Working Days.

- 6.4 Return of Unacceptable Items:** If the Agency deems the Contract Items to be unacceptable, the Contract Items shall be returned to Vendor at Vendor's expense and with no restocking charge. Vendor shall either make arrangements for the return within five (5) days of being notified that items are unacceptable, or permit the Agency to arrange for the return and reimburse Agency for delivery expenses. If the original packaging cannot be utilized for the return, Vendor will supply the Agency with appropriate return packaging upon request. All returns of unacceptable items shall be F.O.B. the Agency's location. The returned product shall either be replaced, or the Agency shall receive a full credit or refund for the purchase price, at the Agency's discretion. The provisions of Section 6.2 shall apply until the entire Release Order is completed correctly and in full.
- 6.5 Return Due to Agency Error:** Items ordered in error by the Agency will be returned for credit within 30 days of receipt, F.O.B. Vendor's location. Vendor shall not charge a restocking fee if returned products are in a resalable condition. Items shall be deemed to be in a resalable condition if they are unused and in the original packaging. Any restocking fee for items not in a resalable condition shall be the lower of the Vendor's customary restocking fee or 5% of the total invoiced value of the returned items.
- 6.6 Packaging:** All large components shall be shipped adequately secured on pallets for ease in unloading. Large components shall be easily identifiable or the packaging shall be labeled indicating the contained parts. All accessory hardware and relatively small components shall be appropriately packaged and labeled.

7. VENDOR DEFAULT:

7.1 The following shall be considered a vendor default under this Contract.

- 7.1.1 Failure to provide Contract Items in accordance with the requirements contained herein.
- 7.1.2 Failure to comply with other specifications and requirements contained herein.
- 7.1.3 Failure to comply with any laws, rules, and ordinances applicable to the Contract Services provided under this Contract.

REQUEST FOR QUOTATION
Work Area Protection Impact Attenuator Parts

7.1.4 Failure to remedy deficient performance upon request.

7.2 The following remedies shall be available to Agency upon default.

7.2.1 Immediate cancellation of the Contract.

7.2.2 Immediate cancellation of one or more release orders issued under this Contract.

7.2.3 Any other remedies available in law or equity.

8. MISCELLANEOUS:

8.1 No Substitutions: Vendor shall supply only Contract Items submitted in response to the Solicitation unless a contract modification is approved in accordance with the provisions contained in this Contract.

8.2 Vendor Supply: Vendor must carry sufficient inventory of the Contract Items being offered to fulfill its obligations under this Contract. By signing its bid, Vendor certifies that it can supply the Contract Items contained in its bid response.

8.3 Reports: Vendor shall provide quarterly reports and annual summaries to the Agency showing the Agency's items purchased, quantities of items purchased, and total dollar value of the items purchased. Vendor shall also provide reports, upon request, showing the items purchased during the term of this Contract, the quantity purchased for each of those items, and the total value of purchases for each of those items. Failure to supply such reports may be grounds for cancellation of this Contract.

8.4 Contract Manager: During its performance of this Contract, Vendor must designate and maintain a primary contract manager responsible for overseeing Vendor's responsibilities under this Contract. The Contract manager must be available during normal business hours to address any customer service or other issues related to this Contract. Vendor should list its Contract manager and his or her contact information below.

Contract Manager: Denny Dawson
Telephone Number: 301-722-0282
Fax Number: 301-722-5455
Email Address: ddawson@protectionservices.com

EXHIBIT A - PRICING SHEETS

ITEM NUMBER	ESTIMATED QUANTITY	DESCRIPTION	PART DETAIL SHEET(S)	UNIT COST	EXTENDED TOTAL AMOUNT (QTY x UNIT COST)	(DOH USE ONLY) INVENTORY SUBCODE
		Work Area Protection/SCI Products Smart Cushion Attenuators				
		Shear Bolts				
1	1	Shear Bolt	NA	1.08	1.08	311100
		Side (fender) panels				
2	1	Front sled side panel (to include keepers and any other required hardware for attachment)	63/64	405	405	312100
3	1	Intermediary side panel (to include keepers and any other required hardware for attachment) DO NOT USE FOR SLED OR LAST BAY	63/64	194	194	312150
4	1	Rear bay side panel (to include keepers and any other required hardware for attachment)	63/64	171	171	312200
		Mobile Frames (Diaphragms)				
5	1	Mobile Frame #1 (1 st frame for TL-3 unit). To include side guides and any required hardware DO NOT USE IN TL-2 UNIT	63/64	375	375	NA
6	1	Mobile Frame #2 (2 nd frame for TL-3 unit). To include side guides and any required hardware DO NOT USE IN TL-2 UNIT	63/64	375	375	NA
7	1	Mobile Frame #3 (3 rd frame for TL-3 unit) To include side guides and any required hardware DO NOT USE IN TL-2 UNIT	63/64	375	375	NA
8	1	Mobile Frame #4 (4 th frame for TL-3 unit / 1 st frame for TL-2 unit) To include side guides and any required hardware	63/64	375	375	NA
9	1	Mobile Frame #5 (5 th frame for TL-3 unit / 2 nd frame for TL-2 unit) To include side guides and any required hardware	63/64	375	375	NA
10	1	Mobile Frame #6 (6 th frame for TL-3 unit / 3 rd frame for TL-2 unit) To include side guides and any required hardware	63/64	375	375	NA

Handwritten mark

		To include side guides and any required hardware							
		Front (nose) covers							
11	1	Front cover panel, yellow – TL-2 unit (for mounting reflective panel)	NA	85	85				314100
12	1	Front cover panel, yellow – TL-3 unit (for mounting reflective panel)	NA	85	85				314150
		Front Sleds							
13	1	Front sled – TL-2 unit (to include guide rollers and any additional components / hardware required for installation)	63/64	1710	1710				NA
14	1	Front sled – TL-3 unit (to include guide rollers and any additional components / hardware required for installation)	63/64	1810	1810				NA
		Sheave Tools/Components							
15	1	Anti-rotation pin removal tool	NA	145.8	145.8				NA
16	1	Front sheave anti-rotation pin	NA	55	55				NA
17	1	Rear sheave anti-rotation pin	NA	55	55				NA
18	1	Sheave cover plate (to include attachment hardware)	NA	30.25	30.25				NA
		Transitions							
19	1	Right side jersey barrier transition (to include all required hardware excluding anchor bolts for complete installation)	65/66	1091	1091				NA
20	1	Left side jersey barrier transition (to include all required hardware excluding anchor bolts for complete installation)	65/66	1091	1091				NA
21	1	Right side 24" block transition (to include all required hardware excluding anchor bolts for complete installation)	67/68	702	702				NA
22	1	Left side 24" block transition (to include all required hardware excluding anchor bolts for complete installation)	67/68	702	702				NA
23	1	Right side 30" block straight transition panel (to include all required hardware excluding anchor bolts for complete installation)	69/70	915	915				NA
24	1	Left side 30" block straight transition panel (to include all required hardware excluding anchor bolts for complete installation)	69/70	915	915				NA
25	1	Right side 36" block straight transition panel (to include all required hardware excluding anchor bolts for complete installation)	71/72	1215	1215				NA

DN

26	1	Left side 36" block straight transition panel (to include all required hardware excluding anchor bolts for complete installation)	71/72	1265	1265	1265	NA
27	1	Right side SCI to thrie beam rail transition (to include hardware required for attaching first panel of transition to last SCI side panel)	73/74	1010	1010	1010	NA
28	1	Left side SCI to thrie beam rail transition (to include hardware required for attaching first panel of transition to last SCI side panel)	73/74	1010	1010	1010	NA
29	1	Right side SCI to w-beam rail transition (to include hardware required for attaching first panel of transition to last SCI side panel) To also include intermediary thrie beam transition	75/76	1228	1228	1228	NA
30	1	Left side SCI to w-beam rail transition (to include hardware required for attaching first panel of transition to last SCI side panel) To also include intermediary thrie beam transition	75/76	1228	1228	1228	NA
31	1	Right side straight slope barrier transition (to include all required hardware excluding anchor bolts for complete installation)	77/78	1181	1181	1181	NA
32	1	Left side straight slope barrier transition (to include all required hardware excluding anchor bolts for complete installation)	77/78	1181	1181	1181	NA
Complete Units							
33	1	Work Area Protection SCI Smart Cushion SCI70GM-CA unit, NCHRP-350 Test Level 2, 24" width, to be delivered pre-assembled (to include all anchoring studs and anchoring stud epoxy required for installation on concrete) THIS ITEM MAY ONLY BE ORDERED BY THE TRAFFIC ENGINEERING DIVISION	NA	15000	15000	15000	NA
34	1	Work Area Protection SCI Smart Cushion SCI100GM-CA unit, NCHRP-350 Test Level 3, 24" width, to be delivered pre-assembled (to include all anchoring studs and anchoring stud epoxy required for installation on concrete) THIS ITEM MAY ONLY BE ORDERED BY THE TRAFFIC ENGINEERING DIVISION	NA	15000	15000	15000	NA

EXHIBIT B (NEXT 16 PAGES)

APPENDIX C - SMART CUSHION®, TEST LEVEL 2

- PARTS LIST**
- 01 - Front Sled
 - 02 - Cable Assembly
 - 05 - Sled Panel
 - 07 - Terminal Brace
 - 09 - Anchor Bolts
 - 12 - Side Panels
 - 14 - Mobile Sheave Assembly
 - 17 - Cable Adjuster Bolt
 - 18-20 - Mobile frames 4-6
 - 26 - Cylinder
 - 27 - Rear Panel
 - 06,08,29 - Side Keepers

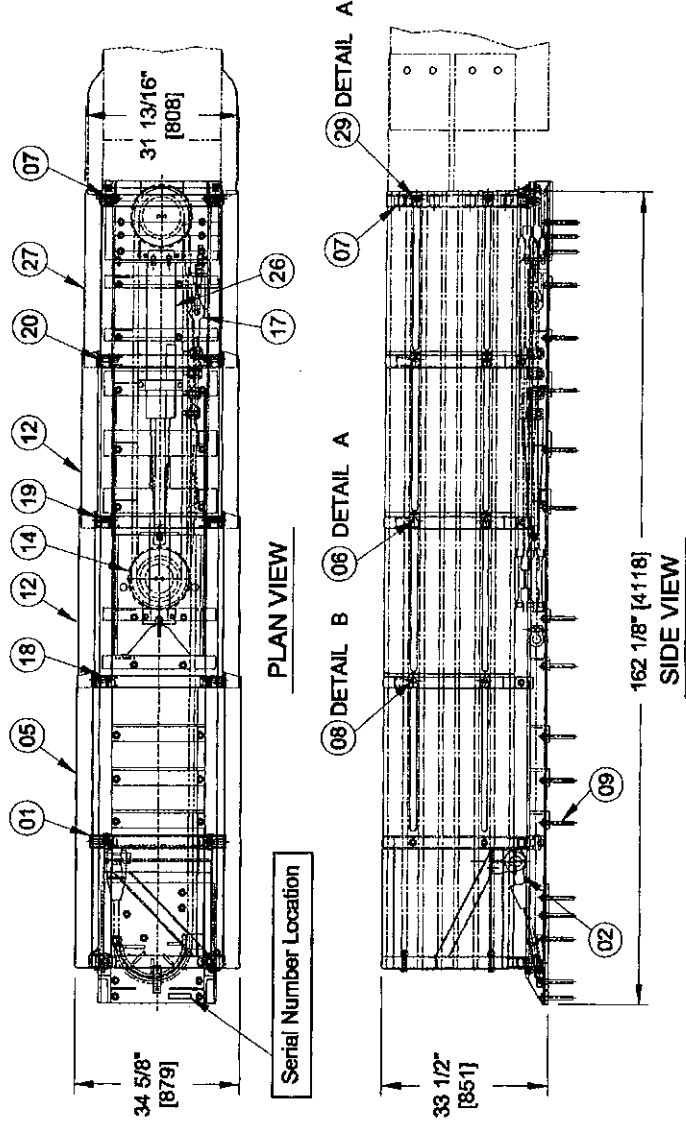
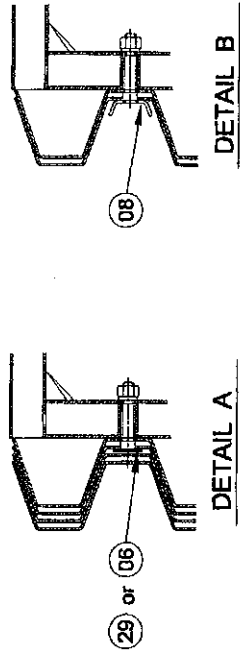

63

APPENDIX D - SMART CUSHION®, TEST LEVEL 3

PARTS LIST	
01 - Front Sled	
02 - Cable Assembly	
05 - Sled Panel	
07 - Terminal Brace	
09 - Anchor Bolts	
12 - Side Panels	
14 - Mobile Sheave Assembly	
17 - Cable Adjuster Bolt	
18-23 - Mobile frames 1-6	
26 - Cylinder	
27 - Rear Panel	
05,08,29 - Side Keepers	

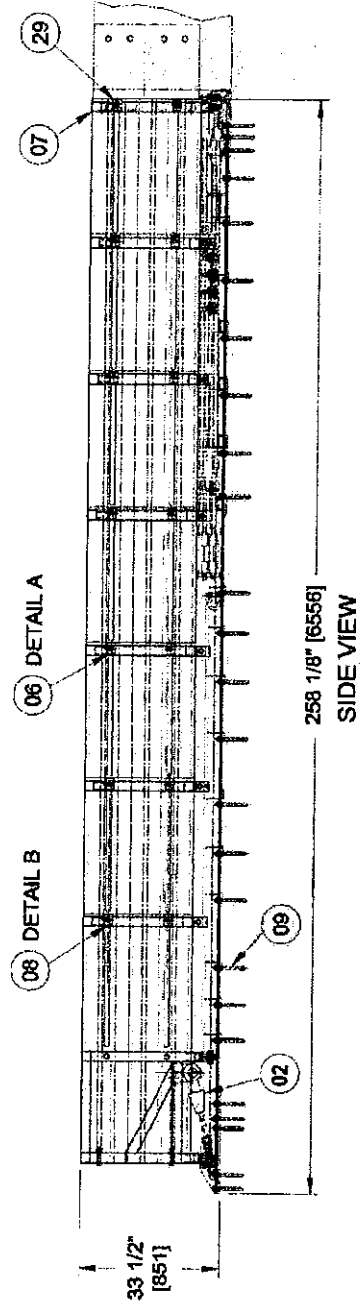
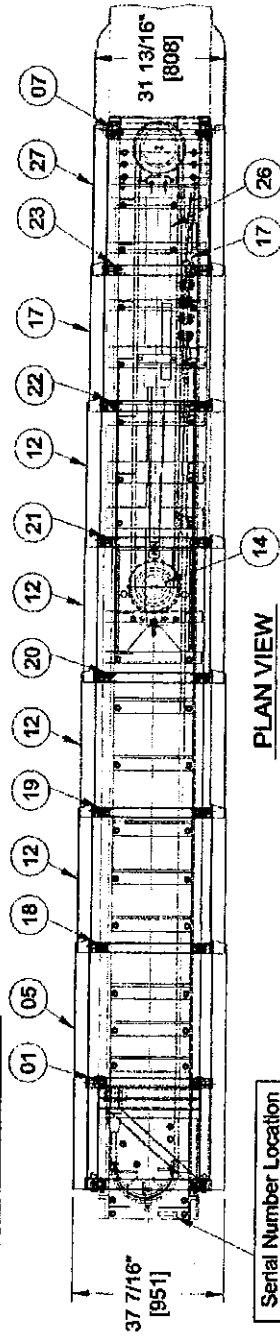
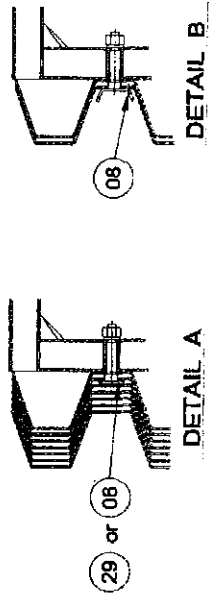

64

APPENDIX G - TRANSITION, JERSEY/F SHAPE BARRIER

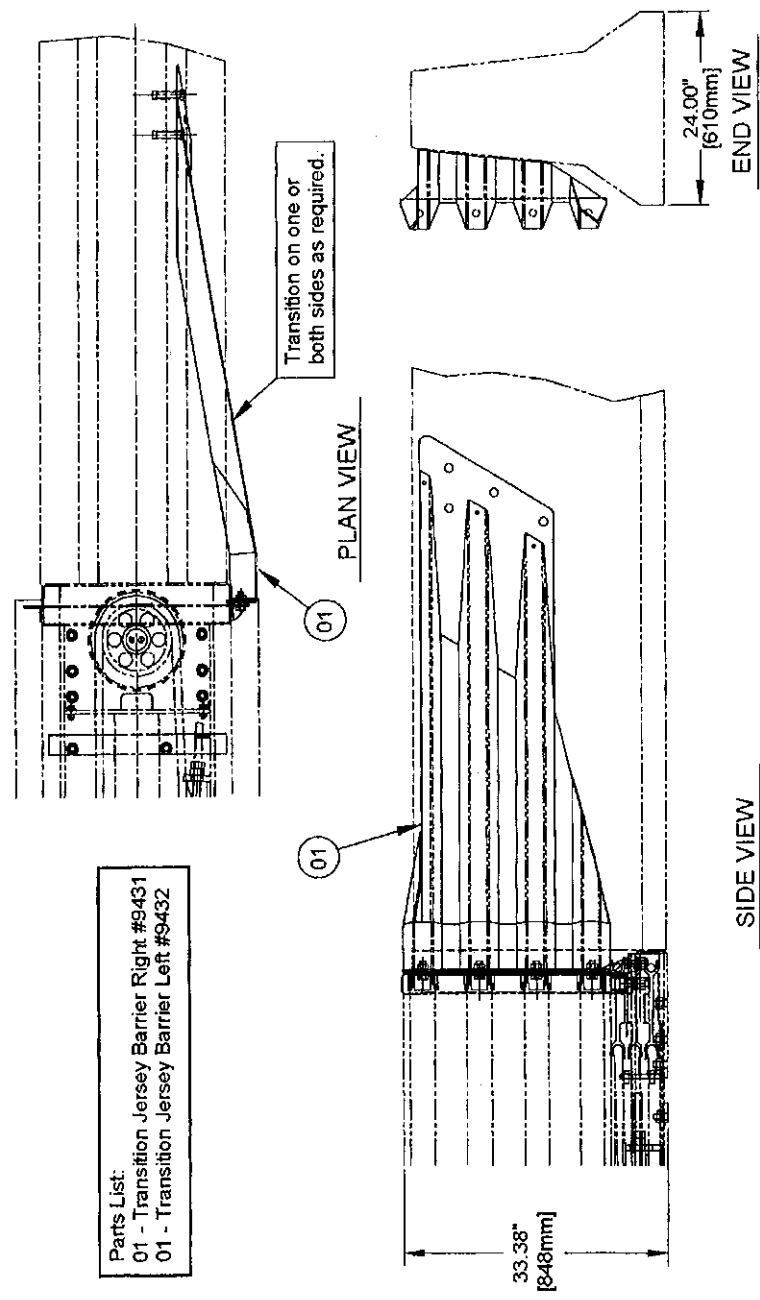

- Parts List:
01 - Transition Jersey Barrier Right #9431
01 - Transition Jersey Barrier Left #9432

65

APPENDIX G(2) - TRANSITION, JERSEY/F SHAPE BARRIER

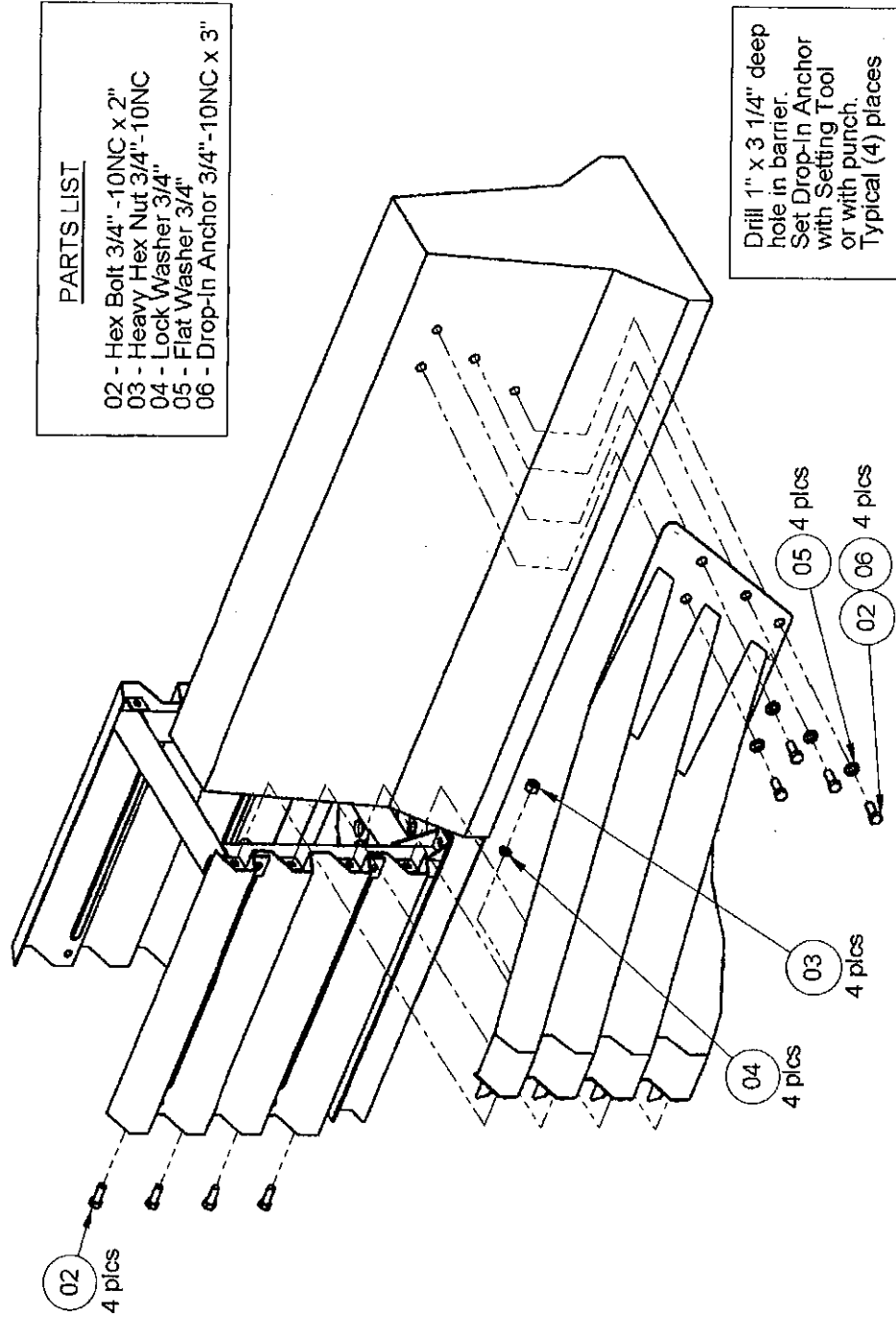

PARTS LIST

- 02 - Hex Bolt 3/4" -10NC x 2"
- 03 - Heavy Hex Nut 3/4" -10NC
- 04 - Lock Washer 3/4"
- 05 - Flat Washer 3/4"
- 06 - Drop-In Anchor 3/4" -10NC x 3"

Drill 1" x 3 1/4" deep hole in barrier. Set Drop-In Anchor with Setting Tool or with punch. Typical (4) places

02 4 pics

04 4 pics

03 4 pics

05 4 pics

06 4 pics

66

APPENDIX H - TRANSITION, CONCRETE BLOCK, 24 INCH (610mm)

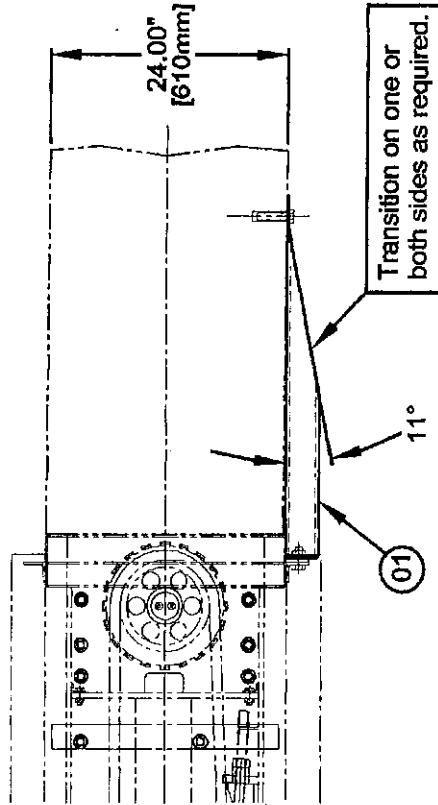

Parts List:
Transition 24" Concrete Block Right & Left #9433

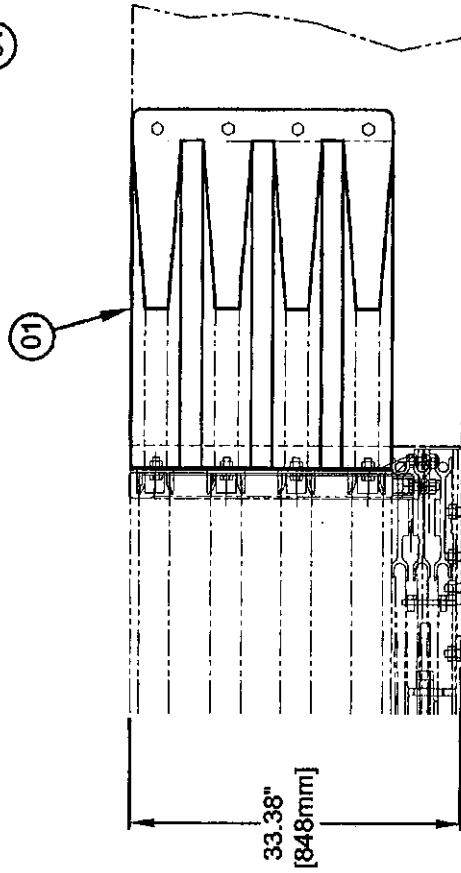

67

APPENDIX H(2) - TRANSITION, CONCRETE BLOCK, 24 INCH (610mm)

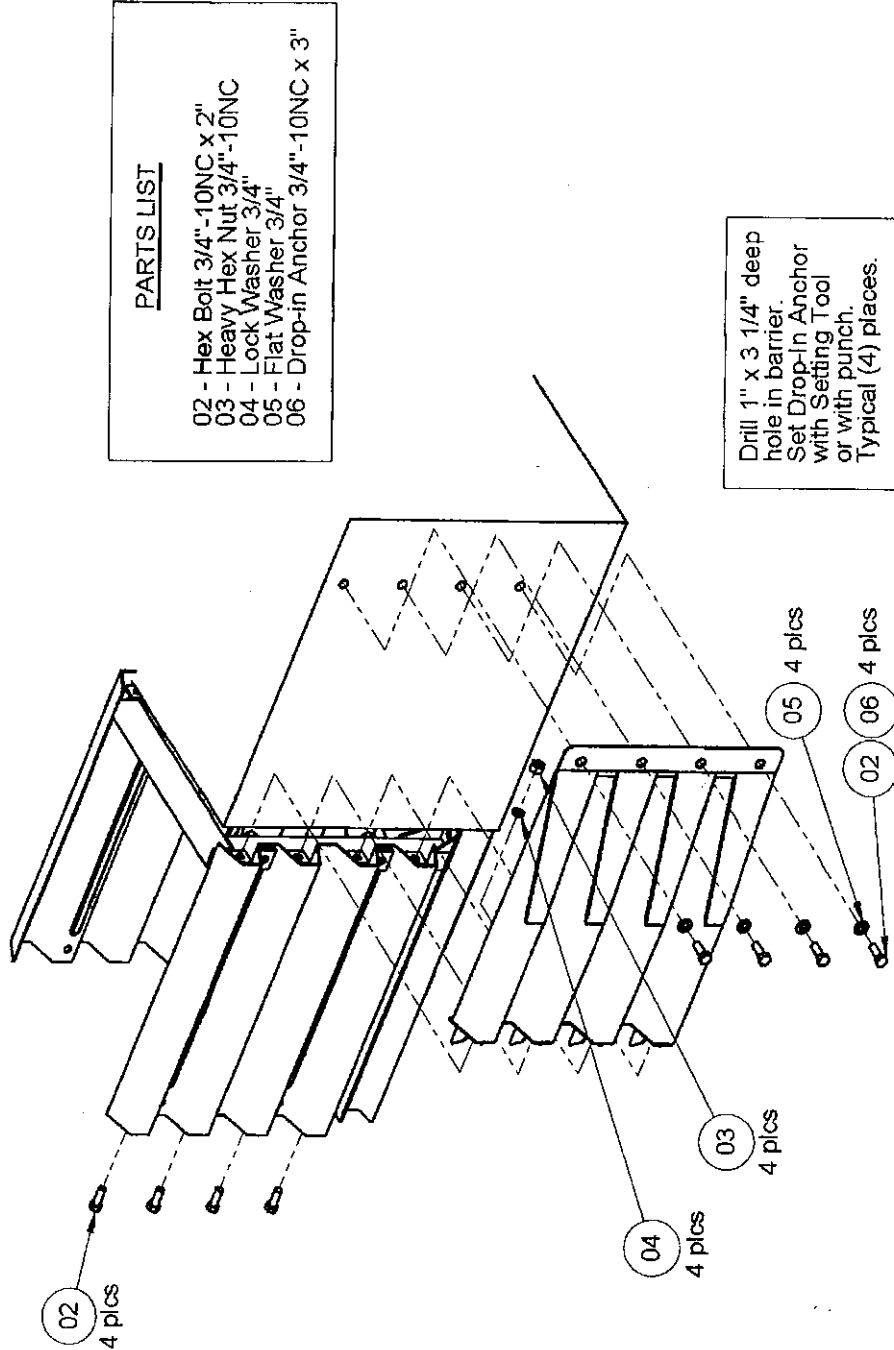

68

APPENDIX I - TRANSITION, CONCRETE BLOCK, 30 INCH (762mm)

Parts List:
 Two Sided Full Assembly #9459
 01-Transition 30" Concrete Straight Connection #9463
 02-Transition Concrete Spanner Brace #9469

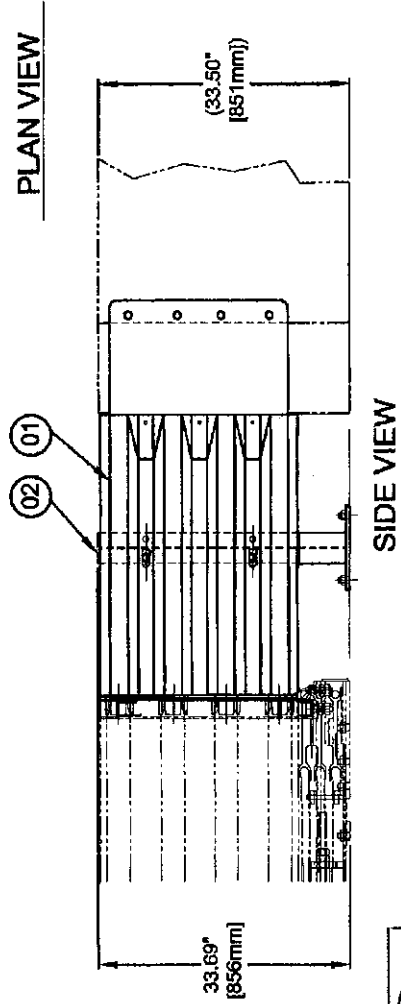
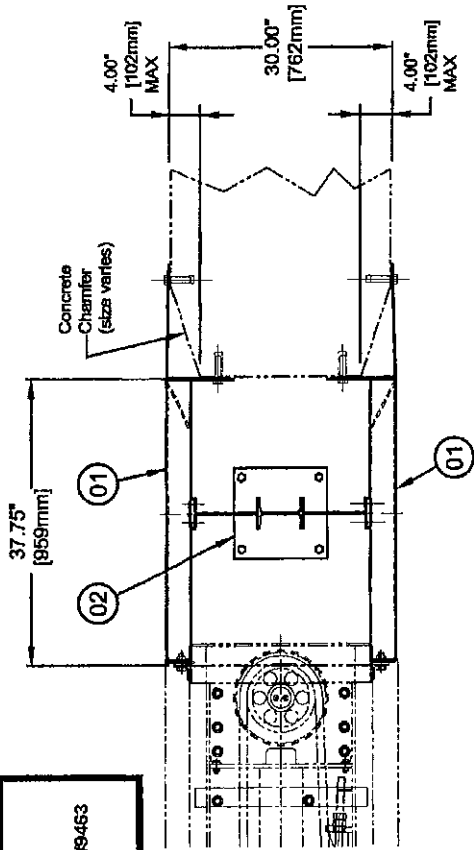

USED FOR:
 1. Unchamfered Concrete Block
 2. Chamfered Concrete Block ***
 *** Chamfer limited to $\le 4^{\circ}$

69

APPENDIX I(2) - TRANSITION, CONCRETE BLOCK, 30 INCH (762mm)

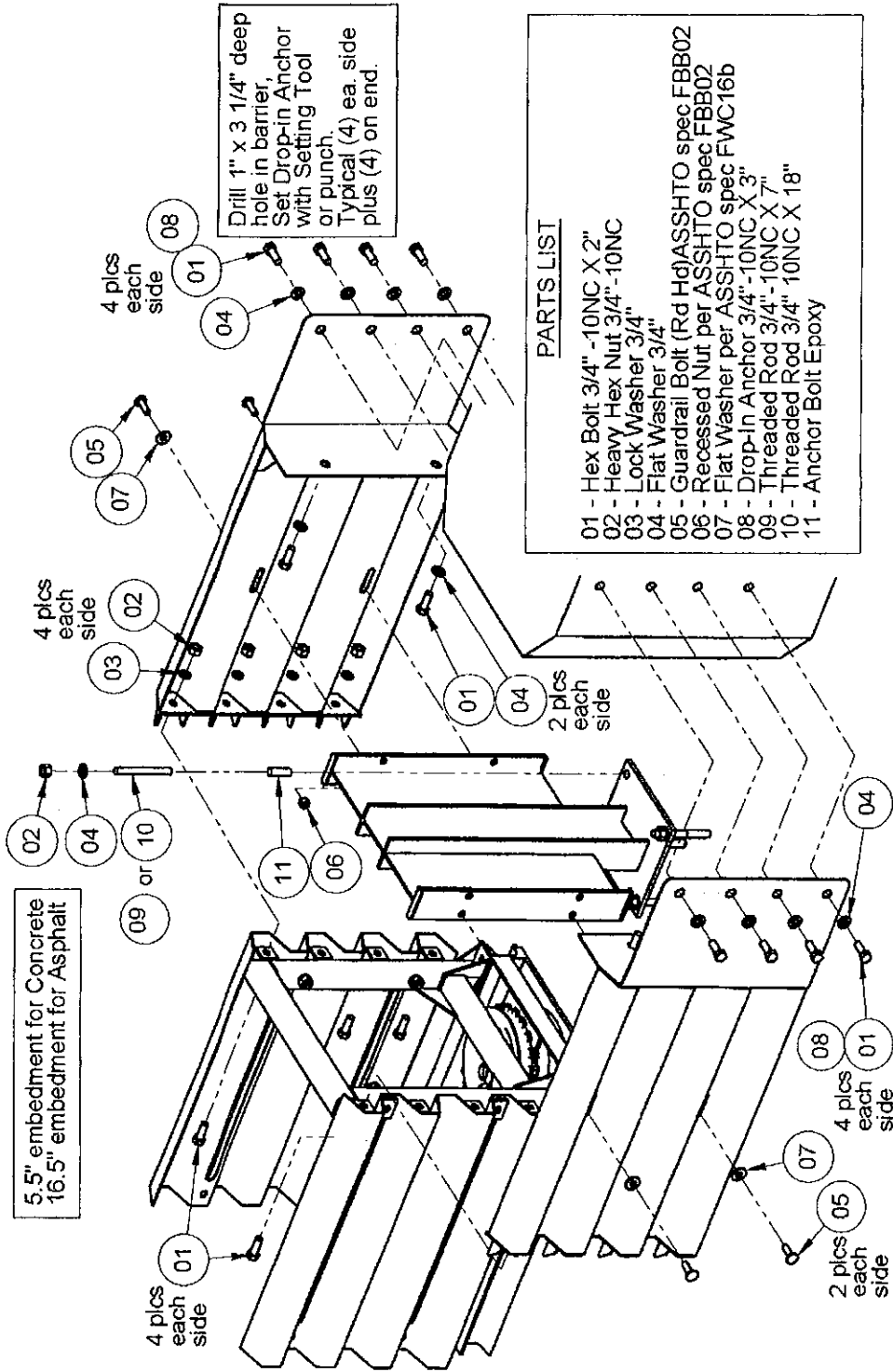

APPENDIX J - TRANSITION, CONCRETE BLOCK, 36 INCH (915mm)

- Parts List:
 Two Sided Full Assembly #8460
 01-Transition 36" Concrete Straight Connection #9464
 02-Transition Concrete Spanner Brace #9469
 03-Transition Concrete #1 Tapered Spanner Brace #9470

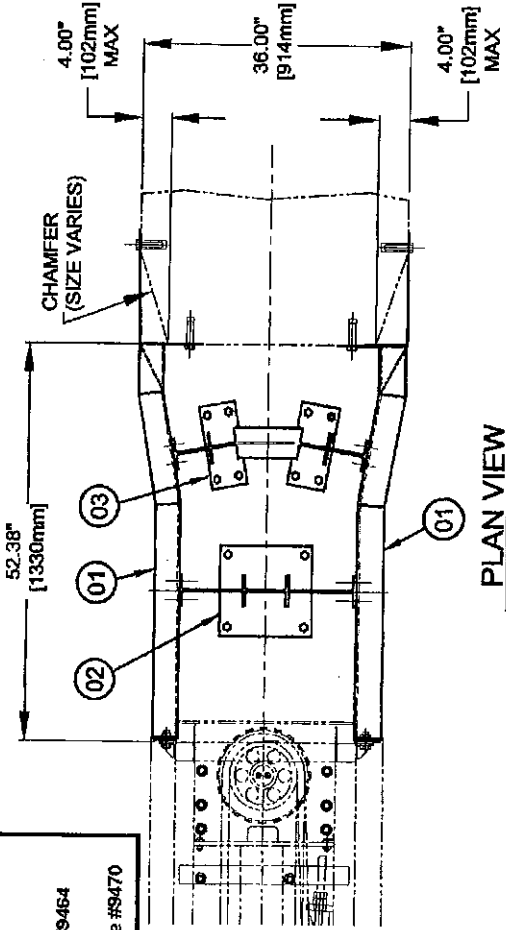

PLAN VIEW

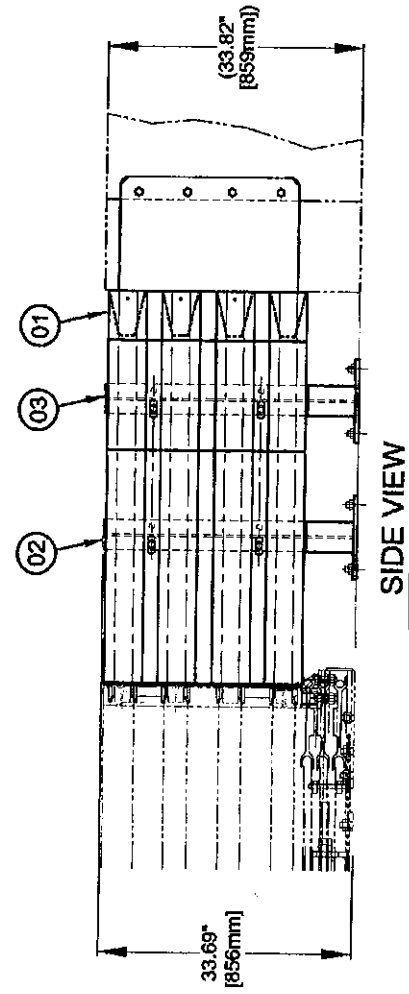

SIDE VIEW

USED FOR:
 1. Unchamfered Concrete Block
 2. Chamfered Concrete Block ***
 *** Chamfer limited to <4"

71

APPENDIX J(2) - TRANSITION, CONCRETE BLOCK, 36 INCH (915mm)

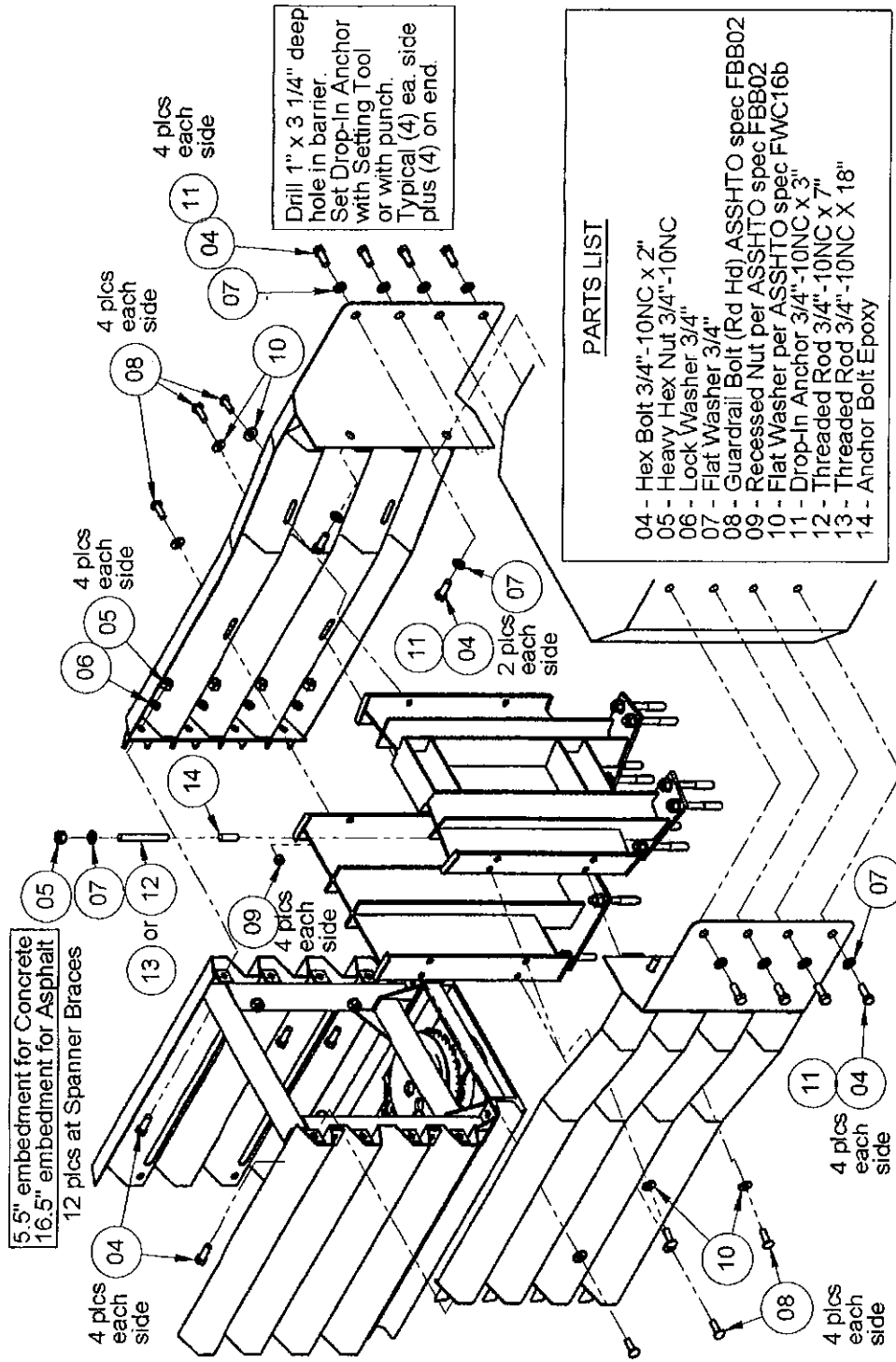

- PARTS LIST**
- 04 - Hex Bolt 3/4"-10NC x 2"
 - 05 - Heavy Hex Nut 3/4"-10NC
 - 06 - Lock Washer 3/4"
 - 07 - Flat Washer 3/4"
 - 08 - Guardrail Bolt (Rd Hd) ASSHTO spec FBB02
 - 09 - Recessed Nut per ASSHTO spec FBB02
 - 10 - Flat Washer per ASSHTO spec FWC16b
 - 11 - Drop-In Anchor 3/4"-10NC x 3"
 - 12 - Threaded Rod 3/4"-10NC x 7"
 - 13 - Threaded Rod 3/4"-10NC x 18"
 - 14 - Anchor Bolt Epoxy

72

APPENDIX M - TRANSITION, THRIE BEAM

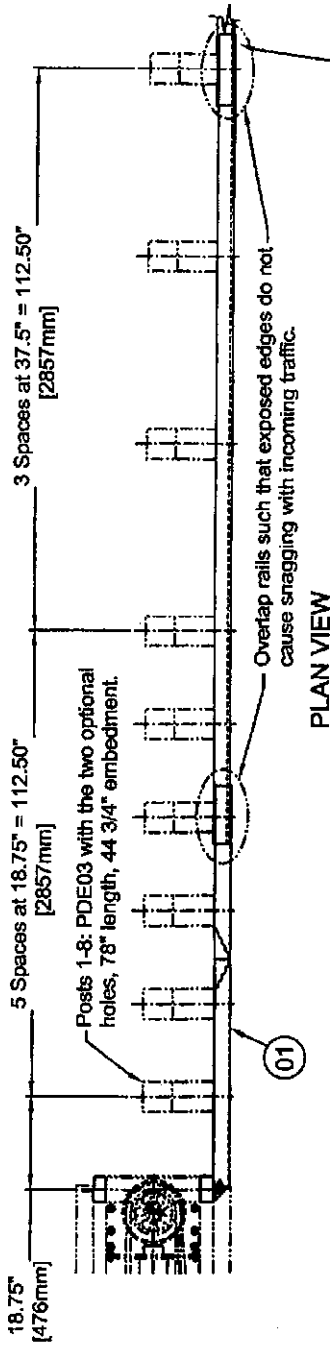

Parts List:
 01 - Transition Thrie & W Beam - Right #9437
 01 - Transition Thrie & W Beam - Left # 9438

*****GUARDRAILS, POSTS, BLOCKOUTS AND CONNECTION BOLTS BY OTHERS.*****

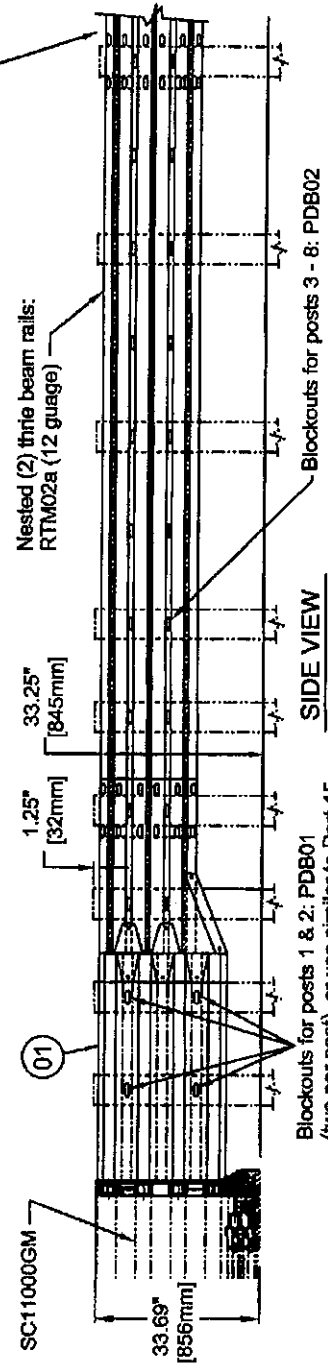

73

APPENDIX M(2) - TRANSITION, THRIE BEAM

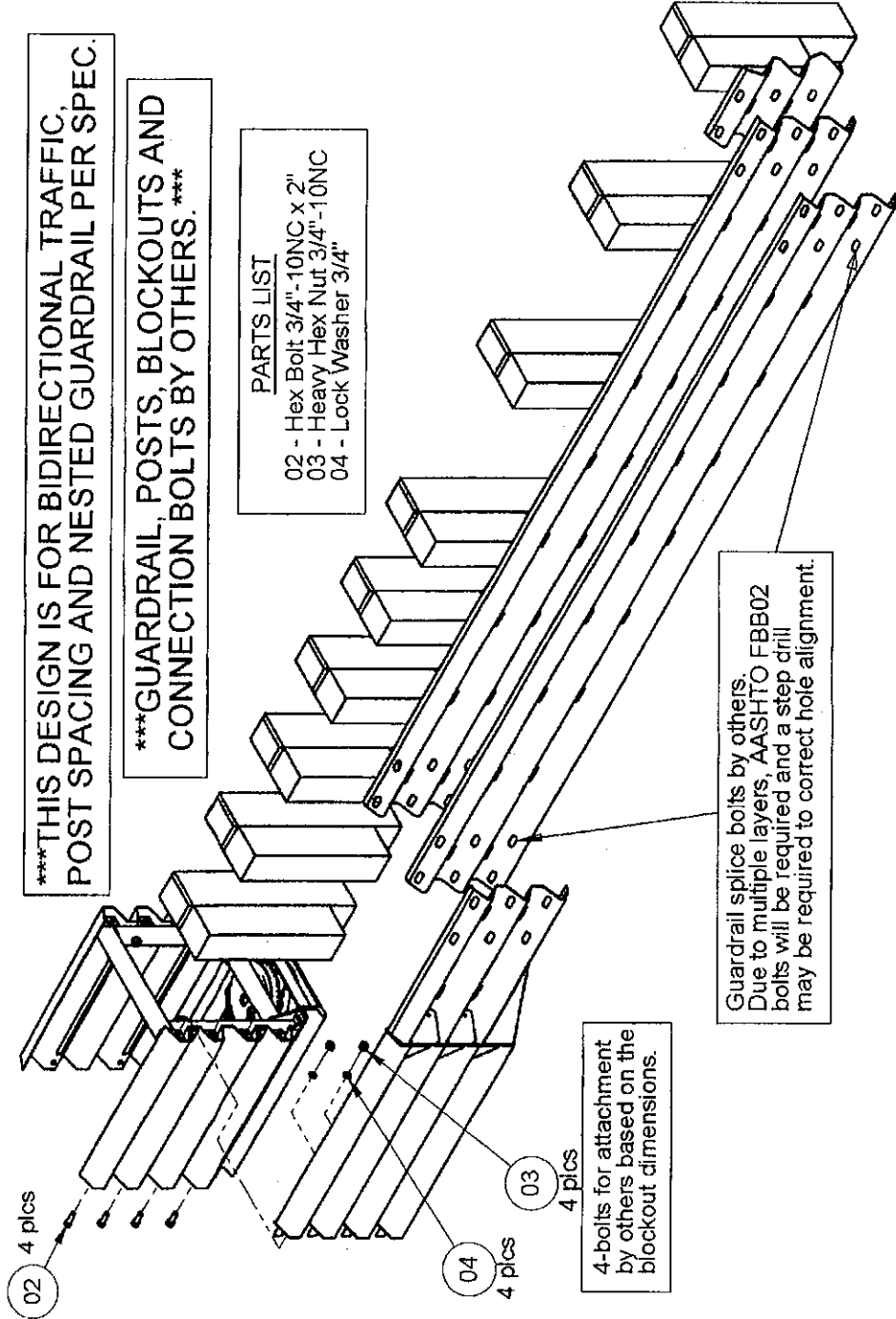

74

APPENDIX N - TRANSITION, W BEAM
*****FOR USE WITH REVERSE DIRECTION TRAFFIC*****

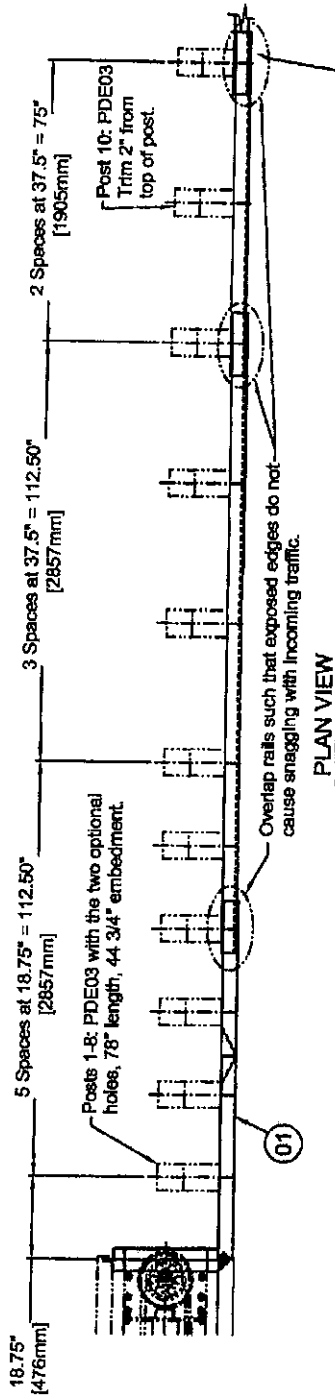

PLAN VIEW

*****GUARDRAIL, POSTS, BLOCKOUTS AND CONNECTION BOLTS BY OTHERS.*****

- Parts List:**
 01 - Transition Thrie & W Beam - Right #9437
 01 - Transition Thrie & W Beam - Left #9438

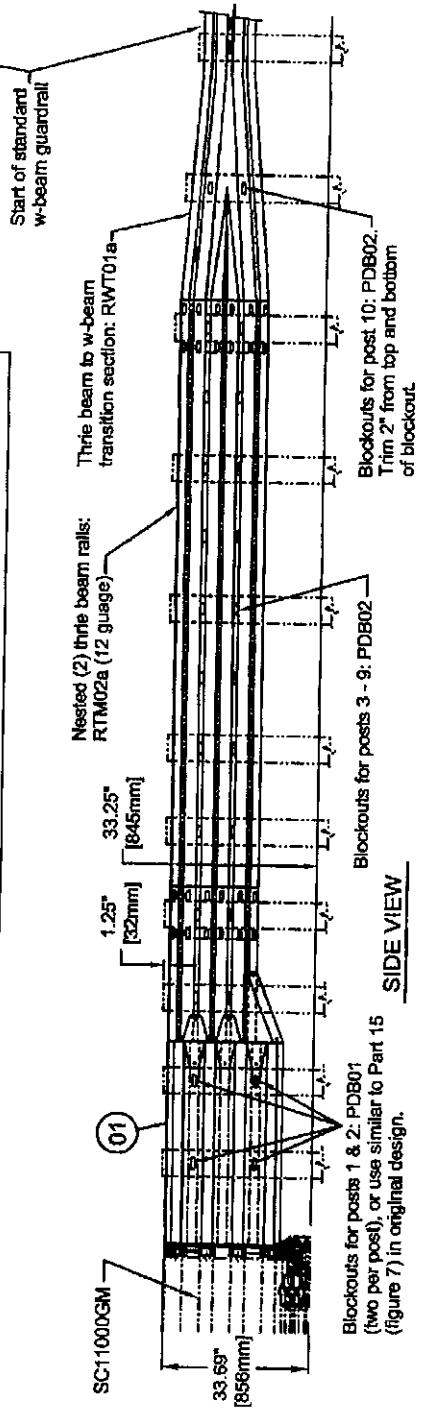

APPENDIX N(2) - TRANSITION, W BEAM

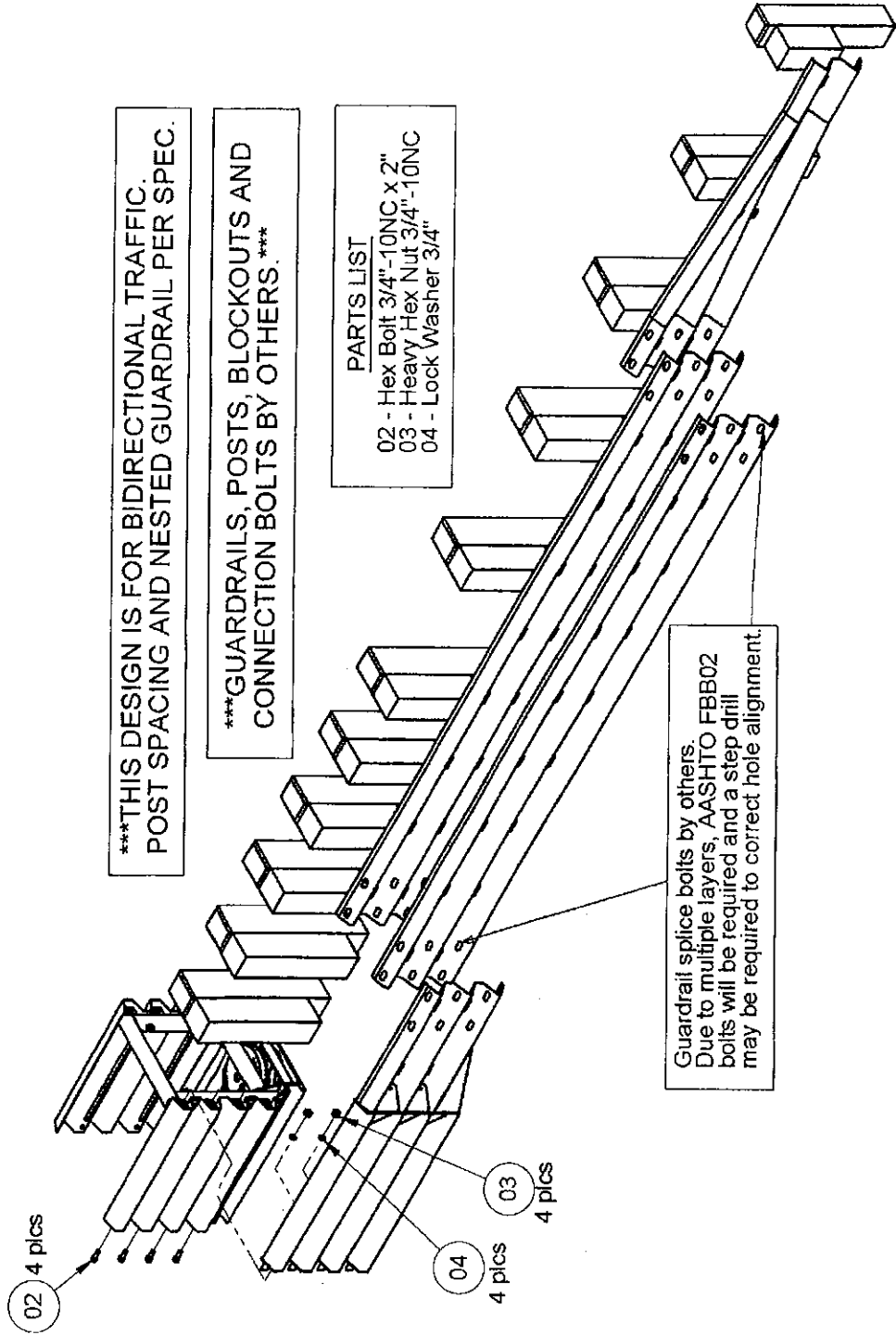

***THIS DESIGN IS FOR BIDIRECTIONAL TRAFFIC.
POST SPACING AND NESTED GUARDRAIL PER SPEC.

***GUARDRAILS, POSTS, BLOCKOUTS AND
CONNECTION BOLTS BY OTHERS.***

- PARTS LIST
- 02 - Hex Bolt 3/4"-10NC x 2"
 - 03 - Heavy Hex Nut 3/4"-10NC
 - 04 - Lock Washer 3/4"

Guardrail splice bolts by others.
Due to multiple layers, AASHTO FBB02
bolts will be required and a step drill
may be required to correct hole alignment.

76

APPENDIX Q - TRANSITION, MEDIAN BARRIER - SINGLE SLOPE

Parts List

- 01 - Transition Single Slope Median Barrier - Right #9490
- 01 - Transition Single Slope Median Barrier - Left #9491

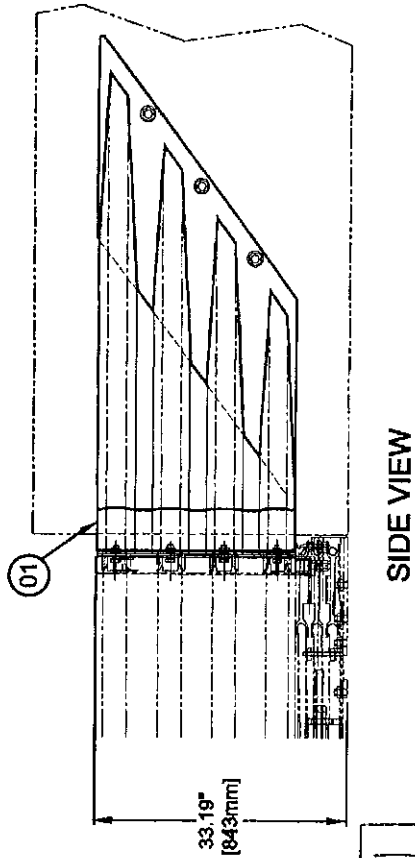
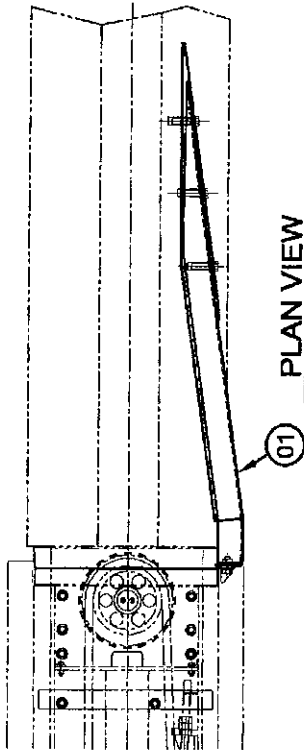

77

APPENDIX Q(2) - TRANSITION, MEDIAN BARRIER - SINGLE SLOPE

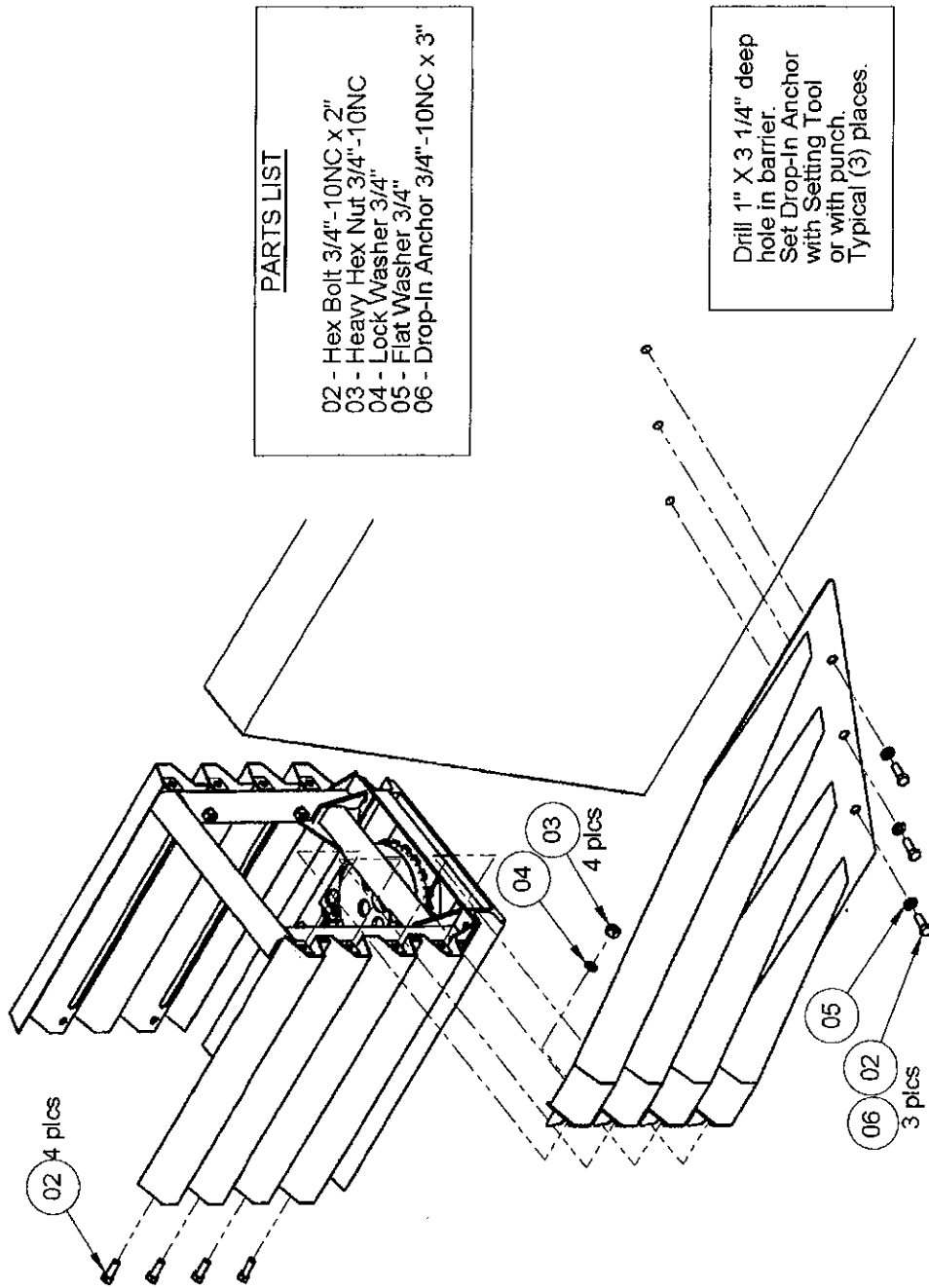

- PARTS LIST**
- 02 - Hex Bolt 3/4"-10NC x 2"
 - 03 - Heavy Hex Nut 3/4"-10NC
 - 04 - Lock Washer 3/4"
 - 05 - Flat Washer 3/4"
 - 06 - Drop-In Anchor 3/4"-10NC x 3"

Drill 1" X 3 1/4" deep hole in barrier. Set Drop-In Anchor with Setting Tool or with punch. Typical (3) places.

78

STATE OF WEST VIRGINIA
Purchasing Division

PURCHASING AFFIDAVIT

MANDATE: Under W. Va. Code §5A-3-10a, no contract or renewal of any contract may be awarded by the state or any of its political subdivisions to any vendor or prospective vendor when the vendor or prospective vendor or a related party to the vendor or prospective vendor is a debtor and: (1) the debt owed is an amount greater than one thousand dollars in the aggregate; or (2) the debtor is in employer default.

EXCEPTION: The prohibition listed above does not apply where a vendor has contested any tax administered pursuant to chapter eleven of the W. Va. Code, workers' compensation premium, permit fee or environmental fee or assessment and the matter has not become final or where the vendor has entered into a payment plan or agreement and the vendor is not in default of any of the provisions of such plan or agreement.

DEFINITIONS:

"Debt" means any assessment, premium, penalty, fine, tax or other amount of money owed to the state or any of its political subdivisions because of a judgment, fine, permit violation, license assessment, defaulted workers' compensation premium, penalty or other assessment presently delinquent or due and required to be paid to the state or any of its political subdivisions, including any interest or additional penalties accrued thereon.

"Employer default" means having an outstanding balance or liability to the old fund or to the uninsured employers' fund or being in policy default, as defined in W. Va. Code § 23-2c-2, failure to maintain mandatory workers' compensation coverage, or failure to fully meet its obligations as a workers' compensation self-insured employer. An employer is not in employer default if it has entered into a repayment agreement with the Insurance Commissioner and remains in compliance with the obligations under the repayment agreement.

"Related party" means a party, whether an individual, corporation, partnership, association, limited liability company or any other form or business association or other entity whatsoever, related to any vendor by blood, marriage, ownership or contract through which the party has a relationship of ownership or other interest with the vendor so that the party will actually or by effect receive or control a portion of the benefit, profit or other consideration from performance of a vendor contract with the party receiving an amount that meets or exceed five percent of the total contract amount.

AFFIRMATION: By signing this form, the vendor's authorized signer affirms and acknowledges under penalty of law for false swearing (W. Va. Code §61-5-3) that neither vendor nor any related party owe a debt as defined above and that neither vendor nor any related party are in employer default as defined above, unless the debt or employer default is permitted under the exception above.

WITNESS THE FOLLOWING SIGNATURE:

Vendor's Name: Protection Services Inc.

Authorized Signature: [Signature] Date: 11/2/15

State of Pennsylvania

County of Cumberland, to-wit:

Taken, subscribed, and sworn to before me this 2 day of November, 2015.

My Commission expires 4/16, 2018.

AFFIX SEAL HERE

NOTARY PUBLIC

[Signature: Gail A. Phillips]

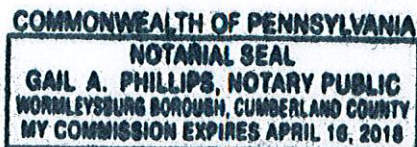

State of West Virginia
VENDOR PREFERENCE CERTIFICATE

Certification and application is hereby made for Preference in accordance with **West Virginia Code, §5A-3-37**. (Does not apply to construction contracts). **West Virginia Code, §5A-3-37**, provides an opportunity for qualifying vendors to request (at the time of bid) preference for their residency status. Such preference is an evaluation method only and will be applied only to the cost bid in accordance with the **West Virginia Code**. This certificate for application is to be used to request such preference. The Purchasing Division will make the determination of the Vendor Preference, if applicable.

1. **Application is made for 2.5% vendor preference for the reason checked:**
 Bidder is an individual resident vendor and has resided continuously in West Virginia for four (4) years immediately preceding the date of this certification; **or,**
 Bidder is a partnership, association or corporation resident vendor and has maintained its headquarters or principal place of business continuously in West Virginia for four (4) years immediately preceding the date of this certification; or 80% of the ownership interest of Bidder is held by another individual, partnership, association or corporation resident vendor who has maintained its headquarters or principal place of business continuously in West Virginia for four (4) years immediately preceding the date of this certification; **or,**
 Bidder is a nonresident vendor which has an affiliate or subsidiary which employs a minimum of one hundred state residents and which has maintained its headquarters or principal place of business within West Virginia continuously for the four (4) years immediately preceding the date of this certification; **or,**
2. **Application is made for 2.5% vendor preference for the reason checked:**
 Bidder is a resident vendor who certifies that, during the life of the contract, on average at least 75% of the employees working on the project being bid are residents of West Virginia who have resided in the state continuously for the two years immediately preceding submission of this bid; **or,**
3. **Application is made for 2.5% vendor preference for the reason checked:**
 Bidder is a nonresident vendor employing a minimum of one hundred state residents or is a nonresident vendor with an affiliate or subsidiary which maintains its headquarters or principal place of business within West Virginia employing a minimum of one hundred state residents who certifies that, during the life of the contract, on average at least 75% of the employees or Bidder's affiliate's or subsidiary's employees are residents of West Virginia who have resided in the state continuously for the two years immediately preceding submission of this bid; **or,**
4. **Application is made for 5% vendor preference for the reason checked:**
 Bidder meets either the requirement of both subdivisions (1) and (2) or subdivision (1) and (3) as stated above; **or,**
5. **Application is made for 3.5% vendor preference who is a veteran for the reason checked:**
 Bidder is an individual resident vendor who is a veteran of the United States armed forces, the reserves or the National Guard and has resided in West Virginia continuously for the four years immediately preceding the date on which the bid is submitted; **or,**
6. **Application is made for 3.5% vendor preference who is a veteran for the reason checked:**
 Bidder is a resident vendor who is a veteran of the United States armed forces, the reserves or the National Guard, if, for purposes of producing or distributing the commodities or completing the project which is the subject of the vendor's bid and continuously over the entire term of the project, on average at least seventy-five percent of the vendor's employees are residents of West Virginia who have resided in the state continuously for the two immediately preceding years.
7. **Application is made for preference as a non-resident small, women- and minority-owned business, in accordance with West Virginia Code §5A-3-59 and West Virginia Code of State Rules.**
 Bidder has been or expects to be approved prior to contract award by the Purchasing Division as a certified small, women- and minority-owned business.

Bidder understands if the Secretary of Revenue determines that a Bidder receiving preference has failed to continue to meet the requirements for such preference, the Secretary may order the Director of Purchasing to: (a) reject the bid; or (b) assess a penalty against such Bidder in an amount not to exceed 5% of the bid amount and that such penalty will be paid to the contracting agency or deducted from any unpaid balance on the contract or purchase order.

By submission of this certificate, Bidder agrees to disclose any reasonably requested information to the Purchasing Division and authorizes the Department of Revenue to disclose to the Director of Purchasing appropriate information verifying that Bidder has paid the required business taxes, provided that such information does not contain the amounts of taxes paid nor any other information deemed by the Tax Commissioner to be confidential.

Under penalty of law for false swearing (West Virginia Code, §61-5-3), Bidder hereby certifies that this certificate is true and accurate in all respects; and that if a contract is issued to Bidder and if anything contained within this certificate changes during the term of the contract, Bidder will notify the Purchasing Division in writing immediately.

Bidder: _____ Signed: _____

Date: _____ Title: _____

...ion Services LLC,
Mumma Rd, Suite 101
Royne, Pa. 17043

RECEIVED
NOV 04 2015
FINANCE DIVISION
DOT
9:00

Finance + Administration
Division of Highways
BLDG 5, RM A-220
1900 Kanawha Blvd E
Charleston, WV. 25302

Phone: 304-558-9398

RECEIVED
15 NOV -4 AM 9:09
FINANCE-PROCUREMENT

FQ 0803 DOT 16 00000007
Area Protection Impact Attenuator Parts
closing date: 2015-11-04 13:30:00